

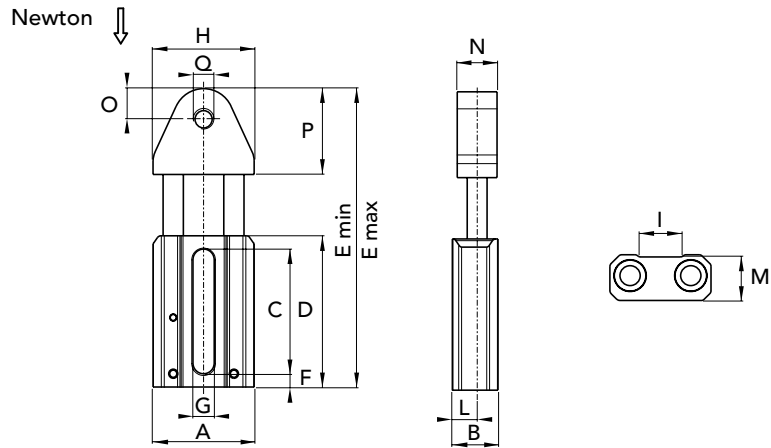

- Tensioner AS with aluminum head to secure accessories
- Dry self-lubricating bushings with standard PTFE
- On request available with stainless steel pin, springs, plugs and washer



TYPE	P. NUMBER	Newton	A	B	C	D	E min	E max	F	G	H	I	L	M	N	O	P	Q	WEIGHT Kg.
AS1 M10	94021010N	240	50	23	61	74	115	143	6,5	10,5	52	20	12,5	22	20	14	40	M10	0,27
AS1 M12	94021012N	240	50	23	61	74	115	143	6,5	10,5	52	20	12,5	22	20	14	40	M12	0,26
AS1 M16	94021016N	240	50	23	61	74	115	143	6,5	10,5	52	20	12,5	22	20	14	40	M16	0,25
AS2 M12	94022012N	420	67	28	73	87	138	175	7	12,5	67	25	15	25,5	25	12	50	M12	0,52
AS2 M16	94022016N	420	67	28	73	87	138	175	7	12,5	67	25	15	25,5	25	12	50	M16	0,51
AS3 M12	94023012N	650	80	32,5	88	104	165	207	8	14,5	80	29,5	17,5	28,5	30	14	60	M12	0,89
AS3 M14	94023014N	650	80	32,5	88	104	165	207	8	14,5	80	29,5	17,5	28,5	30	14	60	M14	0,88
AS3 M16	94023016N	650	80	32,5	88	104	165	207	8	14,5	80	29,5	17,5	28,5	30	14	60	M16	0,88

