

**D 602-603**

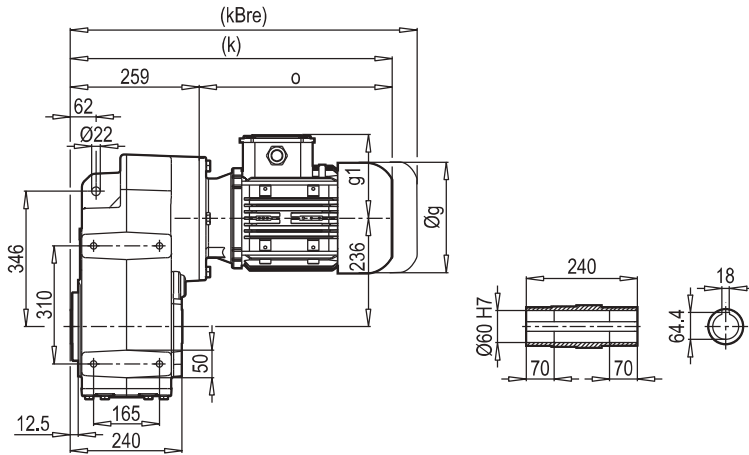

**D 602-603...B14**

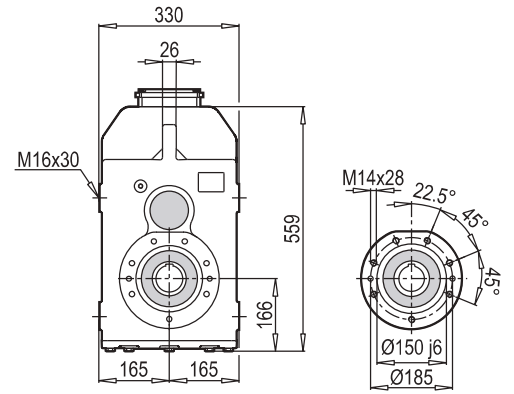

**M 602-603**

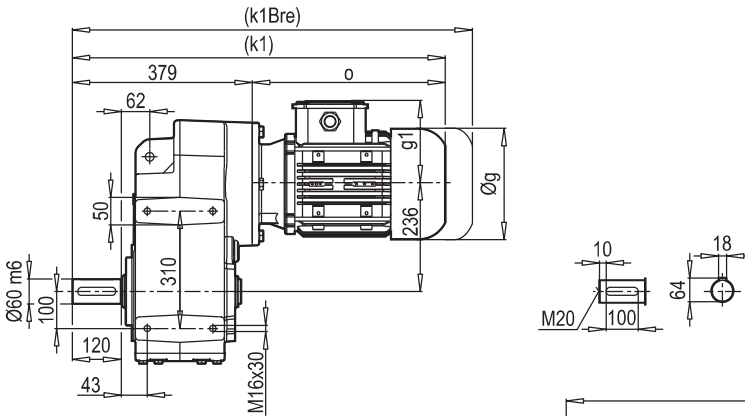

**M 602-603...B14**

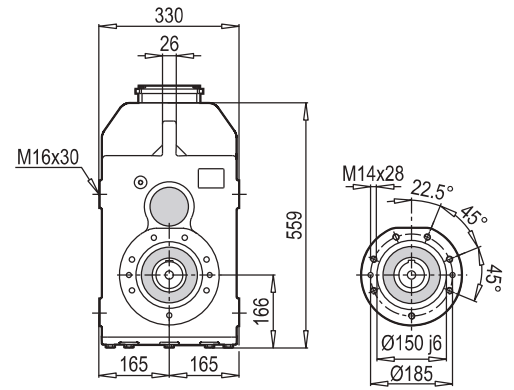

**D/M 602-603...B5**

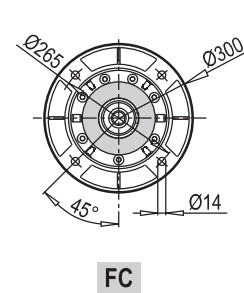
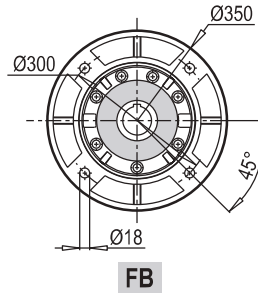
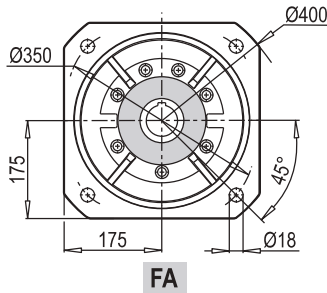
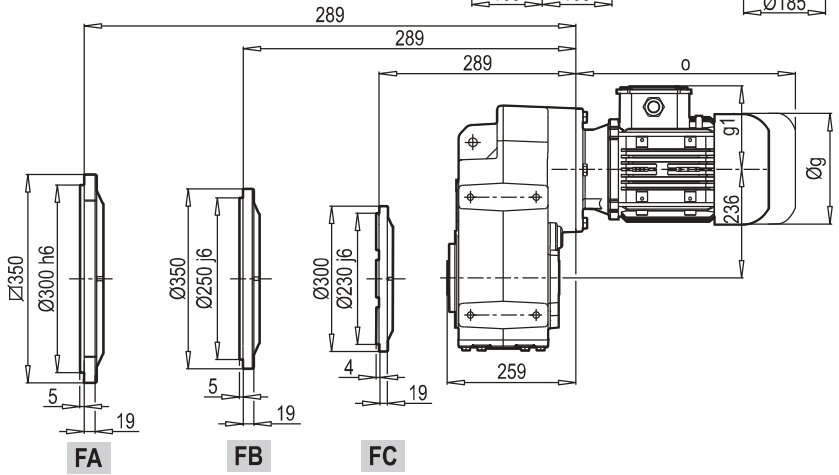
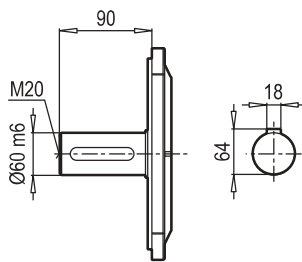

	80M	90S	90L	100L	112M	132S	132M	160M/L	180M/L	200L
<b>g</b>	159	193	193	217	232	279	279	323	370	415
<b>g1</b>	127	151	151	160	168	182	182	200	248	260
<b>k/k1</b>	517/637	542/662	562/682	585/705	639/759	645/765	680/800	767/887	832/952	869/989
<b>kBre/k1Bre</b>	579/699	615/735	635/755	666/786	719/839	753/873	821/941	919/1039	994/1114	1016/1136
<b>o</b>	258	283	303	326	380	386	421	508	573	610

D 602-603 PAM B5/B14

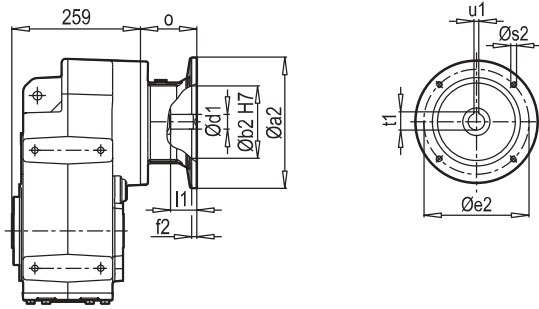

D 602-603 W

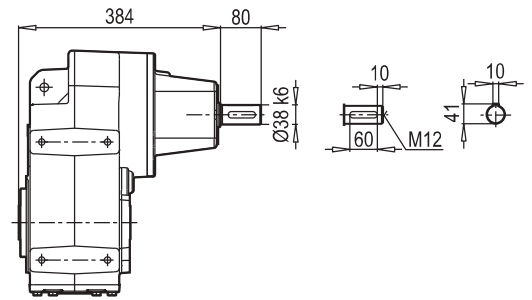

M 602-603 PAM B5/B14

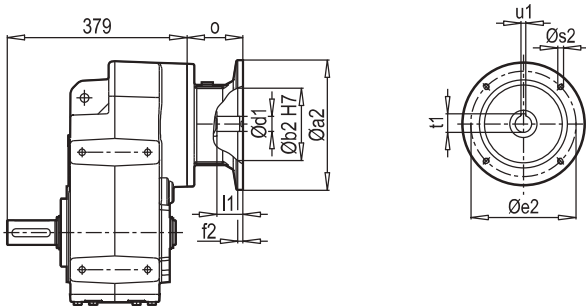

M 602-603 W

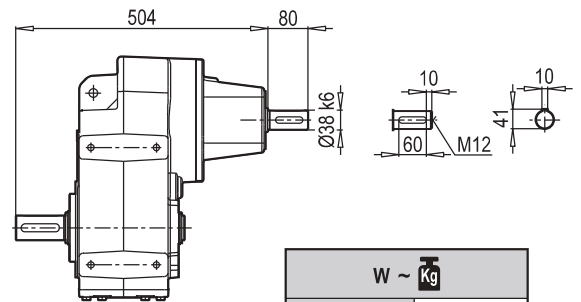

W ~ Kg	
D/M 602 - 603	92

D/M 602-603 B5 PAM B5/B14

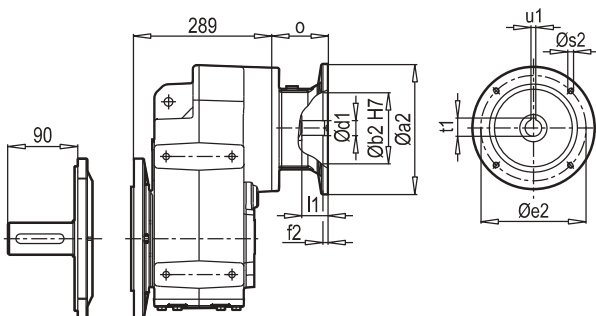

D/M 602-603 B5 W

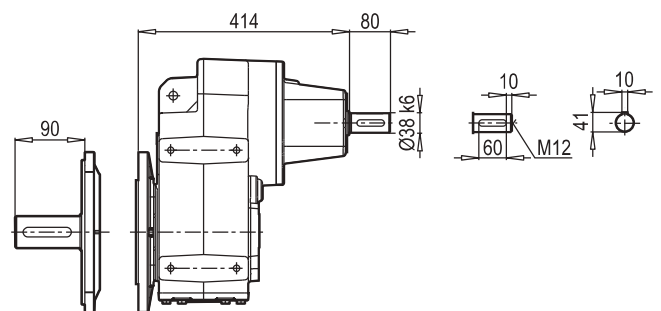

Tip / Type Typ / Tipo Type / Tipo	PAM B5	Øa2	Øb2	Øe2	f2	Øs2	Ød1	l1	t1	u1	o
D/M 602 - 603	80	200	130	165	5	10	19	42	21.8	6	61
	90	200	130	165	5	10	24	52	27.3	8	61
	100	250	180	215	5.5	12	28	62	31.3	8	76
	112	250	180	215	5.5	12	28	62	31.3	8	76
	132	300	230	265	5.5	12	38	82	41.3	10	101
	160	350	250	300	7	16	42	112	45.3	12	148
	180	350	250	300	7	16	48	112	51.8	14	148
	200	400	300	350	7	16	55	112	59.3	16	185

~ Kg		
PAM B5/B14	D/M 602	D/M 603
80	83	83
90	83	83
100	87	87
112	87	87
132	90	90
160	96	-
180	96	-
200	112	-

Tip / Type Typ / Tipo Type / Tipo	PAM B14	Øa2	Øb2	Øe2	f2	Øs2	Ød1	l1	t1	u1	o
D/M 602 - 603	80	120	80	100	3	7	19	42	21.8	6	61
	90	140	95	115	3	9	24	52	27.3	8	61
	100	160	110	130	3.5	9	28	62	31.3	8	76
	112	160	110	130	3.5	9	28	62	31.3	8	76
	132	200	130	165	3.5	11	38	82	41.3	10	101

Type Typ / Tipo / Type / Tipo	iges	4-pol 50Hz 1400rpm n2 [min-1]	Mamax f <sub>B</sub> =1 4 - pol. [Nm]	P <sub>1max</sub> W f <sub>B</sub> ≥ 1				PAM - IEC									
				4 - pol. 1400rpm [kW]	FR1 [kN]	FR2GR [kN]	FR2 [kN]										
<b>D 603</b> <b>M 603</b>	343.64	4.1	3000	1.36	3.9	30.0	11.2	80	90	100	112						
	300.83	4.7	3000	1.56	3.9	30.0	11.2	80	90	100	112						
	279.86	5.0	3000	1.67	3.9	30.0	11.2	80	90	100	112						
	238.56	5.9	3000	1.96	3.9	30.0	11.2	80	90	100	112	132					
	194.28	7.2	3000	2.41	3.9	30.0	11.2	80	90	100	112	132					
	177.25	7.9	3000	2.64	3.9	30.0	11.2	80	90	100	112	132					
	150.99	9.3	3000	3.10	3.9	30.0	11.2	80	90	100	112	132					
	133.43	10.5	3000	3.51	3.8	30.0	11.2	80	90	100	112	132					
	122.97	11.4	3000	3.80	3.8	30.0	11.2	80	90	100	112	132					
	112.19	12.5	3000	4.17	3.8	30.0	11.2	80	90	100	112	132					
	86.78	16.1	3000	5.39	3.8	30.0	11.2			100	112	132					
	70.67	19.8	2700	5.96	3.7	30.0	11.2			100	112	132					
	<b>D 602</b> <b>M 602</b>	66.88	20.9	3000	6.80	3.7	30.0	11.0	80	90	100	112	132				
54.47		25.7	2600	7.24	3.7	30.0	10.5	80	90	100	112	132					
49.69		28.2	2400	7.32	3.7	30.0	10.3	80	90	100	112	132					
44.19		31.7	3000	10.30	3.6	30.0	9.1	80	90	100	112	132					
41.65		33.6	3000	10.94	3.5	30.0	8.9			100	112	132	160	180			
35.72		39.2	3000	12.75	3.5	29.1	8.3			100	112	132	160	180			
33.92		41.3	3000	13.43	3.5	28.4	8.1			100	112	132	160	180			
30.95		45.2	3000	14.71	3.4	27.2	7.8			100	112	132	160	180			
29.04		48.2	3000	15.70	3.4	26.4	7.5			100	112	132	160	180			
26.54		52.8	3000	17.17	3.3	25.3	7.2			100	112	132	160	180			
23.65		59.2	2900	18.63	3.3	24.3	6.9			100	112	132	160	180			
21.58		64.9	2800	19.72	3.2	23.6	6.7			100	112	132	160	180			
17.30		80.9	2600	22.89	3.1	21.9	6.3						160	180	200		
14.09		99.4	2400	25.95	3.0	20.6	5.9						160	180	200		
12.85		108.9	2200	26.08	3.0	20.5	5.9						160	180	200		
11.65		120.1	1900	24.90	3.0	20.7	5.9						160	180	200		
9.49		147.5	1700	27.36	2.9	19.6	5.6						160	180	200		
8.66	161.7	1500	26.46	3.0	19.6	5.6						160	180	200			