

STANDARD OPEN TRANSMISSION COMPONENTS



IMPORTANT:

Our Company is able to produce pieces, on request, based on Customer's drawings in the required quantity and quality. Our Company uses modern machine tools that also allows to produce pitches and profiles not shown in this catalogue.

CHIARAVALLI GROUP SpA, do not accepts responsibility for any errors in the production of this catalogue and reserves the right to add to the drawings designs of the listed products any modification request by manufacturing requirements or due to evolution of the products.

CHIARAVALLI GROUP SpA assures that the Company's quality system complies with the provisions established in the italian UNI EN ISO 9001 - 2008, regulations governing quality management criteria which guarantees the quality of the products manufactured.

ICIM

CERTIFICATO n. **1236/6**
 CERTIFICATE No. **1236/6**

SI CERTIFICA CHE IL SISTEMA DI GESTIONE PER LA QUALITÀ DI
 WE HEREBY CERTIFY THAT THE QUALITY MANAGEMENT SYSTEM OPERATED BY

CHIARAVALLI GROUP S.P.A.
 Sede e Unità Operativa
 Via per Cedrate, 476 - 21044 Cavarina con Premazzo (VA) - Italia
 Amministrazione, Commerciale, Acquisti, Magazzino centrale e logistica.
 Unità Operativa
 Via della Concordia, 33 - 21040 Menzago di Sumirago (VA) - Italia
 Cromatura lame affettatrici.
 Via Dante, 40 - 21040 Jerago con Orago (VA) - Italia
 Magazzino e logistica lame per affettatrici.
 LMC S.r.l.
 Via Tito Minelli, 560 - 21044 Cavarina con Premazzo (VA) - Italia
 Direzione, Commerciale OEM, progettazione, lavorazioni meccaniche,
 Via P. Resconi, 5 - 21040 Oggiona Santo Stefano (VA) - Italia
 Lavorazioni meccaniche, produzione lame per affettatrici.

È CONFORME ALLA NORMA / IS IN COMPLIANCE WITH THE STANDARD
UNI EN ISO 9001:2015

Sistema di Gestione per la Qualità / Quality Management System
 PER LE SEGUENTI ATTIVITÀ / FOR THE FOLLOWING ACTIVITIES

EA: 17 - 29

Commercializzazione, progettazione e produzione di organi di trasmissione meccanica di potenza: pignoni, corone, pulegge, ruote dentate, coppie coniche, calettori e cremagliere.
 Commercializzazione di catene e cinghie. Produzione di lame per affettatrici.
 Trading, design and production of power transmission components : platwheels, pulleys, spingears, sprockets, bevel gears, shaft clamping elements, racks, Trading of chain and belt.
 Production of slicing machine blades.

Allegato alla documentazione del Sistema di Gestione per la Qualità secondo le disposizioni della norma di riferimento.
 Refer to the documentation of the Quality Management System for details of application to reference standard requirements.
 Il presente certificato è soggetto al rispetto del documento ICIM "Requisiti per la certificazione dei sistemi di gestione" e al relativo Schema specifico.
 The use and the validity of this certificate shall satisfy the requirements of the ICIM document "Rules for the certification of company management systems" and specific Scheme.
 Per informazioni puntuali e aggiornate circa eventuali variazioni intervenute nello stato della certificazione di cui al presente certificato,
 in caso di variazioni di indirizzo ISO 9001:2015 visitate il sito internet:
 For timely and updated information about any changes in the certification status referred to in this certificate,
 please contact the number +39 02 725941 or email address info@icim.it

Data emissione First issue 20/05/1999	Emissione corrente Current issue 14/09/2018	Data di scadenza Expiring date 13/09/2021
---	---	---

ICIM S.P.A.
 Piazza Don Enrico Mattei, 75 - 20099 Sesto San Giovanni (MI)
 www.icim.it

FEDERAZIONE CISQ
 www.cisq.com

MEMBER OF ACCREDITED BY UNIFORMIL

MEMBERSHIP OF EA, JAF AND ILAC MUTUAL RECOGNITION AGREEMENTS

CISQ è la Federazione Italiana di Organismi di Certificazione del sistema di gestione aziendale.
 CISQ is the Italian Federation of management system Certification bodies.

IQNet
 THE INTERNATIONAL CERTIFICATION NETWORK

CERTIFICATE

CISQ/ICIM SPA has issued an IQNet recognized certificate that the organization:

CHIARAVALLI GROUP S.P.A.
 Head Office and Operative Unit
 Via per Cedrate, 476 - I-21044 Cavarina con Premazzo (VA)
 Operative Units
 LMC S.r.l., Via Tito Minelli, 560 - I-21044 Cavarina con Premazzo (VA)
 Via P. Resconi, 5 - I-21040 Oggiona Santo Stefano (VA)
 Via della Concordia, 33 - I-21040 Menzago di Sumirago (VA)
 Via Dante, 40 - I-21040 Jerago con Orago (VA)
 has implemented and maintains a
Quality Management System
 for the following scope:
Trading, design and production of power transmission components : platwheels, pulleys, spingears, sprockets, bevel gears, shaft clamping elements, racks, Trading of chain and belt.
Production of slicing machine blades.
 which fulfils the requirements of the following standard:
ISO 9001:2015

Issued on:	2018-09-14
First issued on:	1999-05-20
Expires on:	2021-09-13

This attestation is directly linked to the IQNet Partner's original certificate and shall not be used as a stand-alone document.

Registration Number: **IT-7734**

IQNet Alex Stoichitoin President of IQNET

CISQ Ing. Claudio Provetti President of CISQ

IQNet Partners:
 AENOR Spain AFNOR Certification France APCER Portugal CCC Cipros CISQ Akyi
 CDC China COM China COS Casca & Republica Cio Cert Canada DQS Holding GmbH Germany FCAV Brazil
 FONDROMORA, Romania KONTEC Colombia Inspeco Sertificatori Oy Finland INTECO Costa Rica
 IRAM Argentina IQA Aguar KIQ Korea IIRTEC Greece MSZT Hungary Nemko AS Norway NSAI Ireland
 NYCE-SIGE Mexico PCB-C Poland Quality Austria dmanu RR, Russia SHI Israel SIO Slovenia
 SIRIM QAS International Malaysia SGS Switzerland SIALC Romania TEST SA Petersburg Russia TSE Turkey VUOS Serbia
 IQNet is represented in the USA by: AFNOR Certification, CISQ, DQS Holding GmbH and NSAI Inc.

* The list of IQNet partners is valid at the time of issue of this certificate. Updated information is available under www.iqnet-certification.com

Sprockets and Idler Sprockets



Platewheels, Wheels for table top chains, Hubs and adaptors



Chains and Polyethylene Chain guide rail



Straight spur gears and racks



Bevel gears



Timing pulleys



V-belt pulleys



Timing bars, Flanges for pulleys, Clamping belts plates



Taper bushes BrandRCB®



Clamping elements RCK® Brand



Flexible couplings GIFLEX® Brand, Torque limiters



Collars and washers



Pillow blocks FSB® Brand, Monoblock pillow blocks RCM® Brand



Adjustable motor mounting





CHIARAVALLI GROUP world:
much more than a collection of perfect mechanical components



SPROCKETS

ISO CHAIN SPROCKETS	page 4
ASA CHAIN SPROCKETS	21
STAINLESS STEEL CHAIN SPROCKETS	28
SIMPLEX CHAIN SPROCKETS HARDENED	30
SIMPLEX CHAIN SPROCKETS WITH HARDENED TEETH WITH HOLE + KEYWAY + SCREW HOLES	32
TAPER LOCK[®] CHAIN SPROCKETS	42
CHAIN SPROCKETS IN CAST IRON	46
CHAIN SPROCKETS FOR CONVEYORS AND ELEVATORS	50
IDLER SPROCKETS	52



CHAIN SPROCKETS FOR ROLLER CHAINS

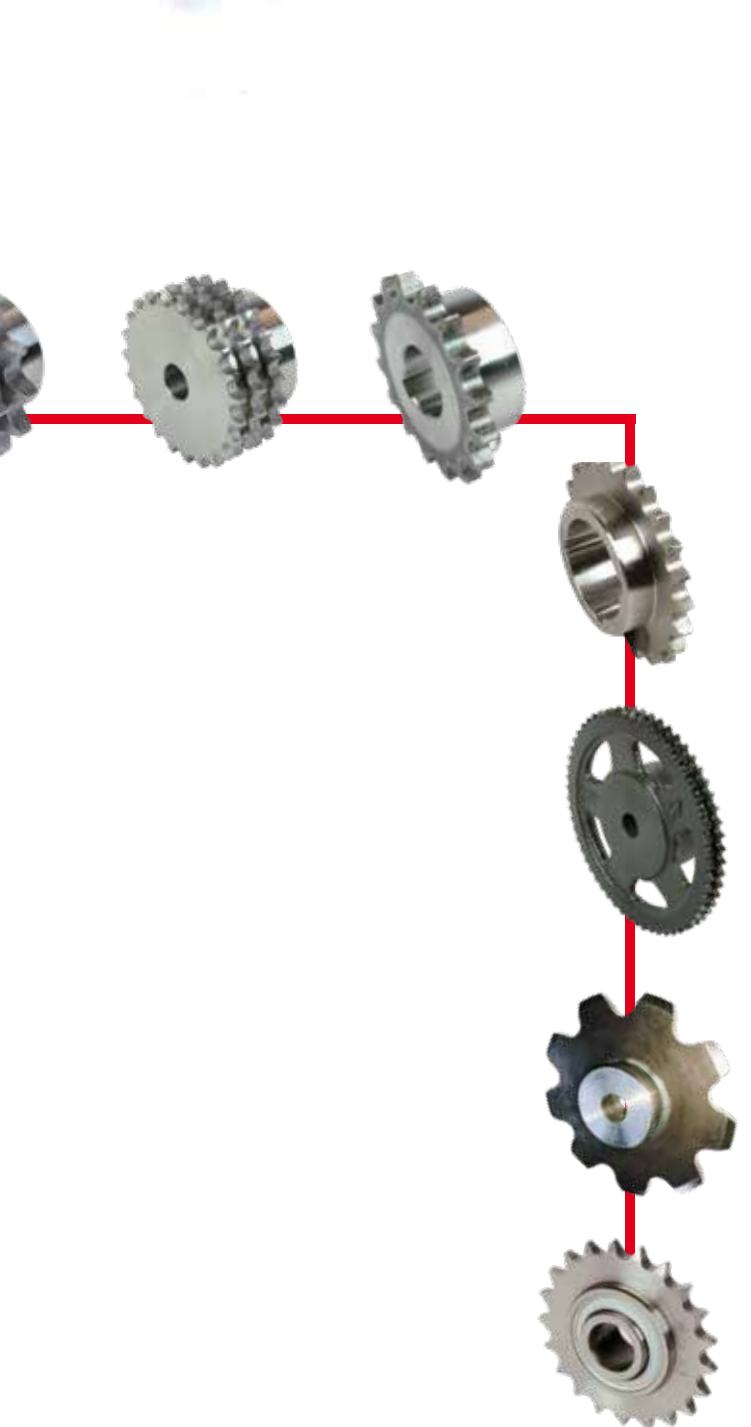
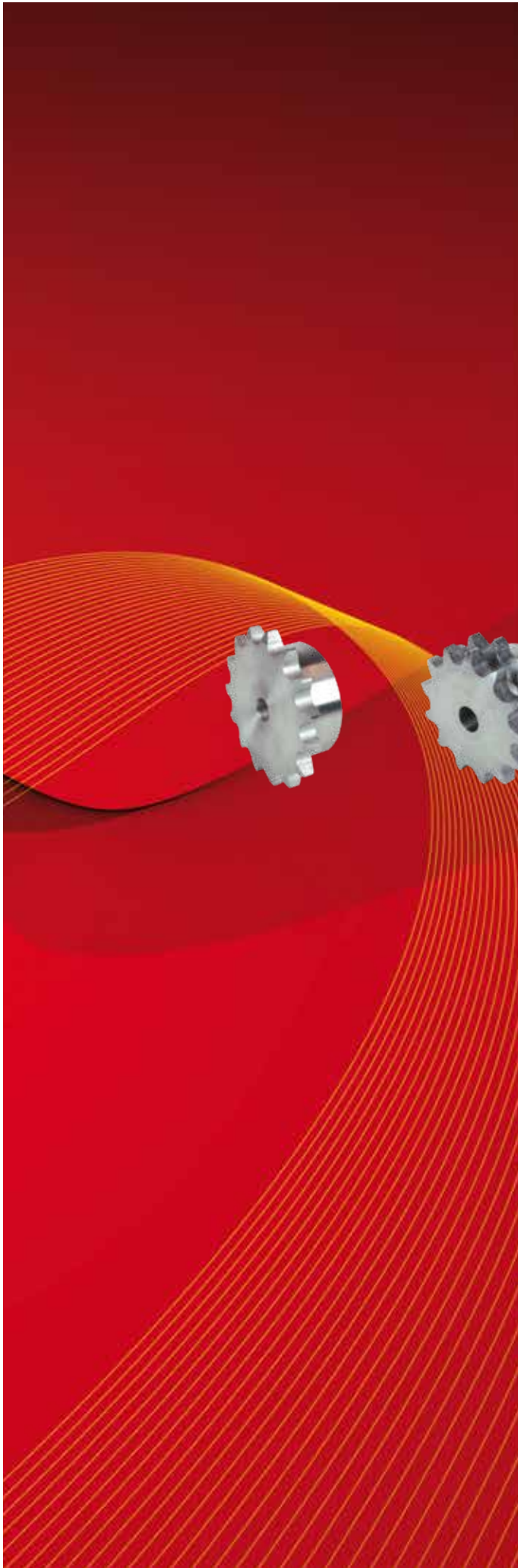



The range of sprockets designed for chains manufactured by our Company provides an all-round solution to the needs of industry in the sector of flexible mechanical transmissions and is the result of a manufacturing process that is designed to achieve the top in terms of technical and quality performance.

Our production programme includes sprockets and wheels designed for chains, produced in compliance with the principles and with the most recent Standards and International Unified Standards: UNI, ISO, DIN, ANSI, etc.

However, the standards define a profile with minimum dimensions and a profile with maximum dimensions for the wheel space for chains and rollers and the actual profile must lie within these values.

There is the option of selecting proportioning criteria for the profile, since the tolerances that the Standards leave to the manufacturer's discretion are quite wide. The profiles can be optimised in terms of smooth transmission and the tooth's capacity to support greater stresses. This has led to the systematic development of a series of standardised profiles for which the geometry can be reproduced with great precision by tools designed specifically by computer and the reference profile of which is protected by the Company's knowhow.

A valued feature of this optimised profile, which is a characteristic exclusive to CHIARAVALLI GROUP SpA, is that of enhancing the "polygonal" chain wrap-around on the sprocket and on the platewheel, reproducing the motion discontinuity which is achieved even in the case of unfavourable transmission ratios and centre distances.

As a result of this CHIARAVALLI GROUP SpA has been able to include sprockets with a very low number of teeth in its catalogue and production programme.

Respecting precision with limited machining errors is beneficial, even if the toothed wheel-chain set represents a somewhat "basic" transmission solution.

This precision is assured by the systematic use of CNC machines and technologies developed to minimise the shearing stress and to improve the degree of surface finish.

The sprockets and wheels designed for chains included in the catalogue are also manufactured in the version with the "Taperlock" taper bush piece system particularly favoured in applications that require easy assembly and very precise centring tolerances.

Our sales programme is completed with single and multiple roller chains, and special chains suitable for every industrial application and CHIARAVALLI GROUP SpA is also able to manufacture sprockets and platewheels suitable for chains in a specific execution, produced to drawing any of material and with induction hardening and case-hardening and hardening applied to steel wheels and sprockets.

5 x 2.5 mm
CHAIN SPROCKETS

Tooth radius r_3	5	mm
Radius width \bar{C}	0,6	mm
Sprockets tooth width B_1	2,3	mm

CHAIN

Pitch	5	mm
Inner width	2,5	mm
Roller \varnothing	3,2	mm

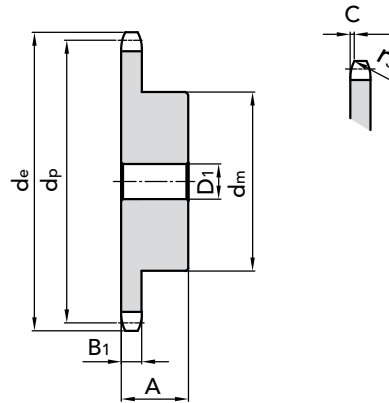
SIMPLEX

Z	d _e	d _p	PART NUMBER	d _m	D ₁	A	kg.
8	15,20	13,06	10105008	7	4	10	0,01
9	16,80	14,62	10105009	8	4	10	0,01
10	18,30	16,18	10105010	9	4	10	0,01
11	19,90	17,75	10105011	11	5	10	0,01
12	21,50	19,32	10105012	12	5	10	0,01
13	23,00	20,89	10105013	14	5	10	0,01
14	24,60	22,47	10105014	15	5	10	0,02
15	26,20	24,04	10105015	16	5	10	0,02
16	27,80	25,63	10105016	18	6	13	0,02
17	29,40	27,20	10105017	18	6	13	0,03
18	30,90	28,79	10105018	18	6	13	0,03
19	32,50	30,38	10105019	18	6	13	0,03
20	34,10	31,96	10105020	18	6	13	0,03
21	35,70	33,54	10105021	20	8	13	0,04
22	37,30	35,13	10105022	20	8	13	0,04
23	38,90	36,72	10105023	20	8	13	0,04
24	40,50	38,30	10105024	20	8	13	0,04
25	42,00	39,89	10105025	20	8	13	0,04
26	43,60	41,48	10105026	25	8	15	0,05
27	45,20	43,07	10105027	25	8	15	0,07
28	46,80	44,65	10105028	25	8	15	0,07
29	48,40	46,25	10105029	25	8	15	0,07
30	50,00	47,83	10105030	25	8	15	0,07
31	51,60	49,42	10105031	30	8	15	0,10
32	53,20	51,01	10105032	30	8	15	0,10
33	54,80	52,60	10105033	30	8	15	0,10
34	56,30	54,19	10105034	30	8	15	0,10
35	57,90	55,78	10105035	30	8	15	0,11
36	59,50	57,37	10105036	30	8	15	0,11
37	61,10	58,96	10105037	30	8	15	0,11
38	62,70	60,54	10105038	30	8	15	0,11
39	64,30	62,13	10105039	30	8	15	0,12
40	65,90	63,73	10105040	30	8	15	0,12

 MATERIAL **C 45 UNI 7845**

 CAD drawings available on our site
www.chiaravalli.com

 Quantity, availability and prices
 on B2B Chiaravalli





6 x 2.8 mm

CHAIN SPROCKETS

Tooth radius r_3	6	mm
Radius width \bar{C}	0,7	mm
Sprockets tooth width B_1	2,6	mm

CHAIN

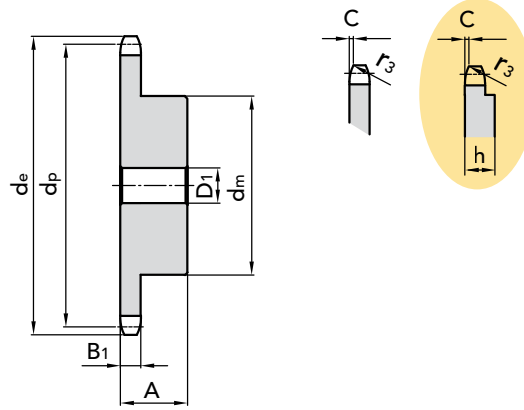
Pitch	6	mm
Inner width	2,8	mm
Roller \varnothing	4	mm



SIMPLEX

Z	d_e	d_p	PART NUMBER	d_m	D_1	A	kg.
8	18,00	15,67	10106008	9,8	5	10	0,01
9	19,90	17,54	10106009	11,5	5	10	0,01
10	21,70	19,42	10106010	13	6	10	0,01
11	23,60	21,30	10106011	14	6	10	0,01
12	25,40	23,18	10106012	16	6	10	0,02
13	27,30	25,05	10106013	18	8	10	0,02
14	29,20	26,96	10106014	20	8	10	0,03
15	31,00	28,86	10106015	20	8	10	0,03
16	33,00	30,76	10106016	20	8	13	0,03
17	35,00	32,65	10106017	20	8	13	0,04
18	36,90	34,55	10106018	20	8	13	0,04
19	38,80	36,44	10106019	20	8	13	0,04
20	40,70	38,34	10106020	20	8	13	0,04
21	42,60	40,25	10106021	25	8	13	0,06
22	44,50	42,16	10106022	25	8	13	0,06
23	46,40	44,06	10106023	25	8	13	0,06
24	48,30	45,96	10106024	25	8	13	0,07
25	50,20	47,87	10106025	25	8	13	0,07
26	52,10	49,76	10106026	30	8	15	0,10
27	54,00	51,67	10106027	30	8	15	0,10
28	55,90	53,58	10106028	30	8	15	0,11
29	57,80	55,50	10106029	30	8	15	0,11
30	59,80	57,42	10106030	30	8	15	0,11
31	61,70	59,31	10106031	30	8	15	0,11
32	63,60	61,21	10106032	30	8	15	0,12
33	65,50	63,11	10106033	30	8	15	0,12
34	67,40	65,02	10106034	30	8	15	0,12
35	69,30	66,93	10106035	30	8	15	0,13
36	71,20	68,84	10106036	30	8	15	0,13
37	73,10	70,75	10106037	30	8	15	0,14
38	75,00	72,66	10106038	30	8	15	0,14
39	76,90	74,57	10106039	30	8	15	0,14
40	78,90	76,47	10106040	30	8	15	0,15
45	88,50	86,01	10106045	40	10	16	0,46
48	94,20	91,74	10106048	62	12	18	0,48
50	98,00	95,55	10106050	50	12	20	0,49
57	111,40	108,93	10106057	50	12	20	0,53
76	147,60	145,19	10106076	60	12	20	1,58

MATERIAL C 45 UNI 7845

From Z 57 to Z 76 the width disk wheel is increased to $h = 4\text{mm}$

CAD drawings available on our site
www.chiaravalli.com

Quantity, availability and prices
 on B2B Chiaravalli





1/4" x 1/8"

CHAIN SPROCKETS

Tooth radius r_3	6,4	mm
Radius width \check{C}	0,7	mm
Sprockets tooth width B_{1a}	2,9	mm

CHAIN

Pitch	6,35	mm
Inner width	3,18	mm
Roller \varnothing	3,3	mm

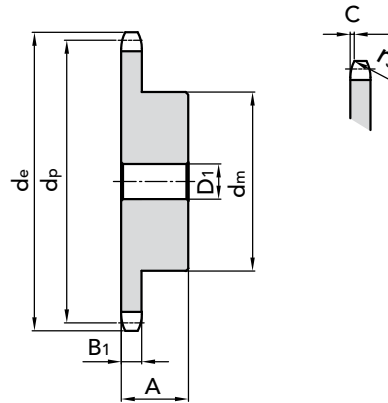

SIMPLEX

Z	d _e	d _p	PART NUMBER	d _m	D ₁	A	kg.
8	19,40	16,58	10107008	10	6	12	0,01
9	21,40	18,56	10107009	11,5	6	12	0,01
10	23,30	20,55	10107010	13	6	12	0,02
11	25,30	22,54	10107011	15	8	13	0,02
12	27,30	24,53	10107012	17	8	13	0,02
13	29,30	26,53	10107013	17	8	13	0,03
14	31,30	28,53	10107014	17	8	13	0,03
15	33,30	30,53	10107015	20	8	13	0,04
16	35,30	32,55	10107016	22	8	14	0,05
17	37,30	34,55	10107017	22	8	14	0,05
18	39,40	36,56	10107018	25	8	14	0,06
19	41,40	38,58	10107019	25	8	14	0,06
20	43,40	40,58	10107020	25	8	14	0,06
21	45,40	42,60	10107021	30	8	14	0,08
22	47,40	44,62	10107022	30	8	14	0,09
23	49,40	46,63	10107023	30	8	14	0,09
24	51,40	48,64	10107024	30	8	14	0,09
25	53,50	50,66	10107025	30	8	14	0,10
26	55,50	52,67	10107026	30	8	16	0,11
27	57,50	54,69	10107027	30	8	16	0,12
28	59,50	56,71	10107028	30	8	16	0,12
29	61,50	58,73	10107029	30	8	16	0,12
30	63,60	60,75	10107030	30	8	16	0,13
31	65,60	62,76	10107031	30	8	16	0,13
32	67,60	64,78	10107032	30	8	16	0,13
33	69,60	66,80	10107033	30	8	16	0,14
34	71,60	68,82	10107034	30	8	16	0,17
35	73,60	70,84	10107035	30	8	16	0,17
36	75,60	72,85	10107036	30	8	16	0,15
37	77,70	74,87	10107037	30	8	16	0,18
38	79,70	76,89	10107038	30	8	16	0,16
39	81,70	78,91	10107039	30	8	16	0,19
40	83,70	80,93	10107040	30	8	16	0,17

MATERIAL C 45 UNI 7845

CAD drawings available on our site
www.chiaravalli.com

Quantity, availability and prices
 on B2B Chiaravalli





8 x 3 mm

CHAIN SPROCKETS

Tooth radius r_3	8	mm
Radius width \bar{C}	1,0	mm
Sprockets tooth width B_1	2,8	mm
Sprockets tooth width b_1	2,7	mm
Sprockets tooth width B_2	8,3	mm

CHAIN

Pitch	8	mm
Inner width	3	mm
Roller \varnothing	5	mm

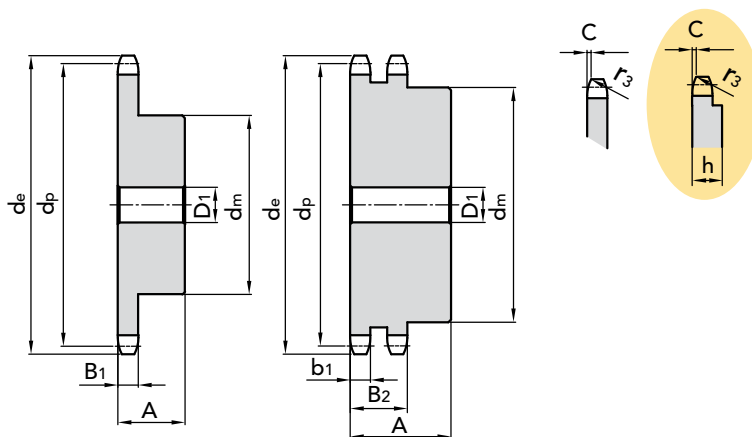

SIMPLEX

DUPLEX

Z	d_e	d_p	PART NUMBER	d_m	D_1	A	kg.	PART NUMBER	d_m	D_1	A	kg.
8	24,00	20,90	10108008	13	6	12	0,01	10208008	12	8	18	0,02
9	26,60	23,39	10108009	15	6	12	0,02	10208009	15	8	18	0,03
10	29,20	25,89	10108010	17	8	12	0,02	10208010	17	8	18	0,03
11	31,70	28,39	10108011	18	8	13	0,03	10208011	19	10	18	0,04
12	34,20	30,91	10108012	20	8	13	0,04	10208012	21	10	18	0,05
13	36,70	33,42	10108013	23	8	13	0,05	10208013	24	10	18	0,07
14	39,20	35,95	10108014	25	8	13	0,05	10208014	26	10	18	0,08
15	41,70	38,48	10108015	28	8	13	0,07	10208015	29	10	18	0,10
16	44,30	41,01	10108016	30	8	14	0,08	10208016	32	10	20	0,13
17	46,80	43,53	10108017	30	8	14	0,09	10208017	34	10	20	0,15
18	49,30	46,07	10108018	30	8	14	0,09	10208018	37	10	20	0,17
19	51,90	48,61	10108019	30	8	14	0,09	10208019	39	10	20	0,20
20	54,40	51,14	10108020	30	8	14	0,10	10208020	40	10	20	0,21
21	57,00	53,68	10108021	35	8	14	0,12	10208021	40	10	20	0,25
22	59,50	56,21	10108022	35	8	14	0,13	10208022	40	10	20	0,26
23	62,00	58,75	10108023	35	8	14	0,13	10208023	40	10	20	0,28
24	64,60	61,29	10108024	35	8	14	0,14	10208024	40	10	20	0,23
25	67,50	63,83	10108025	35	8	14	0,15	10208025	40	10	20	0,31
26	69,50	66,37	10108026	40	10	16	0,19	10208026	50	12	22	0,38
27	72,20	68,91	10108027	40	10	16	0,20	10208027	50	12	22	0,40
28	74,80	71,45	10108028	40	10	16	0,21	10208028	50	12	22	0,42
29	77,30	73,99	10108029	40	10	16	0,22	10208029	50	12	22	0,44
30	79,80	76,53	10108030	40	10	16	0,22	10208030	50	12	22	0,45
31	82,40	79,08	10108031	40	10	16	0,22	10208031	60	12	22	0,58
32	84,90	81,61	10108032	40	10	16	0,23	10208032	60	12	22	0,59
33	87,50	84,16	10108033	40	10	16	0,24	10208033	60	12	22	0,62
34	90,00	86,70	10108034	40	10	16	0,25	10208034	60	12	22	0,64
35	92,50	89,25	10108035	40	10	16	0,25	10208035	60	12	22	0,65
36	95,00	91,79	10108036	40	10	16	0,26	10208036	60	12	22	0,67
37	97,60	94,33	10108037	40	10	16	0,27	10208037	60	12	22	0,71
38	100,20	96,88	10108038	40	10	16	0,28	10208038	60	12	22	0,72
39	102,70	99,42	10108039	40	10	16	0,29	10208039	60	12	22	0,74
40	105,30	101,97	10108040	40	10	16	0,58	10208040	60	12	22	0,77
45	118,00	114,69	10108045	60	12	20	0,67					
48	125,6	122,32	10108048	60	12	20	0,63					
50	130,70	127,41	10108050	60	12	20	1,00					
57	148,60	145,22	10108057	80	14	20	1,53					
76	197,70	193,59	10108076	80	20	25	1,94					

MATERIAL C 45 UNI 7845

From Z 57 to Z 76 the width of the wheel disk increased to $h = 4\text{mm}$

CAD drawings available on our site
www.chiaravalli.com

Quantity, availability and prices
 on B2B Chiaravalli



CHAIN SPROCKETS 8 x 3 mm for roller chains in compliance with DIN 8187 - ISO/R 606



3/8" x 7/32"

CHAIN SPROCKETS

Tooth radius r_3	10	mm
Radius width $\overset{\curvearrowright}{C}$	1	mm
Sprockets tooth width B_1	5,3	mm
Sprockets tooth width b_1	5,2	mm
Sprockets tooth width B_2	15,4	mm
Sprockets tooth width B_3	25,6	mm

CHAIN

Pitch	9,525	mm
Inner width	5,72	mm
Roller \varnothing	6,35	mm

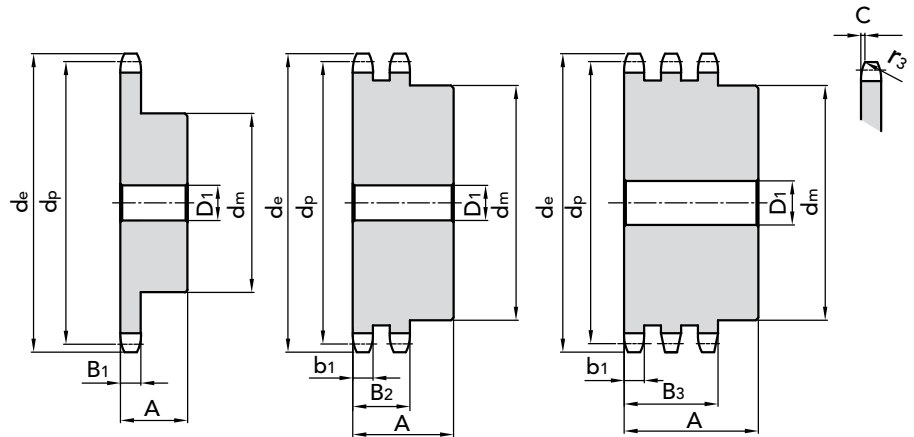

SIMPLEX

DUPLEX

TRIPLEX

Z	d _e	d _p	PART NUMBER	d _m	D ₁	A	kg.	PART NUMBER	d _m	D ₁	A	kg.	PART NUMBER	d _m	D ₁	A	kg.
8	28,54	24,89	10109008	15	6	22	0,03	10209008	15	6	22	0,04	10309008	15	6	32	0,05
9	31,50	27,85	10109009	18	8	22	0,04	10209009	18	8	22	0,05	10309009	18	8	32	0,06
10	34,47	30,82	10109010	20	8	22	0,05	10209010	20	8	22	0,07	10309010	20	10	32	0,09
11	37,46	33,81	10109011	22	8	25	0,08	10209011	22	10	25	0,10	10309011	22	10	35	0,11
12	40,45	36,80	10109012	25	8	25	0,10	10209012	25	10	25	0,13	10309012	25	10	35	0,15
13	43,45	39,80	10109013	28	10	25	0,13	10209013	28	10	25	0,16	10309013	28	10	35	0,18
14	46,45	42,80	10109014	31	10	25	0,16	10209014	31	10	25	0,20	10309014	31	12	35	0,23
15	49,46	45,81	10109015	34	10	25	0,19	10209015	34	10	25	0,24	10309015	34	12	35	0,27
16	52,47	48,82	10109016	37	10	28	0,24	10209016	37	12	30	0,27	10309016	37	12	35	0,35
17	55,49	51,84	10109017	40	10	28	0,28	10209017	40	12	30	0,32	10309017	40	12	35	0,40
18	58,50	54,85	10109018	43	10	28	0,33	10209018	43	12	30	0,38	10309018	43	12	35	0,45
19	61,52	57,87	10109019	45	10	28	0,36	10209019	46	12	30	0,42	10309019	46	12	35	0,50
20	64,54	60,89	10109020	46	10	28	0,39	10209020	49	12	30	0,48	10309020	49	12	35	0,55
21	67,56	63,91	10109021	48	12	28	0,42	10209021	52	12	30	0,52	10309021	52	14	40	0,70
22	70,58	66,93	10109022	50	12	28	0,46	10209022	55	12	30	0,58	10309022	55	14	40	0,80
23	73,60	69,95	10109023	52	12	28	0,50	10209023	58	12	30	0,64	10309023	58	14	40	0,90
24	76,62	72,97	10109024	54	12	28	0,54	10209024	61	12	30	0,71	10309024	61	14	40	0,98
25	79,65	76,00	10109025	57	12	28	0,60	10209025	64	12	30	0,79	10309025	64	14	40	1,05
26	82,67	79,02	10109026	60	12	28	0,66	10209026	67	12	30	0,87	10309026	67	14	40	1,15
27	85,70	82,05	10109027	60	12	28	0,67	10209027	70	12	30	0,94	10309027	70	14	40	1,25
28	88,72	85,07	10109028	60	12	28	0,69	10209028	73	12	30	1,03	10309028	73	14	40	1,35
29	91,75	88,10	10109029	60	12	28	0,70	10209029	76	12	30	1,11	10309029	76	14	40	1,46
30	94,77	91,12	10109030	60	12	30	0,72	10209030	79	12	30	1,20	10309030	79	14	40	1,60
31	97,80	94,15	10109031	65	14	30	0,87	10209031	80	16	30	1,27	10309031	80	16	40	1,70
32	100,83	97,18	10109032	65	14	30	0,89	10209032	80	16	30	1,32	10309032	80	16	40	1,77
33	103,85	100,20	10109033	65	14	30	0,91	10209033	80	16	30	1,37	10309033	80	16	40	1,85
34	106,88	103,23	10109034	65	14	30	0,92	10209034	80	16	30	1,43	10309034	85	16	40	2,00
35	109,91	106,26	10109035	65	14	30	0,95	10209035	80	16	30	1,49	10309035	85	16	40	2,15
36	112,94	109,29	10109036	70	16	30	1,05	10209036	90	16	30	1,70	10309036	90	16	40	2,25
37	115,97	112,32	10109037	70	16	30	1,09	10209037	90	16	30	1,76	10309037	90	16	40	2,30
38	118,99	115,34	10109038	70	16	30	1,10	10209038	90	16	30	1,81	10309038	90	16	40	2,55
39	122,02	118,37	10109039	70	16	30	1,12	10209039	90	16	30	1,88	10309039	90	16	40	2,65
40	125,05	121,40	10109040	70	16	30	1,14	10209040	90	16	30	1,95	10309040	90	16	40	2,80
42	131,11	127,46	10109042	80	16	35	1,56	10209042	90	16	40	2,44					
45	140,20	136,55	10109045	80	16	35	1,66	10209045	90	16	40	3,15	10309045	90	16	56	4,72
48	149,29	145,64	10109048	80	16	35	1,75	10209048	90	16	40	3,43					
50	155,34	151,69	10109050	80	16	35	1,80	10209050	90	16	40	3,53	10309050	90	16	56	5,29
57	176,56	172,91	10109057	80	16	35	1,96	10209057	90	16	40	4,16	10309057	90	16	56	6,24
60	185,65	182,00	10109060	80	16	35	2,03	10209060	90	16	40	4,45	10309060	90	20	56	6,67
76	234,14	230,49	10109076	80	20	35	2,67	10209076	90	20	40	6,23	10309076	100	20	56	9,34

MATERIAL **C 45 UNI 7845**
FOR MONOLITHIC CHAIN SPROCKETS

MATERIAL **FE**
FOR CHAIN SPROCKETS WITH WELDED HUB

CAD drawings available on our site
www.chiaravalli.com

Quantity, availability and prices
on B2B Chiaravalli





1/2" x 1/8"

CHAIN SPROCKETS

Tooth radius r_3	13	mm
Radius width \bar{C}	1	mm
Sprockets tooth width B_1	3	mm

CHAIN

Pitch	12,7	mm
Inner width	3,3	mm
Roller \varnothing	7,75	mm

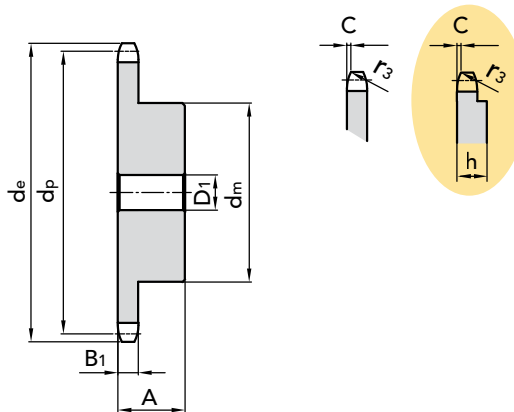

SIMPLEX

Z	d _e	d _p	PART NUMBER	d _m	D ₁	A	kg.
8	38,44	33,18	10110008	21	8	14	0,04
9	42,38	37,13	10110009	25	8	14	0,06
10	46,35	41,10	10110010	28	8	14	0,07
11	50,33	45,07	10110011	31	8	16	0,10
12	54,32	49,07	10110012	35	8	16	0,13
13	58,32	53,06	10110013	39	8	16	0,16
14	62,32	57,07	10110014	43	8	16	0,19
15	66,33	61,09	10110015	47	8	16	0,23
16	70,35	65,10	10110016	50	10	18	0,29
17	74,37	69,11	10110017	50	10	18	0,30
18	78,39	73,14	10110018	50	10	18	0,31
19	82,41	77,16	10110019	50	10	18	0,32
20	86,43	81,19	10110020	50	10	18	0,33
21	90,46	85,22	10110021	60	12	20	0,48
22	94,49	89,24	10110022	60	12	20	0,49
23	98,52	93,27	10110023	60	12	20	0,51
24	102,55	97,29	10110024	60	12	20	0,52
25	106,58	101,33	10110025	60	12	20	0,53
26	110,61	105,36	10110026	70	16	20	0,67
27	114,65	109,40	10110027	70	16	20	0,69
28	118,68	113,42	10110028	70	16	20	0,70
29	122,71	117,46	10110029	70	16	20	0,72
30	126,75	121,50	10110030	70	16	20	0,74
31	130,76	125,54	10110031	70	16	20	0,76
32	134,82	129,56	10110032	70	16	20	0,77
33	138,86	133,60	10110033	70	16	20	0,79
34	142,89	137,64	10110034	70	16	20	0,81
35	146,93	141,68	10110035	70	16	20	0,83
36	150,97	145,72	10110036	70	16	25	1,00
37	155,00	149,76	10110037	70	16	25	1,02
38	159,04	153,80	10110038	70	16	25	1,04
39	163,08	157,83	10110039	70	16	25	1,06
40	167,12	161,87	10110040	70	16	25	1,09

MATERIAL **C 45 UNI 7845**

From **Z 31** the width of the disk wheel is increased to **h = 5mm**

CAD drawings available on our site
www.chiaravalli.com

Quantity, availability and prices
 on B2B Chiaravalli



CHAIN SPROCKETS 1/2" x 1/8" for roller chains in compliance with DIN 8187 - ISO/R 606



1/2" x 3/16"

CHAIN SPROCKETS

Tooth radius r_3	13	mm
Radius width \bar{C}	1,3	mm
Sprockets tooth width B_1	4,5	mm

CHAIN

Pitch	12,7	mm
Inner width	4,88	mm
Roller \varnothing	7,75	mm

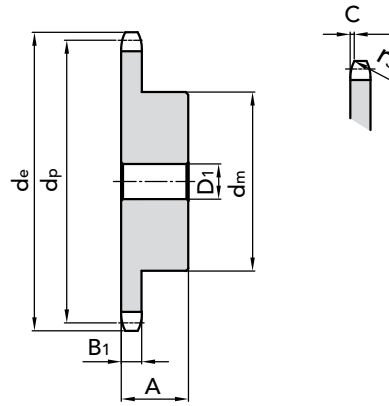

SIMPLEX

Z	d _e	d _p	PART NUMBER	d _m	D ₁	A	kg.
8	38,50	33,18	10111008	21	8	14	0,02
9	41,50	37,13	10111009	25	8	14	0,03
10	46,20	41,10	10111010	28	8	14	0,04
11	49,60	45,07	10111011	31	8	16	0,05
12	53,90	49,07	10111012	35	8	16	0,05
13	58,40	53,06	10111013	39	8	16	0,06
14	62,80	57,07	10111014	43	8	16	0,08
15	66,80	61,09	10111015	47	8	16	0,09
16	70,90	65,10	10111016	50	10	18	0,10
17	74,90	69,11	10111017	50	10	18	0,12
18	78,90	73,14	10111018	50	10	18	0,13
19	82,90	77,16	10111019	50	10	18	0,15
20	86,90	81,19	10111020	50	10	18	0,16
21	91,00	85,22	10111021	60	12	20	0,18
22	95,00	89,24	10111022	60	12	20	0,20
23	99,00	93,27	10111023	60	12	20	0,22
24	103,00	97,29	10111024	60	12	20	0,24
25	107,10	101,33	10111025	60	12	20	0,26
26	111,20	105,36	10111026	70	16	20	0,28
27	115,40	109,40	10111027	70	16	20	0,30
28	119,40	113,42	10111028	70	16	20	0,33
29	123,40	117,46	10111029	70	16	20	0,35
30	127,50	121,50	10111030	70	16	20	0,38
31	131,50	125,54	10111031	70	16	20	0,40
32	135,50	129,56	10111032	70	16	20	0,43
33	139,60	133,60	10111033	70	16	20	0,46
34	143,60	137,64	10111034	70	16	20	0,49
35	147,60	141,68	10111035	70	16	20	0,52
36	151,70	145,72	10111036	70	16	25	0,55
37	155,70	149,76	10111037	70	16	25	0,58
38	159,80	153,80	10111038	70	16	25	0,62
39	163,80	157,83	10111039	70	16	25	0,65
40	167,80	161,87	10111040	70	16	25	0,68

MATERIAL C 45 UNI 7845

CAD drawings available on our site
www.chiaravalli.com

Quantity, availability and prices
 on B2B Chiaravalli





1/2" x 1/4" rullo 7.75

CHAIN SPROCKETS

Tooth radius r_3	13	mm
Radius width \bar{C}	1,3	mm
Sprockets tooth width B_1	5,9	mm

CHAIN

Pitch	12,7	mm
Inner width	6,4	mm
Roller \varnothing	7,75	mm

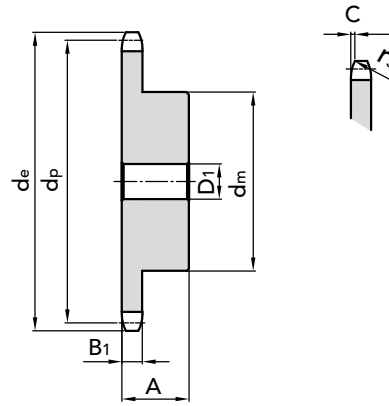

SIMPLEX

Z	d _e	d _p	PART NUMBER	d _m	D ₁	A	kg.
15							
16							
17	74,37	69,11	10113017	52	8	28	0,51
21	90,46	85,22	10113021	68	8	28	0,83
22	94,49	89,24	10113022	70	8	28	0,90
23	98,52	93,27	10113023	70	8	28	0,94
25							
26	110,61	105,36	10113026	70	8	30	1,09
27							
28	118,68	113,42	10113028	70	10	30	1,13
29							
30	126,75	121,50	10113030	80	10	30	1,41
31	130,78	125,54	10113031	90	10	30	1,22
32							
33							
34	142,89	137,64	10113034	90	10	30	1,83
35	146,93	141,68	10113035	90	10	30	1,89
36	150,97	145,72	10113036	90	10	30	2,14
38	159,04	153,80	10113038	90	12	35	2,22
39							
40							

MATERIAL C 45 UNI 7845

CAD drawings available on our site
www.chiaravalli.com

Quantity, availability and prices
 on B2B Chiaravalli



CHAIN SPROCKETS 1/2" x 1/4" rullo 7.75 for roller chains in compliance with DIN 8187 - ISO/R 606

1/2" x 1/4" rullo 8.51
CHAIN SPROCKETS

Tooth radius r_3	13	mm
Radius width \bar{C}	1,3	mm
Sprockets tooth width B_1	5,9	mm

CHAIN

Pitch	12,7	mm
Inner width	6,4	mm
Roller \varnothing	8,51	mm

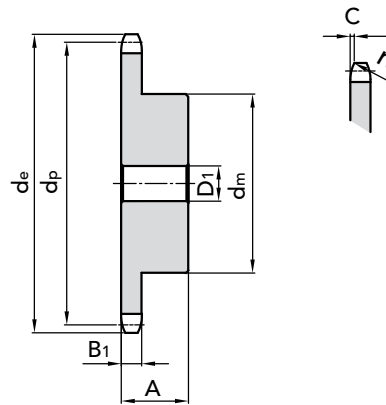
SIMPLEX

Z	d_e	d_p	PART NUMBER	d_m	D_1	A	kg.
8	37,68	33,19	10114008	20	8	25	0,45
9	41,62	37,13	10114009	24	8	25	0,48
11							
15	65,57	61,08	10114015	45	8	28	0,53
16							
17							
19	81,65	77,16	10114019	60	8	28	0,59
21							
22	93,73	89,24	10114022	70	10	28	0,78
23	97,76	93,27	10114023	70	10	28	0,91
25	105,82	101,33	10114025	70	10	28	0,98
26	109,85	105,36	10114026	70	10	30	1,01
27	113,89	109,40	10114027	70	10	30	1,04
28	117,92	113,43	10114028	70	10	30	1,18
29	121,95	117,46	10114029	80	10	30	1,25
30							
31	130,02	125,53	10114031	90	10	30	1,39
32	134,06	129,57	10114032	90	10	30	1,44
33	138,10	133,61	10114033	90	12	30	1,49
34							
35							
36	150,21	145,72	10114036	90	12	35	1,64
38	158,28	153,79	10114038	90	12	35	1,66
39							
40	166,36	161,87	10114040	90	12	35	1,78

 MATERIAL **C 45 UNI 7845**

 CAD drawings available on our site
www.chiaravalli.com

 Quantity, availability and prices
 on B2B Chiaravalli





1/2" x 5/16"

CHAIN SPROCKETS

Tooth radius r_3	13	mm
Radius width \bar{C}	1,3	mm
Sprockets tooth width B_1	7,2	mm
Sprockets tooth width b_1	7	mm
Sprockets tooth width B_2	21	mm
Sprockets tooth width B_3	34,9	mm

CHAIN

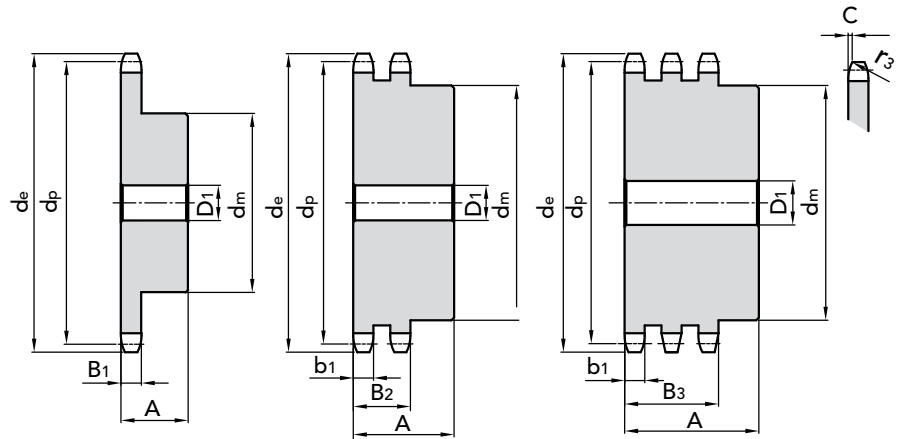
Pitch	12,7	mm
Inner width	7,75	mm
Roller \varnothing	8,51	mm



SIMPLEX

DUPLEX

TRIPLEX

Z	d_e	d_p	PART NUMBER	d_m	D_1	A	kg.	PART NUMBER	d_m	D_1	A	kg.	PART NUMBER	d_m	D_1	A	kg.
8	37,68	33,18	10112008	20	10	25	0,06	10212008	20	10	32	0,09	10312008	20	10	46	0,13
9	41,62	37,13	10112009	24	10	25	0,09	10212009	24	10	32	0,13	10312009	24	12	46	0,18
10	45,59	41,10	10112010	26	10	25	0,12	10212010	28	10	32	0,18	10312010	28	12	46	0,24
11	49,57	45,07	10112011	29	10	25	0,15	10212011	32	12	35	0,24	10312011	32	14	50	0,31
12	53,56	49,07	10112012	33	10	28	0,21	10212012	35	12	35	0,30	10312012	35	14	50	0,39
13	57,56	53,06	10112013	37	10	28	0,26	10212013	38	12	35	0,36	10312013	38	14	50	0,49
14	61,56	57,07	10112014	41	10	28	0,32	10212014	42	12	35	0,44	10312014	42	14	50	0,60
15	65,57	61,09	10112015	45	10	28	0,38	10212015	46	12	35	0,52	10312015	46	14	50	0,72
16	69,59	65,10	10112016	50	12	28	0,46	10212016	50	14	35	0,63	10312016	50	16	50	0,85
17	73,61	69,11	10112017	52	12	28	0,51	10212017	54	14	35	0,73	10312017	54	16	50	0,99
18	77,63	73,14	10112018	56	12	28	0,59	10212018	58	14	35	0,85	10312018	58	16	50	1,14
19	81,65	77,16	10112019	60	12	28	0,67	10212019	62	14	35	0,97	10312019	62	16	50	1,30
20	85,67	81,19	10112020	64	12	28	0,76	10212020	66	14	35	1,10	10312020	66	16	50	1,47
21	89,70	85,22	10112021	68	12	28	0,85	10212021	70	16	40	1,29	10312021	70	20	55	1,79
22	93,73	89,24	10112022	70	12	28	0,91	10212022	70	16	40	1,37	10312022	70	20	55	1,93
23	97,76	93,27	10112023	70	14	28	0,95	10212023	70	16	40	1,46	10312023	70	20	55	2,08
24	101,79	97,29	10112024	70	14	28	0,98	10212024	75	16	40	1,64	10312024	75	20	55	2,32
25	105,82	101,33	10112025	70	14	28	1,01	10212025	80	16	40	1,82	10312025	80	20	55	2,57
26	109,85	105,36	10112026	70	16	30	1,09	10212026	85	20	40	2,02	10312026	85	20	55	2,79
27	113,89	109,40	10112027	70	16	30	1,13	10212027	85	20	40	2,12	10312027	85	20	55	2,96
28	117,92	113,42	10112028	70	16	30	1,17	10212028	90	20	40	2,34	10312028	90	20	55	3,25
29	121,95	117,46	10112029	80	16	30	1,42	10212029	95	20	40	2,56	10312029	95	20	55	3,55
30	125,99	121,50	10112030	80	16	30	1,46	10212030	100	20	40	2,79	10312030	100	20	55	3,86
31	130,02	125,54	10112031	90	16	30	1,74	10212031	100	20	40	2,87	10312031	110	20	55	4,42
32	134,04	129,56	10112032	90	16	30	1,78	10212032	100	20	40	3,00	10312032	110	20	55	4,53
33	138,10	133,60	10112033	90	16	30	1,83	10212033	100	20	40	3,13	10312033	110	20	55	4,74
34	142,13	137,64	10112034	90	16	30	1,88	10212034	100	20	40	3,26	10312034	110	20	55	4,97
35	146,17	141,68	10112035	90	16	30	1,93	10212035	100	20	40	3,40	10312035	110	20	55	5,20
36	150,21	145,72	10112036	90	16	35	2,22	10212036	110	20	40	3,54	10312036	120	25	55	5,64
37	154,24	149,76	10112037	90	16	35	2,27	10212037	110	20	40	3,69	10312037	120	25	55	5,88
38	158,28	153,80	10112038	90	16	35	2,32	10212038	110	20	40	3,84	10312038	120	25	55	6,14
39	162,32	157,83	10112039	90	16	35	2,38	10212039	110	20	40	4,00	10312039	120	25	55	6,40
40	166,36	161,87	10112040	90	16	35	2,43	10212040	110	20	40	4,15	10312040	120	25	55	6,66
42	174,43	169,94	10112042	90	20	40	2,80	10212042	110	20	50	5,67					
45	186,50	182,06	10112045	90	20	40	3,10	10212045	110	20	50	6,26	10312045	110	25	60	9,12
48	198,67	194,18	10112048	90	20	40	3,30	10212048	110	20	50	6,75					
50	206,75	202,26	10112050	90	20	40	3,50	10212050	110	20	50	7,17	10312050	110	25	60	10,74
57	235,03	230,54	10112057	90	20	40	4,10	10212057	110	25	50	8,65	10312057	110	25	60	13,26
60	247,15	242,66	10112060	90	20	40	4,30	10212060	110	25	50	9,35	10312060	110	25	60	14,40
76	311,81	307,32	10112076	90	25	40	5,80	10212076	110	25	56	13,3	10312076	110	25	60	21,78

MATERIAL **C 45 UNI 7845**
FOR MONOLITHIC CHAIN SPROCKETS

MATERIAL **FE**
FOR CHAIN SPROCKETS WITH WELDED HUB

CAD drawings available on our site
www.chiaravalli.com

Quantity, availability and prices
on B2B Chiaravalli



CHAIN SPROCKETS 1/2" x 5/16" for roller chains in compliance with DIN 8187 - ISO/R 606



5/8" x 3/8"

CHAIN SPROCKETS

Tooth radius r_3	16	mm
Radius width \bar{C}	1,6	mm
Sprockets tooth width B_1	9,1	mm
Sprockets tooth width b_1	9	mm
Sprockets tooth width B_2	25,5	mm
Sprockets tooth width B_3	42,1	mm

CHAIN

Pitch	15,875	mm
Inner width	9,65	mm
Roller \varnothing	10,16	mm

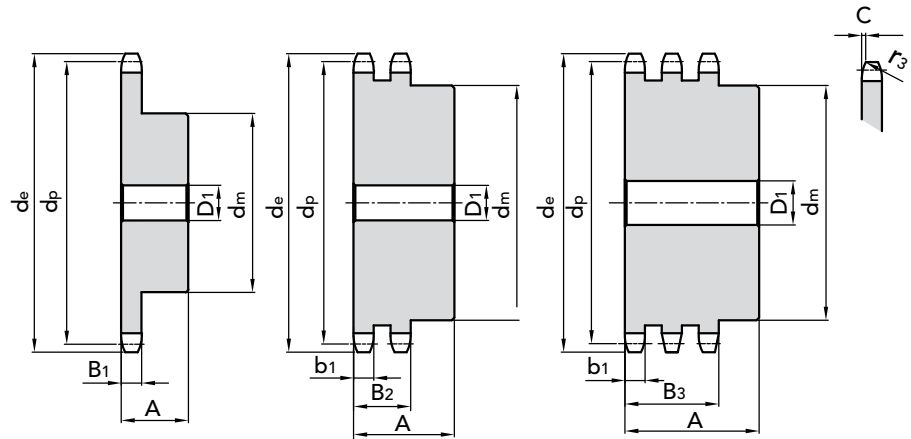

SIMPLEX

DUPLEX

TRIPLEX

Z	d_e	d_p	PART NUMBER	d_m	D_1	A	kg.	PART NUMBER	d_m	D_1	A	kg.	PART NUMBER	d_m	D_1	A	kg.
8	48,32	41,48	10115008	25	10	25	0,12	10215008	25	12	40	0,19	10315008	25	12	55	0,27
9	53,26	46,42	10115009	30	10	25	0,16	10215009	30	12	40	0,27	10315009	30	12	55	0,38
10	58,21	51,37	10115010	35	10	25	0,22	10215010	35	12	40	0,36	10315010	35	16	55	0,47
11	63,19	56,35	10115011	37	12	30	0,29	10215011	39	14	40	0,43	10315011	39	16	55	0,61
12	68,18	61,34	10115012	42	12	30	0,37	10215012	44	14	40	0,55	10315012	44	16	55	0,78
13	73,17	66,33	10115013	47	12	30	0,46	10215013	49	14	40	0,68	10315013	49	16	55	0,96
14	78,18	71,34	10115014	52	12	30	0,56	10215014	54	14	40	0,82	10315014	54	16	55	1,15
15	83,19	76,35	10115015	57	12	30	0,67	10215015	59	14	40	0,97	10315015	59	16	55	1,37
16	88,21	81,37	10115016	60	12	30	0,76	10215016	64	16	45	1,26	10315016	64	16	60	1,72
17	93,23	86,39	10115017	60	12	30	0,88	10215017	69	16	45	1,46	10315017	69	16	60	1,99
18	98,26	91,42	10115018	70	14	30	1,01	10215018	74	16	45	1,67	10315018	74	16	60	2,27
19	103,29	96,45	10115019	70	14	30	1,15	10215019	79	16	45	1,90	10315019	79	16	60	2,58
20	108,32	101,48	10115020	75	14	30	1,21	10215020	84	16	45	2,14	10315020	84	16	60	2,91
21	113,35	106,51	10115021	75	16	30	1,35	10215021	85	16	45	2,27	10315021	85	20	60	3,12
22	118,39	111,55	10115022	80	16	30	1,41	10215022	90	16	45	2,54	10315022	90	20	60	3,48
23	123,43	116,59	10115023	80	16	30	1,47	10215023	95	16	45	2,82	10315023	95	20	60	3,48
24	128,46	121,62	10115024	80	16	30	1,54	10215024	100	16	45	3,11	10315024	100	20	60	4,86
25	133,50	126,66	10115025	80	16	30	1,60	10215025	105	16	45	3,15	10315025	105	20	60	4,25
26	138,54	131,70	10115026	85	20	35	1,96	10215026	110	16	45	3,74	10315026	110	20	60	4,67
27	143,58	136,74	10115027	85	20	35	2,04	10215027	110	20	45	3,94	10315027	110	20	60	5,10
28	148,63	141,79	10115028	90	20	35	2,25	10215028	115	20	45	4,28	10315028	115	20	60	5,43
29	153,67	146,83	10115029	90	20	35	2,33	10215029	115	20	45	4,50	10315029	115	20	60	5,90
30	158,71	151,87	10115030	90	20	35	2,41	10215030	120	20	45	4,87	10315030	120	20	60	6,25
31	163,76	156,92	10115031	95	20	35	2,64	10215031	120	20	45	5,10	10315031	120	20	60	7,18
32	168,80	161,96	10115032	95	20	35	2,73	10215032	120	20	45	5,34	10315032	120	20	60	7,56
33	173,85	167,01	10115033	95	20	35	2,82	10215033	120	20	45	5,59	10315033	120	20	60	7,97
34	178,89	172,05	10115034	95	20	35	2,92	10215034	120	20	45	5,84	10315034	120	20	60	8,36
35	183,94	177,10	10115035	95	20	35	3,01	10215035	120	20	45	6,11	10315035	120	20	60	8,74
36	188,99	182,15	10115036	100	20	35	3,27	10215036	120	20	45	6,38	10315036	120	25	60	9,15
37	194,03	187,19	10115037	100	20	35	3,37	10215037	120	20	45	6,66	10315037	120	25	60	9,61
38	199,08	192,24	10115038	100	20	35	3,47	10215038	120	20	45	6,95	10315038	120	25	60	10,08
39	204,13	197,29	10115039	100	20	35	3,58	10215039	120	20	45	7,25	10315039	120	25	60	10,57
40	209,17	202,33	10115040	100	20	35	3,69	10215040	120	20	45	7,55	10315040	120	25	60	11,97
42	219,27	212,43	10115042	100	20	40	4,73	10215042	130	20	50	9,35					
45	234,42	227,58	10115045	100	20	40	5,09	10215045	130	20	50	10,32	10315045	130	25	60	15,70
48	249,57	242,73	10115048	100	20	40	5,43	10215048	130	20	50	11,40					
50	259,66	252,82	10115050	100	20	40	5,70	10215050	130	20	50	12,11	10315050	130	25	60	18,83
57	295,02	288,18	10115057	100	20	40	6,66	10215057	130	20	50	15,74	10315057	130	25	60	23,40
60	310,17	303,33	10115060	100	20	40	7,15	10215060	130	20	50	16,40	10315060	130	25	60	25,80
76	390,99	384,15	10115076	100	20	50	10,28	10215076	130	20	63	24,93	10315076	130	25	67	40,25

MATERIAL **C 45 UNI 7845**
FOR MONOLITHIC CHAIN SPROCKETS

MATERIAL **FE**
FOR CHAIN SPROCKETS WITH WELDED HUB

CAD drawings available on our site
www.chiaravalli.com

Quantity, availability and prices
on B2B Chiaravalli





3/4" x 7/16"

CHAIN SPROCKETS

Tooth radius r_3	19	mm
Radius width \check{C}	2	mm
Sprockets tooth width B_1	11,1	mm
Sprockets tooth width b_1	10,8	mm
Sprockets tooth width B_2	30,3	mm
Sprockets tooth width B_3	49,8	mm

CHAIN

Pitch	19,05	mm
Inner width	11,68	mm
Roller \varnothing	12,07	mm

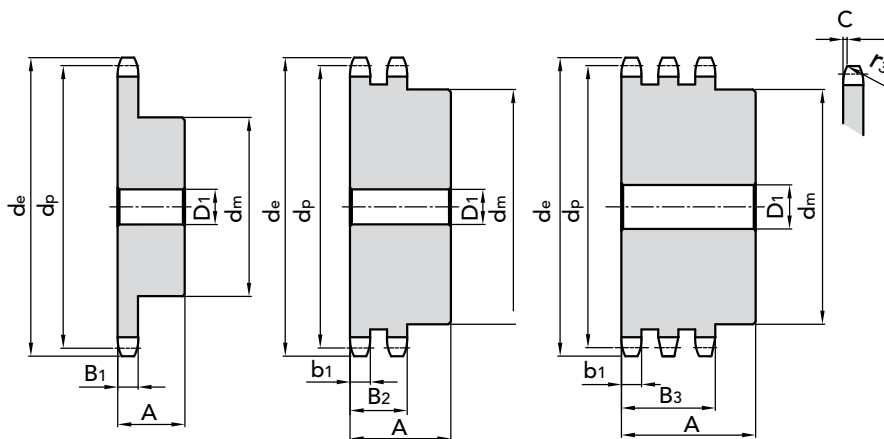

SIMPLEX

DUPLEX

TRIPLEX

Z	d _e	d _p	PART NUMBER	d _m	D ₁	A	kg.	PART NUMBER	d _m	D ₁	A	kg.	PART NUMBER	d _m	D ₁	A	kg.
8	57,31	49,78	10119008	31	12	30	0,21	10219008	31	12	45	0,31	10319008	31	16	65	0,45
9	63,23	55,70	10119009	37	12	30	0,29	10219009	37	12	45	0,44	10319009	37	16	65	0,64
10	69,18	61,65	10119010	42	12	30	0,38	10219010	42	12	45	0,59	10319010	42	16	65	0,86
11	75,15	67,62	10119011	46	14	35	0,51	10219011	47	16	50	0,81	10319011	47	20	70	1,09
12	81,13	73,60	10119012	52	14	35	0,65	10219012	53	16	50	1,02	10319012	53	20	70	1,39
13	87,13	79,60	10119013	58	14	35	0,80	10219013	59	16	50	1,25	10319013	59	20	70	1,72
14	93,14	85,61	10119014	64	14	35	0,97	10219014	65	16	50	1,46	10319014	65	20	70	2,08
15	99,16	91,63	10119015	70	14	35	1,16	10219015	71	16	50	1,74	10319015	71	20	70	2,47
16	105,18	97,65	10119016	75	16	35	1,34	10219016	77	20	50	2,03	10319016	77	20	70	2,89
17	111,20	103,67	10119017	80	16	35	1,53	10219017	83	20	50	2,36	10319017	83	20	70	3,34
18	117,23	109,70	10119018	80	16	35	1,62	10219018	89	20	50	2,70	10319018	89	20	70	3,83
19	123,27	115,74	10119019	80	16	35	1,70	10219019	95	20	50	3,07	10319019	95	20	70	4,35
20	129,31	121,78	10119020	80	16	35	1,80	10219020	100	20	50	3,43	10319020	100	20	70	4,87
21	135,35	127,82	10119021	90	20	40	2,35	10219021	100	20	50	3,69	10319021	100	20	70	5,20
22	141,39	133,86	10119022	90	20	40	2,46	10219022	100	20	50	3,97	10319022	100	20	70	5,65
23	147,43	139,90	10119023	90	20	40	2,56	10219023	110	20	50	4,51	10319023	110	20	70	6,38
24	153,48	145,95	10119024	90	20	40	2,68	10219024	110	20	50	4,81	10319024	110	20	70	6,87
25	159,52	151,99	10119025	90	20	40	2,80	10219025	120	20	50	5,41	10319025	120	20	70	7,77
26	165,57	158,04	10119026	95	20	40	3,08	10219026	120	20	50	5,73	10319026	120	20	70	8,21
27	171,62	164,09	10119027	95	20	40	3,21	10219027	120	20	50	6,08	10319027	120	20	70	8,77
28	177,67	170,14	10119028	95	20	40	3,34	10219028	120	20	50	6,43	10319028	120	20	70	9,35
29	183,72	176,19	10119029	95	20	40	3,48	10219029	120	20	50	6,80	10319029	120	20	70	9,96
30	189,78	182,25	10119030	95	20	40	3,63	10219030	120	20	50	7,19	10319030	120	20	70	10,59
31	195,83	188,30	10119031	100	20	40	3,78	10219031	130	20	50	7,59	10319031	130	25	70	11,55
32	201,88	194,35	10119032	100	20	40	3,93	10219032	130	20	50	8,00	10319032	130	25	70	12,22
33	207,94	200,41	10119033	100	20	40	4,09	10219033	130	20	50	8,42	10319033	130	25	70	12,92
34	213,99	206,46	10119034	100	20	40	4,25	10219034	130	20	50	8,86	10319034	130	25	70	13,64
35	220,05	212,52	10119035	100	20	40	4,42	10219035	130	20	50	9,31	10319035	130	25	70	14,38
36	226,10	218,57	10119036	100	20	40	4,71	10219036	130	25	50	9,71	10319036	130	25	70	15,14
37	232,16	224,63	10119037	100	20	40	4,89	10219037	130	25	50	10,19	10319037	130	25	70	15,93
38	238,22	230,69	10119038	100	20	40	5,07	10219038	130	25	50	10,78	10319038	130	25	70	16,73
39	244,27	236,74	10119039	100	20	40	5,26	10219039	130	25	50	11,19	10319039	130	25	70	17,57
40	250,33	242,80	10119040	100	20	40	5,46	10219040	130	25	50	11,71	10319040	130	25	70	18,42
42	262,45	254,92	10119042	110	25	56	8,14	10219042	140	25	63	14,51					
45	280,62	273,09	10119045	110	25	56	8,85	10219045	140	25	63	16,35	10319045	140	25	70	23,55
48	298,80	291,27	10119048	110	25	56	9,67	10219048	140	25	63	18,18					
50	310,92	303,39	10119050	110	25	56	10,15	10219050	140	25	63	19,44	10319050	140	25	70	28,73
57	353,34	345,81	10119057	110	25	56	11,85	10219057	140	25	63	24,43	10319057	140	25	70	37,16
60	371,52	363,99	10119060	110	25	56	12,71	10219060	140	25	63	26,77	10319060	140	30	70	41,01
76	468,51	460,98	10119076	110	30	56	18,02	10219076	140	30	63	41,88	10319076	140	30	70	65,41

MATERIAL **C 45 UNI 7845**
FOR MONOLITHIC CHAIN SPROCKETS

MATERIAL **FE**
FOR CHAIN SPROCKETS WITH WELDED HUB

CAD drawings available on our site
www.chiaravalli.com

Quantity, availability and prices
on B2B Chiaravalli



CHAIN SPROCKETS 3/4" x 7/16" for roller chains in compliance with DIN 8187 - ISO/R 606

1" x 17.02 mm
CHAIN SPROCKETS

Tooth radius r_3	26	mm
Radius width \check{C}	2,5	mm
Sprockets tooth width B_1	16,2	mm
Sprockets tooth width b_1	15,8	mm
Sprockets tooth width B_2	47,7	mm
Sprockets tooth width B_3	79,6	mm

CHAIN

Pitch	25,4	mm
Inner width	17,02	mm
Roller \varnothing	15,88	mm

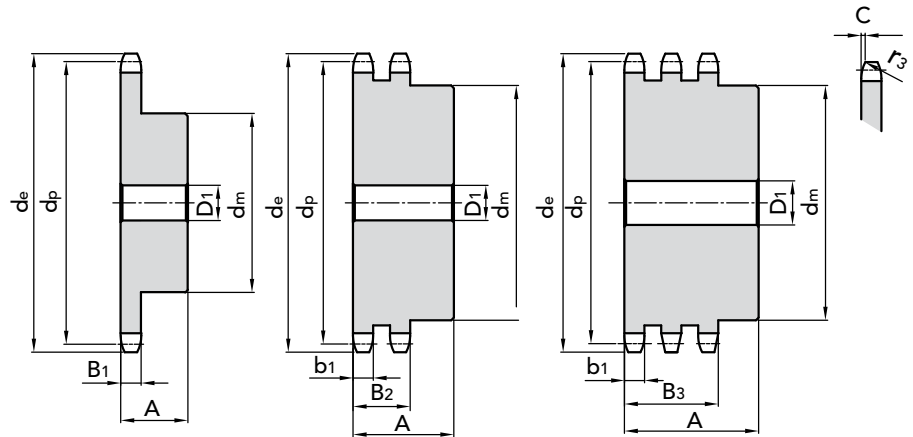

Z	d_e	d_p	SIMPLEX				DUPLEX				TRIPLEX						
			PART NUMBER	d_m	D_1	A	kg.	PART NUMBER	d_m	D_1	A	kg.	PART NUMBER	d_m	D_1	A	kg.
8	77,49	66,37	10125008	42	16	35	0,47	10225008	42	16	65	0,81	10325008	42	20	95	1,19
9	85,38	74,26	10125009	50	16	35	0,66	10225009	50	16	65	1,15	10325009	50	20	95	1,68
10	93,32	82,20	10125010	55	16	35	0,83	10225010	56	16	65	1,52	10325010	56	20	95	2,24
11	101,28	90,16	10125011	61	16	40	1,14	10225011	64	20	70	2,08	10325011	64	25	100	2,86
12	109,26	98,14	10125012	69	16	40	1,43	10225012	72	20	70	2,60	10325012	72	25	100	3,62
13	117,26	106,14	10125013	78	16	40	1,77	10225013	80	20	70	3,18	10325013	80	25	100	4,45
14	125,27	114,15	10125014	84	16	40	2,08	10225014	88	20	70	3,82	10325014	88	25	100	5,37
15	133,29	122,17	10125015	92	20	40	2,46	10225015	96	20	70	4,51	10325015	96	25	100	6,37
16	141,32	130,20	10125016	100	20	45	3,14	10225016	104	20	70	5,17	10325016	104	30	100	7,45
17	149,35	138,23	10125017	100	20	45	3,33	10225017	112	20	70	5,98	10325017	112	30	100	8,60
18	157,39	146,27	10125018	100	20	45	3,56	10225018	120	20	70	6,84	10325018	120	30	100	9,84
19	165,44	154,32	10125019	100	20	45	3,78	10225019	128	20	70	7,76	10325019	128	30	100	11,16
20	173,49	162,37	10125020	100	20	45	4,03	10225020	130	20	70	8,52	10325020	130	30	100	12,36
21	181,54	170,42	10125021	110	20	50	5,01	10225021	130	25	70	9,24	10325021	130	30	100	13,56
22	189,60	178,48	10125022	110	20	50	5,28	10225022	130	25	70	10,00	10325022	130	30	100	14,82
23	197,66	186,54	10125023	110	20	50	5,56	10225023	130	25	70	10,8	10325023	130	30	100	16,15
24	205,72	194,60	10125024	110	20	50	5,86	10225024	130	25	70	11,64	10325024	130	30	100	17,53
25	213,78	202,66	10125025	110	20	50	6,16	10225025	130	25	70	12,52	10325025	130	30	100	18,99
26	221,84	210,72	10125026	120	20	50	6,96	10225026	130	25	70	13,43	10325026	130	30	100	20,34
27	229,91	218,79	10125027	120	20	50	7,30	10225027	130	25	70	14,38	10325027	130	30	100	21,92
28	237,98	226,86	10125028	120	20	50	7,64	10225028	130	25	70	15,38	10325028	130	30	100	23,57
29	246,05	234,93	10125029	120	20	50	8,00	10225029	130	25	70	16,41	10325029	130	30	100	25,27
30	254,12	243,00	10125030	120	20	50	8,38	10225030	130	25	70	17,48	10325030	130	30	100	27,05
31	262,19	251,07	10125031	120	25	50	8,69	10225031	140	25	70	18,96	10325031	140	30	100	29,23
32	270,26	259,14	10125032	120	25	50	9,09	10225032	140	25	70	20,10	10325032	140	30	100	31,13
33	278,33	267,21	10125033	120	25	50	9,50	10225033	140	25	70	21,29	10325033	140	30	100	33,10
34	286,40	275,28	10125034	120	25	50	9,93	10225034	140	25	70	22,21	10325034	140	30	100	35,13
35	294,48	283,36	10125035	120	25	50	10,36	10225035	140	25	70	23,77	10325035	140	30	100	37,23
36	302,55	291,43	10125036	120	25	50	10,81	10225036	140	25	70	25,07	10325036	140	30	100	39,39
37	310,63	299,51	10125037	120	25	50	11,28	10225037	140	25	70	26,41					
38	318,70	307,58	10125038	120	25	50	11,76	10225038	140	25	70	27,79	10325038	140	30	100	43,90
39	326,78	315,66	10125039	120	25	50	12,25	10225039	140	25	70	29,20					
40	334,86	323,74	10125040	120	25	50	12,75	10225040	140	25	70	30,65	10325040	140	30	100	48,67
42	351,01	339,89	10125042	125	25	70	16,54	10225042	150	25	80	33,63					
45	375,24	364,12	10125045	125	25	70	18,15	10225045	150	25	80	38,44	10325045	160	30	100	63,94
48	399,48	388,36	10125048	125	25	70	19,86	10225048	150	30	80	43,61					
50	415,64	404,52	10125050	125	25	70	20,89	10225050	150	30	80	47,25	10325050	160	30	100	78,58
57	472,20	461,08	10125057	125	30	70	25,52	10225057	160	30	90	63,45	10325057	180	40	110	103,03
60	496,45	485,33	10125060	125	30	70	27,76	10225060	160	30	90	70,00					
76	625,76	614,64	10125076	140	30	80	42,97	10225076	160	30	90	110,79	10325076	180	40	110	181,86

MATERIAL **C 45 UNI 7845**
FOR MONOLITHIC CHAIN SPROCKETS

MATERIAL **FE**
FOR CHAIN SPROCKETS WITH WELDED HUB

CAD drawings available on our site
www.chiaravalli.com

Quantity, availability and prices
on B2B Chiaravalli





1" 1/4 x 3/4"

CHAIN SPROCKETS

Tooth radius r_3	32	mm
Radius width \bar{C}	3,5	mm
Sprockets tooth width B_1	18,5	mm
Sprockets tooth width b_1	18,2	mm
Sprockets tooth width B_2	54,6	mm
Sprockets tooth width B_3	91	mm

CHAIN

Pitch	31,75	mm
Inner width	19,56	mm
Roller \varnothing	19,05	mm

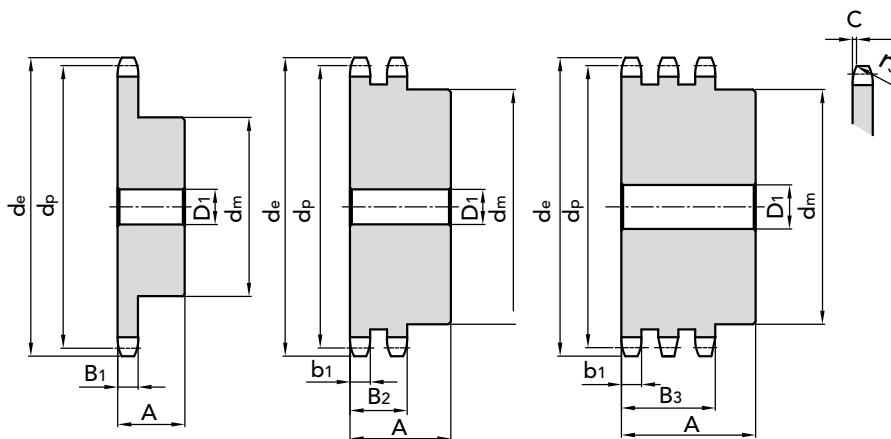

SIMPLEX

DUPLEX

TRIPLEX

Z	d_e	d_p	PART NUMBER	d_m	D_1	A	kg.	PART NUMBER	d_m	D_1	A	kg.	PART NUMBER	d_m	D_1	A	kg.
8	98,10	82,96	10131008	53	20	40	0,85	10231008	53	20	75	1,58	10331008	53	20	110	2,15
9	108,00	92,84	10131009	63	20	40	1,19	10231009	63	20	75	2,19	10331009	63	20	110	3,05
10	117,90	102,74	10131010	70	20	40	1,51	10231010	70	20	75	2,85	10331010	70	20	110	4,04
11	127,80	112,68	10131011	77	20	45	2,05	10231011	80	20	80	3,72	10331011	80	20	115	5,19
12	137,80	122,68	10131012	88	20	45	2,60	10231012	90	20	80	4,66	10331012	90	20	115	6,55
13	147,80	132,65	10131013	98	20	45	3,15	10231013	100	20	80	5,70	10331013	100	20	115	8,06
14	157,80	142,68	10131014	108	20	45	3,80	10231014	110	20	80	6,84	10331014	110	20	115	9,71
15	167,90	152,72	10131015	118	20	45	4,47	10231015	120	20	80	8,08	10331015	120	20	115	11,50
16	177,90	162,75	10131016	120	25	50	5,25	10231016	120	25	80	8,90	10331016	120	25	115	13,06
17	187,90	172,78	10131017	120	25	50	5,60	10231017	120	25	80	9,92	10331017	120	25	115	14,65
18	198,00	182,85	10131018	120	25	50	6,00	10231018	120	25	80	11,00	10331018	120	25	115	16,54
19	208,10	192,91	10131019	120	25	50	6,40	10231019	120	25	80	12,16	10331019	120	25	115	18,45
20	218,10	202,98	10131020	120	25	50	6,85	10231020	120	25	80	13,38	10331020	120	25	115	20,48
21	228,20	213,04	10131021	140	25	55	8,75	10231021	140	25	80	15,49	10331021	140	25	115	23,38
22	238,30	223,11	10131022	140	25	55	9,30	10231022	140	25	80	16,86	10331022	140	25	115	25,64
23	248,30	233,17	10131023	140	25	55	9,77	10231023	140	25	80	18,29	10331023	140	25	115	28,00
24	258,40	243,23	10131024	140	25	55	10,30	10231024	140	25	80	19,79	10331024	140	25	115	30,49
25	268,50	253,33	10131025	140	25	55	10,80	10231025	140	25	80	21,36	10331025	140	25	115	33,09
26	278,60	263,40	10131026	150	25	55	12,09	10231026	150	25	80	23,45	10331026	150	25	115	36,23
27	288,60	273,40	10131027	150	25	55	12,65	10231027	150	25	80	25,15	10331027	150	25	115	39,06
28	298,70	283,56	10131028	150	25	55	13,29	10231028	150	25	80	26,93	10331028	150	25	115	42,00
29	308,80	293,65	10131029	150	25	55	13,93	10231029	150	25	80	28,77	10331029	150	25	115	45,00
30	318,90	303,75	10131030	150	25	55	14,60	10231030	150	25	80	30,69	10331030	150	25	115	48,23
31	329,00	313,85	10131031	160	25	55	15,28	10231031	150	25	80	32,67	10331031	150	25	115	51,50
32	339,10	323,91	10131032	160	25	55	16,00	10231032	150	25	80	32,72	10331032	150	30	115	54,61
33	349,20	334,01	10131033	160	25	55	16,70	10231033	150	25	80	35,00	10331033	150	30	115	58,37
34	359,30	344,10	10131034	160	25	55	17,49	10231034	150	25	80	39,03	10331034	150	30	115	62,06
35	369,40	354,20	10131035	160	25	55	18,30	10231035	150	25	80	41,28	10331035	150	30	115	65,80
36	379,50	364,30	10131036	160	25	55	19,10	10231036	150	30	80	43,61	10331036	150	30	115	69,66
37	389,50	374,39	10131037	160	25	55	19,90						10331037	150	30	115	73,00
38	399,60	384,49	10131038	160	25	55	20,75	10231038	150	30	80	48,46	10331038	150	30	115	77,72
39	409,70	394,59	10131039	160	25	55	21,70	10231039	150	30	80	51,00					
40	419,80	404,68	10131040	160	25	55	22,53	10231040	150	30	80	53,60	10331040	150	30	115	86,24
42	440,00	424,88	10131042	160	30	70	28,84										
45	470,30	455,17	10131045	160	30	70	31,79	10231045	160	30	90	71,32	10331045	180	40	115	110,41
48	500,60	485,46	10131048	160	30	70	32,80										
50	520,80	505,65	10131050	160	30	70	35,00	10231050	160	30	90	87,08	10331050	180	40	115	136,59
57	591,50	576,36	10131057	160	30	80	37,21	10231057	160	30	100	116,28	10331057	180	40	125	181,21
60	621,80	606,65	10131060	160	30	80	45,79										
76	783,50	768,32	10131076	160	30	90	75,81	10231076	180	30	100	200,96	10331076	200	40	140	322,03

MATERIAL **C 45 UNI 7845**
FOR MONOLITHIC CHAIN SPROCKETS

MATERIAL **FE**
FOR CHAIN SPROCKETS WITH WELDED HUB

CAD drawings available on our site
www.chiaravalli.com

Quantity, availability and prices
on B2B Chiaravalli





CHAIN SPROCKETS 1" 1/2 x 1" for roller chains in compliance with DIN 8187 - ISO/R 606

1" 1/2 x 1"

CHAIN SPROCKETS

Tooth radius r_s	38	mm
Radius width \check{C}	4	mm
Sprockets tooth width B_1	24,1	mm
Sprockets tooth width b_1	23,6	mm
Sprockets tooth width B_2	72	mm
Sprockets tooth width B_3	120,3	mm

CHAIN

Pitch	38,1	mm
Inner width	25,4	mm
Roller \varnothing	25,4	mm

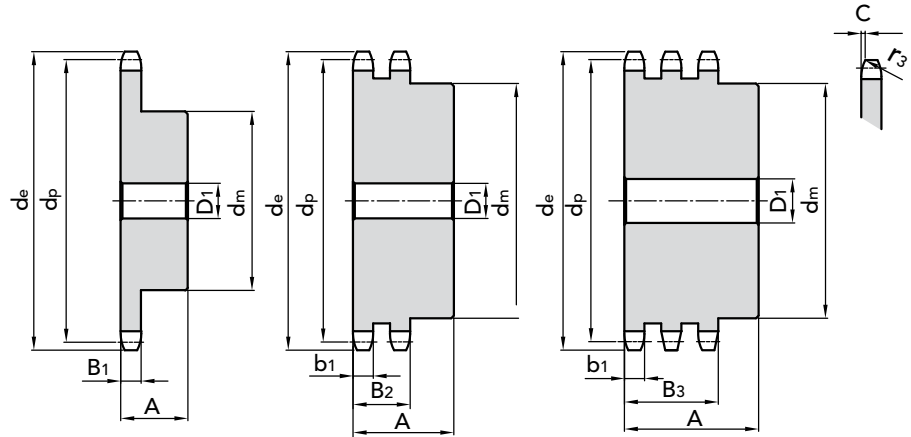

Z	d_e	d_p	SIMPLEX				DUPLEX				TRIPLEX						
			PART NUMBER	d_m	D_1	A	kg.	PART NUMBER	d_m	D_1	A	kg.	PART NUMBER	d_m	D_1	A	kg.
8	115,00	99,55	10138008	58	20	45	1,38	10238008	58	25	95	2,70	10338008	58	25	140	4,00
9	126,40	111,40	10138009	70	20	45	1,90	10238009	70	25	95	3,79	10338009	70	25	140	5,62
10	138,00	123,29	10138010	80	20	45	2,47	10238010	80	25	95	5,01	10338010	80	25	140	7,45
11	150,00	135,21	10138011	90	25	50	3,27	10238011	90	25	100	6,62	10338011	90	25	150	9,73
12	162,00	147,22	10138012	102	25	50	4,09	10238012	102	25	100	8,28	10338012	102	25	150	12,24
13	174,20	159,18	10138013	114	25	50	5,00	10238013	114	25	100	10,13	10338013	114	25	150	15,02
14	186,20	171,22	10138014	128	25	50	6,09	10238014	128	25	100	12,24	10338014	128	25	150	18,16
15	198,20	183,26	10138015	140	25	50	6,84	10238015	140	25	100	14,08	10338015	140	25	150	21,09
16	210,30	195,30	10138016	140	25	55	8,20	10238016	140	25	100	15,88	10338016	140	25	150	24,25
17	222,30	207,34	10138017	140	25	55	8,87	10238017	150	25	100	17,80	10338017	150	25	150	27,42
18	234,30	219,42	10138018	140	25	55	9,59	10238018	160	25	100	21,08	10338018	160	25	150	32,12
19	246,50	231,49	10138019	140	25	55	10,36	10238019	160	25	100	23,26	10338019	160	25	150	35,74
20	258,60	243,57	10138020	140	25	55	11,16	10238020	160	25	100	25,57	10338020	160	25	150	39,57
21	270,60	255,65	10138021	150	25	60	13,35	10238021	160	25	100	28,01	10338021	160	30	150	42,98
22	282,70	267,73	10138022	150	25	60	14,24	10238022	160	25	100	30,59	10338022	160	30	150	47,25
23	294,80	279,80	10138023	150	25	60	15,18	10238023	160	25	100	33,29	10338023	160	30	150	51,74
24	306,80	291,88	10138024	150	25	60	16,16	10238024	160	25	100	33,13	10338024	160	30	150	56,44
25	319,00	304,00	10138025	150	25	60	17,19	10238025	160	25	100	39,09	10338025	160	30	150	61,37
26	331,00	316,08	10138026	160	30	60	18,25	10238026	160	30	100	42,19	10338026	160	30	150	66,52
27	343,20	328,19	10138027	160	30	60	19,37	10238027	160	30	100	45,41	10338027	160	30	150	71,88
28	355,20	340,27	10138028	160	30	60	20,52	10238028	160	30	100	48,77	10338028	160	30	150	77,46
29	367,30	352,38	10138029	160	30	60	21,72	10238029	160	30	100	52,26					
30	379,50	364,50	10138030	160	30	60	22,97	10238030	160	30	100	55,88	10338030	160	40	150	89,28
31	391,60	376,62	10138031	160	30	60	21,25	10238031	170	30	100	59,19					
32	403,70	388,69	10138032	160	30	60	25,59	10238032	170	30	100	63,07	10338032	170	40	150	101,97
33	415,80	400,81	10138033	160	30	60	26,96	10238033	170	30	100	67,08					
34	427,80	412,93	10138034	160	30	60	28,38	10238034	170	30	100	71,21					
35	440,00	425,04	10138035	160	30	60	29,84	10238035	170	30	100	75,49	10338035	170	40	150	122,64
36	452,00	437,16	10138036	160	30	60	31,34	10238036	170	30	100	79,89					
37	464,20	449,27	10138037	160	30	60	32,90	10238037	170	30	100	84,43					
38	476,20	461,39	10138038	160	30	60	34,49	10238038	170	30	100	89,09	10338038	170	40	150	145,28
39																	
40	500,60	485,62	10138040	160	30	60	37,51	10238040	170	30	100	98,98	10338040	170	40	150	161,46
42	524,70	509,85	10138042	160	30	90	48,52										
45	561,20	546,20	10138045	160	30	90	54,08	10238045	180	40	100	132,81	10338045	200	40	150	209,06
48	597,40	582,55	10138048	160	30	90	60,04										
50	621,70	606,78	10138050	160	30	90	64,24	10238050	180	40	100	162,65	10338050	200	40	150	258,81
57	706,50	691,63	10138057	160	30	100	80,28	10238057	200	40	110	209,91	10338057	220	40	150	337,62
60	742,80	727,97	10138060	160	40	100	87,82										
76	936,90	921,98	10138076	170	40	100	140,54	10238076	220	40	120	373,88	10338076	250	40	150	607,76

MATERIAL **C 45 UNI 7845**
FOR MONOLITHIC CHAIN SPROCKETS

MATERIAL **FE WITH HUB**

CAD drawings available on our site
www.chiaravalli.com

Quantity, availability and prices
on B2B Chiaravalli





1" 3/4 x 1" 1/4

CHAIN SPROCKETS

Tooth radius r_3	44	mm
Radius width \bar{C}	5	mm
Sprockets tooth width B_1	29,4	mm
Sprockets tooth width b_1	28,8	mm
Sprockets tooth width B_2	88,4	mm
Sprockets tooth width B_3	148	mm

CHAIN

Pitch	44,45	mm
Inner width	30,99	mm
Roller \varnothing	27,94	mm

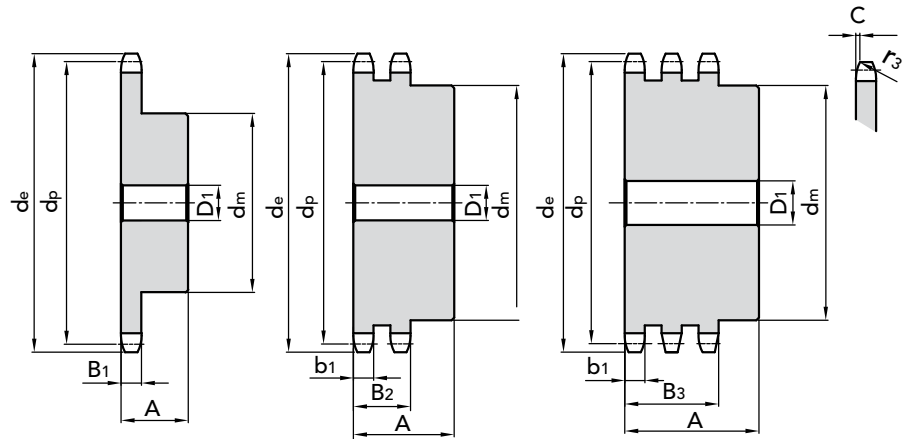

SIMPLEX

DUPLEX

TRIPLEX

Z	d _e	d _p	PART NUMBER	d _m	D ₁	A	kg.	PART NUMBER	d _m	D ₁	A	kg.	PART NUMBER	d _m	D ₁	A	kg.
8	132,00	116,15	10144008	74	25	70	2,86	10244008	74	25	120	4,75	10344008	74	30	180	7,04
9	148,40	129,96	10144009	88	25	70	4,00	10244009	88	25	120	6,66	10344009	88	30	180	9,89
10	162,30	143,85	10144010	100	25	70	5,18	10244010	100	25	120	8,79	10344010	100	30	180	13,10
11	176,30	157,77	10144011	112	25	70	6,51	10244011	112	25	120	11,79	10344011	112	30	180	16,73
12	189,50	171,74	10144012	125	25	70	8,04	10244012	125	25	120	13,91	10344012	125	30	180	20,84
13	204,20	185,75	10144013	130	25	70	8,88	10244013	130	25	120	16,25	10344013	130	30	180	24,70
14	218,20	199,76	10144014	140	25	70	9,79	10244014	140	25	120	18,81	10344014	140	30	180	28,93
15	232,30	213,79	10144015	145	25	70	10,77	10244015	145	25	120	22,64	10344015	145	30	180	34,58
16	246,30	227,84	10144016	160	30	75	14,96	10244016	160	25	120	26,52	10344016	160	30	180	40,44
17	260,00	241,91	10144017	160	30	75	16,09	10244017	160	30	120	29,74	10344017	160	30	180	45,77
18	274,00	255,98	10144018	160	30	75	17,28	10244018	160	30	120	33,17	10344018	160	30	180	51,76
19	289,00	270,06	10144019	160	30	75	18,56	10244019	180	30	120	38,14	10344019	180	30	180	58,07
20	303,00	284,15	10144020	160	30	75	19,90	10244020	180	30	120	42,02	10344020	180	30	180	64,49
21	317,00	298,24	10144021	170	30	75	21,31	10244021	180	30	120	49,10	10344021	180	30	180	71,28
22	331,00	312,34	10144022	170	30	75	22,80	10244022	180	30	120	50,40					
23	345,00	326,44	10144023	170	30	75	24,36	10244023	180	30	120	54,92	10344023	180	30	180	85,94
24	359,00	340,55	10144024	170	30	75	26,00	10244024	180	30	120	59,50					
25	373,00	354,66	10144025	170	30	75	27,70	10244025	180	30	120	64,62	10344025	180	40	180	112,07
26	387,00	368,77	10144026	170	30	75	29,48	10244026	180	30	120	69,28					
27	401,40	382,88	10144027	170	30	75	31,36										
28	416,00	397,00	10144028	170	30	75	33,26	10244028	180	30	120	80,28					
29																	
30	444,00	425,24	10144030	170	30	75	37,33	10244030	180	30	120	92,17	10344030	180	40	180	148,79
31																	
32	472,00	453,49	10144032	180	30	75	43,59										
33																	
34	500,00	481,75	10144034	180	30	75	48,24										
35	514,00	495,88	10144035	180	30	75	50,57	10244035	200	30	120	127,17					
36	529,00	510,01	10144036	180	30	75	53,18										
37																	
38	557,00	538,27	10144038	180	30	75	58,40	10244038	200	30	120	149,9	10344038	200	40	180	244,01
39																	
40	585,00	566,54	10144040	180	30	75	63,92	10244040	200	30	120	167,15	10344040	200	40	180	271,10
45	656,00	637,22	10144045	180	30	90	79,12	10244045	200	30	120	218,10	10344045	200	40	180	352,63
50	726,00	707,91	10144050	180	30	90	96,00	10244050	200	30	120	267,99					
57	825,00	806,90	10144057	180	40	90	125,13	10244057	200	40	120	346,99	10344057	220	40	180	567,76
60	869,00	849,32	10144060	180	40	90	144,00										
76	1.095,0	1.075,62	10144076	200	40	100	215,46	10244076	250	40	130	615,35	10344076	250	40	190	1024,97

MATERIAL **C 45 UNI 7845**
FOR MONOLITHIC CHAIN SPROCKETS

MATERIAL **FE**
FOR CHAIN SPROCKETS WITH WELDED HUB

CAD drawings available on our site
www.chiaravalli.com

Quantity, availability and prices
on B2B Chiaravalli



CHAIN SPROCKETS 1" 3/4 x 1" 1/4 for roller chains in compliance with DIN 8187 - ISO/R 606

2" x 1" 1/4
CHAIN SPROCKETS

Tooth radius r_s	51	mm
Radius width \bar{C}	5	mm
Sprockets tooth width B_1	29,4	mm
Sprockets tooth width b_1	28,8	mm
Sprockets tooth width B_2	87,4	mm
Sprockets tooth width B_3	146	mm

CHAIN

Pitch	50,8	mm
Inner width	30,99	mm
Roller \varnothing	29,21	mm

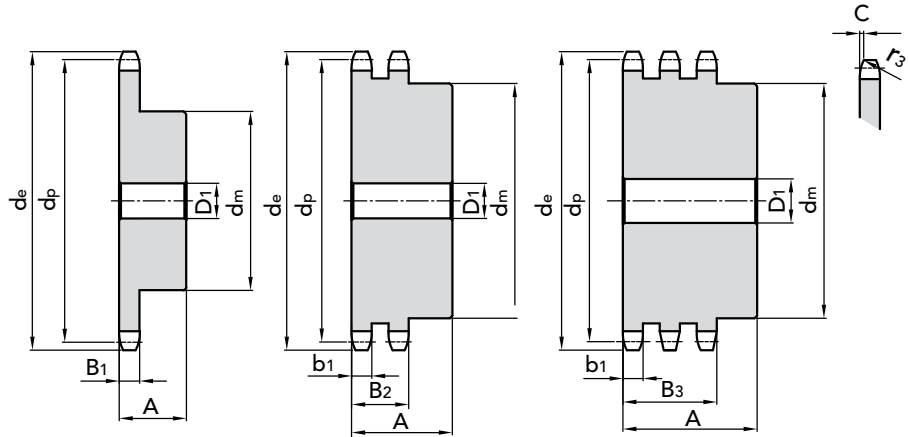

Z	d_e	d_p	SIMPLEX					DUPLEX				TRIPLEX					
			PART NUMBER	d_m	D_1	A	kg.	PART NUMBER	d_m	D_1	A	kg.	PART NUMBER	d_m	D_1	A	kg.
8	153,20	132,69	10150008	82	25	80	4,20	10250008	82	30	120	6,65	10350008	82	30	180	9,90
9	169,00	148,54	10150009	88	25	80	5,78	10250009	88	30	120	9,14	10350009	88	30	180	13,65
10	185,00	164,44	10150010	104	25	80	7,60	10250010	104	30	120	12,01	10350010	104	30	180	17,97
11	200,80	180,34	10150011	120	30	80	9,26	10250011	120	30	120	14,75	10350011	120	30	180	22,22
12	216,80	196,29	10150012	133	30	80	10,91	10250012	133	30	120	17,95	10350012	133	30	180	27,23
13	232,80	212,29	10150013	145	30	80	13,05	10250013	145	30	120	21,68	10350013	145	30	180	32,98
14	248,80	228,29	10150014	160	30	80	14,25	10250014	160	30	120	25,03	10350014	160	30	180	38,50
15	264,80	244,30	10150015	160	30	80	15,53	10250015	160	30	120	29,30	10350015	160	30	180	45,04
16	280,90	260,40	10150016	160	30	90	19,87	10250016	160	30	120	33,21	10350016	160	30	180	51,50
17	296,90	276,40	10150017	170	30	90	21,35	10250017	180	30	120	38,76	10350017	180	30	180	61,45
18	313,00	292,55	10150018	170	30	90	22,92	10250018	180	30	120	43,24	10350018	180	30	180	68,85
19	329,10	308,66	10150019	170	30	90	24,53	10250019	200	30	120	49,52	10350019	200	30	180	76,73
20	345,20	324,71	10150020	180	30	90	28,50	10250020	200	30	120	54,56	10350020	200	30	180	85,07
21	361,30	340,82	10150021	180	30	90	30,36	10250021	200	30	120	59,87	10350021	200	40	180	93,89
22	377,50	356,98	10150022	180	30	90	32,31	10250022	200	30	120	65,47					
23	393,60	373,08	10150023	180	30	90	34,36	10250023	200	30	120	71,35	10350023	200	40	180	112,93
24	409,70	389,18	10150024	180	30	90	36,50	10250024	200	30	120	77,52					
25	425,80	405,33	10150025	180	30	90	38,74	10250025	200	30	120	83,66	10350025	200	40	180	133,86
26	441,90	421,44	10150026	180	30	90	41,07	10250026	200	30	120	90,69					
27	458,10	437,69	10150027	180	30	90	46,01	10250027	200	30	120	98,50					
28	474,20	453,69	10150028	180	30	90	46,01	10250028	200	30	120	104,99					
29																	
30	506,50	486,00	10150030	180	30	90	51,34	10250030	200	30	120	120,41	10350030	200	40	180	194,42
32	538,80	518,28	10150032	180	30	90	59,89										
35	589,50	566,72	10150035	180	30	90	69,16	10250035	200	30	120	163,85					
38	635,50	615,14	10150038	180	30	90	79,28	10250038	200	40	120	193,33	10350038	200	40	180	316,22
40	670,30	647,49	10150040	180	30	90	86,50	10250040	200	40	120	214,39					
45	751,00	728,26	10150045	180	40	100	118,87	10250045	200	40	120	282,32	10350045	200	40	180	456,64
50	831,80	809,04	10150050	180	40	100	140,96	10250050	200	40	120	346,95	10350050	200	40	180	564,27
57	945,00	922,17	10150057	180	40	100	175,86	10250057	220	40	120	449,27	10350057	250	40	180	734,72
60	993,40	970,63	10150060	180	40	100	192,24										
76	1.252,0	1.229,28	10150076	200	40	110	294,00	10250076	250	40	130	796,60	10350076	250	40	190	1319,64

MATERIAL **C 45 UNI 7845**
FOR MONOLITHIC CHAIN SPROCKETS

MATERIAL **FE**
FOR CHAIN SPROCKETS WITH WELDED HUB

CAD drawings available on our site
www.chiaravalli.com

Quantity, availability and prices
on B2B Chiaravalli





pitch 3/8" x 3/16"

CHAIN SPROCKETS

Tooth radius r_3	10	mm
Radius width \check{C}	1,2	mm
Sprockets tooth width B_1	4,4	mm
Sprockets tooth width b_1	4,3	mm
Sprockets tooth width B_2	14,4	mm

CHAIN

Pitch	9,525	mm
Inner width	4,77	mm
Roller \varnothing	5,08	mm

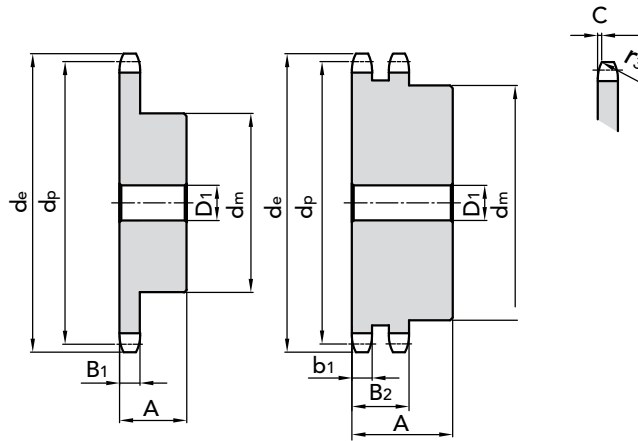

SIMPLEX

DUPLEX

Z	d _e	d _p	PART NUMBER	d _m	D ₁	A	kg.	PART NUMBER	d _m	D ₁	A	kg.
8												
9	31,50	27,85	11103009	18	8	20	0,05					
10	35,70	30,82	11103010	20	8	22	0,05	11203010	20	8	22	0,15
11	38,69	33,80	11103011	22	8	25	0,08	11203011	22	10	25	0,15
12	41,68	36,80	11103012	25	8	25	0,10					
13	44,68	39,80	11103013	28	10	25	0,12	11203013	28	10	25	0,16
14	47,68	42,80	11103014	31	10	25	0,15	11203014	31	10	25	0,19
15	50,69	45,81	11103015	34	10	25	0,19	11203015	34	10	25	0,23
16	53,70	48,82	11103016	37	10	28	0,24	11203016	37	12	30	0,27
17	56,72	51,83	11103017	38	10	28	0,28	11203017	40	12	30	0,31
18	59,73	54,85	11103018	38	10	28	0,32	11203018	43	12	30	0,36
19	62,75	57,87	11103019	46	10	28	0,36	11203019	46	12	30	0,42
20	65,77	60,89	11103020	46	10	28	0,38	11203020	49	12	30	0,42
21	68,79	63,91	11103021	46	10	28	0,41	11203021	52	12	30	0,51
22	71,81	66,93	11103022	52	12	28	0,45	11203022	55	12	30	0,57
23	74,83	69,95	11103023	52	12	28	0,49	11203023	58	12	30	0,64
24	77,85	72,97	11103024	52	12	28	0,54	11203024	61	12	30	0,71
25	80,88	76,00	11103025	58	12	28	0,60	11203025	64	12	30	0,78
26	83,90	79,02	11103026	58	12	28	0,66	11203026	67	12	30	0,78
27	86,93	82,04	11103027	58	12	28	0,67	11203027	70	12	30	0,94
28	89,95	85,07	11103028	60	12	28	0,68	11203028	73	12	30	1,02
30	96,00	91,12	11103030	60	12	28	0,71					
31	97,9	94,15	11103031	65	14	30	0,87	11203031	80	16	30	1,02
32	100,9	97,17	11103032	65	14	30	0,86	11203032	80	16	30	1,31
33	103,9	100,20	11103033	65	14	30	1,13					
34	106,9	103,23						11203034	80	16	30	1,42
35	110,0	106,26	11103035	65	14	30	0,94	11203035	80	16	30	1,48
36	114,17	109,29	11103036	70	16	30	1,05					
37	116,0	112,32	11103037	70	16	30	1,09					
38	119,0	115,34	11103038	70	16	30	1,08	11203038	90	16	30	1,48
39	122,1	118,37	11103039	70	16	30	1,10	11203039	90	16	30	1,48
40												

MATERIAL C 45 UNI 7845

CAD drawings available on our site
www.chiaravalli.com

Quantity, availability and prices
 on B2B Chiaravalli



CHAIN SPROCKETS ASA 35 pitch 3/8" x 3/16" for roller chains in compliance with DIN 8188 - ISO/R 606 - ANSI B 29.1



pitch 1/2" x 5/16"

CHAIN SPROCKETS

Tooth radius r_3	13,5 mm
Radius width \bar{C}	1,6 mm
Sprockets tooth width B_1	7,4 mm
Sprockets tooth width b_1	7,2 mm
Sprockets tooth width B_2	21,6 mm
Sprockets tooth width B_3	36 mm

CHAIN

Pitch	12,7 mm
Inner width	7,94 mm
Roller \emptyset	7,94 mm

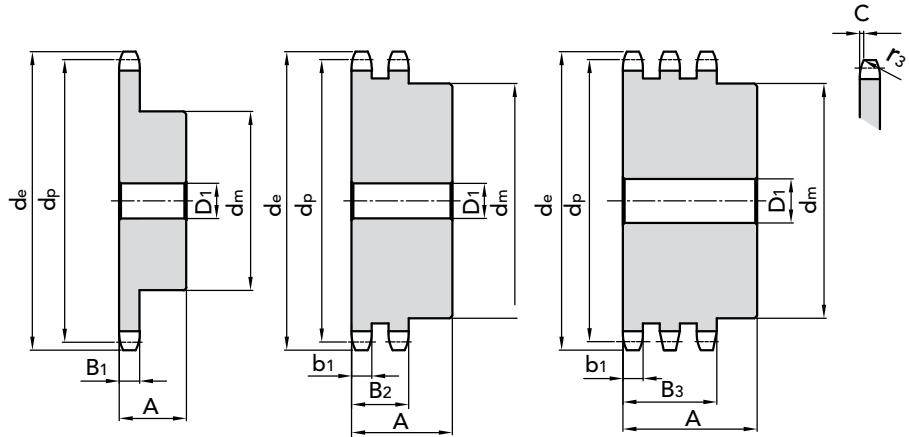

Z	d_e	d_p	SIMPLEX				DUPLEX				TRIPLEX							
			PART NUMBER	d_m	D_1	A	kg.	PART NUMBER	d_m	D_1	A	kg.	PART NUMBER	d_m	D_1	A	kg.	
8	39,30	33,18	11104008	26	10	25	0,10											
10	47,66	41,10	11104010	29	10	25	0,12	11204010	28	10	32	0,19	11304010	28	14	50	0,24	
11	51,64	45,08	11104011	35	10	28	0,14	11204011	32	12	35	0,29						
12	55,63	49,07	11104012	35	10	28	0,20	11204012	35	12	35	0,35	11304012	35	14	50	0,39	
13	59,63	53,07	11104013	35	10	28	0,26	11204013	38	12	35	0,43	11304013	38	14	50	0,49	
14	63,63	57,07	11104014	46	10	28	0,32	11204014	42	12	35	0,52	11304014	42	14	50	0,60	
15	67,64	61,08	11104015	48	10	28	0,38	11204015	46	12	35	0,62	11304015	46	14	50	0,72	
16	71,66	65,10	11104016	48	10	28	0,45	11204016	50	14	35	0,73	11304016	50	16	50	0,85	
17	75,68	69,12	11104017	48	10	28	0,50	11204017	54	14	35	0,83	11304017	54	16	50	0,99	
18	79,70	73,14	11104018	60	12	28	0,58	11204018	58	14	35	0,97	11304018	58	16	50	1,14	
19	83,72	77,16	11104019	60	12	28	0,67	11204019	62	14	35	1,12	11304019	62	16	50	1,30	
20	87,74	81,18	11104020	65	12	28	0,77	11204020	66	14	35	1,28	11304020	66	16	50	1,47	
21	91,77	85,21	11104021	65	12	28	0,84	11204021	70	16	40	1,37	11304021	70	20	55	1,79	
22	95,80	89,24	11104022	65	12	28	0,91	11204022	70	16	40	1,46	11304022	70	20	55	1,93	
23	99,83	93,27	11104023	70	12	28	0,94	11204023	70	16	40	1,63	11304023	70	20	55	2,08	
24	103,86	97,30	11104024	70	14	28	0,97	11204024	75	16	40	1,82	11304024	75	20	55	2,32	
25	107,89	101,33	11104025	70	14	28	1,01	11204025	80	16	40	2,01	11304025	80	20	55	2,57	
26	111,92	105,36	11104026	70	14	28	1,09	11204026	85	20	40	2,12	11304026	85	20	55	2,79	
27	115,96	109,40	11104027	70	16	30	1,13	11204027	85	20	40	2,33	11304027	85	20	55	2,96	
28	119,99	113,43	11104028	70	16	30	1,16	11204028	90	20	40	2,79	11304028	90	20	55	3,25	
29																		
30	128,06	121,50	11104030	80	16	30	1,46	11204030	100	20	40	3,25						
31								11204031	100	20	40	3,33						
32	136,13	129,57	11104032	80	16	30	1,78											
33								11204033	100	20	40	3,40	11304033	110	20	55	4,74	
34								11204034	100	20	40	3,50						
35	148,24	141,68	11104035	90	16	30	1,92	11204035	100	20	40	3,60						
36	152,28	145,72	11104036	90	16	30	2,21											
37								11204037	100	20	40	3,69						
38	160,35	153,79	11104038	90	16	35	2,32	11204038	100	20	40	3,84	11304038	120	25	55	6,14	
39								11204039	100	20	40	4,00						
40	168,43	161,87	11104040	90	16	35	2,43						11304040	120	25	55	6,66	

MATERIAL C 45 UNI 7845

 CAD drawings available on our site
www.chiaravalli.com

 Quantity, availability and prices
 on B2B Chiaravalli





pitch 5/8" x 3/8"

CHAIN SPROCKETS

Tooth radius r_3	17	mm
Radius width \bar{C}	2	mm
Sprockets tooth width B_1	9	mm
Sprockets tooth width b_1	8,8	mm
Sprockets tooth width B_2	26,9	mm
Sprockets tooth width B_3	45	mm

CHAIN

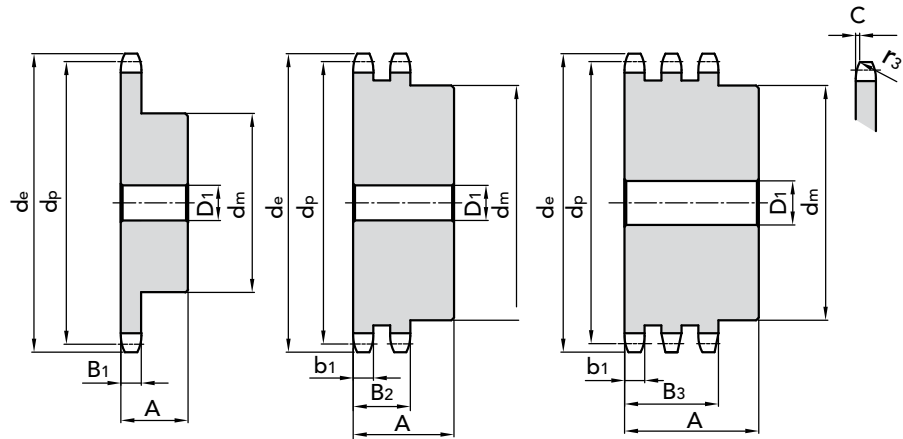
Pitch	15,875	mm
Inner width	9,52	mm
Roller \varnothing	10,16	mm



SIMPLEX

DUPLEX

TRIPLEX

Z	d _e	d _p	PART NUMBER	d _m	D ₁	A	kg.	PART NUMBER	d _m	D ₁	A	kg.	PART NUMBER	d _m	D ₁	A	kg.
8	47,00	41,48	10115008	25	10	25	0,12										
9	52,60	46,42	10115009	30	10	25	0,16										
10	57,50	51,37	10115010	35	10	25	0,22										
11	63,00	56,34	10115011	37	12	30	0,29										
12	68,00	61,34	10115012	42	12	30	0,37						11305012	44	16	55	0,54
13	73,00	66,32	10115013	47	12	30	0,46	11205013	49	14	40	0,67	11305013	49	16	55	0,67
14	78,00	71,34	10115014	52	12	30	0,56	11205014	54	14	40	0,82	11305014	54	16	55	0,82
15	83,00	76,36	10115015	57	12	30	0,67	11205015	59	14	40	0,97	11305015	59	16	55	0,97
16	88,00	81,37	10115016	60	12	30	0,76	11205016	64	16	45	1,25	11305016	64	16	60	1,25
17	93,00	86,39	10115017	60	12	30	0,88	11205017	69	16	45	1,45	11305017	69	16	60	1,45
18	98,00	91,42	10115018	70	14	30	1,01	11205018	74	16	45	1,56	11305018	74	16	60	1,56
19	103,30	96,45	10115019	70	14	30	1,15	11205019	79	16	45	1,67	11305019	79	16	60	1,67
20	108,40	101,49	10115020	75	14	30	1,21	11205020	84	16	45	2,14	11305020	84	16	60	2,14
21	113,40	106,52	10115021	75	16	30	1,35	11205021	85	16	45	2,27	11305021	85	20	60	2,27
22	118,00	111,55	10115022	80	16	30	1,41	11205022	90	16	45	2,54	11305022	90	20	60	2,54
23	123,40	116,58	10115023	80	16	30	1,47	11205023	95	16	45	2,81	11305023	95	20	60	2,81
24	128,30	121,62	10115024	80	16	30	1,54	11205024	100	16	45	3,11	11305024	100	20	60	3,11
25	134,00	126,66	10115025	80	16	30	1,60	11205025	105	16	45	3,14	11305025	105	20	60	3,14
26	139,00	131,70	10115026	85	20	35	1,96						11305026	110	20	60	3,74
27	144,00	136,75	10115027	85	20	35	2,04						11305027	110	20	60	3,94
28	148,70	141,78	10115028	90	20	35	2,25						11305028	115	20	60	4,28
29	153,80	146,83	10115029	90	20	35	2,33										
30	158,80	151,87	10115030	90	20	35	2,41										
31	163,90	156,92	10115031	95	20	35	2,64										
32	168,90	161,95	10115032	95	20	35	2,73										
33	174,50	167,00	10115033	95	20	35	2,82										
34	179,00	172,05	10115034	95	20	35	2,92										
35	184,10	177,10	10115035	95	20	35	3,01										
36	189,10	182,15	10115036	100	20	35	3,27										
37	194,20	187,20	10115037	100	20	35	3,37										
38	199,20	192,24	10115038	100	20	35	3,47										
39	104,20	197,29	10115039	100	20	35	3,58										
40	209,30	202,34	10115040	100	20	35	3,69										

MATERIAL **C 45 UNI 7845**

Simple sprockets correspond to 5/8 pitch ISO sprockets

CAD drawings available on our site
www.chiaravalli.com

Quantity, availability and prices
 on B2B Chiaravalli



CHAIN SPROCKETS ASA 50 pitch 5/8" x 3/8" for roller chains in compliance with DIN 8188 - ISO/R 606 - ANSI B 29.1



CHAIN SPROCKETS ASA 60 pitch 3/4" x 1/2" for roller chains in compliance with DIN 8188 - ISO/R 606 - ANSI B 29.1

pitch 3/4" x 1/2"

CHAIN SPROCKETS

Tooth radius r_3	20	mm
Radius width \check{C}	2,4	mm
Sprockets tooth width B_1	12	mm
Sprockets tooth width b_1	11,8	mm
Sprockets tooth width B_2	34,6	mm
Sprockets tooth width B_3	57,4	mm

CHAIN

Pitch	19,05	mm
Inner width	12,7	mm
Roller \varnothing	11,91	mm

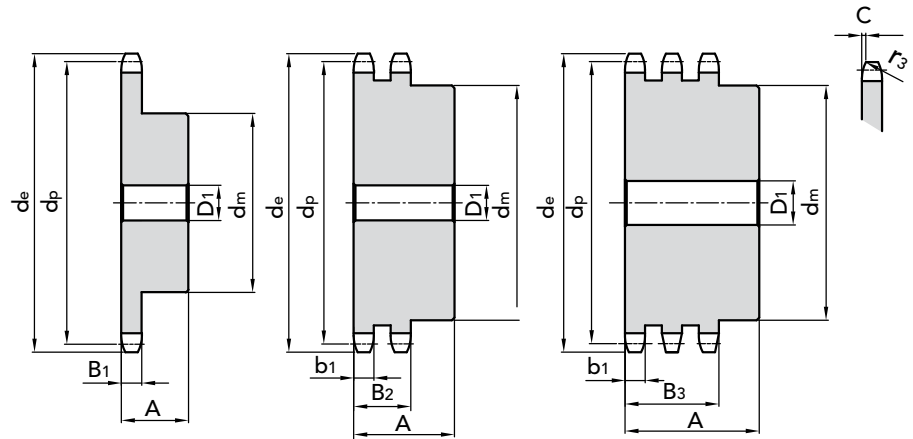

Z	d_e	d_p	SIMPLEX					DUPLEX				TRIPLEX					
			PART NUMBER	d_m	D_1	A	kg.	PART NUMBER	d_m	D_1	A	kg.	PART NUMBER	d_m	D_1	A	kg.
10	71,54	61,64	11106010	42	12	30	0,38	11206010	42	12	45	0,58	11306010	42	16	65	0,86
11	77,51	67,61	11106011	45	12	30	0,50	11206011	47	16	50	0,80					
12	83,49	73,61	11106012	45	12	30	0,64	11206012	53	16	50	1,01	11306012	53	20	70	1,47
13	89,49	79,59	11106013	60	14	35	0,80	11206013	59	16	50	1,24	11306013	59	20	70	1,78
14	95,50	85,61	11106014	60	14	35	0,97	11206014	65	16	50	1,45	11306014	65	20	70	2,16
15	101,52	91,63	11106015	60	14	35	1,16	11206015	71	16	50	1,73	11306015	71	20	70	2,52
16	107,54	97,65	11106016	75	16	35	1,34	11206016	77	20	50	2,03	11306016	77	20	70	2,93
17	113,56	103,67	11106017	75	16	35	1,53	11206017	83	20	50	2,35	11306017	83	20	70	3,44
18	119,59	109,71	11106018	75	16	35	1,61	11206018	89	20	50	2,70	11306018	89	20	70	3,91
19	125,63	115,75	11106019	80	16	35	1,70	11206019	95	20	50	3,06	11306019	95	20	70	4,43
20	131,67	121,78	11106020	80	16	35	1,84	11206020	100	20	50	3,45	11306020	100	20	70	4,96
21	137,71	127,82	11106021	80	16	35	2,35	11206021	100	20	50	3,69	11306021	100	20	70	5,41
22	143,75	133,86	11106022	90	20	40	2,45	11206022	100	20	50	3,96	11306022	100	20	70	59,7
23	149,79	139,90	11106023	90	20	40	2,56	11206023	110	20	50	4,50	11306023	110	20	70	6,64
24	155,84	145,94	11106024	90	20	40	2,67	11206024	110	20	50	4,81	11306024	110	20	70	7,21
25	161,88	152,00	11106025	90	20	40	2,79	11206025	120	20	50	5,40	11306025	120	20	70	7,97
26	167,93	158,04	11106026	90	20	40	3,08	11206026	120	20	50	5,73					
27	173,98	164,09	11106027	90	20	40	3,21	11206027	120	20	50	6,05					
28	180,03	170,13	11106028	95	20	40	3,34	11206028	120	20	50	6,43					
30	192,14	182,25	11106030	95	20	40	3,62	11206030	120	20	50	7,18					

MATERIAL C 45 UNI 7845

 CAD drawings available on our site
www.chiaravalli.com

 Quantity, availability and prices
 on B2B Chiaravalli





pitch 1" x 5/8"

CHAIN SPROCKETS

Tooth radius r_3	27	mm
Radius width \bar{C}	3,2	mm
Sprockets tooth width B_1	15	mm
Sprockets tooth width b_1	14,7	mm
Sprockets tooth width B_2	44	mm
Sprockets tooth width B_3	73,3	mm

CHAIN

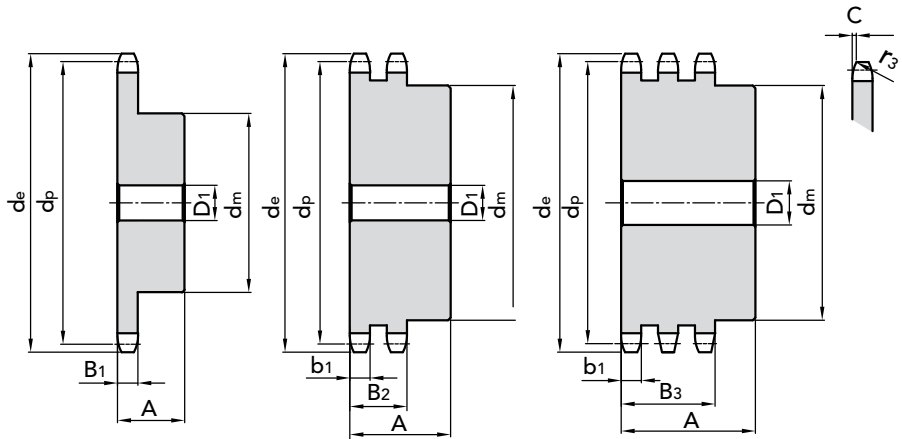
Pitch	25,4	mm
Inner width	15,88	mm
Roller \varnothing	15,88	mm



SIMPLEX

DUPLEX

TRIPLEX

Z	d _e	d _p	PART NUMBER	d _m	D ₁	A	kg.	PART NUMBER	d _m	D ₁	A	kg.	PART NUMBER	d _m	D ₁	A	kg.	
8																		
9																		
10	95,32	82,79	11108010	55	16	35	0,82	11208010	56	20	65	1,52						
11	103,28	90,14	11108011	61	16	40	1,13											
12	111,26	98,14	11108012	69	16	40	1,42	11208012	72	20	70	2,60	11308012	72	25	100	3,62	
13	119,26	106,12	11108013	78	16	40	1,77	11208013	78	20	70	3,22	11308013	78	25	100	4,45	
14	127,27	114,15	11108014	84	16	40	2,07	11208014	86	20	70	3,82	11308014	86	25	100	5,37	
15	135,29	122,17	11108015	92	16	40	2,46	11208015	94	20	70	4,51	11308015	94	25	100	6,37	
16	143,32	130,20	11108016	100	20	45	3,13	11208016	102	20	70	5,17	11308016	102	30	100	7,45	
17	151,35	138,22	11108017	100	20	45	3,34	11208017	110	20	70	5,97	11308017	110	30	100	8,60	
18	159,39	146,28	11108018	100	20	45	3,55	11208018	118	20	70	6,84	11308018	118	30	100	9,84	
19	167,44	154,33	11108019	100	20	45	3,78	11208019	126	20	70	7,75	11308019	126	30	100	11,16	
20	175,49	162,38	11108020	100	20	45	4,02	11208020	130	20	70	8,43	11308020	130	30	100	12,36	
21	183,54	170,43	11108021	110	20	50	5,01	11208021	130	25	70	9,24						
22	191,60	178,48	11108022	110	20	50	5,26											
23	199,66	186,53	11108023	110	20	50	5,56											
24	207,72	194,59	11108024	110	20	50	5,85											
25	215,78	202,66	11108025	110	20	50	6,16	11208025	130	25	70	12,52						
26	223,84	210,72	11108026	120	20	50	6,96											
27	231,91	218,79	11108027	120	20	50	7,29											
28	239,98	226,85	11108028	120	20	50	7,64											
29																		
30	256,12	243,00	11108030	120	20	50	7,96											

MATERIAL C 45 UNI 7845

CAD drawings available on our site
www.chiaravalli.com

Quantity, availability and prices
 on B2B Chiaravalli



CHAIN SPROCKETS ASA 80 pitch 1" x 5/8" for roller chains in compliance with DIN 8188 - ISO/R 606 - ANSI B 29.1



CHAIN SPROCKETS ASA 100 pitch 1" 1/4 x 3/4" for roller chains in compliance with DIN 8188 - ISO/R 606 - ANSI B 29.1

pitch 1" 1/4 x 3/4"

CHAIN SPROCKETS

Tooth radius r_3	33,5	mm
Radius width \check{C}	4	mm
Sprockets tooth width B_1	18	mm
Sprockets tooth width b_1	17,7	mm
Sprockets tooth width B_2	53,5	mm
Sprockets tooth width B_3	89,2	mm

CHAIN

Pitch	31,75	mm
Inner width	19,05	mm
Roller \varnothing	19,05	mm

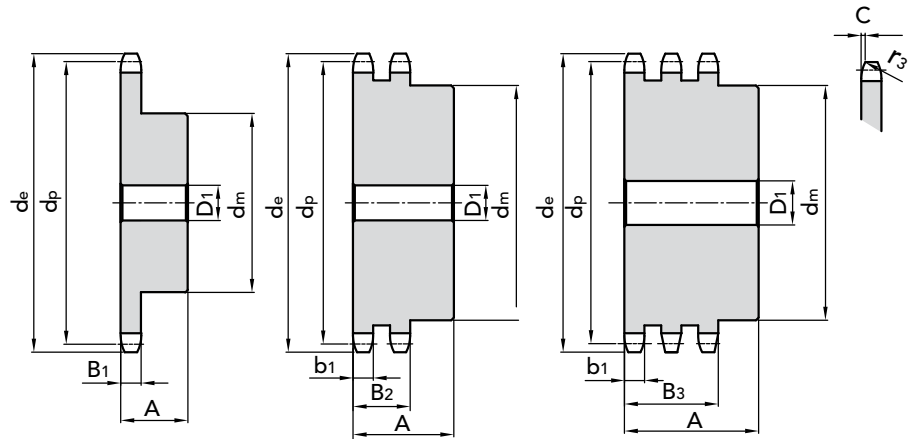

Z	d_e	d_p	SIMPLEX				DUPLEX				TRIPLEX						
			PART NUMBER	d_m	D_1	A	kg.	PART NUMBER	d_m	D_1	A	kg.	PART NUMBER	d_m	D_1	A	kg.
8	98,10	82,96	11110008	53	20	40	0,85										
9	108,00	92,84	11110009	63	20	40	1,18										
10	117,90	102,74	11110010	70	20	40	1,57										
11	127,80	112,68	11110011	77	20	45	2,04	11210011	80	25	80	3,72					
12	137,80	122,68	11110012	88	20	45	2,58	11210012	90	20	80	4,66					
13	147,80	132,65	11110013	98	20	45	3,15	11210013	100	20	80	5,70					
14	157,80	142,68	11110014	108	20	45	3,78	11210014	110	20	80	6,84	11310014	110	30	115	9,71
15	167,90	152,72	11110015	118	20	45	4,47	11210015	120	20	80	8,08					
16	177,90	162,75	11110016	120	25	50	5,25	11210016	120	25	80	8,90					
17	187,90	172,78	11110017	120	25	50	5,61	11210017	120	25	80	9,92	11310017	420	30	115	14,60
18	198,00	182,85	11110018	120	25	50	5,99										
19	208,10	192,91	11110019	120	25	50	6,40										
20	218,10	202,95	11110020	120	25	50	6,82										
21	228,20	213,04	11110021	140	25	55	8,79										
22	238,30	223,11	11110022	140	25	55	9,27										
23	248,30	233,17	11110023	140	25	55	9,77										
24	258,40	243,23	11110024	140	25	55	10,30										
25	268,50	253,33	11110025	140	25	55	10,85										

MATERIAL C 45 UNI 7845

 CAD drawings available on our site
www.chiaravalli.com

 Quantity, availability and prices
 on B2B Chiaravalli





pitch 1" 1/2 x 1"

CHAIN SPROCKETS

Tooth radius r_3	40,5	mm
Radius width \bar{C}	4,8	mm
Sprockets tooth width B_1	24,1	mm
Sprockets tooth width b_1	23,6	mm
Sprockets tooth width B_2	69	mm

CHAIN

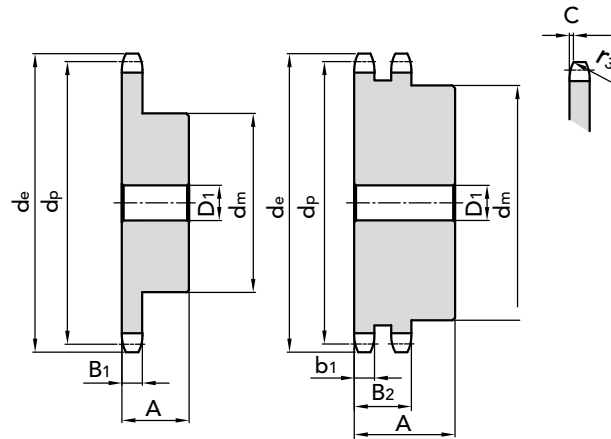
Pitch	38,1	mm
Inner width	25,4	mm
Roller \varnothing	22,22	mm



SIMPLEX

DUPLEX

Z	d_e	d_p	PART NUMBER	d_m	D_1	A	kg.	PART NUMBER	d_m	D_1	A	kg.
8	119,04	99,55	11112008	58	20	45	2,05					
9	130,88	111,40	11112009	70	20	45	2,67					
10	142,77	123,29	11112010	80	20	45	3,45					
11	154,71	135,21	11112011	90	25	50	4,26	11212011	90	25	100	6,62
12	165,00	147,22	11112012	102	25	50	5,22	11212012	102	25	100	8,28
13	178,68	159,18	11112013	114	25	50	6,29	11212013	114	25	100	10,13
14	190,70	171,22	11112014	128	25	50	7,05	11212014	128	25	100	12,24
15	202,73	183,26	11112015	140	25	50	8,12	11212015	140	25	100	14,08
17												
18												
19	245,5	231,49	11112019	136	25	55	10,05					

MATERIAL C 45 UNI 7845

On demand we can manufacture ASA sprockets and pitches not shown on this catalogue.

Quantity, availability and prices on B2B Chiaravalli



CHAIN SPROCKETS ASA 120 pitch 1"1/2 x 1" for roller chains in compliance with DIN 8188 - ISO/R 606 - ANSI B 29.1



MATERIAL **STAINLESS STEEL**
AISI 304 L

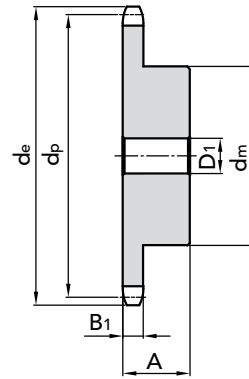

PITCH	Z	de	PART NUMBER	dp	dm	D1	A	B ₁	Kg
3/8" x 7/32"	12	40,00	14109012	36,80	25,00	8,00	25,00	5,3	0,12
	13	43,00	14109013	39,79	28,00	10,00	25,00	5,3	0,13
	15	49,00	14109015	45,81	34,00	10,00	25,00	5,3	0,19
	16	52,30	14109016	48,82	37,00	10,00	28,00	5,3	0,24
	17	55,30	14109017	51,83	40,00	10,00	28,00	5,3	0,28
	18	58,30	14109018	54,85	43,00	10,00	28,00	5,3	0,33
	19	61,30	14109019	57,87	45,00	10,00	28,00	5,3	0,36
	20	64,30	14109020	60,89	46,00	10,00	28,00	5,3	0,39
	21	68,00	14109021	63,91	48,00	12,00	28,00	5,3	0,42
	23	73,50	14109023	69,65	52,00	12,00	28,00	5,3	0,50
1/2" x 5/16"	25	80,00	14109025	76,00	57,00	12,00	28,00	5,3	0,60
	30	94,70	14109030	91,12	60,00	12,00	30,00	5,3	0,72
	12	53,00	14112012	49,07	33,00	10,00	28,00	7,2	0,21
	13	57,90	14112013	53,06	37,00	10,00	28,00	7,2	0,26
	15	65,90	14112015	61,09	45,00	10,00	28,00	7,2	0,38
	16	69,90	14112016	65,10	50,00	12,00	28,00	7,2	0,46
	17	74,00	14112017	69,11	52,00	12,00	28,00	7,2	0,51
	18	78,00	14112018	73,14	56,00	12,00	28,00	7,2	0,59
	19	82,00	14112019	77,16	60,00	12,00	28,00	7,2	0,67
	20	86,00	14112020	81,19	64,00	12,00	28,00	7,2	0,76
5/8" x 3/8"	21	90,01	14112021	85,22	68,00	14,00	28,00	7,2	0,85
	23	98,01	14112023	93,27	70,00	14,00	28,00	7,2	0,94
	25	106,20	14112025	101,33	70,00	14,00	28,00	7,2	1,01
	30	126,30	14112030	121,50	80,00	16,00	30,00	7,2	1,46
	12	68,00	14115012	61,34	42,00	12,00	30,00	9,1	0,37
	13	73,00	14115013	66,32	47,00	12,00	30,00	9,1	0,46
	15	83,00	14115015	76,36	57,00	12,00	30,00	9,1	0,67
	16	88,00	14115016	81,37	60,00	12,00	30,00	9,1	0,76
	17	93,00	14115017	86,39	60,00	12,00	30,00	9,1	0,88
	18	98,30	14115018	91,42	70,00	12,00	30,00	9,1	1,01
19	103,30	14115019	96,45	70,00	14,00	30,00	9,1	1,15	
20	108,40	14115020	101,49	75,00	14,00	30,00	9,1	1,21	
21	113,40	14115021	106,52	80,00	16,00	30,00	9,1	1,35	
23	123,40	14115023	116,58	80,00	16,00	30,00	9,1	1,47	
25	134,00	14115025	126,66	80,00	16,00	30,00	9,1	1,60	
30	158,80	14115030	151,87	90,00	20,00	35,00	9,1	2,41	

MATERIAL **STAINLESS STEEL**
AISI 304 L

CAD drawings available on our site
www.chiaravalli.com

Quantity, availability and prices
on B2B Chiaravalli





STAINLESS STEEL CHAIN SPROCKETS

MATERIAL **STAINLESS STEEL**
AISI 304 L

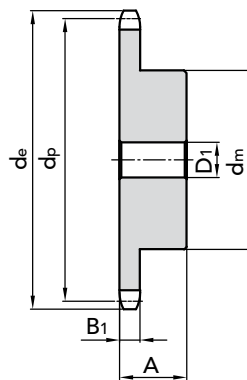

PITCH	Z	de	PART NUMBER	dp	dm	D1	A	B ₁	Kg
3/4" x 7/16"	12	81,50	14119012	73,61	52,00	14,00	35,00	11,1	0,65
	13	87,50	14119013	79,59	58,00	16,00	35,00	11,1	0,80
	15	99,80	14119015	91,63	70,00	16,00	35,00	11,1	1,16
	16	105,50	14119016	97,65	75,00	16,00	35,00	11,1	1,34
	17	111,50	14119017	103,67	80,00	16,00	35,00	11,1	1,53
	18	118,00	14119018	109,71	80,00	16,00	35,00	11,1	1,61
	19	124,20	14119019	115,75	80,00	16,00	35,00	11,1	1,70
	20	129,70	14119020	121,78	80,00	16,00	35,00	11,1	1,80
	21	136,00	14119021	127,82	90,00	20,00	40,00	11,1	2,35
	23	149,00	14119023	139,90	90,00	20,00	40,00	11,1	2,56
1" x 17,02	25	160,00	14119025	152,00	90,00	20,00	40,00	11,1	2,80
	30	189,78	14119030	182,25	95,00	20,00	40,00	11,1	2,63
	12	109,00	14125012	98,14	69,00	16,00	40,00	16,2	1,43
	13	117,00	14125013	106,12	78,00	16,00	40,00	16,2	1,77
	15	133,00	14125015	122,17	92,00	16,00	40,00	16,2	2,46
	16	141,00	14125016	130,20	100,00	19,00	45,00	16,2	3,14
	17	149,00	14125017	138,22	100,00	20,00	45,00	16,2	3,34
	18	157,00	14125018	146,28	100,00	20,00	45,00	16,2	3,56
	19	165,20	14125019	154,33	100,00	20,00	45,00	16,2	3,78
	20	173,50	14125020	162,38	100,00	20,00	45,00	16,2	4,03
	21	181,20	14125021	170,43	110,00	20,00	50,00	16,2	5,01
	23	197,50	14125023	182,25	110,00	20,00	50,00	16,2	5,56
	25	213,50	14125025	202,66	110,00	20,00	50,00	16,2	6,16
	30	254,00	14125030	243,00	120,00	20,00	55,00	16,2	8,38

MATERIAL **STAINLESS STEEL**
AISI 304 L



CAD drawings available on our site
www.chiaravalli.com

Quantity, availability and prices
on B2B Chiaravalli

STAINLESS STEELCHAIN SPROCKETS for roller chains in compliance with DIN 8187 - ISO/R 606

SIMPLEX CHAIN SPROCKETS HARDENED

HRC 45 ÷ 53

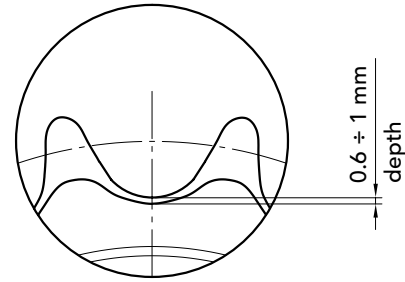
SIMPLEX CHAIN SPROCKETS HARDENED HRC 45 ÷ 53
MATERIAL C 45 UNI 7845

PITCH	Z	de	PART NUMBER	dp	dm	D1	A	Kg
3/8" x 7/32"	13	43,00	15109013	39,79	28,00	10,00	25,00	0,13
	14	46,50	15109014	42,80	31,00	10,00	25,00	0,16
	15	49,30	15109015	45,81	34,00	10,00	25,00	0,18
	16	52,30	15109016	48,82	37,00	10,00	28,00	0,24
	17	55,30	15109017	51,83	40,00	10,00	28,00	0,28
	18	59,30	15109018	54,85	43,00	10,00	28,00	0,33
	19	61,30	15109019	57,87	45,00	10,00	28,00	0,36
	20	64,30	15109020	60,89	46,00	10,00	28,00	0,39
	21	68,00	15109021	63,91	48,00	12,00	28,00	0,42
	23	73,50	15109023	69,95	52,00	12,00	28,00	0,50
	25	80,00	15109025	76,00	57,00	12,00	28,00	0,60
1/2" x 5/16"	27	86,00	15109027	82,05	60,00	12,00	28,00	0,65
	30	94,70	15109030	91,12	60,00	12,00	30,00	0,72
	13	57,40	15112013	53,60	37,00	10,00	28,00	0,26
	14	61,80	15112014	57,07	41,00	10,00	28,00	0,32
	15	65,90	15112015	61,09	45,00	10,00	28,00	0,38
	16	69,90	15112016	65,10	50,00	12,00	28,00	0,46
	17	74,00	15112017	69,11	52,00	12,00	28,00	0,51
	18	78,00	15112018	73,14	56,00	12,00	28,00	0,59
	19	82,00	15112019	77,16	60,00	12,00	28,00	0,67
	20	86,00	15112020	81,19	64,00	12,00	28,00	0,76
	21	90,10	15112021	85,22	68,00	14,00	28,00	0,85
5/8" x 3/8"	23	98,10	15112023	93,27	70,00	14,00	28,00	0,91
	25	106,20	15112025	101,33	70,00	14,00	28,00	1,01
	27	114,00	15112027	109,40	70,00	16,00	30,00	1,26
	30	126,30	15112030	121,50	80,00	16,00	30,00	1,46
	13	73,00	15115013	66,32	47,00	12,00	30,00	0,46
	14	78,20	15115014	71,34	52,00	12,00	30,00	0,56
	15	83,00	15115015	76,36	57,00	12,00	30,00	0,67
	16	88,00	15115016	81,37	60,00	12,00	30,00	0,76
	17	93,00	15115017	86,39	60,00	12,00	30,00	0,88
	18	98,30	15115018	91,42	70,00	12,00	30,00	1,01
	19	103,30	15115019	96,45	70,00	14,00	30,00	1,15
20	108,40	15115020	101,49	75,00	14,00	30,00	1,21	
21	113,40	15115021	106,52	80,00	16,00	30,00	1,35	
23	123,40	15115023	116,58	80,00	16,00	30,00	1,47	
25	134,00	15115025	126,66	80,00	16,00	30,00	1,60	
27	143,50	15115027	136,74	80,00	16,00	30,00	2,00	
30	158,70	15115030	151,87	90,00	20,00	35,00	2,41	

MATERIAL C 45 UNI 7845

 CAD drawings available on our site
www.chiaravalli.com

 Quantity, availability and prices
 on B2B Chiaravalli



SIMPLEX CHAIN SPROCKETS HARDENED

HRC 45 ÷ 53

31

1

MATERIAL C 45 UNI 7845

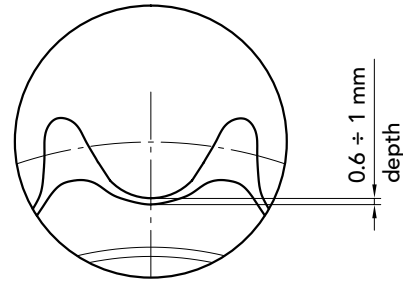

PITCH	Z	de	PART NUMBER	dp	dm	D1	A	Kg
3/4" x 7/16"	13	87,50	15119013	79,59	58,00	14,00	35,00	0,80
	14	93,80	15119014	85,61	64,00	16,00	35,00	0,97
	15	99,80	15119015	91,63	70,00	16,00	35,00	1,16
	16	105,50	15119016	97,65	75,00	16,00	35,00	1,34
	17	111,50	15119017	103,67	80,00	16,00	35,00	1,53
	18	118,00	15119018	109,71	80,00	16,00	35,00	1,62
	19	124,20	15119019	115,75	80,00	16,00	35,00	1,70
	20	129,70	15119020	121,78	80,00	16,00	35,00	1,80
	21	136,00	15119021	127,82	90,00	20,00	40,00	2,35
	23	149,00	15119023	139,90	90,00	20,00	40,00	2,56
1" x 17,02	25	160,00	15119025	152,00	90,00	20,00	40,00	2,80
	27	171,60	15119027	164,09	90,00	20,00	40,00	3,10
	30	189,80	15119030	182,25	95,00	20,00	40,00	3,30
	13	117,00	15125013	106,12	78,00	16,00	40,00	1,77
	14	125,70	15125014	114,15	84,00	16,00	40,00	2,08
	15	133,00	15125015	122,17	92,00	16,00	40,00	2,46
	16	141,00	15125016	130,20	100,00	19,00	45,00	3,14
	17	149,00	15125017	138,22	100,00	20,00	45,00	3,34
	18	157,00	15125018	146,28	100,00	20,00	45,00	3,56
	19	165,20	15125019	154,33	100,00	20,00	45,00	3,78
20	173,00	15125020	162,38	100,00	20,00	45,00	4,03	
21	181,20	15125021	170,43	110,00	20,00	50,00	5,14	
23	197,60	15125023	186,54	110,00	20,00	50,00	5,56	
25	213,70	15125025	202,66	110,00	20,00	50,00	6,16	
27	229,60	15125027	218,79	110,00	20,00	50,00	7,00	
30	254,60	15125030	243,00	120,00	20,00	50,00	8,38	

SIMPLEX CHAIN SPROCKETS HARDENED HRC 45 ÷ 53

MATERIAL C 45 UNI 7845

CAD drawings available on our site
www.chiaravalli.com

Quantity, availability and prices
 on B2B Chiaravalli



SIMPLEX CHAIN SPROCKETS WITH HARDENED TEETH WITH HOLE + KEYWAY + SCREW HOLES



3/8" x 7/32" 06B-1

CHAIN SPROCKETS

Sprockets tooth width B_1 5,3 mm

CHAIN

Pitch 9,525 mm

Inner width 5,72 mm

Roller \varnothing 9,35 mm

KEYWAY DIN 6885 UNI 6604

Hardened teeth HRC 45±53

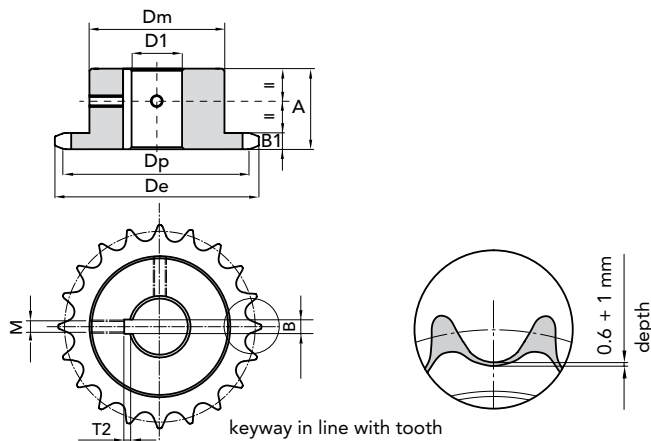

SIMPLEX CHAIN SPROCKETS 3/8"x7/32" 06B-1 for roller chains in compliance with DIN 8187 - ISO/R 606

Z	P. NUMBER	d_e	d_p	d_m	A	$\varnothing D1$ H7	B H9	T2	M	Z	P. NUMBER	d_e	d_p	d_m	A	$\varnothing D1$ H7	B H9	T2	M
12	16091212	40,45	36,8	25	25	12	4	1,8	M4	18	16091814	58,3	54,85	43	28	14	5	2,3	M4
	16091214			29		14	5	2,3	M4		16091815					15	5	2,3	M4
	16091215			30		15	5	2,3	M4		16091816					16	5	2,3	M4
	16091216			31		16	5	2,3	M4		16091818					18	6	2,8	M5
13	16091312	43,5	39,8	28	25	12	4	1,8	M4		16091819					19	6	2,8	M5
	16091314					14	5	2,3	M4		16091820					20	6	2,8	M5
	16091315					15	5	2,3	M4		16091822					22	6	2,8	M5
	16091316					16	5	2,3	M4		16091824					24	8	3,3	M6
	16091318					18	6	2,8	M5	19	16091915	61,6	57,87	45	28	15	5	2,3	M4
14	16091412	46,5	42,8	31	25	12	4	1,8	M4		16091916					16	5	2,3	M4
	16091414					14	5	2,3	M4		16091918					18	6	2,8	M5
	16091415					15	5	2,3	M4		16091919					19	6	2,8	M5
	16091416					16	5	2,3	M4		16091920					20	6	2,8	M5
	16091418					18	6	2,8	M5		16091922					22	6	2,8	M5
15	16091514	49,5	45,81	34	25	14	5	2,3	M4		16091924					24	8	3,3	M6
	16091515					15	5	2,3	M4		16091925					25	8	3,3	M6
	16091516					16	5	2,3	M4	20	16092015	64,3	60,89	46	28	15	5	2,3	M4
	16091518					18	6	2,8	M5		16092016					16	5	2,3	M4
	16091519					19	6	2,8	M5		16092018					18	6	2,8	M5
	16091520					20	6	2,8	M5		16092019					19	6	2,8	M5
	16091522					22	6	2,8	M5		16092020					20	6	2,8	M5
	16091524					24	8	3,3	M6		16092022					22	6	2,8	M5
16	16091614	52,3	48,82	37	28	14	5	2,3	M4		16092024					24	8	3,3	M6
	16091615					15	5	2,3	M4		16092025					25	8	3,3	M6
	16091616					16	5	2,3	M4	21	16092115	67,6	63,91	48	28	15	5	2,3	M4
	16091618					18	6	2,8	M5		16092116					16	5	2,3	M4
	16091619					19	6	2,8	M5		16092118					18	6	2,8	M5
	16091620					20	6	2,8	M5		16092119					19	6	2,8	M5
	16091622					22	6	2,8	M5		16092120					20	6	2,8	M5
	16091624					24	8	3,3	M6		16092122					22	6	2,8	M5
17	16091714	55,5	51,83	40	28	14	5	2,3	M4		16092124					24	8	3,3	M6
	16091715					15	5	2,3	M4		16092125					25	8	3,3	M6
	16091716					16	5	2,3	M4										
	16091718					18	6	2,8	M5										
	16091719					19	6	2,8	M5										
	16091720					20	6	2,8	M5										
	16091722					22	6	2,8	M5										
	16091724					24	8	3,3	M6										

MATERIAL **C 45 UNI 7845**

CAD drawings available on our site
www.chiaravalli.com

Quantity, availability and prices
 on B2B Chiaravalli





SIMPLEX CHAIN SPROCKETS WITH HARDENED TEETH WITH HOLE + KEYWAY + SCREW HOLES

3/8" x 7/32" 06B-1

CHAIN SPROCKETS

Sprockets tooth width B_1 5,3 mm

CHAIN

Pitch 9,525 mm
 Inner width 5,72 mm
 Roller \varnothing 9,35 mm

KEYWAY DIN 6885 UNI 6604

Hardened teeth HRC 45÷53

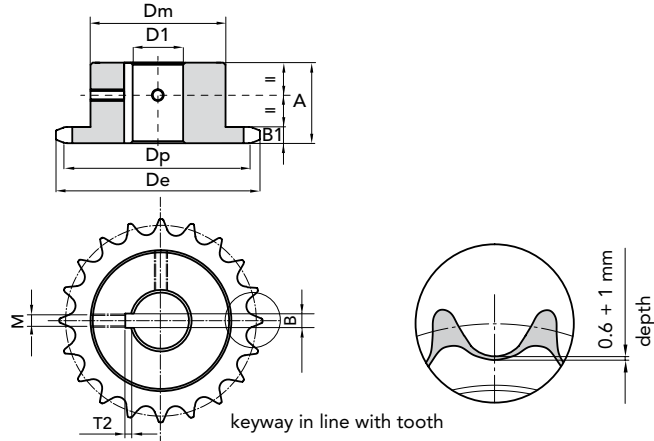

Z	P. NUMBER	d_e	d_p	d_m	A	$\varnothing D1$ H7	B H9	T2	M
23	16092315	73,7	69,95	52	28	15	5	2,3	M4
	16092316					16	5	2,3	M4
	16092318					18	6	2,8	M5
	16092319					19	6	2,8	M5
	16092320					20	6	2,8	M5
	16092322					22	6	2,8	M5
	16092324					24	8	3,3	M6
	16092325					25	8	3,3	M6
24	16092418	76,7	72,97	54	28	18	6	2,8	M5
	16092419					19	6	2,8	M5
	16092420					20	6	2,8	M5
	16092422					22	6	2,8	M5
	16092424					24	8	3,3	M6
	16092425					25	8	3,3	M6
	16092428					28	8	3,3	M6
	16092430					30	8	3,3	M6
25	16092518	79,7	76	57	28	18	6	2,8	M5
	16092519					19	6	2,8	M5
	16092520					20	6	2,8	M5
	16092522					22	6	2,8	M5
	16092524					24	8	3,3	M6
	16092525					25	8	3,3	M6
	16092528					28	8	3,3	M6
	16092530					30	8	3,3	M6
27	16092720	85,7	82,05	60	28	20	6	2,8	M5
	16092722					22	6	2,8	M5
	16092724					24	8	3,3	M6
	16092725					25	8	3,3	M6
	16092728					28	8	3,3	M6
	16092730					30	8	3,3	M6
30	16093020	94,8	91,12	60	30	20	6	2,8	M5
	16093022					22	6	2,8	M5
	16093024					24	8	3,3	M6
	16093025					25	8	3,3	M6
	16093028					28	8	3,3	M6
	16093030					30	8	3,3	M6

MATERIAL **C 45 UNI 7845**

CAD drawings available on our site
www.chiaravalli.com

Quantity, availability and prices
 on B2B Chiaravalli



SIMPLEX CHAIN SPROCKETS 3/8"x7/32" 06B-1 for roller chains in compliance with DIN 8187 - ISO/R 606

SIMPLEX CHAIN SPROCKETS WITH HARDENED TEETH WITH HOLE + KEYWAY + SCREW HOLES



1/2" x 5/16" 08B-1

CHAIN SPROCKETS

Sprockets tooth width B_1 7,2 mm

CHAIN

Pitch 12,7 mm

Inner width 7,75 mm

Roller \varnothing 8,51 mm

KEYWAY DIN 6885 UNI 6604

Hardened teeth HRC 45÷53

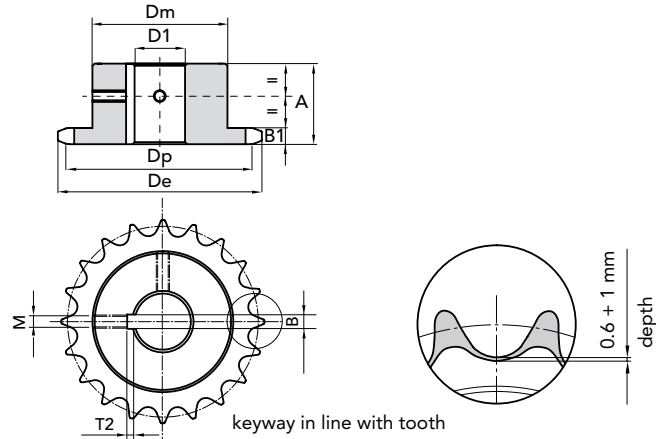

SIMPLEX CHAIN SPROCKETS 1/2"x5/16" 08B-1 for roller chains in compliance with DIN 8187 - ISO/R

Z	P. NUMBER	d_e	d_p	d_m	A	$\varnothing D1$ H7	B H9	T2	M	ZP. NUMBER	d_e	d_p	d_m	A	$\varnothing D1$ H7	B H9	T2	M	
12	1612121 2	53,9	49,07	33	28	12	4	1,8	M4	16	16121615	69,5	65,1	50	28	15	5	2,3	M4
	16121214					14	5	2,3	M4		16121616					16	5	2,3	M4
	16121215					15	5	2,3	M4		16121618					18	6	2,8	M5
	16121216					16	5	2,3	M4		16121619					19	6	2,8	M5
	16121218					18	6	2,8	M5		16121620					20	6	2,8	M5
	16121219					19	6	2,8	M5		16121622					22	6	2,8	M5
	16121220					20	6	2,8	M5		16121624					24	8	3,3	M6
13	16121312	57,9	53,06	37	28	12	4	1,8	M4		16121625					25	8	3,3	M6
	16121314					14	5	2,3	M4		16121628					28	8	3,3	M6
	16121315					15	5	2,3	M4		16121630					30	8	3,3	M6
	16121316					16	5	2,3	M4	17	16121715	74	69,11	52	28	15	5	2,3	M4
	16121318					18	6	2,8	M5		16121716					16	5	2,3	M4
	16121319					19	6	2,8	M5		16121718					18	6	2,8	M5
	16121320					20	6	2,8	M5		16121719					19	6	2,8	M5
	16121322					22	6	2,8	M5		16121720					20	6	2,8	M5
	16121324					24	8	3,3	M6		16121722					22	6	2,8	M5
14	16121414	61,6	57,07	41	28	14	5	2,3	M4		16121724					24	8	3,3	M6
	16121415					15	5	2,3	M4		16121725					25	8	3,3	M6
	16121416					16	5	2,3	M4		16121728					28	8	3,3	M6
	16121418					18	6	2,8	M5		16121730					30	8	3,3	M6
	16121419					19	6	2,8	M5	18	16121816	77,8	73,14	56	28	16	5	2,3	M4
	16121420					20	6	2,8	M5		16121818					18	6	2,8	M5
	16121422					22	6	2,8	M5		16121819					19	6	2,8	M5
	16121424					24	8	3,3	M6		16121820					20	6	2,8	M5
	16121425					25	8	3,3	M6		16121822					22	6	2,8	M5
15	16121514	65,9	61,09	45	28	14	5	2,3	M4		16121824					24	8	3,3	M6
	16121515					15	5	2,3	M4		16121825					25	8	3,3	M6
	16121516					16	5	2,3	M4		16121828					28	8	3,3	M6
	16121518					18	6	2,8	M5		16121830					30	8	3,3	M6
	16121519					19	6	2,8	M5		16121832					32	10	3,3	M8
	16121520					20	6	2,8	M5		16121835					35	10	3,3	M8
	16121522					22	6	2,8	M5										
	16121524					24	8	3,3	M6										
	16121525					25	8	3,3	M6										
	16121528					28	8	3,3	M6										
	16121530					30	8	3,3	M6										

MATERIAL **C 45 UNI 7845**

CAD drawings available on our site
www.chiaravalli.com

Quantity, availability and prices
 on B2B Chiaravalli





SIMPLEX CHAIN SPROCKETS WITH HARDENED TEETH WITH HOLE + KEYWAY + SCREW HOLES

1/2" x 5/16" 08B-1

CHAIN SPROCKETS

Sprockets tooth width B_1 7,2 mm

CHAIN

Pitch 12,7 mm

Inner width 7,75 mm

Roller \varnothing 8,51 mm

KEYWAY DIN 6885 UNI 6604

Hardened teeth HRC 45÷53

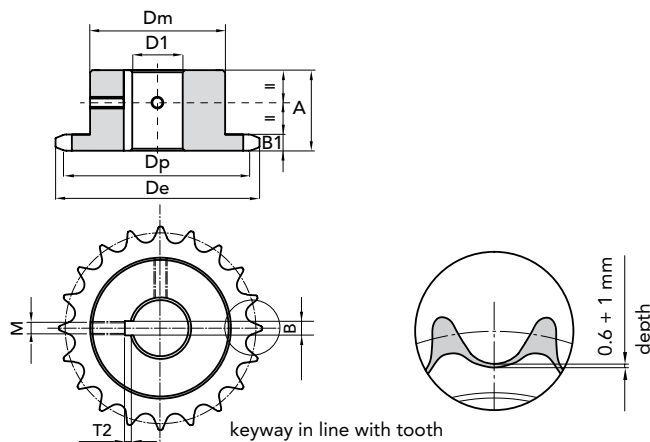

Z	P. NUMBER	d_e	d_p	dm	A	$\varnothing D1$ H7	B H9	T2	M
19	16121919	82	77,16	60	28	19	6	2,8	M5
	16121920					20	6	2,8	M5
	16121922					22	6	2,8	M5
	16121924					24	8	3,3	M6
	16121925					25	8	3,3	M6
	16121928					28	8	3,3	M6
	16121930					30	8	3,3	M6
	16121932					32	10	3,3	M8
	16121935					35	10	3,3	M8
20	16122019	85,8	81,19	64	28	19	6	2,8	M5
	16122020					20	6	2,8	M5
	16122022					22	6	2,8	M5
	16122024					24	8	3,3	M6
	16122025					25	8	3,3	M6
	16122028					28	8	3,3	M6
	16122030					30	8	3,3	M6
	16122032					32	10	3,3	M8
	16122035					35	10	3,3	M8
21	16122119	90,1	85,22	68	28	19	6	2,8	M5
	16122120					20	6	2,8	M5
	16122122					22	6	2,8	M5
	16122124					24	8	3,3	M6
	16122125					25	8	3,3	M6
	16122128					28	8	3,3	M6
	16122130					30	8	3,3	M6
	16122132					32	10	3,3	M8
	16122135					35	10	3,3	M8
23	16122320	98,1	93,27	70	28	20	6	2,8	M5
	16122322					22	6	2,8	M5
	16122324					24	8	3,3	M6
	16122325					25	8	3,3	M6
	16122328					28	8	3,3	M6
	16122330					30	8	3,3	M6
	16122332					32	10	3,3	M8
	16122335					35	10	3,3	M8
	16122338					38	10	3,3	M8

Z	P. NUMBER	d_e	d_p	dm	A	$\varnothing D1$ H7	B H9	T2	M
24	16122420	102,1	97,29	70	28	20	6	2,8	M5
	16122422					22	6	2,8	M5
	16122424					24	8	3,3	M6
	16122425					25	8	3,3	M6
	16122428					28	8	3,3	M6
	16122430					30	8	3,3	M6
	16122432					32	8	3,3	M8
	16122435					35	10	3,3	M8
	16122438					38	10	3,3	M8
25	16122520	105,8	101,33	70	28	20	6	2,8	M5
	16122522					22	6	2,8	M5
	16122524					24	8	3,3	M6
	16122525					25	8	3,3	M6
	16122528					28	8	3,3	M6
	16122530					30	8	3,3	M6
	16122532					32	10	3,3	M8
	16122535					35	10	3,3	M8
	16122538					38	10	3,3	M8
27	16122722	114	109,4	70	30	22	6	2,8	M5
	16122725					25	8	3,3	M6
	16122728					28	8	3,3	M6
	16122730					30	8	3,3	M6
	16122732					32	10	3,3	M8
	16122735					35	10	3,3	M8
	16122738					38	10	3,3	M8
30	16123025	126	121,5	80	30	25	8	3,3	M6
	16123028					28	8	3,3	M6
	16123030					30	8	3,3	M6
	16123032					32	10	3,3	M8
	16123035					35	10	3,3	M8
	16123038					38	10	3,3	M8

MATERIAL C 45 UNI 7845

CAD drawings available on our site
www.chiaravalli.com

Quantity, availability and prices
 with B2B Chiaravalli



SIMPLEX CHAIN SPROCKETS 1/2"x5/16" 08B-1 for roller chains in compliance with DIN 8187 - ISO/R

SIMPLEX CHAIN SPROCKETS WITH HARDENED TEETH WITH HOLE + KEYWAY + SCREW HOLES



5/8" x 3/8" 10B-1

CHAIN SPROCKETS

Sprockets tooth width B_1 9,1 mm

CHAIN

Pitch 15,875 mm

Inner width 9,65 mm

Roller \varnothing 10,16 mm

KEYWAY DIN 6885 UNI 6604

Hardened teeth HRC 45÷53

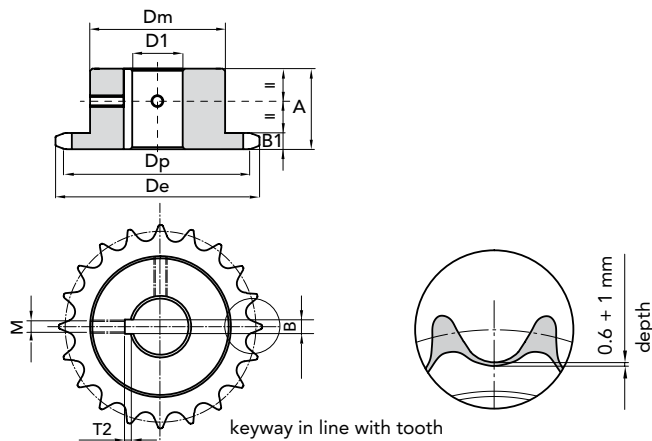

SIMPLEX CHAIN SPROCKETS 5/8"x3/8" 10B-1 for roller chains in compliance with DIN 8187 - ISO/R 606

Z	P. NUMBER	d_e	d_p	d_m	A	$\varnothing D1$ H7	B H9	T2	M	Z	P. NUMBER	d_e	d_p	d_m	A	$\varnothing D1$ H7	B H9	T2	M
12	16151216	68,2	61,34	42	30	16	5	2,3	M4	16	16151620	88	81,37	60	30	20	6	2,8	M5
	16151219					19	6	2,8	M5		16151622					22	6	2,8	M5
	16151220					20	6	2,8	M5		16151624					24	8	3,3	M6
	16151222					22	6	2,8	M5		16151625					25	8	3,3	M6
	16151224					24	8	3,3	M6		16151628					28	8	3,3	M6
	16151225					25	8	3,3	M6		16151630					30	8	3,3	M6
	16151228			51		28	8	3,3	M6		16151632					32	10	3,3	M8
	16151230			51		30	8	3,3	M6		16151635					35	10	3,3	M8
13	16151316	73,2	66,32	47	30	16	5	2,3	M4	17	16151720	93,2	86,39	60	30	20	6	2,8	M5
	16151319					19	6	2,8	M5		16151722					22	6	2,8	M5
	16151320					20	6	2,8	M5		16151724					24	8	3,3	M6
	16151322					22	6	2,8	M5		16151725					25	8	3,3	M6
	16151324					24	8	3,3	M6		16151728					28	8	3,3	M6
	16151325					25	8	3,3	M6		16151730					30	8	3,3	M6
	16151328					28	8	3,3	M6		16151732					32	10	3,3	M8
	16151330					30	8	3,3	M6		16151735					35	10	3,3	M8
14	16151416	78,2	71,34	52	30	16	5	2,3	M4	18	16151820	98,3	91,42	70	30	20	6	2,8	M5
	16151419					19	6	2,8	M5		16151822					22	6	2,8	M5
	16151420					20	6	2,8	M5		16151824					24	8	3,3	M6
	16151422					22	6	2,8	M5		16151825					25	8	3,3	M6
	16151424					24	8	3,3	M6		16151828					28	8	3,3	M6
	16151425					25	8	3,3	M6		16151830					30	8	3,3	M6
	16151428					28	8	3,3	M6		16151832					32	10	3,3	M8
	16151430					30	8	3,3	M6		16151835					35	10	3,3	M8
15	16151519	83,2	76,36	57	30	19	6	2,8	M5		16151838					38	10	3,3	M8
	16151520					20	6	2,8	M5		16151840					40	12	3,3	M10
	16151522					22	6	2,8	M5	19	16151920	103,3	96,45	70	30	20	6	2,8	M5
	16151524					24	8	3,3	M6		16151922					22	6	2,8	M5
	16151525					25	8	3,3	M6		16151924					24	8	3,3	M6
	16151528					28	8	3,3	M6		16151925					25	8	3,3	M6
	16151530					30	8	3,3	M6		16151928					28	8	3,3	M6
	16151532					32	10	3,3	M8		16151930					30	8	3,3	M6
	16151535					35	10	3,3	M8		16151932					32	10	3,3	M8
											16151935					35	10	3,3	M8
											16151938					38	10	3,3	M8
											16151940					40	12	3,3	M10

MATERIAL **C 45 UNI 7845**

CAD drawings available on our site
www.chiaravalli.com

Quantity, availability and prices
 on B2B Chiaravalli





SIMPLEX CHAIN SPROCKETS WITH HARDENED TEETH WITH HOLE + KEYWAY + SCREW HOLES

5/8" x 3/8" 10B-1

CHAIN SPROCKETS

Sprockets tooth width B_1 9,1 mm

CHAIN

Pitch 15,875 mm

Inner width 9,65 mm

Roller \varnothing 10,16 mm

KEYWAY DIN 6885 UNI 6604

Hardened teeth HRC 45÷53

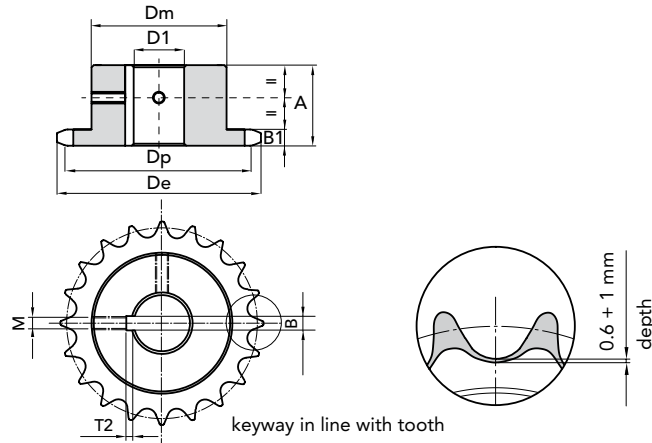

Z	P. NUMBER	d_e	d_p	d_m	A	$\varnothing D1$ H7	B H9	T2	M
20	16152020	108,4	101,49	75	30	20	6	2,8	M5
	16152022					22	6	2,8	M5
	16152024					24	8	3,3	M6
	16152025					25	8	3,3	M6
	16152028					28	8	3,3	M6
	16152030					30	8	3,3	M6
	16152032					32	10	3,3	M8
	16152035					35	10	3,3	M8
	16152038					38	10	3,3	M8
	16152040					40	12	3,3	M10
21	16152120	113,4	106,52	75	30	20	6	2,8	M5
	16152122					22	6	2,8	M5
	16152124					24	8	3,3	M6
	16152125					25	8	3,3	M6
	16152128					28	8	3,3	M6
	16152130					30	8	3,3	M6
	16152132					32	10	3,3	M8
	16152135					35	10	3,3	M8
	16152138					38	10	3,3	M8
	16152140					40	12	3,3	M10
23	16152320	123,4	116,58	80	30	20	6	2,8	M5
	16152322					22	6	2,8	M5
	16152324					24	8	3,3	M6
	16152325					25	8	3,3	M6
	16152328					28	8	3,3	M6
	16152330					30	8	3,3	M6
	16152332					32	10	3,3	M8
	16152335					35	10	3,3	M8
	16152338					38	10	3,3	M8
	16152340					40	12	3,3	M10
	16152342					42	12	3,3	M10

Z	P. NUMBER	d_e	d_p	d_m	A	$\varnothing D1$ H7	B H9	T2	M
24	16152420	128,5	121,62	80	30	20	6	2,8	M5
	16152422					22	6	2,8	M5
	16152424					24	8	3,3	M6
	16152425					25	8	3,3	M6
	16152428					28	8	3,3	M6
	16152430					30	8	3,3	M6
	16152432					32	10	3,3	M8
	16152435					35	10	3,3	M8
	16152438					38	10	3,3	M8
	16152440					40	12	3,3	M10
	16152442					42	12	3,3	M10
25	16152522	133,5	126,66	80	30	22	6	2,8	M5
	16152524					24	8	3,3	M6
	16152525					25	8	3,3	M6
	16152528					28	8	3,3	M6
	16152530					30	8	3,3	M6
	16152532					32	10	3,3	M8
	16152535					35	10	3,3	M8
	16152538					38	10	3,3	M8
	16152540					40	12	3,3	M10
	16152542					42	12	3,3	M10

MATERIAL **C 45 UNI 7845**

CAD drawings available on our site
www.chiaravalli.com

Quantity, availability and prices
on B2B Chiaravalli



SIMPLEX CHAIN SPROCKETS WITH HARDENED TEETH WITH HOLE + KEYWAY + SCREW HOLES



3/4" x 7/16" 12B-1

CHAIN SPROCKETS

Sprockets tooth width B_1 11,1 mm

CHAIN

Pitch 19,05 mm

Inner width 11,68 mm

Roller \varnothing 12,07 mm

KEYWAY DIN 6885 UNI 6604

Hardened teeth HRC 45÷53

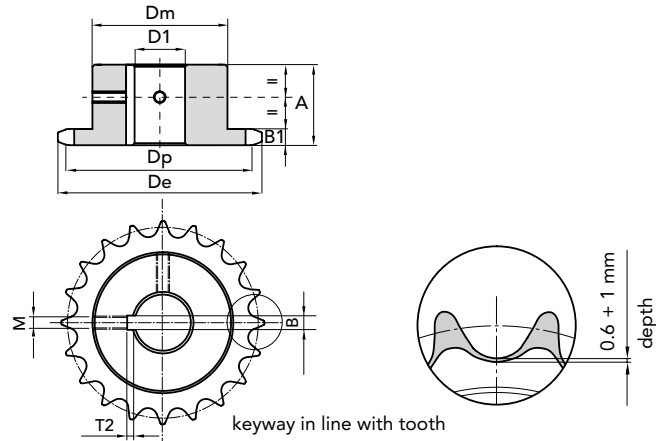

SIMPLEX CHAIN SPROCKETS 3/4"x7/16" 12B-1 for roller chains in compliance with DIN 8187 - ISO/R

Z	P. NUMBER	d_e	d_p	d_m	A	$\varnothing D1$ H7	B H9	T2	M	Z	P. NUMBER	d_e	d_p	d_m	A	$\varnothing D1$ H7	B H9	T2	M
12	16191220	81,8	73,6	52	35	20	6	2,8	M5	16	16191620	105,5	97,65	75	35	20	6	2,8	M5
	16191222					22	6	2,8	M5		16191622					22	6	2,8	M5
	16191224					24	8	3,3	M6		16191624	ON DEMAND				24	8	3,3	M6
	16191225					25	8	3,3	M6		16191625					25	8	3,3	M6
	16191228					28	8	3,3	M6		16191628					28	8	3,3	M6
	16191230					30	8	3,3	M6		16191630					30	8	3,3	M6
13	16191320	87,1	79,6	58	35	20	6	2,8	M5		16191632					32	10	3,3	M8
	16191322					22	6	2,8	M5		16191635					35	10	3,3	M8
	16191324					24	8	3,3	M6		16191638					38	10	3,3	M8
	16191325					25	8	3,3	M6		16191640					40	12	3,3	M10
	16191328					28	8	3,3	M6	17	16191722	111,2	103,67	80	35	22	6	2,8	M5
	16191330					30	8	3,3	M6		16191725					25	8	3,3	M6
	16191332					32	10	3,3	M8		16191728					28	8	3,3	M6
	16191335					35	10	3,3	M8		16191730					30	8	3,3	M6
14	16191420	93,8	85,61	64	35	20	6	2,8	M5		16191732					32	10	3,3	M8
	16191422					22	6	2,8	M5		16191735					35	10	3,3	M8
	16191424					24	8	3,3	M6		16191738					38	10	3,3	M8
	16191425					25	8	3,3	M6		16191740					40	12	3,3	M10
	16191428					28	8	3,3	M6	18	16191822	118	109,71	80	35	22	6	2,8	M5
	16191430					30	8	3,3	M6		16191825					25	8	3,3	M6
	16191432					32	10	3,3	M8		16191828					28	8	3,3	M6
	16191435					35	10	3,3	M8		16191830					30	8	3,3	M6
15	16191520	99,2	91,63	70	35	20	6	2,8	M5		16191832					32	10	3,3	M8
	16191522					22	6	2,8	M5		16191835					35	10	3,3	M8
	16191524					24	8	3,3	M6		16191838					38	10	3,3	M8
	16191525					25	8	3,3	M6		16191840					40	12	3,3	M10
	16191528					28	8	3,3	M6	19	16191925	123,3	115,75	80	35	25	8	3,3	M6
	16191530					30	8	3,3	M6		16191928					28	8	3,3	M6
	16191532					32	10	3,3	M8		16191930					30	8	3,3	M6
	16191535					35	10	3,3	M8		16191932					32	10	3,3	M8
	16191538					38	10	3,3	M8		16191935					35	10	3,3	M8
	16191540					40	12	3,3	M10		16191938					38	10	3,3	M8
											16191940					40	12	3,3	M10
											16191942					42	12	3,3	M10
											16191945					45	14	3,8	M12

MATERIAL **C 45 UNI 7845**

CAD drawings available on our site
www.chiaravalli.com

Quantity, availability and prices
 on B2B Chiaravalli





SIMPLEX CHAIN SPROCKETS WITH HARDENED TEETH WITH HOLE + KEYWAY + SCREW HOLES

3/4" x 7/16" 12B-1

CHAIN SPROCKETS

Sprockets tooth width B_1 11,1 mm

CHAIN

Pitch 19,05 mm
 Inner width 11,68 mm
 Roller \varnothing 12,07 mm

KEYWAY DIN 6885 UNI 6604

Hardened teeth HRC 45÷53

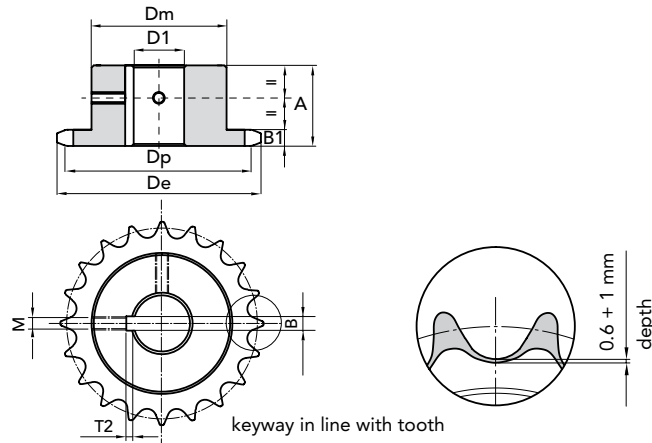

Z	P. NUMBER	d_e	d_p	d_m	A	$\varnothing D1$ H7	B H9	T2	M
20	16192025	129,7	121,78	80	35	25	8	3,3	M6
	16192028					28	8	3,3	M6
	16192030					30	8	3,3	M6
	16192032					32	10	3,3	M8
	16192035					35	10	3,3	M8
	161920a38					38	10	3,3	M8
	16192040					40	12	3,3	M10
	16192042					42	12	3,3	M10
	16192045					45	14	3,8	M12
21	16192128	135,4	127,82	90	40	28	8	3,3	M6
	16192130					30	8	3,3	M6
	16192132					32	10	3,3	M8
	16192135					35	10	3,3	M8
	16192138					38	10	3,3	M8
	16192140					40	12	3,3	M10
	16192142					42	12	3,3	M10
	16192145					45	14	3,8	M12
	16192148					48	14	3,8	M12
	16192150					50	14	3,8	M12
23	16192328	147,4	139,9	90	40	28	8	3,3	M6
	16192330					30	8	3,3	M6
	16192332					32	10	3,3	M8
	16192335					35	10	3,3	M8
	16192338					38	10	3,3	M8
	16192340					40	12	3,3	M10
	16192342					42	12	3,3	M10
	16192345					45	14	3,8	M12
	16192348					48	14	3,8	M12
	16192350					50	14	3,8	M12

Z	P. NUMBER	d_e	d_p	d_m	A	$\varnothing D1$ H7	B H9	T2	M
24	16192428	154,1	145,94	90	40	28	8	3,3	M6
	16192430					30	8	3,3	M6
	16192432					32	10	3,3	M8
	16192435					35	10	3,3	M8
	16192438					38	10	3,3	M8
	16192440					40	12	3,3	M10
	16192442					42	12	3,3	M10
	16192445					45	14	3,8	M12
	16192448					48	14	3,8	M12
	16192450					50	14	3,8	M12
25	16192528	159,5	152	90	40	28	8	3,3	M6
	16192530					30	8	3,3	M6
	16192532					32	10	3,3	M8
	16192535					35	10	3,3	M8
	16192538					38	10	3,3	M8
	16192540					40	12	3,3	M10
	16192542					42	12	3,3	M10
	16192545					45	14	3,8	M12
	16192548					48	14	3,8	M12
	16192550					50	14	3,8	M12

SIMPLEX CHAIN SPROCKETS 3/4"x7/16" 12B-1 for roller chains in compliance with DIN 8187 - ISO/R

MATERIAL **C 45 UNI 7845**

CAD drawings available on our site
www.chiaravalli.com

Quantity, availability and prices
 on B2B Chiaravalli



SIMPLEX CHAIN SPROCKETS WITH HARDENED TEETH WITH HOLE + KEYWAY + SCREW HOLES



1" x 17.02 16B-1

CHAIN SPROCKETS

Sprockets tooth width B_1 16,2 mm

CHAIN

Pitch 25,4 mm
Inner width 17,02 mm
Roller \varnothing 15,88 mm

KEYWAY DIN 6885 UNI 6604

Hardened teeth HRC 45÷53

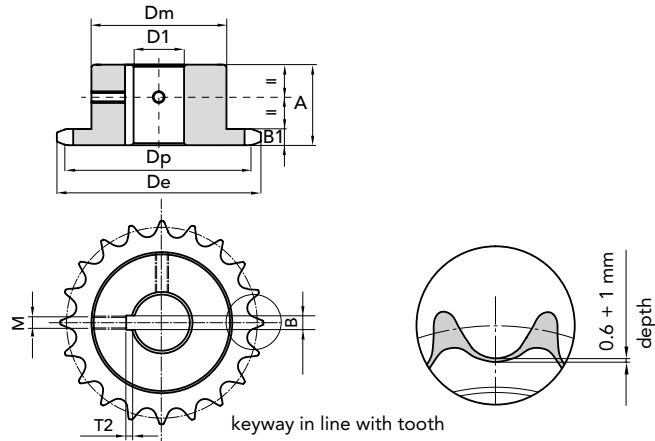

SIMPLEX CHAIN SPROCKETS 1" x 17.02 16B-1 for roller chains in compliance with DIN 8187 - ISO/R 606

Z	P. NUMBER	d_e	d_p	dm	A	$\varnothing D1$ H7	B H9	T2	M	Z	P. NUMBER	d_e	d_p	dm	A	$\varnothing D1$ H7	B H9	T2	M
12	16251225	109,71	98,14	69	40	25	8	3,3	M6	16	16251630	141	130,2	100	45	30	8	3,3	M6
	16251228					28	8	3,3	M6		16251632					32	10	3,3	M8
	16251230					30	8	3,3	M6		16251635					35	10	3,3	M8
	16251232					32	10	3,3	M8		16251638					38	10	3,3	M8
	16251235					35	10	3,3	M8		16251640					40	12	3,3	M10
	16251238					38	10	3,3	M8		16251642					42	12	3,3	M10
	16251240					40	12	3,3	M10		16251645					45	14	3,8	M12
13	16251325	117,2	106,14	78	40	25	8	3,3	M6		16251648					48	14	3,8	M12
	16251328					28	8	3,3	M6		16251650					50	14	3,8	M12
	16251330					30	8	3,3	M6	17	16251730	149,4	138,22	100	45	30	8	3,3	M6
	16251332					32	10	3,3	M8		16251732					32	10	3,3	M8
	16251335					35	10	3,3	M8		16251735					35	10	3,3	M8
	16251338					38	10	3,3	M8		16251738					38	10	3,3	M8
	16251340					40	12	3,3	M10		16251740					40	12	3,3	M10
	16251342					42	12	3,3	M10		16251742					42	12	3,3	M10
	16251345					45	14	3,8	M12		16251745					45	14	3,8	M12
14	16251425	125,7	114,15	84	40	25	8	3,3	M6		16251748					48	14	3,8	M12
	16251428					28	8	3,3	M6		16251750					50	14	3,8	M12
	16251430					30	8	3,3	M6	18	16251830	157	146,28	100	45	30	8	3,3	M6
	16251432					32	10	3,3	M8		16251832					32	10	3,3	M8
	16251435					35	10	3,3	M8		16251835					35	10	3,3	M8
	16251438					38	10	3,3	M8		16251838					38	10	3,3	M8
	16251440					40	12	3,3	M10		16251840					40	12	3,3	M10
	16251442					42	12	3,3	M10		16251842					42	12	3,3	M10
	16251445					45	14	3,8	M12		16251845					45	14	3,8	M12
	16251448					48	14	3,8	M12		16251848					45	14	3,8	M12
	16251450					50	14	3,8	M12		16251850					50	14	3,8	M12
15	16251528	133,3	122,17	92	40	28	8	3,3	M6	19	16251930	165,5	154,33	100	45	30	8	3,3	M6
	16251530					30	8	3,3	M6		16251932					32	10	3,3	M8
	16251532					32	10	3,3	M8		16251935					35	10	3,3	M8
	16251535					35	10	3,3	M8		16251938					38	10	3,3	M8
	16251538					38	10	3,3	M8		16251940					40	12	3,3	M10
	16251540					40	12	3,3	M10		16251942					45	12	3,3	M10
	16251542					42	12	3,3	M10		16251945					45	14	3,8	M12
	16251545					45	14	3,8	M12		16251948					48	14	3,8	M12
	16251548					48	14	3,8	M12		16251950					50	14	3,8	M12
	16251550					50	14	3,8	M12										

MATERIAL **C 45 UNI 7845**

CAD drawings available on our site
www.chiaravalli.com

Quantity, availability and prices
on B2B Chiaravalli





SIMPLEX CHAIN SPROCKETS WITH HARDENED TEETH WITH HOLE + KEYWAY + SCREW HOLES

1" x 17.02 16B-1

CHAIN SPROCKETS

Sprockets tooth width B_1 16,2 mm

CHAIN

Pitch 25,4 mm

Inner width 17,02 mm

Roller \varnothing 15,88 mm

KEYWAY DIN 6885 UNI 6604

Hardened teeth HRC 45÷53

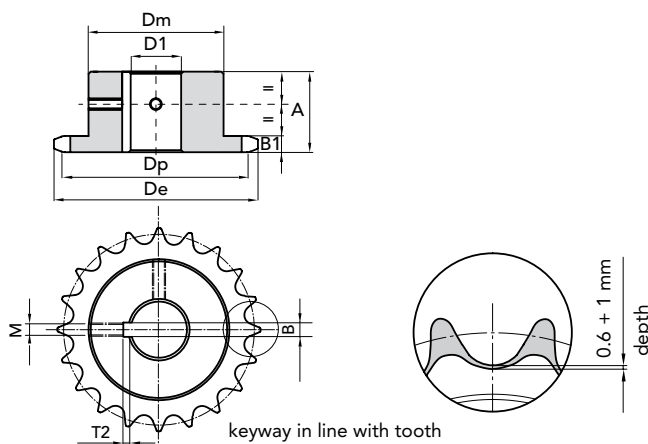

Z	P. NUMBER	d_e	d_p	d_m	A	$\varnothing D1$ H7	B H9	T2	M
20	16252030	173,2	162,38	100	45	30	8	3,3	M6
	16252032					32	10	3,3	M8
	16252035					35	10	3,3	M8
	16252038					38	10	3,3	M8
	16252040					40	12	3,3	M10
	16252042					42	12	3,3	M10
	16252045					45	14	3,8	M12
	16252048					48	14	3,8	M12
	16252050					50	14	3,8	M12
21	16252130	181,6	170,43	110	50	30	8	3,3	M6
	16252132					32	10	3,3	M8
	16252135					35	10	3,3	M8
	16252138					38	10	3,3	M8
	16252140					40	12	3,3	M10
	16252142					42	12	3,3	M10
	16252145					45	14	3,8	M12
	16252148					48	14	3,8	M12
	16252150					50	14	3,8	M12
23	16252330	198,1	186,1	110	50	30	8	3,3	M6
	16252332					32	10	3,3	M8
	16252335					35	10	3,3	M8
	16252338					38	10	3,3	M8
	16252340					40	12	3,3	M10
	16252342					42	12	3,3	M10
	16252345					45	14	3,8	M12
	16252348					48	14	3,8	M12
	16252350					50	14	3,8	M12
25	16252530	214,2	202,66	110	50	30	8	3,3	M6
	16252532					32	10	3,3	M8
	16252535					35	10	3,3	M8
	16252538					38	10	3,3	M8
	16252540					40	12	3,3	M10
	16252542					42	12	3,3	M10
	16252545					45	14	3,8	M12
	16252548					48	14	3,8	M12
	16252550					50	14	3,8	M12

MATERIAL C 45 UNI 7845

CAD drawings available on our site
www.chiaravalli.com

Quantity, availability and prices
 on B2B Chiaravalli



SIMPLEX CHAIN SPROCKETS 1"x17.02 16B-1 for roller chains in compliance with DIN 8187 - ISO/R 606

TAPER LOCK® CHAIN SPROCKETS



TAPER LOCK® CHAIN SPROCKETS

MATERIAL **STEEL**
C 45 UNI 5007

AVAILABLE ALSO
WITH INDUCTION
HARDENED TEETH

MATERIAL **IN CAST IRON**
GG20 UNI 5007

Hardened teeth HRC 45÷53

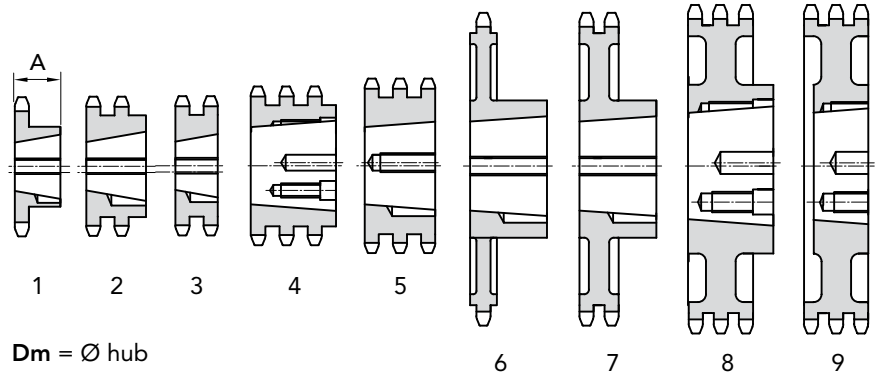

SIMPLEX

DUPLEX

PITCH	STEEL		COD.	Z	for	Exec.	Dm	A	Kg	COD.		Z	for	Exec.	Dm	A	Kg
	P. NUMBER	HARDENED P. NUMBER								PITCH	P. NUMBER						
3/8" 9,52 mm	17109017	18109017	031-17	17	1008	1	44,5	22	0,11	17209017	032-17	17	1008	2	42,5	22	0,11
	17109018	-	031-18	18	1008	1	43	22	0,14	17209018	032-18	18	1008	2	43	22	0,15
	17109019	18109019	031-19	19	1008	1	46	22	0,15	17209019	032-19	19	1008	2	46	22	0,18
	17109020	-	031-20	20	1008	1	46	22	0,16	17209020	032-20	20	1008	2	48	22	0,22
	17109021	18109021	031-21	21	1008	1	46	22	0,18	17209021	032-21	21	1008	2	49	22	0,16
	17109022	-	031-22	22	1108	1	50	22	0,25	17209022	032-22	22	1108	2	52	22	0,28
	17109023	18109023	031-23	23	1210	1	62	25	0,27	17209023	032-23	23	1210	2	58	25	0,27
	17109024	-	031-24	24	1210	1	62	25	0,30	17209024	032-24	24	1210	2	61	25	0,32
	17109025	18109025	031-25	25	1210	1	63	25	0,32	17209025	032-25	25	1210	2	64	25	0,37
	17109026	-	031-26	26	1210	1	60	25	0,33	17209026	032-26	26	1210	2	65	25	0,44
	17109027	18109027	031-27	27	1210	1	60	25	0,34	17209027	032-27	27	1210	2	65	25	0,50
	17109028	-	031-28	28	1210	1	60	25	0,37	17209028	032-28	28	1210	2	65	25	0,57
	17109030	18109030	031-30	30	1210	1	63	25	0,39	17209030	032-30	30	1210	2	65	25	0,68
	17109038	-	031-38	38	1210	1	73	25	0,65	17209038	032-38	38	1610	2	76	25	1,03
	17109045	-	031-45	45	1210	1	73	25	1,01	17209045	032-45	45	1610	2	89	25	1,08
	17109057	-	031-57	57	1210	6	83	25	1,34	17209057	032-57	57	1610	7	89	25	1,16
	17109076	-	031-76	76	1210	6	83	25	1,84	17209076	032-76	76	1610	7	89	25	2,19
	17109095	-	031-95	95	1210	6	83	25	2,30	17209095	032-95	95	1610	7	89	25	3,00
	17109114	-	031-114	114	1215	6	83	38	3,50	17209114	032-114	114	1615	7	89	38	5,00
1/2" 12,70 mm	17112015	18112015	041-15	15	1008	1	46	22	0,16	17212015	042-15	15	1008	2	46	22	0,22
	17112016	-	041-16	16	1108	1	50	22	0,20	17212016	042-16	16	1108	2	50	22	0,22
	17112017	18112017	041-17	17	1210	1	59,5	25	0,22	17212017	042-17	17	1210	2	56	25	0,23
	17112018	-	041-18	18	1210	1	60	25	0,27	17212018	042-18	18	1210	2	58	25	0,30
	17112019	18112019	041-19	19	1210	1	63	25	0,33	17212019	042-19	19	1210	2	64	25	0,38
	17112020	-	041-20	20	1610	1	71	25	0,36	17212020	042-20	20	1610	2	66	25	0,45
	17112021	18112021	041-21	21	1610	1	71	25	0,36	17212021	042-21	21	1610	2	71	25	0,50
	17112022	-	041-22	22	1610	1	70	25	0,36	17212022	042-22	22	1610	2	76	25	0,55
	17112023	18112023	041-23	23	1610	1	76	25	0,50	17212023	042-23	23	1610	2	79	25	0,62
	17112024	-	041-24	24	1610	1	70	25	0,53	17212024	042-24	24	2012	2	84	32	0,68
	17112025	18112025	041-25	25	1610	1	76	25	0,56	17212025	042-25	25	2012	2	87	32	0,72
	17112026	-	041-26	26	1610	1	70	32	0,60	17212026	042-26	26	2012	2	85	32	0,82
	17112027	18112027	041-27	27	1610	1	76	32	0,63	17212027	042-27	27	2012	2	87	32	0,92
	17112028	-	041-28	28	2012	1	90	32	0,87	17212028	042-28	28	2012	2	87	32	1,10
	17112030	18112030	041-30	30	2012	1	90	32	0,91	17212030	042-30	30	2012	2	87	32	1,24
	17112038	-	041-38	38	2012	1	102	32	1,25	17212038	042-38	38	2012	2	102	32	2,50
	17112045	-	041-45	45	2012	1	102	32	1,68	17212045	042-45	45	2012	2	111	32	3,05
	17112057	-	041-57	57	2012	6	111	32	2,78	17212057	042-57	57	2012	7	111	32	5,64
	17112076	-	041-76	76	2012	6	111	32	3,81	17212076	042-76	76	2012	7	111	32	5,69
17112095	-	041-95	95	2012	6	111	32	5,00	17212095	042-95	95	2012	7	111	32	5,10	
17112114	-	041-114	114	2517	6	124	45	6,50	17212114	042-114	114	2517	7	124	45	6,00	



CAD drawings available on our site
www.chiaravalli.com

Quantity, availability and prices
on B2B Chiaravalli



TAPER LOCK® CHAIN SPROCKETS

MATERIAL STEEL
C 45 UNI 5007

AVAILABLE ALSO WITH INDUCTION HARDENED TEETH

MATERIAL IN CAST IRON
GG20 UNI 5007

Hardened teeth HRC 45÷53

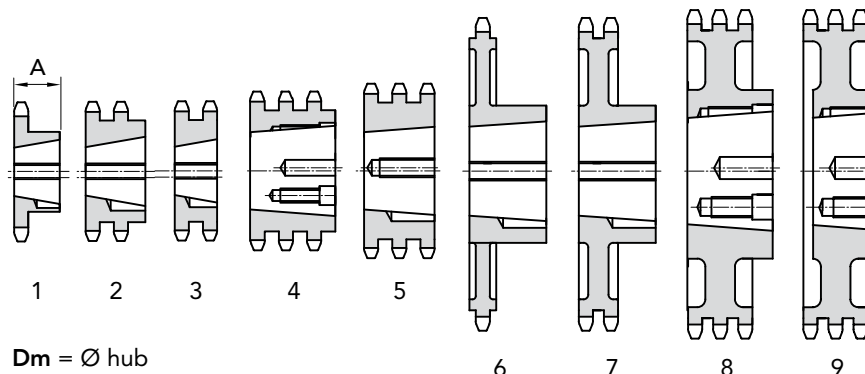

SIMPLEX

DUPLEX

PITCH	P. NUMBER		COD. PITCH	Z	for		Dm hub	A	Kg	P. NUMBER		COD. PITCH	Z	for		Dm hub	A	Kg	
	ACCIAIO	TEMPRATI			taper	Exec. bush				Type	taper			Exec. bush	Type				
5/8" 15,87 mm	17115013	18115013	051-13	13	1008	1	46	22	0,23										
	17115014	-	051-14	14	1108	1	52	22	0,27										
	17115015	18115015	051-15	15	1210	1	63	25	0,30	17215015	052-15	15	1210	3	-	25,5	0,38		
	17115016	-	051-16	16	1610	1	70	25	0,38	17215016	052-16	16	1610	3	-	25,5	0,42		
	17115017	18115017	051-17	17	1610	1	71	25	0,38	17215017	052-17	17	1610	3	-	25,5	0,47		
	17115018	-	051-18	18	1610	1	75	25	0,43	17215018	052-18	18	1610	3	-	25,5	0,66		
	17115019	18115019	051-19	19	1610	1	76	25	0,54	17215019	052-19	19	1610	3	-	25,5	0,72		
	17115020	-	051-20	20	1610	1	75	25	0,61	17215020	052-20	20	1610	3	-	25,5	0,87		
	17115021	18115021	051-21	21	1610	1	76	25	0,65	17215021	052-21	21	1610	3	-	25,5	1,01		
	17115022	-	051-22	22	1610	1	76	25	0,72	17215022	052-22	22	1610	3	-	25,5	1,18		
	17115023	18115023	051-23	23	1610	1	76	25	0,77	17215023	052-23	23	1610	3	-	25,5	1,35		
	17115024	-	051-24	24	2012	1	90	32	0,98	17215024	052-24	24	2012	2	90	32	1,45		
	17115025	18115025	051-25	25	2012	1	90	32	1,05	17215025	052-25	25	2012	2	90	32	1,55		
	17115026	-	051-26	26	2012	1	85	32	1,11	17215026	052-26	26	2012	2	90	32	1,75		
	17115027	18115027	051-27	27	2012	1	90	32	1,17	17215027	052-27	27	2012	2	90	32	1,98		
	17115028	-	051-28	28	2012	1	90	32	1,29	17215028	052-28	28	2012	2	90	32	2,03		
	17115030	18115030	051-30	30	2012	1	90	32	1,40	17215030	052-30	30	2012	2	90	32	2,63		
	17115038	-	051-38	38	2012	1	102	32	2,43	17215038	052-38	38	2517	2	108	45	3,10		
17115045	-	051-45	45	2012	1	111	32	3,55	17215045	052-45	45	2517	7	110	45	4,00			
17115057	-	051-57	57	2012	6	111	32	4,28	17215057	052-57	57	2517	7	124	45	5,88			
17115076	-	051-76	76	2012	6	111	32	5,95	17215076	052-76	76	3020	7	160	51	9,90			
17115095	-	051-95	95	2517	6	124	45	7,50	17215095	052-95	95	3020	7	160	51	12,80			
17115114	-	051-114	114	2517	6	124	45	11,20	17215114	052-114	114	3020	7	160	51	16,50			
3/4" 19,05 mm	17119013	18119013	061-13	13	1210	1	63	25	0,35										
	17119014	-	061-14	14	1610	1	71	25	0,40	17219014	062-14	14	1610	3	-	30,3	0,60		
	17119015	18119015	061-15	15	1610	1	71	25	0,44	17219015	062-15	15	1610	3	-	30,3	0,68		
	17119016	-	061-16	16	1610	1	75	25	0,53	17219016	062-16	16	1610	3	-	30,3	0,89		
	17119017	18119017	061-17	17	1610	1	76	25	0,66	17219017	062-17	17	1610	3	-	30,3	1,14		
	17119018	-	061-18	18	2012	1	90	32	0,86	17219018	062-18	18	2012	2	89	32	1,18		
	17119019	18119019	061-19	19	2012	1	90	32	0,94	17219019	062-19	19	2012	2	95	32	1,24		
	17119020	-	061-20	20	2012	1	90	32	1,04	17219020	062-20	20	2517	2	108	45	1,40		
	17119021	18119021	061-21	21	2517	1	102	45	1,24	17219021	062-21	21	2517	2	108	45	1,68		
	17119022	-	061-22	22	2517	1	102	45	1,60	17219022	062-22	22	2517	2	108	45	1,99		
	17119023	18119023	061-23	23	2517	1	108	45	1,70	17219023	062-23	23	2517	2	108	45	2,24		
	17119024	-	061-24	24	2517	1	108	45	1,81	17219024	062-24	24	2517	2	108	45	2,54		
	17119025	18119025	061-25	25	2517	1	108	45	1,93	17219025	062-25	25	2517	2	108	45	2,87		
	17119026	-	061-26	26	2517	1	108	45	2,04	17219026	062-26	26	2517	2	108	45	3,17		
	17119027	18119027	061-27	27	2517	1	108	45	2,14	17219027	062-27	27	2517	2	108	45	3,55		
	17119028	-	061-28	28	2517	1	108	45	2,37	17219028	062-28	28	2517	2	108	45	4,10		
	17119030	18119030	061-30	30	2517	1	108	45	2,60	17219030	062-30	30	2517	2	108	45	4,62		
	17119038	-	061-38	38	2517	1	124	45	3,93	17219038	062-38	38	3020	2	152	51	8,11		
17119045	-	061-45	45	2517	1	124	45	5,54	17219045	062-45	45	3020	7	154	51	9,00			
17119057	-	061-57	57	2517	6	124	45	6,48	17219057	062-57	57	3020	7	160	51	10,28			
17119076	-	061-76	76	2517	6	124	45	9,71	17219076	062-76	76	3020	7	160	51	15,24			
17119095	-	061-95	95	2517	6	124	45	12,20	17219095	062-95	95	3020	7	160	51	20,00			
17119114	-	061-114	114	2525	6	124	63	16,80	17219114	062-114	114	3030	7	160	76	25,00			

CAD drawings available on our site
www.chiaravalli.com

Quantity, availability and prices
on B2B Chiaravalli

TAPER LOCK® CHAIN SPROCKETS



TAPER LOCK® CHAIN SPROCKETS

MATERIAL **STEEL**
C 45 UNI 5007

AVAILABLE ALSO
WITH INDUCTION
HARDENED TEETH

MATERIAL **IN CAST IRON**
GG20 UNI 5007

Hardened teeth HRC 45÷53

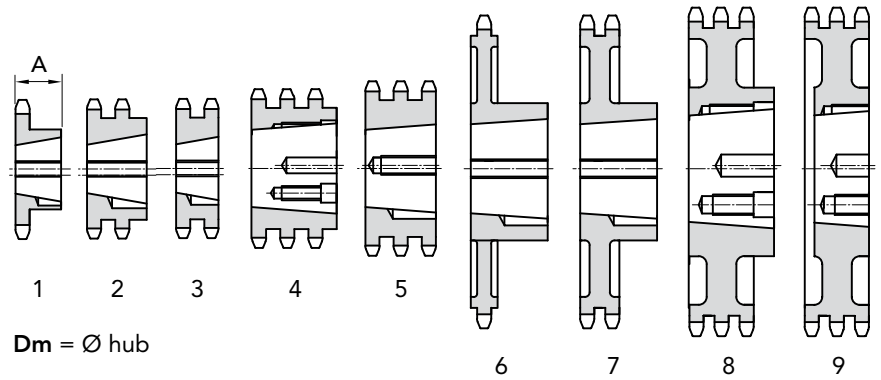

PITCH	SIMPLEX										DUPLEX						
	P.NUMBER	P.NUMBER	COD.	Z	for	Exec.	Dm	A	Kg	P.NUMBER	COD.	Z	for	Exec.	Dm	A	Kg
25,40 mm	ACCIAIO	TEMPRATI	PITCH	taper	bush	Type	hub			PITCH	taper	bush	Type	hub			
	17125013	-	081-13	13	1610	1	78	25	0,98	17225013	082-13	13	1610	3	-	47,7	1,70
	17125014	-	081-14	14	1610	1	78	25	1,14	17225014	082-14	14	1610	3	-	47,7	1,90
	17125015	18125015	081-15	15	1610	1	78	25	1,30	17225015	082-15	15	2012	3	-	47,7	2,11
	17125016	-	081-16	16	2012	1	90	32	1,40	17225016	082-16	16	2517	3	-	47,7	2,25
	17125017	18125017	081-17	17	2012	1	90	32	1,59	17225017	082-17	17	2517	3	-	47,7	2,53
	17125018	-	081-18	18	2517	1	108	45	2,10	17225018	082-18	18	2517	3	-	47,7	3,10
	17125019	18125019	081-19	19	2517	1	108	45	2,29	17225019	082-19	19	2517	3	-	47,7	3,50
	17125020	-	081-20	20	2517	1	108	45	2,60	17225020	082-20	20	2517	3	-	47,7	4,10
	17125021	18125021	081-21	21	2517	1	108	45	2,81	17225021	082-21	21	3020	2	143	51	4,15
	17125022	-	081-22	22	2517	1	108	45	3,10	17225022	082-22	22	3020	2	150	51	4,90
	17125023	18125023	081-23	23	2517	1	108	45	3,38	17225023	082-23	23	3020	2	160	51	5,69
	17125024	-	081-24	24	2517	1	108	45	3,70	17225024	082-24	24	3020	2	166	51	6,00
	17125025	18125025	081-25	25	2517	1	108	45	3,97	17225025	082-25	25	3020	2	175	51	6,38
	17125026	-	081-26	26	2517	1	108	45	4,26	17225026	082-26	26	3020	2	175	51	7,80
	17125027	18125027	081-27	27	2517	1	108	45	4,55	17225027	082-27	27	3020	2	175	51	9,27
	17125028	-	081-28	28	2517	1	108	45	5,26	17225028	082-28	28	3020	2	175	51	11,4
	17125030	18125030	081-30	30	3020	1	160	51	5,97	17225030	082-30	30	3020	2	175	51	13,5
	17125038	-	081-38	38	3020	1	160	51	8,73	17225038	082-38	38	3030	7	160	76	13,8
	17125045	-	081-45	45	3020	1	160	51	12,49	17225045	082-45	45	3030	7	160	76	17,4
	17125057	-	081-57	57	3020	6	160	51	13,87	17225057	082-57	57	3535	7	175	89	22,4
	17125076	-	081-76	76	3020	6	160	51	22,63	17225076	082-76	76	3535	7	175	89	33,2
	17125095	-	081-95	95	3020	6	160	51	32,00	17225095	082-95	95	4040	7	215	102	52,5
	17125114	-	081-114	114	3030	6	150	76	50,00	17225114	082-114	114	4040	7	215	102	80,0
1" 1/4	17131015	18131015	081-15	15	2517	1	108	45	3,39								
31,75 mm	17131017	18131017	081-17	17	2517	1	108	45	5,07								
	17131019	18131019	081-19	19	2517	1	108	45	6,75								
	17131021	18131021	081-21	21	2517	1	108	45	7,70								
	17131023	18131023	081-23	23	2517	1	108	45	8,78								
	17131025	18131025	081-25	25	2517	1	108	45	9,50								
	17131030	18131030	081-30	30	3020	1	160	51	15,90								
	17131038	-	081-38	38	3020	6	160	51	12,80								
	17131045	-	081-45	45	3020	6	160	51	14,50								
	17131057	-	081-57	57	3020	6	160	51	18,40								
	17131076	-	081-76	76	3020	6	160	51	28,90								
	17131095	-	081-95	95	3030	6	160	76	40,50								
	17131114	-	081-114	114	4040	6	240	102	54,00								



CAD drawings available on our site
www.chiaravalli.com

Quantity, availability and prices
on B2B Chiaravalli



TAPER LOCK® CHAIN SPROCKETS

MATERIAL **STEEL**
C 45 UNI 5007

MATERIAL **IN CAST IRON**
GG20 UNI 5007

Hardened teeth HRC 45÷53

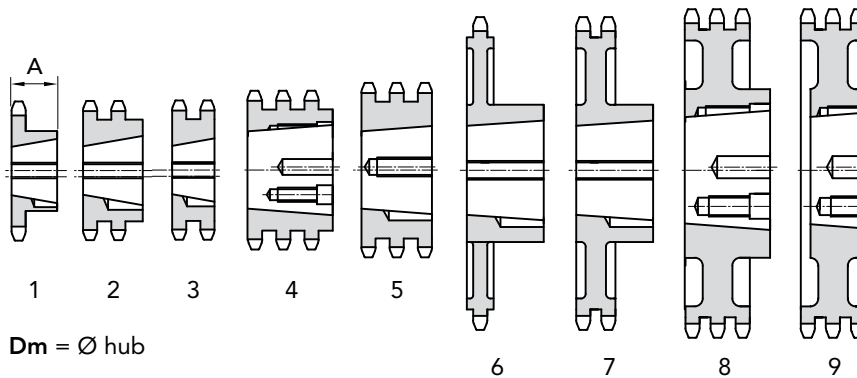

TRIPLEX

PITCH	P.NUMBER	COD.	Z	for	Exec.	Dm	A	Kg
		PITCH	taper bush	Type	hub			
3/4" 19,05 mm	17319015	063-15	15	1615	5	-	49,8	1,11
	17319017	063-17	17	2012	5	-	49,8	1,75
	17319019	063-19	19	2012	5	-	49,8	2,02
	17319021	063-21	21	2517	5	-	49,8	2,49
	17319023	063-23	23	2517	5	-	49,8	3,00
	17319025	063-25	25	2517	5	-	49,8	3,98
	17319027	063-27	27	3020	4	140	51	3,90
	17319030	063-30	30	3020	4	140	51	5,64
	17319038	063-38	38	3020	4	140	51	11,58
	17319045	063-45	45	3020	4	159	51	12,11
	17319057	063-57	57	3020	8	160	51	11,40
	17319076	063-76	76	3020	8	160	51	17,20
	17319095	063-95	95	3030	8	160	76	27,60
	17319114	063-114	114	3030	8	160	76	35,00
1" 25,40 mm	17325017	083-17	17	2517	5	-	79,6	4,29
	17325019	083-19	19	3020	5	-	79,6	4,36
	17325021	083-21	21	3020	5	-	79,6	6,69
	17325023	083-23	23	3525	5	-	79,6	7,80
	17325025	083-25	25	3525	5	-	79,6	10,93
	17325027	083-27	27	3525	5	-	79,6	14,06
	17325030	083-30	30	3525	5	-	79,6	19,10
	17325038	083-38	38	3535	8	178	89,0	19,50
	17325045	083-45	45	4040	8	216	102	29,80
	17325057	083-57	57	4040	8	216	102	38,50
	17325076	083-76	76	4040	8	216	102	53,75
	17325095	083-95	95	4040	8	240	102	80,80
	17325114	083-114	114	4545	8	260	114	120,00



CAD drawings available on our site
www.chiaravalli.com

Quantity, availability and prices
on B2B Chiaravalli



3/8" x 7/32"
CHAIN SPROCKETS

Tooth radius r_3	10	mm
Radius width C	1	mm
Sprockets tooth width B_1 (S)	5,3	mm
Sprockets tooth width b_1 (D-T)	5,2	mm
Sprockets tooth width B_2 (D)	15,4	mm
Sprockets tooth width B_3 (T)	25,6	mm

CHAIN

Pitch	9,525	mm
Inner width	5,72	mm
Roller \varnothing	6,35	mm

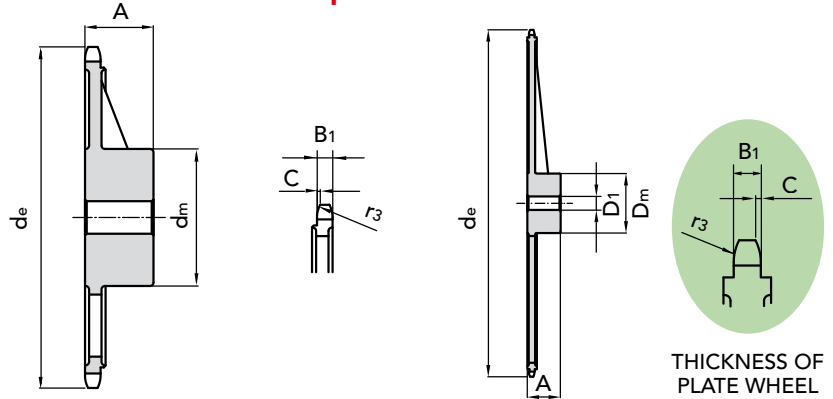
for roller chains in compliance with DIN 8187 ISO/R 606



SIMPLEX								DUPLEX				TRIPLEX					
Z	de	dp	PART NUMBER	dm	D1	A	kg.	PART NUMBER	dm	D1	A	kg.	PART NUMBER	dm	D1	A	kg.
38	119,5	115,35	12109038	70	20	32	1,12	12209038	80	24	40	1,90	12309038	90	24	56	3,00
45	140,7	136,55	12109045	70	20	32	1,30	12209045	80	24	40	2,06	12309045	90	24	56	3,56
57	176,9	172,91	12109057	70	20	32	1,55	12209057	80	24	40	2,30	12309057	90	24	56	3,97
76	234,9	230,49	12109076	70	20	32	2,00	12209076	80	24	40	3,02	12309076	100	24	56	4,52
95	292,5	288,08	12109095	80	20	40	3,83	12209095	90	24	45	4,68	12309095	100	24	56	6,12
114	349,6	345,68	12109114	80	20	40	4,05	12209114	95	24	45	5,90	12309114	100	24	56	10,00
150	459,2	454,82	12109150	90	21	45	4,05	12209150	100	24	50	5,90	12309150	125	24	60	9,00

1/2" x 5/16"
CHAIN SPROCKETS

Tooth radius r_3	13	mm
Radius width C	1,3	mm
Sprockets tooth width B_1 (S)	7,2	mm
Sprockets tooth width b_1 (D-T)	7	mm
Sprockets tooth width B_2 (D)	21	mm
Sprockets tooth width B_3 (T)	34,9	mm

CHAIN

Pitch	12,7	mm
Inner width	7,75	mm
Roller \varnothing	8,51	mm

for roller chains in compliance with DIN 8187 ISO/R 606

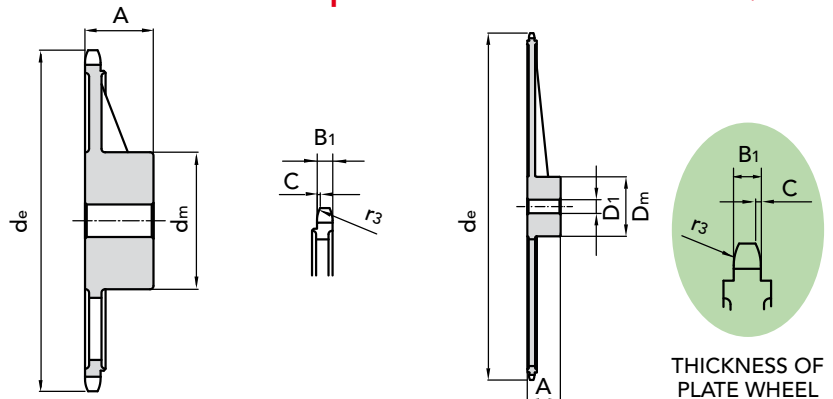

SIMPLEX								DUPLEX				TRIPLEX					
Z	de	dp	PART NUMBER	dm	D1	A	kg.	PART NUMBER	dm	D1	A	kg.	PART NUMBER	dm	D1	A	kg.
38	158,6	153,8	12112038	70	20	40	1,56	12212038	90	24	50	3,15	12312038	100	24	60	4,45
45	188,0	182,0	12112045	70	20	40	1,95	12212045	90	24	50	3,56	12312045	100	24	60	5,85
57	236,4	230,54	12112057	70	20	40	2,46	12212057	90	24	50	4,00	12312057	100	24	60	6,28
76	313,3	307,33	12112076	80	24	40	4,20	12212076	100	24	56	6,35	12312076	100	24	60	8,60
95	390,1	384,11	12112095	80	24	45	5,45	12212095	100	24	56	8,00	12312095	120	24	67	11,9
114	466,9	460,9	12112114	91	24	45	8,35	12212114	100	24	63	11,9	12312114	120	24	67	15,0

We do not manufacture SPROCKETS in cast iron version ASA

SIMPLE CHAIN SPROCKETS WITH DUPLEX REINFORCE

CAD drawings available on our site
www.chiaravalli.com

Quantity, availability and prices on B2B Chiaravalli





5/8" x 3/8"

for roller chains in compliance with DIN 8187 ISO/R 606

CHAIN SPROCKETS

Tooth radius r_3	16	mm
Radius width C	1,6	mm
Sprockets tooth width B_1 (S)	9,1	mm
Sprockets tooth width b_1 (D-T)	9	mm
Sprockets tooth width B_2 (D)	25,5	mm
Sprockets tooth width B_3 (T)	42,1	mm

CHAIN

Pitch	15,875	mm
Inner width	9,65	mm
Roller \varnothing	10,16	mm

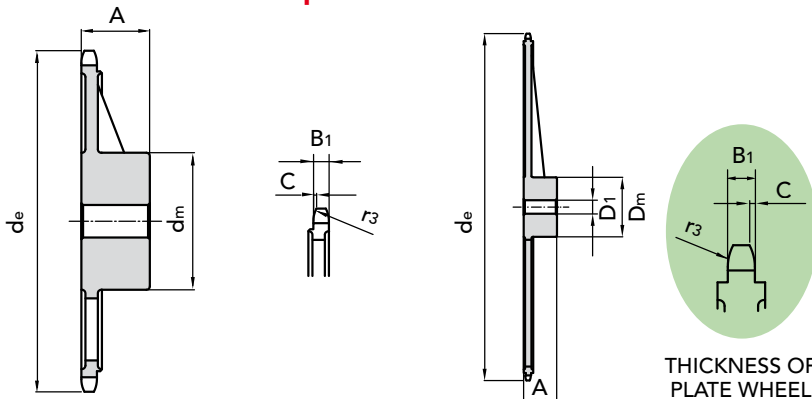

SIMPLEX

DUPLEX

TRIPLEX

Z	d _e	d _p	PART NUMBER	d _m	D ₁	A	kg.	PART NUMBER	d _m	D ₁	A	kg.	PART NUMBER	d _m	D ₁	A	kg.
38	199,2	192,24	12115038	80	20	40	2,32	12215038	100	30	50	4,56	12315038	100	32	60	6,50
45	235	227,58	12115045	80	20	40	2,88	12215045	100	30	50	4,93	12315045	100	32	60	7,04
57	296	288,18	12115057	90	24	45	4,30	12215057	100	30	56	6,50	12315057	100	32	63	8,00
76	392,1	384,16	12115076	90	24	50	7,00	12215076	100	30	63	9,10	12315076	110	35	67	12,0
95	488,5	480,14	12115095	100	24	56	10,65	12215095	110	30	63	12,6	12315095	125	35	70	19,4
114	584,1	576,13	12115114	100	24	56	14,50	12215114	125	30	70	17,8	12315114	125	35	80	24,0

3/4" x 7/16"

for roller chains in compliance with DIN 8187 ISO/R 606

CHAIN SPROCKETS

Tooth radius r_3	19	mm
Radius width C	2	mm
Sprockets tooth width B_1 (S)	11,1	mm
Sprockets tooth width b_1 (D-T)	10,8	mm
Sprockets tooth width B_2 (D)	30,3	mm
Sprockets tooth width B_3 (T)	49,8	mm

CHAIN

Pitch	19,05	mm
Inner width	11,68	mm
Roller \varnothing	12,07	mm

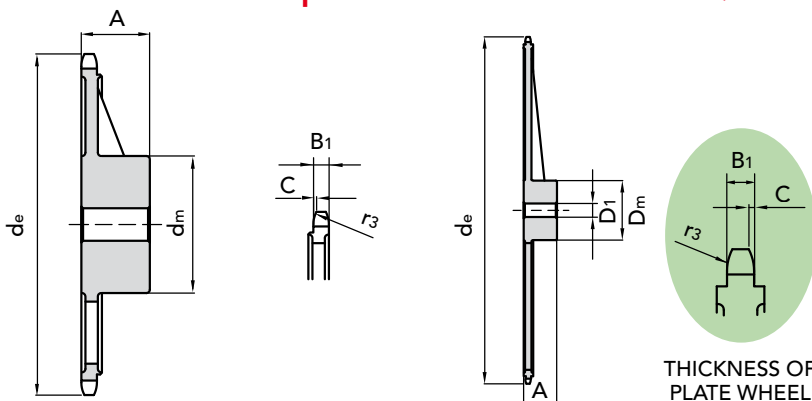

SIMPLEX

DUPLEX

TRIPLEX

Z	d _e	d _p	PART NUMBER	d _m	D ₁	A	kg.	PART NUMBER	d _m	D ₁	A	kg.	PART NUMBER	d _m	D ₁	A	kg.
38	239	230,69	12119038	100	24	56	4,75	12219038	110	24	63	7,50	12319038	140	31	70	10,00
45	282,5	273,1	12119045	100	24	56	5,90	12219045	110	24	63	8,30	12319045	140	31	70	13,30
57	354	345,81	12119057	100	30	56	6,45	12219057	120	30	63	10,3	12319057	140	39	70	15,25
76	469,9	460,99	12119076	100	30	56	12,30	12219076	135	30	63	15,2	12319076	160	39	75	27,20
95	585,1	576,17	12119095	100	30	56	15,40	12219095	135	30	70	21,2	12319095	170	39	82	36,40
114	700,6	691,36	12119114	100	30	56	24,80	12219114	135	30	70	30,4	12319114	170	49	82	41,10

We do not manufacture SPROCKETS in cast iron version ASA

SIMPLE CHAIN SPROCKETS WITH DUPLEX REINFORCE

CAD drawings available on our site www.chiaravalli.com

Quantity, availability and prices on B2B Chiaravalli



CHAIN SPROCKETS IN CAST IRON GG 20 UNI 5007 for roller chains in compliance with DIN 8187 ISO/R 606



1" x 17.02 mm
CHAIN SPROCKETS

Tooth radius r_3	26	mm
Radius width C	2,5	mm
Sprockets tooth width B_1	16,2	mm
Sprockets tooth width b_1	15,8	mm
Sprockets tooth width B_2	47,7	mm
Sprockets tooth width B_3	79,6	mm

CHAIN

Pitch	25,4	mm
Inner width	17,02	mm
Roller \varnothing	5,88	mm

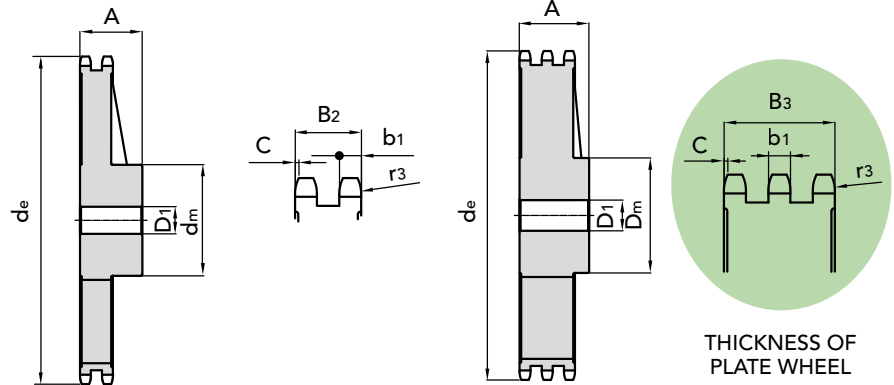
for roller chains in compliance with DIN 8187 ISO/R 606



THICKNESS OF PLATE WHEEL

SIMPLEX
DUPLEX
TRIPLEX

Z	d _e	d _p	PART NUMBER	d _m	D ₁	A	kg.	PART NUMBER	d _m	D ₁	A	kg.	PART NUMBER	d _m	D ₁	A	kg.
30	254	243	12125030	110	29	65	7,00	12225030	125	39	75	13,30	12325030	145	39	90	20,00
38	320	307,59	12125038	110	29	65	8,26	12225038	140	39	75	16,45	12325038	160	44	100	25,40
45	377	364,13	12125045	125	29	70	10,75	12225045	150	39	75	19,20	12325045	160	44	100	33,60
57	474	461,08	12125057	125	34	70	12,90	12225057	170	39	90	29,50	12325057	165	44	100	44,70
76	627	614,65	12125076	140	34	80	24,70	12225076	175	39	95	46,30	12325076	200	44	110	63,10
95	781	768,22	12125095	140	39	80	32,00	12225095	175	44	95	53,00	12325095	200	49	110	77,00
114	933	921,81	12125114	150	39	80	45,50	12225114	175	44	95	74,00	12325114	200	49	115	97,00

1" 1/4 x 3/4"
CHAIN SPROCKETS

Tooth radius r_3	32	mm
Radius width C	3,5	mm
Sprockets tooth width B_1	18,5	mm
Sprockets tooth width b_1	18,2	mm
Sprockets tooth width B_2	54,6	mm
Sprockets tooth width B_3	91	mm

CHAIN

Pitch	31,75	mm
Inner width	19,56	mm
Roller \varnothing	19,05	mm

for roller chains in compliance with DIN 8187 ISO/R 606

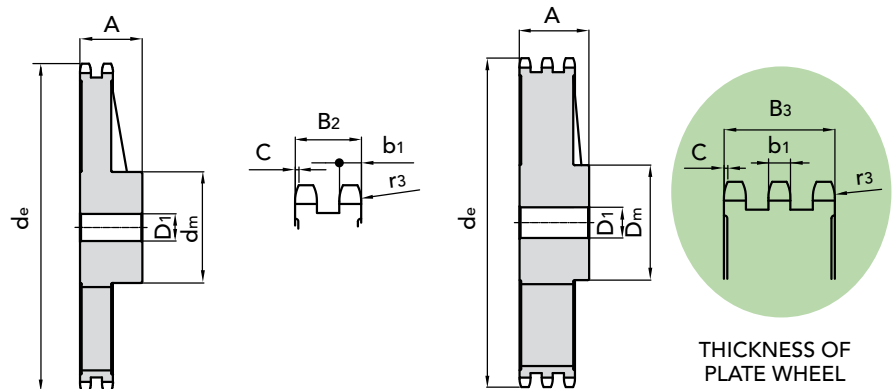

THICKNESS OF PLATE WHEEL

SIMPLEX
DUPLEX
TRIPLEX

Z	d _e	d _p	PART NUMBER	d _m	D ₁	A	kg.	PART NUMBER	d _m	D ₁	A	kg.	PART NUMBER	d _m	D ₁	A	kg.
30	318,9	303,75	12131030	115	34	70	8,50	12231030	130	39	80	22,00					
38	399,6	384,49	12131038	125	34	70	12,30	12231038	140	44	90	24,80	12331038	170	55	110	52,00
45	470,3	455,17	12131045	125	34	70	18,00	12231045	140	44	90	32,00					
57	591,5	576,36	12131057	135	39	80	25,60	12231057	160	49	100	43,00	12331057	180	62	125	71,50
76	783,5	768,32	12131076	140	49	90	29,10	12231076	180	55	100	62,50					

We do not manufacture SPROCKETS in cast iron version ASA

SIMPLE CHAIN SPROCKETS WITH DUPLEX REINFORCE

 CAD drawings available on our site
www.chiaravalli.com

 Quantity, availability and prices
 on B2B Chiaravalli



1" 1/2 x 1"

CHAIN SPROCKETS

Tooth radius r_3	38	mm
Radius width C	4	mm
Sprockets tooth width B_1	24,1	mm
Sprockets tooth width b_1	23,6	mm
Sprockets tooth width B_2	72	mm
Sprockets tooth width B_3	120,3	mm

CHAIN

Pitch	38,1	mm
Inner width	25,4	mm
Roller \varnothing	25,4	mm

for roller chains in compliance with DIN 8187 ISO/R 606

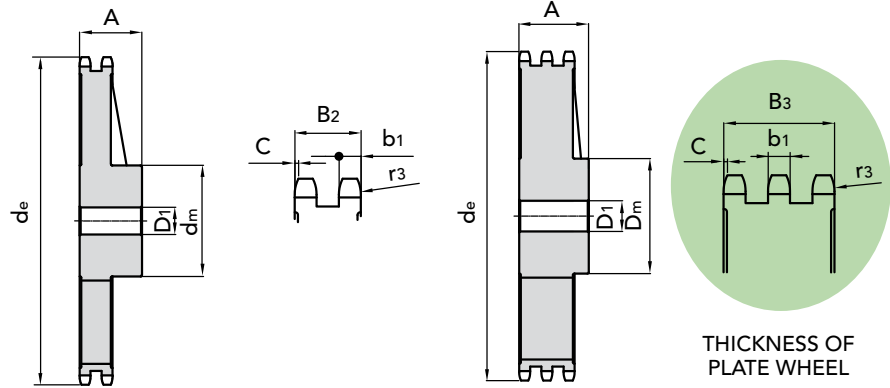

SIMPLEX

DUPLEX

TRIPLEX

Z	d_e	d_p	PART NUMBER	d_m	D_1	A	kg.	PART NUMBER	d_m	D_1	A	kg.	PART NUMBER	d_m	D_1	A	kg.	
30	379,5	364,5	12138030	130	39	85	18,50											
38	476,2	461,39	12138038	140	44	90	21,80	12238038	180	44	100	42,20	12338038	200	62	150	42,50	
45	561,2	546,2	12138045	140	44	90	30,00											
57	706,5	691,63	12138057	160	44	100	46,20	12238057	200	54	110	72,70	12338057	200	62	150	119,40	
76	936,9	921,98	12138076	170	44	100	63,60	12238076	220	54	120	125,00	12338076	250	69	150	150,00	

We do not manufacture SPROCKETS in cast iron version ASA

CAD drawings available on our site www.chiaravalli.com

Quantity, availability and prices on B2B Chiaravalli



CHAIN SPROCKETS IN CAST IRON GG 20 UNI 5007 for roller chains in compliance with DIN 8187 ISO/R 606

CHAIN SPROCKETS FOR CONVEYORS AND ELEVATORS



CHAIN SPROCKETS P50 R 25 - 31

CHAIN

Pitch	50	mm
Inner width	11,5	mm
Roller Ø	25	mm
Plate thickness B ₁	10,5	mm

CHAIN

Pitch	50	mm
Inner width	15	mm
Roller Ø	31	mm
Plate thickness B ₁	13,8	mm

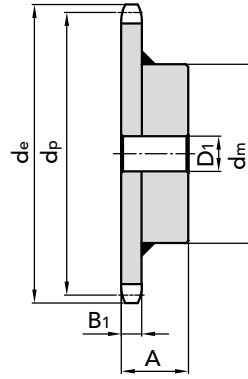

CHAIN SPROCKETS P50

ROLLER 25

ROLLER 31

Z	d _e	d _p	PART NUMBER	D ₁	d _m	A	kg.	PART NUMBER	d _e	d _p	D ₁	d _m	A	kg.
6	115,0	100,0	14502506	20	60	40,5	1,11	14503106	116,2	100	20	60	43,8	1,18
7	132,7	115,24	14502507	20	60	40,5	1,37	14503107	133,8	115,24	20	60	43,8	1,44
8	148,1	130,6	14502508	20	60	40,5	1,55	14503108	152,3	130,6	20	60	43,8	1,72
9	163,7	146,2	14502509	20	60	40,5	1,89	14503109	167,9	146,2	20	60	43,8	2,05
10	179,3	161,85	14502510	25	90	43,3	3,10	14503110	183,5	161,85	25	90	46,6	4,40
11	195,0	177,5	14502511	25	90	43,3	3,44	14503111	199,2	177,5	25	90	46,6	3,80
12	211,0	193,2	14502512	25	90	43,3	4,79	14503112	212,0	193,2	25	90	46,6	4,30
13	226,4	208,95	14502513	30	90	43,3	4,17	14503113	230,6	208,95	30	90	46,6	4,78
14	242,2	224,7	14502514	30	90	43,3	4,63	14503114	246,4	224,7	30	90	46,6	5,37
15	257,9	240,45	14502515	30	90	43,3	5,09	14503115	262,1	240,45	30	90	46,6	5,98
16	273,8	456,3	14502516	30	110	55,4	8,26	14503116	278,0	256,3	30	110	58,7	9,05
17	289,5	272,05	14502517	30	110	55,4	9,10							
18	305,4	287,95	14502518	30	110	55,4	9,26	14503118	309,6	287,95	30	110	58,7	10,30
19								14503119	325,5	303,8	30	110	58,7	11,10
20	337,1	319,6	14502520	30	110	55,4	10,42	14503120	341,3	319,6	30	110	58,7	11,90
21	352,9	335,45	14502521	30	110	55,4	11,71							
22								14503122	373,0	351,35	30	110	58,7	13,54
23								14503123	388,9	367,2	30	110	58,7	14,38
24	400,0	383,05	14502524	30	110	55,4	13,00	14503124	404,7	383,05	30	110	58,7	15,35
25	416,4	398,95	14502525	30	110	55,4	13,98	14503125	419,7	398,95	30	110	58,7	16,40
26	432,3	414,8	14502526	30	133	61,1	15,20	14503126	436,5	414,8	30	133	64,4	18,81
27	448,2	430,7	14502527	30	133	61,1	17,03	14503127	452,4	430,7	30	133	64,4	19,00
28	464,0	446,55	14502528	30	133	61,1	18,62	14503128	468,2	446,55	30	133	64,4	21,00
30	495,8	478,35	14502530	30	133	61,1	20,29							
32								14503132	531,8	510,1	30	133	64,4	25,93
35								14503135	579,5	557,8	30	133	64,4	28,40
38	622,9	605,45	14502538	30	133	61,1	26,97	14503138	622	605,45	30	133	64,4	32,10

ALL THE CHAIN SPROCKETS FOR TRANSPORTERS AND ELEVATORS ARE REALIZED WITH WELDED HUB.

CAD drawings available on our site
www.chiaravalli.com

Quantity, availability and prices
 on B2B Chiaravalli



CHAIN SPROCKETS FOR CONVEYORS AND ELEVATORS

CHAIN SPROCKETS FOR CONVEYORS AND ELEVATORS

CHAIN SPROCKETS P75 R 31

CHAIN

Pitch	75	mm
Inner width	15	mm
Roller Ø	31	mm
Plate thickness B ₁	13,8	mm

CHAIN SPROCKETS P75 ROLLER 31

Z	d _e	d _p	PART NUMBER	D ₁	d _m	A	kg.
8	217,6	195,98	14753108	30	90	46,6	4,52
9	241	219,3	14753109	30	90	46,6	5,36
10	264,4	242,77	14753110	30	110	58,7	8,70
11	287,9	266,25	14753111	30	110	58,7	9,60
12	311,5	289,8	14753112	30	110	58,7	10,73
13	334,1	313,42	14753113	30	110	58,7	11,83
14	358,7	337,05	14753114	30	110	58,7	11,83
15	382,3	360,67	14753115	30	110	58,7	14,45
16	406,1	384,45	14753116	30	133	64,4	17,43
17	429,7	408,07	14753117	30	133	64,4	17,43
21	524,8	503,17	14753121	30	133	64,4	26,07
25	620,1	598,42	14753125	30	133	64,4	26,07

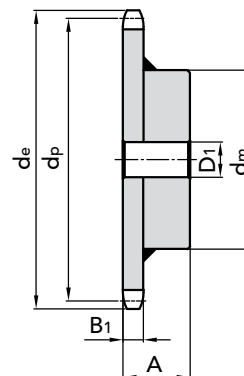

CHAIN SPROCKETS P100 R 31 - 40

CHAIN

Pitch	100	mm
Inner width	15	mm
Roller Ø	31	mm
Plate thickness B ₁	13,8	mm

CHAIN

Pitch	100	mm
Inner width	22	mm
Roller Ø	40	mm
Plate thickness B ₁	20	mm

ALL THE CHAIN SPROCKETS FOR TRANSPORTERS AND ELEVATORS ARE REALIZED WITH WELDED HUB.

CHAIN SPROCKETS P100 ROLLER 31

ROLLER 40

Z	d _e	d _p	PART NUMBER	D ₁	d _m	A	kg.	PART NUMBER	d _e	d _p	D ₁	d _m	A	kg.
8	282,9	261,31	14993108	30	110	58,7	9,67	14994008	283	261,31	30	110	65	11,97
9	314,1	292,4	14993109	30	110	58,7	10,95	14994009	314	292,4	30	110	65	14,04
10	345,4	323,61	14993110	30	110	58,7	12,63	14994010	345	323,61	30	110	65	16,35
11	376,7	354,95	14993111	30	110	58,7	12,14	14994011	378	354,95	30	110	65	18,82
12	408,1	386,4	14993112	30	110	58,7	16,51	14994012	409	386,4	30	110	65	21,58
13	439,6	417,9	14993113	30	110	58,7	18,51							
14								14994014	473	449,4	30	110	65	28,14
15														
16	534,3	512,6	14993116	30	133	64,4	27,16	14994016	536	512,6	30	133	70,6	33,87
17	565,8	544,1	14993117	30	133	64,4	30,01							
18	597,6	575,9	14993118	30	133	64,4	51,20							
19														
20								14994020	663	639,2	30	133	70,6	48,50

CAD drawings available on our site
www.chiaravalli.com

Quantity, availability and prices
 on B2B Chiaravalli

WITH BEARING
INA KRR-AH02-C5

Our chain tensioning sprockets are supplied complete with bearing, ready for assembly in special tension or transmission points. The accurate machining and stable assembly on a dual protective shield ball bearing ensure greater resistance to loads and wear. The central elongated ring of the bearing facilitates assembly on special machines of every type.

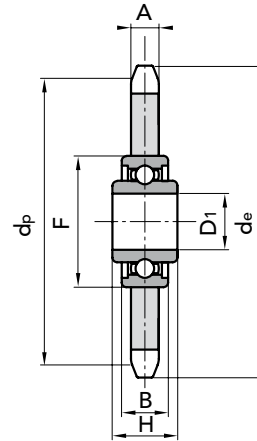

Z	PITCH	d _e	d _p	PART NUMBER	A	D1	F	B	H	kg.
23	8 x 3	62,15	58,75	30008123	2,8	16 ^{+0,26 +0,13}	40	12	18,3	0,13
21	3/8" x 7/32"	68,00	63,90	30009121	5,3	16 ^{+0,26 +0,13}	40	12	18,3	0,15
18	1/2" x 1/8"	78,90	73,14	30010118	3,0	16 ^{+0,26 +0,13}	40	12	18,3	0,18
18	1/2" x 3/16"	78,90	73,13	30011118	4,5	16 ^{+0,26 +0,13}	40	12	18,3	0,20
16	1/2" x 5/16"	69,50	65,10	30012116	7,2	16 ^{+0,26 +0,13}	40	12	18,3	0,17
18	1/2" x 5/16"	77,80	73,14	30012118	7,2	16 ^{+0,26 +0,13}	40	12	18,3	0,22
14	5/8" x 3/8"	78,00	71,34	30015114	9,1	16 ^{+0,26 +0,13}	40	12	18,3	0,23
15	5/8" x 3/8"	83,00	76,36	30015115	9,1	16 ^{+0,26 +0,13}	40	12	18,3	0,27
17	5/8" x 3/8"	93,00	86,39	30015117	9,1	16 ^{+0,26 +0,13}	40	12	18,3	0,36
13	3/4" x 7/16"	87,50	79,59	30019113	11,1	16 ^{+0,26 +0,13}	40	12	18,3	0,34
15	3/4" x 7/16"	99,80	91,63	30019115	11,1	16 ^{+0,26 +0,13}	40	12	18,3	0,47
12	1" x 17.02	109,00	98,14	30025112	16,2	20 ^{+0 +0,1}	47	14	17,7	0,72
13	1"1/4 x 3/4"	147,80	132,65	30031113	18,5	25 ^{+0 +0,1}	52	15	21,0	1,64

CAD drawings available on our site
www.chiaravalli.com5

Quantity, availability and prices
 on B2B Chiaravalli





WITH ECONOMIC BEARING

Our chain tensioning sprockets are supplied complete with bearing, ready for assembly in special tension or transmission points. The accurate machining and stable assembly on a dual protective shield ball bearing ensure greater resistance to loads and wear. The central elongated ring of the bearing facilitates assembly on special machines of every type.

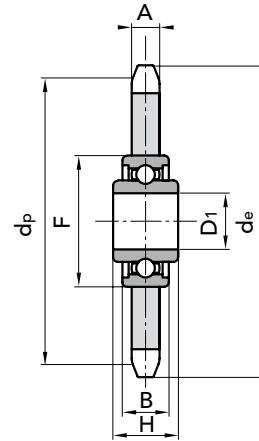
**IDLER SPROCKET**

Z	PITCH	d _e	d _p	PART NUMBER	A	D1	F	B	H	kg.
23	8 x 3	62,15	58,75	30008023	2,8	16 $\begin{smallmatrix} +0,26 \\ +0,13 \end{smallmatrix}$	40	12	18,3	0,13
21	3/8" x 7/32"	68,00	63,90	30009021	5,3	16 $\begin{smallmatrix} +0,26 \\ +0,13 \end{smallmatrix}$	40	12	18,3	0,15
22	3/8" x 7/32"	71,00	66,93	30009022	5,3	16 $\begin{smallmatrix} +0,26 \\ +0,13 \end{smallmatrix}$	40	12	18,3	0,16
18	1/2" x 1/8"	78,90	73,14	30010018	3,0	16 $\begin{smallmatrix} +0,26 \\ +0,13 \end{smallmatrix}$	40	12	18,3	0,18
15	1/2" x 3/16"	66,80	61,09	30011015	4,5	16 $\begin{smallmatrix} +0,26 \\ +0,13 \end{smallmatrix}$	40	12	18,3	0,16
16	1/2" x 3/16"	70,90	65,10	30011016	4,5	16 $\begin{smallmatrix} +0,26 \\ +0,13 \end{smallmatrix}$	40	12	18,3	0,17
18	1/2" x 3/16"	78,90	73,13	30011018	4,5	16 $\begin{smallmatrix} +0,26 \\ +0,13 \end{smallmatrix}$	40	12	18,3	0,20
14	1/2" x 5/16"	61,80	57,07	30012014	7,2	16 $\begin{smallmatrix} +0,26 \\ +0,13 \end{smallmatrix}$	40	12	18,3	0,13
16	1/2" x 5/16"	69,50	65,10	30012016	7,2	16 $\begin{smallmatrix} +0,26 \\ +0,13 \end{smallmatrix}$	40	12	18,3	0,17
18	1/2" x 5/16"	77,80	73,14	30012018	7,2	16 $\begin{smallmatrix} +0,26 \\ +0,13 \end{smallmatrix}$	40	12	18,3	0,22
14	5/8" x 3/8"	78,00	71,34	30015014	9,1	16 $\begin{smallmatrix} +0,26 \\ +0,13 \end{smallmatrix}$	40	12	18,3	0,23
15	5/8" x 3/8"	83,00	76,36	30015015	9,1	16 $\begin{smallmatrix} +0,26 \\ +0,13 \end{smallmatrix}$	40	12	18,3	0,27
17	5/8" x 3/8"	93,00	86,39	30015017	9,1	16 $\begin{smallmatrix} +0,26 \\ +0,13 \end{smallmatrix}$	40	12	18,3	0,36
13	3/4" x 7/16"	87,50	79,59	30019013	11,1	16 $\begin{smallmatrix} +0,26 \\ +0,13 \end{smallmatrix}$	40	12	18,3	0,34
15	3/4" x 7/16"	99,80	91,63	30019015	11,1	16 $\begin{smallmatrix} +0,26 \\ +0,13 \end{smallmatrix}$	40	12	18,3	0,47
12	1" x 17.02	109,00	98,14	30025012	16,2	20 $\begin{smallmatrix} +0 \\ +0,1 \end{smallmatrix}$	47	14	17,7	0,72
13	1"1/4 x 3/4"	147,80	132,65	30031013	18,5	25 $\begin{smallmatrix} +0 \\ +0,1 \end{smallmatrix}$	52	15	21,0	1,64



Quantity, availability and prices
on B2B Chiaravalli



PLATEWHEELS

ISO PLATEWHEELS	page 4
ASA PLATEWHEELS	30
DUPLEX PLATEWHEELS FOR TWO SIMPLEX CHAIN	39
DUPLEX PLATEWHEELS FOR TWO SIMPLEX CHAIN TAPER LOCK [®]	41
PLATEWHEELS FOR CONVEYORS AND ELEVATORS	43

WHEELS FOR TABLE TOP CHAINS

WHEELS FOR TABLE TOP CHAINS	47
---------------------------------------	----

HUBS and ADAPTORS

WELDED HUBS	51
WELDED HUBS FOR TAPER BUSHES	52
REMOVABLE HUBS FOR TAPER BUSHES	53
REMOVABLE HUBS FOR PLATEWHEELS	54
ADAPTORS FOR TAPER BUSHES	55



PLATEWHEELS





The range of platewheels designed for chains manufactured by our Company provides an all-round solution to the needs of industry in the sector of flexible mechanical transmissions and is the result of a manufacturing process that is designed to achieve the top in terms of technical and quality performance.

Our production programme includes sprockets and wheels designed for chains, produced in compliance with the principles and with the most recent Standards and International Unified Standards: UNI, ISO, DIN, ANSI, etc.

However, the standards define a profile with minimum dimensions and a profile with maximum dimensions for the wheel space for chains and rollers and the actual profile must lie within these values.

There is the option of selecting proportioning criteria for the profile, since the tolerances that the Standards leave to the manufacturer's discretion are quite wide. The profiles can be optimised in terms of smooth transmission and the tooth's capacity to support greater stresses. This has led to the systematic development of a series of standardised profiles for which the geometry can be reproduced with great precision by tools designed specifically by computer and the reference profile of which is protected by the Company's knowhow.

A valued feature of this optimised profile, which is a characteristic exclusive to CHIARAVALLI GROUP SpA, is that of enhancing the "polygonal" chain wrap-around on the sprocket and on the platewheel, reproducing the motion discontinuity which is achieved even in the case of unfavourable transmission ratios and centre distances.

As a result of this CHIARAVALLI GROUP SpA has been able to include sprockets with a very low number of teeth in its catalogue and production programme.

Respecting precision with limited machining errors is beneficial, even if the toothed wheel-chain set represents a somewhat "basic" transmission solution.

This precision is assured by the systematic use of CNC machines and technologies developed to minimise the shearing stress and to improve the degree of surface finish. The sprockets and wheels designed for chains included in the catalogue are also manufactured in the version with the "Taperlock" taper bush piece system particularly favoured in applications that require easy assembly and very precise centring tolerances.

Our sales programme is completed with single and multiple roller chains, and special chains suitable for every industrial application and CHIARAVALLI GROUP SpA is also able to manufacture sprockets and platewheels suitable for chains in a specific execution, produced to drawing any of material and with induction hardening and case-hardening and hardening applied to steel wheels and sprockets.



PLATEWHEELS 5 x 2.5 mm for roller chains in compliance with DIN 8187 - ISO/R 606

5 x 2.5 mm

PLATEWHEEL

Tooth radius r_3	5	mm
Radius width $\overset{\circ}{C}$	0,6	mm
Plate tooth width B_1	2,3	mm

CHAIN

Pitch	5	mm
Inner width	2,5	mm
Roller \varnothing	3,2	mm

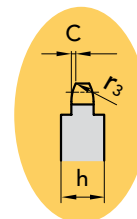
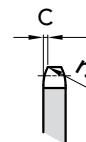
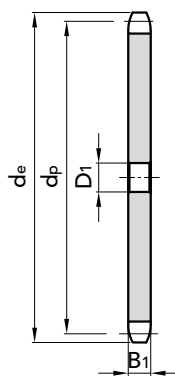

SIMPLEX

Z	D ₁	d _e	d _p	P. NUMBER	kg.	Z	D ₁	d _e	d _p	P. NUMBER	kg.
8	4	15,2	13,06	20105008	0,01	52	10	85,0	82,81	20105052	0,17
9	4	16,8	14,62	20105009	0,01	55	10	89,7	87,58	20105055	0,18
10	4	18,3	16,18	20105010	0,01	56	10	91,3	89,17	20105056	0,19
11	5	19,9	17,75	20105011	0,01	57	10	92,9	90,76	20105057	0,20
12	5	21,5	19,32	20105012	0,01	58	10	94,5	92,35	20105058	0,20
13	5	23,0	20,89	20105013	0,01	59	10	96,1	93,94	20105059	0,21
14	5	24,6	22,47	20105014	0,01	60	10	97,7	95,53	20105060	0,23
15	5	26,2	24,04	20105015	0,01	62	12	100,9	98,72	20105062	0,24
16	6	27,8	25,63	20105016	0,01	64	12	104,1	101,90	20105064	0,27
17	6	29,4	27,20	20105017	0,01	65	12	105,6	103,49	20105065	0,28
18	6	30,9	28,79	20105018	0,01	66	12	107,2	105,08	20105066	0,31
19	6	32,5	30,38	20105019	0,01	70	12	113,6	111,44	20105070	0,36
20	6	34,1	31,96	20105020	0,01	75	12	121,6	119,40	20105075	0,37
21	8	35,7	33,54	20105021	0,01	76	12	123,1	120,99	20105076	0,41
22	8	37,3	35,13	20105022	0,02	80	12	129,5	127,35	20105080	0,46
23	8	38,9	36,72	20105023	0,02	85	14	137,5	135,31	20105085	0,52
24	8	40,5	38,30	20105024	0,02	90	14	145,4	143,27	20105090	0,58
25	8	42,0	39,89	20105025	0,02	95	14	153,4	151,22	20105095	0,65
26	8	43,6	41,48	20105026	0,02	100	14	161,3	159,18	20105100	0,79
27	8	45,2	43,07	20105027	0,02	114	14	183,6	181,46	20105114	0,85
28	8	46,8	44,65	20105028	0,03	120	14	193,2	191,01	20105120	0,95
30	8	50,0	47,83	20105030	0,03	125	14	201,1	198,96	20105125	1,03
32	8	53,2	51,01	20105032	0,03						
33	8	54,8	52,60	20105033	0,04						
34	8	56,3	54,19	20105034	0,04						
35	8	57,9	55,78	20105035	0,04						
36	8	59,5	57,37	20105036	0,04						
37	8	61,1	58,96	20105037	0,05						
38	8	62,7	60,54	20105038	0,05						
40	8	65,9	63,73	20105040	0,05						
42	8	69,1	66,91	20105042	0,06						
44	8	72,2	70,09	20105044	0,07						
45	8	73,8	71,68	20105045	0,07						
46	8	75,4	73,27	20105046	0,07						
48	8	78,6	76,45	20105048	0,08						
50	8	81,8	79,63	20105050	0,08						

From Z.52 the width of the disk wheel increased to $h = 4\text{mm}$

MATERIAL **FE / C45**

Ask for specific needs.

CAD drawings available on our site
www.chiaravalli.com

Quantity, availability and prices
 on B2B Chiaravalli





PLATEWHEELS

6 x 2.8 mm

PLATEWHEEL

Tooth radius r_3	6	mm
Radius width C	0,7	mm
Plate tooth width B_1	2,6	mm

CHAIN

Pitch	6	mm
Inner width	2,8	mm
Roller \varnothing	4	mm

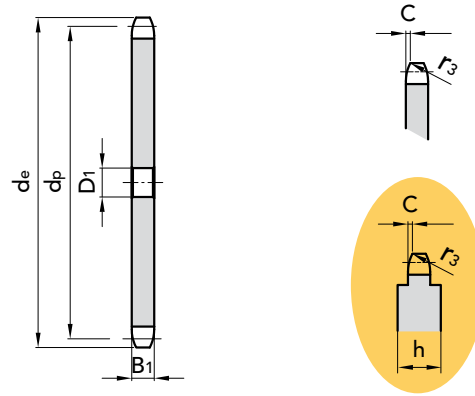

SIMPLEX

Z	D ₁	d _e	d _p	P. NUMBER	kg.	Z	D ₁	d _e	d _p	P. NUMBER	kg.
8	5	18,0	15,67	20106008	0,01	52	12	101,8	99,37	20106052	0,25
9	5	19,9	17,54	20106009	0,01	54	12	105,6	103,17	20106054	0,26
10	6	21,7	19,42	20106010	0,01	55	12	107,6	105,08	20106055	0,27
11	6	23,6	21,30	20106011	0,01	56	12	109,5	109,50	20106056	0,28
12	8	25,4	23,18	20106012	0,01	57	12	111,4	111,40	20106057	0,29
13	8	27,3	25,05	20106013	0,01	58	12	113,3	113,30	20106058	0,30
14	8	29,2	26,96	20106014	0,01	60	12	117,1	117,10	20106060	0,33
15	8	31,0	28,86	20106015	0,01	62	14	120,9	120,90	20106062	0,35
16	8	33,0	30,76	20106016	0,01	64	14	124,7	124,70	20106064	0,37
17	8	35,0	32,65	20106017	0,01	65	14	126,6	126,60	20106065	0,38
18	8	36,9	34,55	20106018	0,02	66	14	128,5	128,50	20106066	0,40
19	8	38,8	36,44	20106019	0,02	70	14	136,2	136,20	20106070	0,45
20	8	40,7	38,34	20106020	0,02	75	16	145,7	145,70	20106075	0,48
21	8	42,6	40,25	20106021	0,02	76	16	147,6	147,60	20106076	0,53
22	8	44,5	42,16	20106022	0,02	80	16	155,3	155,30	20106080	0,59
23	8	46,4	44,06	20106023	0,03	85	16	164,8	164,80	20106085	0,67
24	8	48,3	45,96	20106024	0,03	90	16	174,4	174,40	20106090	0,77
25	8	50,2	47,87	20106025	0,03	95	16	183,9	183,90	20106095	0,85
26	8	52,1	49,76	20106026	0,03	100	16	193,5	193,50	20106100	0,94
27	8	54,0	51,67	20106027	0,04	114	16	220,2	220,20	20106114	1,23
28	8	55,9	53,58	20106028	0,04	120	16	231,7	231,70	20106120	1,37
30	8	59,8	57,42	20106030	0,05	125	16	241,2	238,75	20106125	1,48
32	8	63,6	61,21	20106032	0,05						
33	8	65,5	63,11	20106033	0,06						
34	8	67,4	65,02	20106034	0,06						
35	8	69,3	66,93	20106035	0,07						
36	8	71,2	68,84	20106036	0,07						
37	8	73,1	70,75	20106037	0,07						
38	8	75,0	72,66	20106038	0,08						
40	8	78,9	76,47	20106040	0,09						
42	10	82,7	80,28	20106042	0,10						
44	10	86,6	84,10	20106044	0,11						
45	10	88,5	86,01	20106045	0,11						
46	10	90,4	87,92	20106046	0,12						
48	10	94,2	91,74	20106048	0,13						
50	10	98,0	95,55	20106050	0,14						

PLATEWHEELS 6 x 2.8 mm for roller chains in compliance with DIN 8187 - ISO/R 606

From Z.52 the width of the disk wheel increased to $h = 4mm$

MATERIAL **FE / C45**

Ask for specific needs.

CAD drawings available on our site
www.chiaravalli.com

Quantity, availability and prices
 on B2B Chiaravalli





PLATEWHEELS 1/4" x 1/8" for roller chains in compliance with DIN 8188 - ASA 25 - ISO/R 606 - ANSI B 29 1

1/4" x 1/8" ASA 25

PLATEWHEEL

Tooth radius r_3	6,4	mm
Radius width $\overset{\circ}{C}$	0,7	mm
Plate tooth width B_1	2,9	mm

CHAIN

Pitch	6,35	mm
Inner width	3,18	mm
Roller \varnothing	3,3	mm

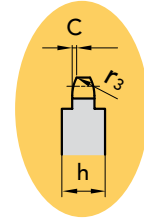
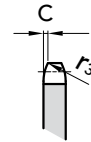
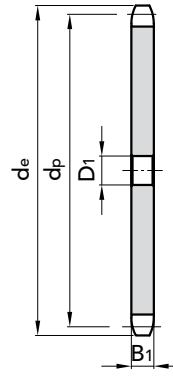

SIMPLEX

Z	D ₁	d _e	d _p	P. NUMBER	kg.	Z	D ₁	d _e	d _p	P. NUMBER	kg.
8	6	19,4	16,58	20107008	0,005	52	12	108,0	105,16	20107052	0,260
9	6	21,4	18,56	20107009	0,005	54	12	112,0	109,18	20107054	0,294
10	6	23,3	20,55	20107010	0,006	55	12	114,0	111,23	20107055	0,296
11	8	25,3	22,54	20107011	0,008	56	12	116,0	113,25	20107056	0,310
12	8	27,3	24,53	20107012	0,010	57	12	118,1	115,27	20107057	0,320
13	8	29,3	26,53	20107013	0,013	58	12	120,1	117,29	20107058	0,330
14	8	31,3	28,53	20107014	0,013	60	12	124,1	121,32	20107060	0,360
15	8	33,3	30,53	20107015	0,013	62	12	128,2	125,37	20107062	0,390
16	8	35,3	32,55	20107016	0,016	64	12	132,2	129,41	20107064	0,420
17	8	37,3	34,55	20107017	0,017	65	12	134,2	131,43	20107065	0,430
18	8	39,4	36,56	20107018	0,021	66	14	136,2	133,45	20107066	0,440
19	8	41,4	38,58	20107019	0,023	70	14	144,3	141,53	20107070	0,505
20	8	43,4	40,58	20107020	0,026	75	14	154,4	151,63	20107075	0,580
21	8	45,4	42,60	20107021	0,028	76	14	156,5	153,66	20107076	0,590
22	8	47,4	44,62	20107022	0,030	80	16	164,5	161,74	20107080	0,660
23	8	49,4	46,63	20107023	0,038	85	16	174,6	171,85	20107085	0,750
24	8	51,4	48,64	20107024	0,038	90	16	184,7	181,95	20107090	0,840
25	8	53,5	50,66	20107025	0,040	95	16	194,8	192,05	20107095	0,940
26	8	55,5	52,67	20107026	0,040	100	16	204,9	202,15	20107100	1,050
27	8	57,5	54,69	20107027	0,045	110	16	225,1	222,37	20107110	1,280
28	8	59,5	56,71	20107028	0,056	114	16	233,2	230,45	20107114	1,380
30	8	63,6	60,75	20107030	0,060	120	16	245,4	242,58	20107120	1,530
32	10	67,6	64,78	20107032	0,060	125	16	255,5	252,68	20107125	1,660
33	10	69,6	66,80	20107033	0,070						
34	10	71,6	68,82	20107034	0,070						
35	10	73,6	70,84	20107035	0,080						
36	10	75,6	72,85	20107036	0,085						
37	10	77,7	74,87	20107037	0,090						
38	10	79,7	76,89	20107038	0,095						
40	10	83,7	80,93	20107040	0,110						
42	10	87,8	84,97	20107042	0,117						
44	10	91,8	89,01	20107044	0,120						
45	10	93,8	91,03	20107045	0,135						
46	10	95,8	93,05	20107046	0,140						
48	10	99,9	97,09	20107048	0,150						
50	10	103,9	101,13	20107050	0,170						

From Z.52 the width of the disk wheel increased to $h = 4\text{mm}$

MATERIAL **FE / C45**

Ask for specific needs.

CAD drawings available on our site
www.chiaravalli.com

Quantity, availability and prices
 on B2B Chiaravalli





PLATEWHEELS

8 x 3 mm

PLATEWHEEL

Tooth radius r_3	8	mm
Radius width C	1,0	mm
Plate tooth width B_1	2,8	mm
Plate tooth width b_1	2,7	mm
Plate tooth width B_2	8,3	mm

CHAIN

Pitch	8	mm
Inner width	3	mm
Roller \varnothing	5	mm

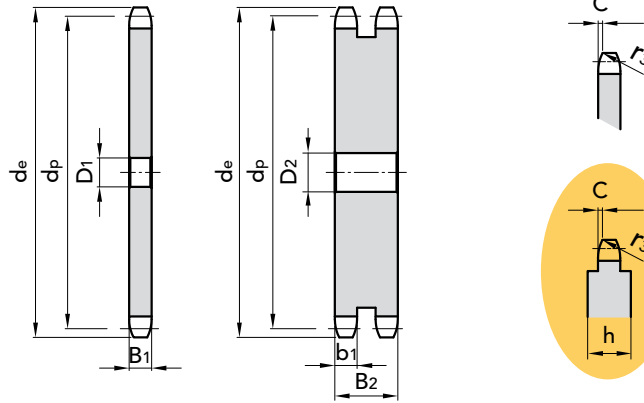

PLATEWHEELS 8 x 3 mm
for roller chains in compliance
with DIN 8187 - ISO/R 606

SIMPLEX

DUPLEX

Z	D ₁	d _e	d _p	P. NUMBER	kg.	Z	D ₁	d _e	d _p	P. NUMBER	kg.	Z	D ₁	d _e	d _p	P. NUMBER	kg.	Z	D ₁	d _e	d _p	P. NUMBER	kg.	
8	6	24,0	20,90	20108008	0,01	45	12	118,0	114,69	20108045	0,32	8	6	24,00	20,90	20208008	0,010	45	14	118,00	114,69	20208045	0,600	
9	6	26,6	23,39	20108009	0,01	46	12	120,6	117,23	20108046	0,34	9	6	26,60	23,39	20208009	0,010	46	14	120,60	117,23	20208046	0,630	
10	8	29,2	25,89	20108010	0,02	47	12	123,1	119,77	20108047	0,35	10	8	29,20	25,89	20208010	0,020	47						
11	8	31,7	28,39	20108011	0,01	48	12	125,6	122,32	20108048	0,37	11	8	31,70	28,39	20208011	0,020	48	14	125,60	122,32	20208048	0,690	
12	8	34,2	30,91	20108012	0,02	50	12	130,7	127,41	20108050	0,40	12	8	34,20	30,91	20208012	0,030	50	14	130,70	127,41	20208050	0,750	
13	8	36,7	33,42	20108013	0,02	51	14	133,3	129,95	20108051	0,42	13	8	36,70	33,42	20208013	0,045	51						
14	8	39,2	35,95	20108014	0,02	52	14	135,8	132,49	20108052	0,43	14	8	39,20	35,95	20208014	0,050	52	16	135,80	132,49	20208052	0,810	
15	8	41,7	38,48	20108015	0,02	54	14	140,9	137,59	20108054	0,47	15	8	41,70	38,48	20208015	0,060	54	16	140,90	137,59	20208054	0,880	
16	8	44,3	41,01	20108016	0,03	55	14	143,5	140,13	20108055	0,49	16	10	44,30	41,01	20208016	0,070	55	16	143,50	140,13	20208055	0,920	
17	8	46,8	43,53	20108017	0,03	56	14	146,0	142,68	20108056	0,51	17	10	46,80	43,53	20208017	0,080	56	16	146,00	142,68	20208056	0,950	
18	8	49,3	46,07	20108018	0,04	57	14	148,6	145,22	20108057	0,53	18	10	49,30	46,07	20208018	0,090	57	16	148,60	145,22	20208057	0,990	
19	8	51,9	48,61	20108019	0,04	58	14	151,0	147,77	20108058	0,55	19	10	51,90	48,61	20208019	0,100	58						
20	8	54,4	51,14	20108020	0,05	59	14	153,6	150,31	20108059	0,57	20	10	54,40	51,14	20208020	0,110	59						
21	8	57,0	53,68	20108021	0,05	60	14	156,2	152,85	20108060	0,59	21	10	57,00	53,68	20208021	0,120	60	16	156,20	152,85	20208060	1,100	
22	8	59,5	56,21	20108022	0,06	62	16	162,0	157,95	20108062	0,63	22	10	59,50	56,21	20208022	0,140	62						
23	8	62,0	58,75	20108023	0,06	64	16	167,1	163,04	20108064	0,67	23	10	62,00	58,75	20208023	0,150	64	20	167,10	163,04	20208064	1,250	
24	8	64,6	61,29	20108024	0,07	65	16	169,6	165,58	20108065	0,69	24	10	64,60	61,29	20208024	0,170	65	20	169,60	165,58	20208065	1,300	
25	8	67,5	63,83	20108025	0,07	66	16	172,2	168,13	20108066	0,77	25	10	67,50	63,83	20208025	0,180	66						
26	10	69,5	66,37	20108026	0,08	70	16	182,4	178,31	20108070	0,81	26	12	69,50	66,37	20208026	0,200	70	20	182,40	178,31	20208070	1,510	
27	10	72,2	68,91	20108027	0,08	75	20	195,1	191,04	20108075	0,93	27	12	72,20	68,91	20208027	0,210	75						
28	10	74,8	71,45	20108028	0,09	76	20	197,7	193,59	20108076	0,94	28	12	74,80	71,45	20208028	0,230	76	20	197,70	193,59	20208076	1,800	
29	10	77,3	73,99	20108029	0,09	80	20	207,9	203,77	20108080	1,01	29	12	77,30	73,99	20208029	0,250	80	20	207,90	203,77	20208080	2,000	
30	10	79,8	76,53	20108030	0,10	85	20	220,6	216,50	20108085	1,20	30	12	79,80	76,53	20208030	0,270	85	20	220,60	216,50	20208085	2,600	
31	10	82,4	79,08	20108031	0,11	90	20	233,4	229,23	20108090	1,35	31	12	82,40	79,08	20208031	0,310	90						
32	10	84,9	81,61	20108032	0,13	95	20	246,1	241,96	20108095	1,51	32	12	84,90	81,61	20208032	0,330	95	20	246,10	241,96	20208095	2,900	
33	10	87,5	84,16	20108033	0,13	100	20	258,9	254,68	20108100	1,68	33	12	87,50	84,16	20208033	0,350	100						
34	10	90,0	86,70	20108034	0,14	114	20	294,5	290,33	20108114	2,20	34	12	90,00	86,70	20208034	0,350	114	20	294,50	290,33	20208114	4,150	
35	10	92,5	89,25	20108035	0,15	120	20	310,0	305,61	20108120	2,44	35	12	92,50	89,25	20208035	0,370	120						
36	10	95,0	91,79	20108036	0,15	125	20	322,5	318,34	20108125	2,65	36	12	95,00	91,79	20208036	0,370	125						
37	10	97,6	94,33	20108037	0,15							37												
38	10	100,2	96,88	20108038	0,16							38	12	100,20	96,88	20208038	0,420							
39	10	102,7	99,42	20108039	0,17							39	12	102,70	99,42	20208039	0,440							
40	10	105,3	101,97	20108040	0,20							40	12	105,30	101,97	20208040	0,470							
41	12	107,8	104,51	20108041	0,25							41												
42	12	110,4	107,05	20108042	0,27							42	14	110,40	107,05	20208042	0,520							
44	12	115,5	112,14	20108044	0,30							44	14	115,50	112,14	20208044	0,570							

From Z.46 the width of the disk wheel increased to $h = 4\text{mm}$

MATERIAL **FE / C45**

Ask for specific needs.

CAD drawings available on our site
www.chiaravalli.com

Quantity, availability and prices
on B2B Chiaravalli

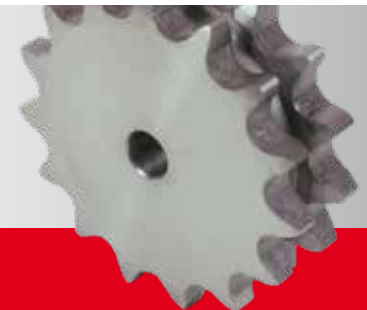

PLATEWHEELS



PLATEWHEELS 3/8" x 7/32"
for roller chains in compliance
with DIN 8187 - ISO/R 606

3/8" x 7/32"

PLATEWHEEL

Tooth radius r_3	10	mm
Radius width \bar{C}	1	mm
Plate tooth width B_1	5,3	mm
Plate tooth width b_1	5,2	mm
Plate tooth width B_2	15,4	mm
Plate tooth width B_3	25,6	mm

CHAIN

Pitch	9,525	mm
Inner width	5,72	mm
Roller \varnothing	6,35	mm

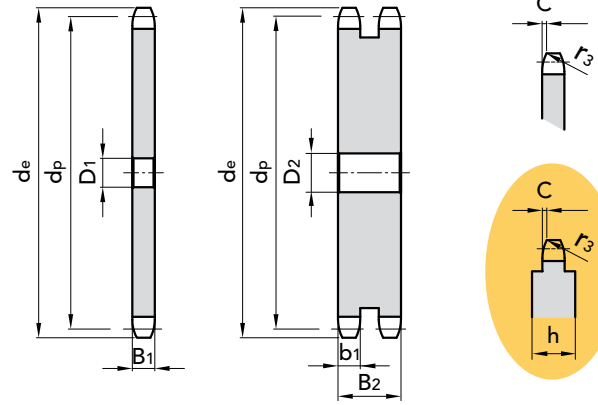

SIMPLEX

Z	D ₁	d _e	d _p	P. NUMBER	kg.
8	6	28,54	24,89	20109008	0,01
9	7	31,50	27,85	20109009	0,01
10	7	34,47	30,82	20109010	0,01
11	8	37,46	33,81	20109011	0,02
12	8	40,45	36,80	20109012	0,02
13	8	43,45	39,80	20109013	0,02
14	8	46,45	42,80	20109014	0,02
15	8	49,46	45,81	20109015	0,02
16	10	52,47	48,82	20109016	0,02
17	10	55,49	51,84	20109017	0,3
18	10	58,50	54,85	20109018	0,03
19	10	61,52	57,87	20109019	0,03
20	10	64,54	60,89	20109020	0,04
21	10	67,56	63,91	20109021	0,04
22	10	70,58	66,93	20109022	0,05
23	10	73,60	69,95	20109023	0,06
24	10	76,62	72,97	20109024	0,07
25	10	79,65	76,00	20109025	0,07
26	10	82,67	79,02	20109026	0,08
27	10	85,70	82,05	20109027	0,09
28	10	88,72	85,07	20109028	0,09
29	10	91,75	88,10	20109029	0,09
30	10	94,77	91,12	20109030	0,1
31	12	97,80	94,15	20109031	0,1
32	12	100,83	97,18	20109032	0,1
33	12	103,85	100,20	20109033	0,12
34	12	106,88	103,23	20109034	0,12
35	12	109,91	106,26	20109035	0,14
36	12	112,94	109,29	20109036	0,14
37	12	115,97	112,32	20109037	0,14
38	12	118,99	115,34	20109038	0,15
39	12	122,02	118,37	20109039	0,16
40	12	125,05	121,40	20109040	0,17
41	16	128,08	124,43	20109041	0,18
42	16	131,11	127,46	20109042	0,2
43	16	134,14	130,49	20109043	0,3
44	16	137,17	133,52	20109044	0,33
45	16	140,20	136,55	20109045	0,35
46	16	143,23	139,58	20109046	0,37
47	16	146,26	142,61	20109047	0,38
48	16	149,29	145,64	20109048	0,39
49	16	152,32	148,67	20109049	0,40
50	16	155,34	151,69	20109050	0,40
51	16	158,37	154,72	20109051	0,41
52	16	161,40	157,75	20109052	0,44
53	16	164,43	160,78	20109053	0,45
54	16	167,47	163,82	20109054	0,46
55	16	170,50	166,85	20109055	0,47
56	16	173,53	169,88	20109056	0,48
57	16	176,56	172,91	20109057	0,50
58	16	179,59	175,94	20109058	0,54
60	16	185,65	182,00	20109060	0,60
62	20	191,71	188,06	20109062	0,61
64	20	197,77	194,12	20109064	0,63
65	20	200,60	197,15	20109065	0,64
66	20	203,83	200,18	20109066	0,65
68	20	209,89	206,24	20109068	0,67
70	20	215,95	212,30	20109070	0,70
72	20	222,02	218,37	20109072	0,80
75	20	231,11	227,46	20109075	0,82
76	20	234,14	230,49	20109076	0,90
78					
80	20	246,26	242,61	20109080	0,95
85	20	261,42	257,77	20109085	1,00
90	20	276,58	272,93	20109090	1,10
95	20	291,73	288,08	20109095	1,50
100	20	306,89	303,24	20109100	1,55
110	20	337,20	333,55	20109110	1,60
114	20	349,33	345,68	20109114	2,00
120	20	367,52	363,87	20109120	2,20
125	20	382,68	379,03	20109125	2,50

DUPLEX

Z	D ₁	d _e	d _p	P. NUMBER	kg.
8	6	28,54	24,89	20209008	0,03
9	8	31,50	27,85	20209009	0,04
10	8	34,47	30,82	20209010	0,05
11	10	37,46	33,80	20209011	0,06
12	10	40,45	36,80	20209012	0,08
13	10	43,45	39,79	20209013	0,10
14	10	46,45	42,80	20209014	0,12
15	10	49,46	45,81	20209015	0,14
16	12	52,47	48,82	20209016	0,16
17	12	55,49	51,83	20209017	0,19
18	12	58,50	54,85	20209018	0,21
19	12	61,30	57,87	20209019	0,24
20	12	64,52	60,89	20209020	0,27
21	12	67,56	63,91	20209021	0,30
22	12	70,58	66,93	20209022	0,34
23	12	73,60	69,95	20209023	0,37
24	12	76,62	72,97	20209024	0,41
25	12	79,65	76,02	20209025	0,45
26	12	82,67	79,02	20209026	0,48
27	12	85,70	82,02	20209027	0,53
28	12	88,72	85,07	20209028	0,57
29	12	91,75	88,09	20209029	0,62
30	12	94,77	91,12	20209030	0,66
31	14	97,80	94,15	20209031	0,71
32	14	100,83	97,17	20209032	0,77
33	14	103,85	100,20	20209033	0,82
34	14	106,88	103,23	20209034	0,87
35	14	109,91	106,26	20209035	0,93
36	14	112,94	109,20	20209036	0,99
37	14	115,97	112,32	20209037	1,05
38	14	118,99	115,35	20209038	1,11
39	14	122,02	118,37	20209039	1,18
40	14	125,05	121,40	20209040	1,24
41	16	128,08	124,43	20209041	1,30
42	16	131,11	127,46	20209042	1,36
43	16	134,14	130,49	20209043	1,44
44	16	137,17	133,52	20209044	1,51
45	16	140,20	136,55	20209045	1,58
46	16	143,23	139,58	20209046	1,66
47	16	146,26	142,61	20209047	1,75
48	16	149,29	145,64	20209048	1,82
49	16	152,32	148,66	20209049	1,90
50	16	155,34	151,69	20209050	1,98
51	16	158,37	154,72	20209051	2,06
52	16	161,40	157,75	20209052	2,15
53	16	164,43	160,78	20209053	2,22
54	16	167,47	163,82	20209054	2,33
55	16	170,50	166,85	20209055	2,42
56	16	173,53	169,88	20209056	2,51
57	16	176,56	172,91	20209057	2,61
58	16	179,59	175,93	20209058	2,71
60	16	185,65	181,99	20209060	2,91
62	20	191,71	188,06	20209062	3,09
64	20	197,77	194,12	20209064	3,30
65	20	200,60	197,15	20209065	3,41
66					
68	20	209,89	206,24	20209068	3,75
70	20	215,95	212,30	20209070	3,99
72	20	222,02	218,37	20209072	4,23
75	20	231,11	227,46	20209075	4,60
76	20	234,14	230,49	20209076	4,73
78	20	241,00	236,55	20209078	4,99
80	20	246,26	242,61	20209080	5,26
85	20	261,42	257,77	20209085	5,96
90	20	276,58	272,93	20209090	6,70
95	20	291,73	288,08	20209095	7,50
100	20	306,89	303,25	20209100	8,34
110	20	337,20	333,55	20209110	10,1
114	20	349,33	345,68	20209114	10,9
120	20	367,52	363,86	20209120	12,11
125	20	382,68	379,02	20209125	13,16

From Z.100 the width of the disk wheel increased to $h = 7\text{mm}$

MATERIAL **FE / C45**

Ask for specific needs.

CAD drawings available on our site
www.chiaravalli.com

Quantity, availability and prices
on B2B Chiaravalli





3/8" x 7/32"

PLATEWHEEL

Tooth radius r_3	10	mm
Radius width C	1	mm
Plate tooth width B_1	5,3	mm
Plate tooth width b_1	5,2	mm
Plate tooth width B_2	15,4	mm
Plate tooth width B_3	25,6	mm

CHAIN

Pitch	9,525	mm
Inner width	5,72	mm
Roller \varnothing	6,35	mm

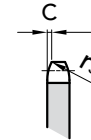
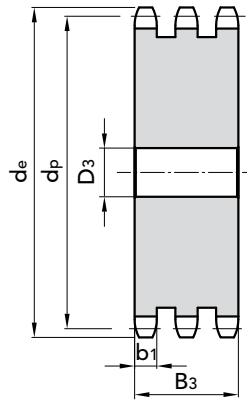

PLATEWHEELS 3/8" x 7/32"
for roller chains in compliance
with DIN 8187 - ISO/R 606

TRIPLEX

Z	D ₁	d _e	d _p	P. NUMBER	kg.	Z	D ₁	d _e	d _p	P. NUMBER	kg.
8	6	28,54	24,89	20309008	0,040	44	16	137,17	133,52	20309044	2,500
9	8	31,50	27,85	20309009	0,060	45	16	140,20	136,55	20309045	2,460
10	10	34,47	30,82	20309010	0,070	46	16	143,23	139,58	20309046	2,750
11	10	37,46	33,80	20309011	0,090	47	16	146,26	142,61	20309047	2,880
12	10	40,45	36,80	20309012	0,122	48	16	149,29	145,64	20309048	3,010
13	10	43,45	39,79	20309013	0,150	49					
14	12	46,45	42,80	20309014	0,186	50	16	155,34	151,69	20309050	3,300
15	12	49,46	45,81	20309015	0,260	51	20	158,37	154,72	20309051	3,430
16	12	52,47	48,82	20309016	0,260	52	20	161,40	157,75	20309052	3,570
17	12	55,49	51,83	20309017	0,340	53					
18	12	58,50	54,85	20309018	0,345	54					
19	12	61,52	57,87	20309019	0,396	55					
20	12	64,54	60,89	20309020	0,445	56	20	173,53	169,88	20309056	4,140
21	14	67,56	63,91	20309021	0,480	57	20	176,56	172,91	20309057	4,300
22	14	70,58	66,93	20309022	0,540	58	20	179,59	175,93	20309058	4,460
23	14	73,60	69,95	20309023	0,600	60	20	185,65	181,99	20309060	4,800
24	14	76,62	72,97	20309024	0,660	62					
25	14	79,65	76,02	20309025	0,730	64	20	197,77	194,12	20309064	5,500
26	14	82,67	79,02	20309026	0,795	65	20	200,60	197,15	20309065	5,670
27	14	85,70	82,02	20309027	0,865	66	25	203,83	200,18	20309066	5,660
28	14	88,72	85,07	20309028	0,940	68					
29	14	91,75	88,09	20309029	1,010	70	25	215,95	212,30	20309070	6,630
30	14	94,77	91,12	20309030	1,090	72	25	222,02	218,37	20309072	7,030
31	16	97,80	94,15	20309031	1,180	75					
32	16	100,83	97,17	20309032	1,260	76	25	234,49	230,49	20309076	7,870
33	16	103,85	100,20	20309033	1,350	78					
34	16	106,88	103,23	20309034	1,440	80	25	246,26	242,61	20309080	8,760
35	16	109,91	106,26	20309035	1,540	85	25	261,42	257,77	20309085	9,930
36	16	112,94	109,20	20309036	1,620	90	25	276,58	272,93	20309090	11,17
37						95	25	291,73	288,08	20309095	12,49
38	16	118,99	115,35	20309038	1,800	100	25	306,89	303,25	20309100	13,89
39						110	25	337,20	333,55	20309110	16,89
40	16	125,05	121,40	20309040	2,030	114	25	349,33	345,68	20309114	18,17
41	20	128,08	124,43	20309041	2,150	120	25	367,52	363,86	20309120	20,18
42	16	131,11	127,46	20309042	2,260	125	25	382,68	379,02	20309125	21,94
43	16	134,14	130,49	20309043	2,380						

MATERIAL **FE / C45**
Ask for specific needs.

CAD drawings available on our site
www.chiaravalli.com

Quantity, availability and prices
on B2B Chiaravalli





1/2" x 1/8"
PLATEWHEEL

Tooth radius r_3	13	mm
Radius width \tilde{C}	1,0	mm
Plate tooth width B_1	3	mm

CHAIN

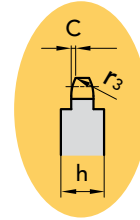
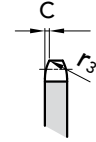
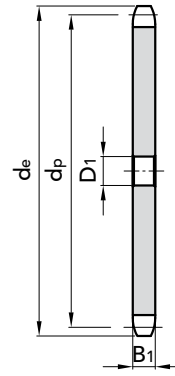
Pitch	12,7	mm
Inner width	3,3	mm
Roller \varnothing	7,75	mm

SIMPLEX

Z	D ₁	d _e	d _p	P. NUMBER	kg.	Z	D ₁	d _e	d _p	P. NUMBER	kg.
8	8	37,2	33,18	20110008	0,02	48	20	199,7	194,18	20110048	0,94
9	8	41,5	37,13	20110009	0,02	50	20	207,8	202,26	20110050	1,06
10	8	46,2	41,10	20110010	0,02	52	20	215,9	210,34	20110052	1,14
11	8	49,6	45,07	20110011	0,03	54	20	224,0	218,43	20110054	1,19
12	8	53,9	49,07	20110012	0,04	55	20	228,0	222,46	20110055	1,25
13	8	58,4	53,06	20110013	0,04	56	20	232,1	226,50	20110056	1,30
14	8	62,8	57,07	20110014	0,05	57	20	236,1	230,54	20110057	1,35
15	8	66,8	61,09	20110015	0,06	58	20	240,2	234,58	20110058	1,45
16	10	70,9	65,10	20110016	0,07	60	20	248,2	242,66	20110060	1,50
17	10	74,9	69,11	20110017	0,08	65	20	268,8	262,86	20110065	1,61
18	10	78,9	73,14	20110018	0,09	66					
19	10	82,9	77,16	20110019	0,10	68	25	280,9	274,99	20110068	1,87
20	10	86,9	81,19	20110020	0,11	70	25	289,0	283,07	20110070	2,05
21	10	91,0	85,22	20110021	0,11	76	25	313,3	307,33	20110076	2,19
22	10	95,0	89,24	20110022	0,13	80	25	329,4	323,48	20110080	2,42
23	10	99,0	93,27	20110023	0,15	90	25	369,9	363,90	20110090	4,53
24	10	103,0	97,29	20110024	0,16	95	25	390,1	384,10	20110095	5,00
25	10	107,1	101,33	20110025	0,17	100	25	410,3	404,31	20110100	5,61
26	12	111,2	105,36	20110026	0,26	114	25	466,9	460,90	20110114	7,42
27	12	115,4	109,40	20110027	0,28	120	25	491,2	486,16	20110120	8,00
28	12	119,4	113,42	20110028	0,32						
29	12	123,4	117,46	20110029	0,33						
30	12	127,5	121,50	20110030	0,35						
32	12	135,5	129,56	20110032	0,40						
33	12	139,6	133,60	20110033	0,43						
34	12	143,6	137,64	20110034	0,46						
35	12	147,6	141,68	20110035	0,49						
36	16	151,7	145,72	20110036	0,51						
37	16	155,7	149,76	20110037	0,55						
38	16	159,8	153,80	20110038	0,58						
39	16	163,8	157,83	20110039	0,61						
40	16	167,8	161,87	20110040	0,64						
42	16	175,4	169,95	20110042	0,69						
44	16	183,5	178,03	20110044	0,79						
45	16	187,5	182,07	20110045	0,82						
46	20	191,6	186,10	20110046	0,88						

From Z.30 the width of the disk wheel increased to $h = 4\text{mm}$

From Z.90 the width of the disk wheel increased to $h = 6\text{mm}$

CAD drawings available on our site
www.chiaravalli.com

Quantity, availability and prices
 on B2B Chiaravalli





1/2" x 3/16"

PLATEWHEEL

Tooth radius r_3	13 mm
Radius width C	1,3 mm
Plate tooth width B_1	$4,3^{\pm 0,2}$ mm

CHAIN

Pitch	12,7 mm
Inner width	4,88 mm
Roller \varnothing	7,75 mm

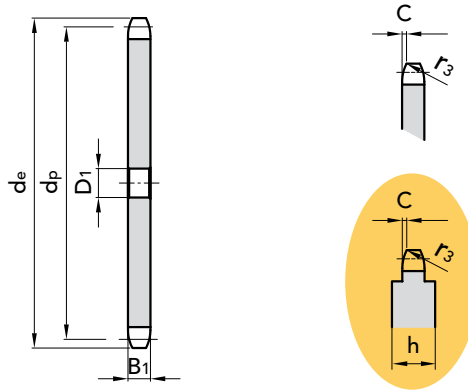

SIMPLEX

Z	D ₁	d _e	d _p	P. NUMBER	kg.	Z	D ₁	d _e	d _p	P. NUMBER	kg.
8	8	38,5	33,18	20111008	0,02	44	16	183,5	178,03	20111044	0,83
9	8	41,5	37,13	20111009	0,03	45	16	187,5	182,07	20111045	0,87
10	8	46,2	41,10	20111010	0,04	46	20	191,6	186,10	20111046	0,91
11	8	49,6	45,07	20111011	0,05	47	20	195,6	190,14	20111047	0,95
12	8	53,9	49,07	20111012	0,05	48	20	199,7	194,18	20111048	0,99
13	8	58,4	53,06	20111013	0,06	49	20	203,7	198,22	20111049	1,04
14	8	62,8	57,07	20111014	0,08	50	20	207,8	202,26	20111050	1,08
15	8	66,8	61,09	20111015	0,09	51	20	211,8	206,30	20111051	1,12
16	10	70,9	65,10	20111016	0,10	52	20	215,9	210,34	20111052	1,17
17	10	74,9	69,11	20111017	0,12	53	20	219,9	214,37	20111053	1,22
18	10	78,9	73,14	20111018	0,13	54	20	224,0	218,43	20111054	1,26
19	10	82,9	77,16	20111019	0,15	55	20	228,0	222,46	20111055	1,31
20	10	86,9	81,19	20111020	0,16	56	20	232,1	226,50	20111056	1,36
21	10	91,0	85,22	20111021	0,18	57	20	236,1	230,54	20111057	1,41
22	10	95,0	89,24	20111022	0,20	58	20	240,2	234,58	20111058	1,46
23	10	99,0	93,27	20111023	0,22	60	20	248,2	242,66	20111060	1,57
24	10	103,0	97,29	20111024	0,24	62	20	256,7	250,75	20111062	1,68
25	10	107,1	101,33	20111025	0,26	64	20	264,8	258,82	20111064	1,80
26	12	111,2	105,36	20111026	0,28	65	20	268,8	262,86	20111065	1,85
27	12	115,4	109,40	20111027	0,30	66					
28	12	119,4	113,42	20111028	0,33	68	25	280,9	274,99	20111068	2,02
29	12	123,4	117,46	20111029	0,35	70	25	289,0	283,07	20111070	2,14
30	12	127,5	121,50	20111030	0,38	72	25	297,1	291,16	20111072	2,27
31	12	131,5	125,54	20111031	0,40	76	25	313,3	307,33	20111076	2,54
32	12	135,5	129,56	20111032	0,43	78					
33	12	139,6	133,60	20111033	0,46	80					
34	12	143,6	137,64	20111034	0,49	85	25	349,7	343,70	20111085	3,19
35	12	147,6	141,68	20111035	0,52	90	25	369,9	363,90	20111090	3,86
36	16	151,7	145,72	20111036	0,55	95	25	390,1	384,10	20111095	4,95
37	16	155,7	149,76	20111037	0,58	100	25	410,3	404,31	20111100	5,83
38	16	159,8	153,80	20111038	0,62	110	25	450,7	444,74	20111110	7,07
39	16	163,8	157,83	20111039	0,65	114	25	466,9	460,90	20111114	7,61
40	16	167,8	161,87	20111040	0,68	120	25	491,2	485,16	20111120	8,50
41	16	171,4	165,91	20111041	0,72	125	25	511,4	505,37	20111125	9,17
42	16	175,4	169,95	20111042	0,76						
43	16	179,5	173,99	20111043	0,80						

From Z.90 the width of the disk wheel increased to $h = 6$ mm

MATERIAL **FE / C45**

Ask for specific needs.

CAD drawings available on our site
www.chiaravalli.com

Quantity, availability and prices
on B2B Chiaravalli





1/2" x 1/4" roller 7.75
PLATEWHEEL

Tooth radius r_3	13	mm
Radius width \bar{C}	1,3	mm
Plate tooth width B_1	5,9	mm

CHAIN

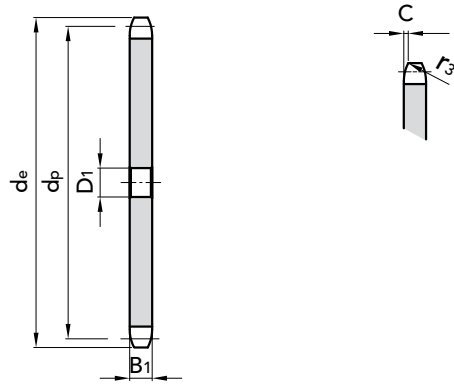
Pitch	12,7	mm
Inner width	6,4	mm
Roller \varnothing	7,75	mm

SIMPLEX

Z	D ₁	d _e	d _p	P. NUMBER	kg.	Z	D ₁	d _e	d _p	P. NUMBER	kg.
8	8	38,5	33,18	20113008	0,030	44	16	183,5	178,03	20113044	1,090
9	8	41,5	37,13	20113009	0,038	45	16	187,5	182,07	20113045	1,150
10	8	46,2	41,10	20113010	0,040	46	20	191,6	186,10	20113046	1,170
11	8	49,6	45,07	20113011	0,059	47	20	195,6	190,14	20113047	1,270
12	8	53,9	49,07	20113012	0,072	48	20	199,7	194,18	20113048	1,380
13	8	58,4	53,06	20113013	0,100	49	20	203,7	198,22	20113049	1,390
14	8	62,8	57,07	20113014	0,100	50	20	207,8	202,26	20113050	1,440
15	8	66,8	61,09	20113015	0,115	52	20	215,9	210,34	20113052	1,620
16	10	70,9	65,10	20113016	0,120	54	20	224,0	218,43	20113054	1,710
17	10	74,9	69,11	20113017	0,150	56	20	232,1	226,50	20113056	1,750
18	10	78,9	73,14	20113018	0,190	57	20	236,1	230,54	20113057	1,850
19	10	82,9	77,16	20113019	0,210	58					
20	10	86,9	81,19	20113020	0,220	60	20	248,2	242,66	20113060	2,120
21	10	91,0	85,22	20113021	0,240	62	20	256,7	250,75	20113062	2,310
22	10	95,0	89,24	20113022	0,240	65	20	268,8	262,86	20113065	2,420
23	10	99,0	93,27	20113023	0,250	70	25	289,0	283,07	20113070	2,950
24	10	103,0	97,29	20113024	0,310	76	25	313,3	307,33	20113076	3,480
25	10	107,1	101,33	20113025	0,310	80	25	329,4	323,48	20113080	3,700
26	12	111,2	105,36	20113026	0,390	85	25	349,7	343,70	20113085	4,370
27	12	115,4	109,40	20113027	0,430	95	25	390,1	384,10	20113095	5,470
28	12	119,4	113,42	20113028	0,440	100	25	410,3	404,31	20113100	5,710
29						110	25	450,7	444,74	20113110	6,000
30	12	127,5	121,50	20113030	0,480	114	25	466,9	460,90	20113114	6,540
31	12	131,5	125,54	20113031	0,560	120					
32	12	135,5	129,56	20113032	0,570	125					
33	12	139,6	133,60	20113033	0,620						
34	12	143,6	137,64	20113034	0,660						
35	12	147,6	141,68	20113035	0,680						
36	16	151,7	145,72	20113036	0,810						
37	16	155,7	149,76	20113037	0,910						
38	16	159,8	153,80	20113038	0,950						
39	16	163,8	157,83	20113039	0,950						
40	16	167,8	161,87	20113040	0,980						
41	16	171,4	165,91	20113041	0,980						
42	16	175,4	169,95	20113042	0,990						
43	16	179,5	173,99	20113043	1,030						

 MATERIAL **FE / C45**

Ask for specific needs.

 CAD drawings available on our site
www.chiaravalli.com

 Quantity, availability and prices
 on B2B Chiaravalli





1/2" x 1/4" roller 8.51

PLATEWHEEL

Tooth radius r_3	13	mm
Radius width \bar{C}	1,3	mm
Plate tooth width B_1	5,9	mm

CHAIN

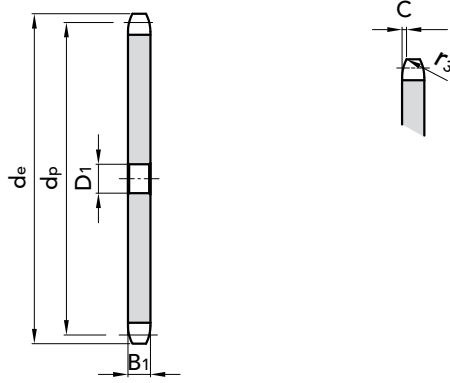
Pitch	12,7	mm
Inner width	6,4	mm
Roller \varnothing	8,51	mm



SIMPLEX

Z	D ₁	d _e	d _p	P. NUMBER	kg.	Z	D ₁	d _e	d _p	P. NUMBER	kg.
8	8	37,2	33,18	20114008	0,020	44					
9	8	41,0	37,13	20114009	0,030	45	16	188,0	182,07	20114045	1,150
10						46					
11	8	48,7	45,07	20114011	0,060	47	20	196,2	190,14	20114047	1,300
12	8	53,0	49,07	20114012	0,080	48					
13	8	57,4	53,06	20114013	0,090	49					
14	8	61,8	57,07	20114014	0,100	50	20	208,3	202,26	20114050	1,410
15						52					
16	10	69,5	65,10	20114016	0,140	54	20	224,1	218,43	20114054	1,720
17	10	73,6	69,11	20114017	0,148	56					
18	10	77,8	73,14	20114018	0,157	57	20	236,4	230,54	20114057	1,930
19	10	81,7	77,16	20114019	0,195	58					
20	10	85,8	81,19	20114020	0,200	60					
21						62	20	256,9	250,75	20114062	2,170
22						65	20	269,0	262,86	20114065	2,370
23	10	98,2	93,27	20114023	0,290	70					
24	10	101,8	97,29	20114024	0,310	76	25	313,3	307,33	20114076	3,310
25	10	105,8	101,33	20114025	0,330	80	25	329,4	323,48	20114080	3,830
26	12	110,0	105,36	20114026	0,360	85					
27	12	114,0	109,40	20114027	0,390	95					
28	12	118,0	113,42	20114028	0,420	100					
29	12	122,0	117,46	20114029	0,480	110	25	450,7	444,74	20114110	9,50
30	12	126,1	121,50	20114030	0,490	114					
31	12	130,2	125,54	20114031	0,550	120					
32	12	134,2	129,56	20114032	0,560	125					
33											
34											
35	12	146,7	141,68	20114035	0,700						
36											
37	16	154,6	149,76	20114037	0,790						
38	16	158,6	153,80	20114038	0,800						
39	16	162,7	157,83	20114039	0,880						
40	16	166,8	161,87	20114040	0,900						
41	16	171,4	165,91	20114041	0,920						
42	16	175,4	169,95	20114042	1,030						
43	16	179,7	173,99	20114043	1,080						

MATERIAL **FE / C45**

Ask for specific needs.

CAD drawings available on our site
www.chiaravalli.com

Quantity, availability and prices
 on B2B Chiaravalli



PLATEWHEELS 1/2" x 1/4" roller 8.51 for roller chains in compliance with DIN 8187 - ISO/R 606



PLATEWHEELS 1/2" x 5/16"
for roller chains in compliance
with DIN 8187 - ISO/R 606

1/2" x 5/16"

PLATEWHEEL

Tooth radius r_3	13	mm
Radius width \bar{C}	1,3	mm
Plate tooth width B_1	7,2	mm
Plate tooth width b_1	7	mm
Plate tooth width B_2	21	mm
Plate tooth width B_3	34,9	mm

CHAIN

Pitch	12,7	mm
Inner width	7,75	mm
Roller \varnothing	8,51	mm

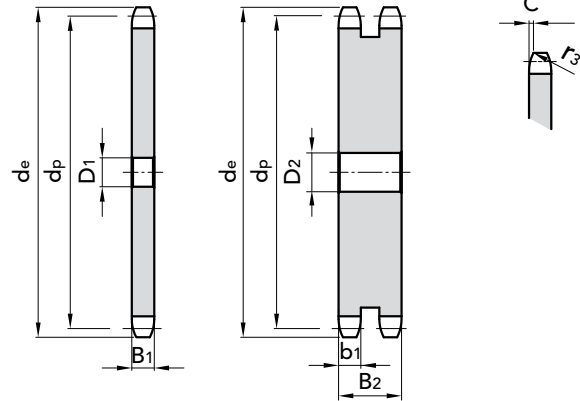

SIMPLEX						DUPLEX																		
Z	D ₁	d _e	d _p	P. NUMBER	kg.	Z	D ₁	d _e	d _p	P. NUMBER	kg.	Z	D ₁	d _e	d _p	P. NUMBER	kg.							
8	8	37,68	33,19	20112008	0,03	44	20	182,51	178,02	20112044	1,32	8	10	37,68	33,18	20212008	0,07	44	20	182,50	178,03	20212044	3,71	
9	8	41,62	37,13	20112009	0,04	45	20	186,50	182,06	20112045	1,38	9	10	41,62	37,13	20212009	0,10	45	20	186,50	182,07	20212045	3,89	
10	8	45,59	41,10	20112010	0,06	46	20	190,59	186,10	20112046	1,45	10	10	45,59	41,10	20212010	0,13	46	20	190,59	186,10	20212046	4,07	
11	10	49,57	45,08	20112011	0,07	47	20	194,63	190,14	20112047	1,51	11	12	49,57	45,07	20212011	0,17	47	20	194,63	190,14	20212047	4,36	
12	10	53,56	49,07	20112012	0,08	48	20	198,67	194,18	20112048	1,58	12	12	53,56	49,07	20212012	0,21	48	20	198,67	194,18	20212048	4,96	
13	10	57,56	53,07	20112013	0,10	49	20	202,71	198,22	20112049	1,65	13	12	57,56	53,06	20212013	0,25	49	20	202,71	198,22	20212049	4,66	
14	10	61,56	57,07	20112014	0,12	50	20	206,75	202,26	20112050	1,72	14	12	61,56	57,07	20212014	0,30	50	20	206,75	202,26	20212050	4,86	
15	10	65,57	61,08	20112015	0,14	51	20	210,79	206,30	20112051	1,80	15	12	65,57	61,09	20212015	0,36	51	25	210,79	206,30	20212051	5,03	
16	10	69,59	65,10	20112016	0,16	52	20	214,83	210,34	20112052	1,87	16	14	69,59	65,10	20212016	0,41	52	25	214,83	210,34	20212052	5,24	
17	10	73,61	69,12	20112017	0,18	53	20	218,87	214,38	20112053	1,94	17	14	73,61	69,11	20212017	0,47	53	25	218,87	214,37	20212053	5,46	
18	10	77,63	73,14	20112018	0,20	54	20	222,91	218,42	20112054	2,02	18	14	77,63	73,14	20212018	0,54	54	25	222,91	218,43	20212054	5,68	
19	10	81,65	77,16	20112019	0,23	55	20	226,95	222,46	20112055	2,10	19	14	81,65	77,16	20212019	0,61	55	25	226,95	222,46	20212055	5,90	
20	10	85,67	81,18	20112020	0,26	56	20	230,99	226,50	20112056	2,17	20	14	85,67	81,19	20212020	0,68	56	25	230,99	226,50	20212056	6,13	
21	12	89,70	85,21	20112021	0,28	57	20	235,03	230,54	20112057	2,25	21	16	89,70	85,22	20212021	0,75	57	25	235,03	230,54	20212057	6,36	
22	12	93,73	89,24	20112022	0,31	58	20	239,07	234,58	20112058	2,34	22	16	93,73	89,24	20212022	0,83	58	25	239,07	234,58	20212058	6,59	
23	12	97,76	93,27	20112023	0,34	60	20	247,15	242,66	20112060	2,50	23	16	97,76	93,27	20212023	0,92	60	25	247,15	242,66	20212060	7,08	
24	12	101,79	97,30	20112024	0,38	62	25	255,23	250,74	20112062	2,67	24	16	101,79	97,29	20212024	1,01	62	25	255,23	250,75	20212062	7,60	
25	12	105,8	101,33	20112025	0,41	64	25	263,32	258,83	20112064	2,85	25	16	105,80	101,33	20212025	1,10	64	25	263,32	258,82	20212064	8,10	
26	16	109,85	105,36	20112026	0,44	65	25	267,36	262,87	20112065	2,94	26	16	109,85	105,36	20212026	1,20	65	25	267,36	262,86	20212065	8,36	
27	16	113,89	109,40	20112027	0,48	66	25	271,40	266,91	20112066	3,03	27	16	113,89	109,40	20212027	1,31	66						
28	16	117,92	113,42	20112028	0,52	68	25	279,48	274,99	20112068	3,22	28	16	117,92	113,42	20212028	1,42	68	25	279,48	274,99	20212068	9,17	
29	16	121,95	117,46	20112029	0,56	70	25	287,56	283,07	20112070	3,42	29	16	121,95	117,46	20212029	1,53	70	25	287,56	283,07	20212070	9,75	
30	16	125,99	121,50	20112030	0,60	72	25	295,64	291,15	20112072	3,62	30	16	125,99	121,50	20212030	1,65	72	25	295,64	291,16	20212072	10,00	
31	16	130,02	125,53	20112031	0,64	75	25	307,77	303,28	20112075	3,94	31	16	130,02	125,54	20212031	1,77	75	25	307,77	303,27	20212075	11,24	
32	16	134,06	129,57	20112032	0,68	76	25	311,81	307,32	20112076	4,05	32	16	134,06	129,56	20212032	1,90	76	25	311,81	307,33	20212076	11,35	
33	16	138,10	133,61	20112033	0,73	78	25	319,89	315,40	20112078	4,27	33	16	138,10	133,60	20212033	2,02	78						
34	16	142,13	137,64	20112034	0,78	80	25	327,98	323,49	20112080	4,50	34	16	142,13	137,64	20212034	2,16	80	25	327,98	323,48	20212080	12,05	
35	16	146,17	141,68	20112035	0,83	85	25	348,18	343,69	20112085	5,62	35	16	146,17	141,68	20212035	2,30	85	25	348,18	343,70	20212085	14,01	
36	16	150,21	145,72	20112036	0,88	90	25	368,39	363,90	20112090	6,31	36	20	150,21	145,72	20212036	2,42	90	25	368,39	363,90	20212090	15,85	
37	16	154,24	149,75	20112037	0,93	95	25	388,60	384,11	20112095	7,05	37	20	154,24	149,76	20212037	2,56	95	25	388,60	384,11	20212095	18,00	
38	16	158,28	153,79	20112038	0,98	100	25	408,81	404,32	20112100	7,82	38	20	158,28	153,80	20212038	2,71	100	25	408,81	404,32	20212100	20,30	
39	16	162,32	157,83	20112039	1,03	110	25	449,23	444,74	20112110	9,50	39	20	162,32	157,83	20212039	2,87	110	25	449,23	444,74	20212110	24,66	
40	16	166,36	161,87	20112040	1,09	114	25	465,40	460,91	20112114	10,21	40	20	166,36	161,87	20212040	3,03	114	25	465,40	460,90	20212114	26,00	
41	20	170,40	165,91	20112041	1,14	120	25	489,65	485,16	20112120	11,32	41	20	170,40	165,91	20212041	3,20	120	25	489,65	485,16	20212120	29,45	
42	20	174,43	169,94	20112042	1,20	125	25	509,86	505,37	20112125	12,31	42	20	174,43	169,95	20212042	3,36	125	25	509,86	505,37	20212125	32,00	
43	20	178,47	173,98	20112043	1,26							43	20	178,47	173,99	20212043	3,53							

MATERIAL **FE / C45**

Ask for specific needs.

CAD drawings available on our site
www.chiaravalli.com

Quantity, availability and prices
on B2B Chiaravalli





1/2" x 5/16"

PLATEWHEEL

Tooth radius r_3	13	mm
Radius width C	1,3	mm
Plate tooth width B_1	7,2	mm
Plate tooth width b_1	7	mm
Plate tooth width B_2	21	mm
Plate tooth width B_3	34,9	mm

CHAIN

Pitch	12,7	mm
Inner width	7,75	mm
Roller \varnothing	8,51	mm

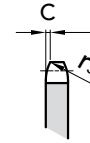
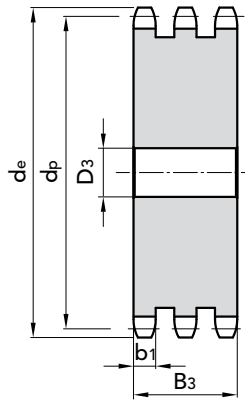

PLATEWHEELS 1/2" x 5/16"
for roller chains in compliance
with DIN 8187 - ISO/R 606

TRIPLEX

Z	D ₁	d _e	d _p	P. NUMBER	kg.	Z	D ₁	d _e	d _p	P. NUMBER	kg.
8	10	37,68	33,18	20312008	0,11	44	25	182,51	178,03	20312044	6,09
9	12	41,62	37,13	20312009	0,16	45	25	186,50	182,07	20312045	6,39
10	12	45,59	41,10	20312010	0,21	46	25	190,59	186,10	20312046	6,70
11	14	49,57	45,07	20312011	0,26	47	25	194,63	190,14	20312047	7,00
12	14	53,56	49,07	20312012	0,33	48	25	198,67	194,18	20312048	7,33
13	14	57,56	53,06	20312013	0,40	49	25	202,71	198,22	20312049	7,84
14	14	61,56	57,07	20312014	0,48	50	25	206,75	202,26	20312050	8,00
15	14	65,57	61,09	20312015	0,57	51					
16	16	69,59	65,10	20312016	0,64	52	25	214,83	210,34	20312052	8,68
17	16	73,61	69,11	20312017	0,74	53	25	218,87	214,37	20312053	9,02
18	16	77,63	73,14	20312018	0,85	54	25	222,91	218,43	20312054	9,40
19	16	81,65	77,16	20312019	0,97	55	25	226,95	222,46	20312055	9,77
20	16	85,67	81,19	20312020	1,09	56	25	230,99	226,50	20312056	10,15
21	20	89,70	85,22	20312021	1,22	57	25	235,03	230,54	20312057	10,53
22	20	93,73	89,24	20312022	1,36	58					
23	20	97,76	93,27	20312023	1,50	60	25	247,15	242,66	20312060	11,73
24	20	101,79	97,29	20312024	1,63	62	25	255,23	250,75	20312062	13,86
25	20	105,80	101,33	20312025	1,81	64	25	263,32	258,82	20312064	15,22
26	20	109,85	105,36	20312026	1,98	65	25	267,36	262,86	20312065	15,56
27	20	113,89	109,40	20312027	2,15	66					
28	20	117,92	113,42	20312028	2,33	68	25	279,48	274,99	20312068	15,72
29	20	121,95	117,46	20312029	2,52	70	25	295,64	283,07	20312070	16,17
30	20	125,99	121,50	20312030	2,71	72	25	295,64	291,16	20312072	17,14
31	20	130,02	125,54	20312031	2,94	75	25	307,77	303,27	20312075	18,65
32	20	134,06	129,56	20312032	3,09	76	25	311,81	307,33	20312076	19,17
33	20	138,10	133,60	20312033	3,30	78					
34	20	142,13	137,64	20312034	3,53	80	25	327,98	323,48	20312080	21,82
35	20	146,17	141,68	20312035	3,76	85	25	348,18	343,70	20312085	24,15
36	25	150,21	145,72	20312036	3,99	90	25	368,39	363,90	20312090	27,17
37						95	25	388,60	384,11	20312095	30,36
38	25	158,28	153,80	20312038	4,49	100	25	408,81	404,32	20312100	33,73
39						110					
40	25	166,36	161,87	20312040	5,00	114	25	465,40	460,90	20312114	44,10
41						120	25	489,65	485,16	20312120	49,70
42	25	174,43	169,95	20312042	5,51	125	25	509,86	505,37	20312125	55,21
43	25	178,47	173,99	20312043	5,80						

MATERIAL **FE / C45**

Ask for specific needs.

CAD drawings available on our site
www.chiaravalli.com

Quantity, availability and prices
on B2B Chiaravalli





PLATEWHEELS 5/8" x 3/8"
for roller chains in compliance
with DIN 8187 - ISO/R 606

5/8" x 3/8"

PLATEWHEEL

Tooth radius r_3	16	mm
Radius width \bar{C}	1,6	mm
Plate tooth width B_1	9,1	mm
Plate tooth width b_1	9	mm
Plate tooth width B_2	25,5	mm
Plate tooth width B_3	42,1	mm

CHAIN

Pitch	15,875	mm
Inner width	9,65	mm
Roller \varnothing	10,16	mm

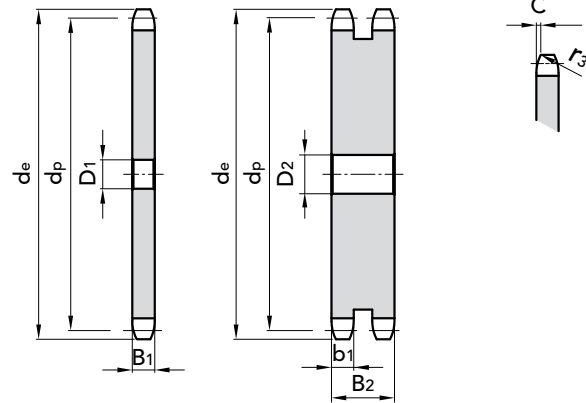

SIMPLEX

DUPLEX

Z	D ₁	d _e	d _p	P. NUMBER	kg.	Z	D ₁	d _e	d _p	P. NUMBER	kg.	Z	D ₁	d _e	d _p	P. NUMBER	kg.	Z	D ₁	d _e	d _p	P. NUMBER	kg.
8	10	48,32	41,48	20115008	0,06	44	20	229,37	222,53	20115044	2,63	8	12	48,32	41,48	20215008	0,15	44	20	229,37	222,53	20215044	7,13
9	10	53,26	46,42	20115009	0,09	45	20	234,42	227,58	20115045	2,75	9	12	53,26	46,42	20215009	0,21	45	25	234,42	227,58	20215045	7,47
10	10	58,21	51,37	20115010	0,11	46	20	239,47	232,63	20115046	2,88	10	12	58,21	51,37	20215010	0,27	46	25	239,47	232,63	20215046	7,83
11	10	63,19	56,35	20115011	0,14	47	20	244,52	237,68	20115047	3,01	11	14	63,19	56,34	20215011	0,34	47	25	244,52	237,68	20215047	8,19
12	10	68,18	61,34	20115012	0,17	48	20	249,57	242,73	20115048	3,14	12	14	68,18	61,34	20215012	0,42	48	25	249,57	242,73	20215048	8,55
13	10	73,17	66,33	20115013	0,20	49	20	254,62	247,78	20115049	3,28	13	14	73,17	66,32	20215013	0,51	49	25	254,62	247,78	20215049	8,94
14	10	78,18	71,34	20115014	0,23	50	20	259,66	252,82	20115050	3,42	14	14	78,18	71,34	20215014	0,60	50	25	259,66	252,82	20215050	9,32
15	10	83,19	76,35	20115015	0,27	51	20	264,71	257,87	20115051	3,56	15	14	83,19	76,36	20215015	0,70	51	25	264,71	257,87	20215051	9,85
16	12	88,21	81,37	20115016	0,31	52	20	269,76	262,92	20115052	3,70	16	16	88,21	81,37	20215016	0,82	52	25	269,76	262,92	20215052	10,11
17	12	93,23	86,39	20115017	0,36	53	20	274,81	267,97	20115053	3,85	17	16	93,23	86,38	20215017	0,94	53	25	274,81	267,97	20215053	10,52
18	12	98,26	91,42	20115018	0,41	54	20	279,87	273,03	20115054	4,00	18	16	98,26	91,42	20215018	1,06	54	25	279,87	273,03	20215054	10,94
19	12	103,29	96,45	20115019	0,46	55	20	284,92	278,08	20115055	4,15	19	16	103,29	96,45	20215019	1,20	55	25	284,92	278,08	20215055	11,36
20	12	108,32	101,48	20115020	0,51	56	25	289,97	283,13	20115056	4,30	20	16	108,32	101,49	20215020	1,34	56	25	289,97	283,13	20215056	11,80
21	12	113,35	106,51	20115021	0,57	57	25	295,02	288,18	20115057	4,46	21	16	113,35	106,52	20215021	1,48	57	25	295,02	288,18	20215057	12,24
22	12	118,39	111,55	20115022	0,62	58	25	300,07	293,23	20115058	4,62	22	16	118,39	111,55	20215022	1,64	58	25	300,07	293,23	20215058	12,68
23	12	123,43	116,59	20115023	0,69	60	25	310,17	303,33	20115060	4,95	23	16	123,43	116,58	20215023	1,80	60	25	310,17	303,32	20215060	13,61
24	12	128,46	121,62	20115024	0,75	62	25	320,27	313,43	20115062	5,30	24	16	128,46	121,62	20215024	1,98	62	25	320,27	313,43	20215062	14,56
25	12	133,50	126,66	20115025	0,82	64	25	330,37	323,53	20115064	5,65	25	16	133,50	126,66	20215025	2,17	64					
26	16	138,54	131,70	20115026	0,88	65	25	335,42	328,58	20115065	5,83	26	16	138,54	131,70	20215026	2,33	65	25	335,42	328,58	20215065	16,05
27	16	143,58	136,74	20115027	0,95	68	25	350,58	343,74	20115068	6,40	27	16	143,58	136,75	20215027	2,53	68					
28	16	148,63	141,79	20115028	1,03	70	25	360,68	353,84	20115070	6,79	28	16	148,63	141,78	20215028	2,74	70	25	360,68	353,84	20215070	16,57
29	16	153,67	146,83	20115029	1,11	72	25	370,78	363,94	20115072	7,19	29	16	153,67	146,83	20215029	2,96	72	25	370,78	363,95	20215072	18,70
30	16	158,71	151,87	20115030	1,19	75	25	385,94	379,10	20115075	7,81	30	16	158,71	151,87	20215030	3,18	75	25	385,94	379,09	20215075	19,81
31	16	163,76	156,92	20115031	1,28	76	25	390,99	384,15	20115076	8,02	31	20	163,76	156,92	20215031	3,41	76	25	390,99	384,16	20215076	21,54
32	16	168,80	161,96	20115032	1,36	78	25	401,09	394,25	20115078	8,46	32	20	168,80	161,95	20215032	3,66	78	25	401,09	394,25	20215078	22,14
33	16	174,85	167,01	20115033	1,45	80	25	411,20	404,36	20115080	8,91	33	20	174,85	167,00	20215033	3,90	80	25	411,20	404,35	20215080	21,60
34	16	178,89	172,05	20115034	1,55	85	30	436,46	429,62	20115085	10,06	34	20	178,89	172,05	20215034	4,16	85	30	436,46	429,62	20215085	28,00
35	16	183,94	177,10	20115035	1,64	90	30	461,72	454,88	20115090	11,30	35	20	183,94	177,10	20215035	4,42	90	30	461,72	454,88	20215090	31,25
36	20	188,99	182,15	20115036	1,73	95	30	486,98	480,14	20115095	12,61	36	20	188,99	182,15	20215036	4,70	95	30	486,98	480,14	20215095	34,90
37	20	194,03	187,19	20115037	1,83	100	30	512,24	505,40	20115100	13,99	37	20	194,03	187,20	20215037	4,98	100	30	512,24	505,39	20215100	38,75
38	20	199,08	192,24	20115038	1,94	110	30	562,76	555,92	20115110	17,00	38	20	199,08	192,24	20215038	5,26	110	30	562,76	555,92	20215110	46,85
39	20	204,13	197,29	20115039	2,05	114	30	582,97	576,13	20115114	19,99	39	20	204,13	197,29	20215039	5,56	114	30	582,97	576,13	20215114	50,60
40	20	209,17	202,33	20115040	2,16	120	30	613,29	606,45	20115120	22,17	40	20	209,17	202,34	20215040	5,87	120	30	613,29	606,45	20215120	56,16
41	20	214,22	207,38	20115041	2,29	125	30	638,55	631,71	20115125	24,08	41	20	214,22	207,39	20215041	5,10	125	30	638,55	631,51	20215125	61,00
42	20	219,27	212,43	20115042	2,39							42	20	219,27	212,44	20215042	6,46						
43	20	224,32	217,48	20115043	2,50							43	20	224,32	217,49	20215043	6,80						

MATERIAL **FE / C45**
Ask for specific needs.

CAD drawings available on our site
www.chiaravalli.com

Quantity, availability and prices
on B2B Chiaravalli





5/8" x 3/8"

PLATEWHEEL

Tooth radius r_3	16	mm
Radius width C	1,6	mm
Plate tooth width B_1	9,1	mm
Plate tooth width b_1	9	mm
Plate tooth width B_2	25,5	mm
Plate tooth width B_3	42,1	mm

CHAIN

Pitch	15,875	mm
Inner width	9,65	mm
Roller \varnothing	10,16	mm

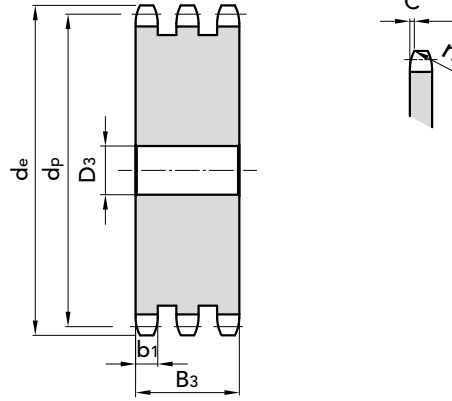

PLATEWHEELS 5/8" x 3/8"
for roller chains in compliance
with DIN 8187 - ISO/R 606

TRIPLEX

Z	D ₁	d _e	d _p	P. NUMBER	kg.	Z	D ₁	d _e	d _p	P. NUMBER	kg.
8	12	48,32	41,48	20315008	0,23	44	25	229,37	222,53	20315044	11,67
9	12	53,26	46,42	20315009	0,32	45	25	234,42	227,58	20315045	12,24
10	16	58,21	51,37	20315010	0,44	46	25	239,47	232,63	20315046	12,82
11	16	63,19	56,34	20315011	0,55	47	25	244,52	237,68	20315047	13,10
12	16	68,18	61,34	20315012	0,67	48	25	249,57	242,73	20315048	14,01
13	16	73,17	66,32	20315013	0,81	49	25	254,62	247,78	20315049	14,86
14	16	78,18	71,34	20315014	0,97	50	25	259,66	252,82	20315050	15,26
15	16	83,19	76,36	20315015	1,14	51					
16	16	88,21	81,37	20315016	1,29	52	25	269,76	262,92	20315052	16,57
17	16	93,23	86,38	20315017	1,49	53	25	274,81	267,97	20315053	17,20
18	16	98,26	91,42	20315018	1,70	54					
19	16	103,29	96,45	20315019	1,92	55	25	284,92	278,08	20315055	18,62
20	16	108,32	101,49	20315020	2,15	56					
21	20	113,35	106,52	20315021	2,40	57	25	295,02	288,18	20315057	20,06
22	20	118,89	111,55	20315022	2,66	58					
23	20	123,43	116,58	20315023	2,94	60	25	310,17	303,32	20315060	22,31
24	20	128,46	121,62	20315024	3,23	62					
25	20	133,50	126,66	20315025	3,53	64	30	330,37	323,53	20315064	25,43
26	20	138,54	131,70	20315026	3,81	65	30	335,42	328,58	20315065	26,26
27	20	143,58	136,75	20315027	4,13	68	30	350,58	343,74	20315068	28,59
28	20	148,63	141,78	20315028	4,47	70	30	360,68	353,84	20315070	30,61
29	20	153,67	146,83	20315029	4,83	72	30	370,78	363,95	20315072	30,54
30	20	158,71	151,87	20315030	5,20	75	30	385,94	379,09	20315075	30,35
31	20	163,76	156,92	20315031	5,42	76	30	390,99	384,16	20315076	36,27
32	20	168,80	161,95	20315032	5,97	78					
33	20	174,85	167,00	20315033	6,38	80	30	411,20	404,35	20315080	40,30
34	20	179,89	172,05	20315034	6,80	85	30	436,46	429,62	20315085	45,60
35	20	183,94	177,10	20315035	7,23	90	30	461,72	454,88	20315090	51,32
36	25	188,99	182,15	20315036	7,62	95	30	486,98	480,14	20315095	57,32
37	25	194,03	187,20	20315037	8,08	100	30	512,24	505,39	20315100	63,60
38	25	199,08	192,24	20315038	8,55	110	30	562,76	555,92	20315110	77,27
39	25	204,13	197,29	20315039	9,04	114	30	582,97	576,13	20315114	83,15
40	25	209,17	202,34	20315040	9,54	120					
41	25	214,22	207,39	20315041	10,05	125	30	638,55	631,51	20315125	99,50
42	25	219,27	212,44	20315042	10,58						
43	25	224,32	217,49	20315043	10,98						

MATERIAL **FE / C45**

Ask for specific needs.

CAD drawings available on our site
www.chiaravalli.com

Quantity, availability and prices
on B2B Chiaravalli





PLATEWHEELS 3/4" x 7/16"
for roller chains in compliance
with DIN 8187 - ISO/R 606

3/4" x 7/16"

PLATEWHEEL

Tooth radius r_3	19	mm
Radius width \bar{C}	2	mm
Plate tooth width B_1	11,1	mm
Plate tooth width b_1	10,8	mm
Plate tooth width B_2	30,3	mm
Plate tooth width B_3	49,8	mm

CHAIN

Pitch	19,05	mm
Inner width	11,68	mm
Roller \varnothing	12,07	mm

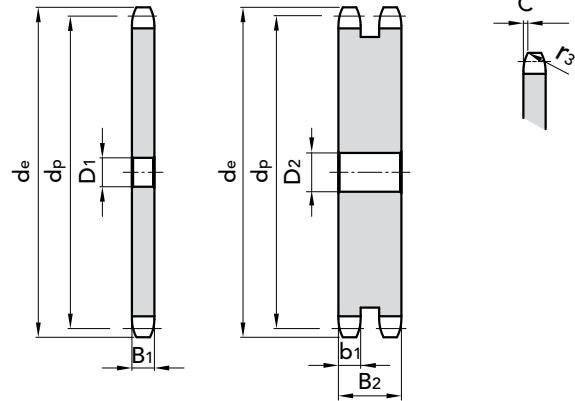

SIMPLEX

Z	D ₁	d _e	d _p	P. NUMBER	kg.
8	12	57,31	49,78	20119008	0,12
9	12	63,23	55,70	20119009	0,15
10	12	69,18	61,65	20119010	0,20
11	14	75,15	67,62	20119011	0,24
12	14	81,13	73,60	20119012	0,30
13	14	87,13	79,60	20119013	0,35
14	14	93,14	85,61	20119014	0,41
15	14	99,16	91,63	20119015	0,48
16	14	105,18	97,65	20119016	0,55
17	14	111,20	103,67	20119017	0,63
18	14	117,23	109,70	20119018	0,71
19	14	123,27	115,74	20119019	0,80
20	14	129,31	121,78	20119020	0,89
21	16	135,35	127,82	20119021	0,99
22	16	141,39	133,86	20119022	1,03
23	16	147,43	139,90	20119023	1,20
24	16	153,48	145,95	20119024	1,31
25	16	159,52	151,99	20119025	1,43
26	16	165,57	158,04	20119026	1,56
27	16	171,62	164,09	20119027	1,68
28	16	177,67	170,14	20119028	1,82
29	16	183,72	176,19	20119029	1,96
30	16	189,78	182,25	20119030	2,10
31	20	195,83	188,30	20119031	2,24
32	20	201,88	194,35	20119032	2,39
33	20	207,94	200,41	20119033	2,55
34	20	213,99	206,46	20119034	2,71
35	20	220,05	212,52	20119035	2,88
36	20	226,10	218,57	20119036	3,06
37	20	232,16	224,63	20119037	3,24
38	20	238,22	230,69	20119038	3,42
39	20	244,27	236,74	20119039	3,61
40	20	250,33	242,80	20119040	3,80
41	25	256,39	248,86	20119041	3,98
42	25	262,45	254,92	20119042	4,19
43	25	268,51	260,98	20119043	4,38

DUPLEX

Z	D ₁	d _e	d _p	P. NUMBER	kg.
8	12	57,31	49,78	20219008	0,26
9	12	62,23	55,70	20219009	0,36
10	12	69,18	61,65	20219010	0,46
11	16	75,15	67,62	20219011	0,59
12	16	81,13	73,60	20219012	0,72
13	16	87,13	79,60	20219013	0,88
14	16	93,14	85,61	20219014	1,02
15	16	99,16	91,63	20219015	1,20
16	20	105,18	97,65	20219016	1,39
17	20	111,20	103,67	20219017	1,60
18	20	117,23	109,70	20219018	1,81
19	20	123,27	115,74	20219019	2,05
20	20	129,31	121,78	20219020	2,30
21	20	135,35	127,82	20219021	2,53
22	20	141,39	133,86	20219022	2,80
23	20	147,43	139,90	20219023	3,09
24	20	153,48	145,95	20219024	3,39
25	20	159,52	151,99	20219025	3,70
26	20	165,57	158,04	20219026	4,03
27	20	171,62	164,09	20219027	4,38
28	20	177,67	170,14	20219028	4,73
29	20	183,72	176,19	20219029	5,10
30	20	189,78	182,25	20219030	5,49
31	20	195,83	188,30	20219031	5,88
32	20	201,88	194,35	20219032	6,30
33	20	207,94	200,41	20219033	6,72
34	20	213,99	206,46	20219034	7,16
35	20	220,05	212,52	20219035	7,61
36	25	226,10	218,57	20219036	7,99
37	25	232,16	224,63	20219037	8,47
38	25	238,22	230,69	20219038	8,96
39	25	244,27	236,74	20219039	9,50
40	25	250,33	242,80	20219040	9,99
41	25	256,39	248,86	20219041	10,51
42	25	262,45	254,92	20219042	11,07
43	25	268,51	260,98	20219043	11,63

MATERIAL **FE / C45**

Ask for specific needs.

CAD drawings available on our site
www.chiaravalli.com

Quantity, availability and prices
on B2B Chiaravalli





3/4" x 7/16"

PLATEWHEEL

Tooth radius r_3	19	mm
Radius width C	2	mm
Plate tooth width B_1	11,1	mm
Plate tooth width b_1	10,8	mm
Plate tooth width B_2	30,3	mm
Plate tooth width B_3	49,8	mm

CHAIN

Pitch	19,05	mm
Inner width	11,68	mm
Roller \varnothing	12,07	mm

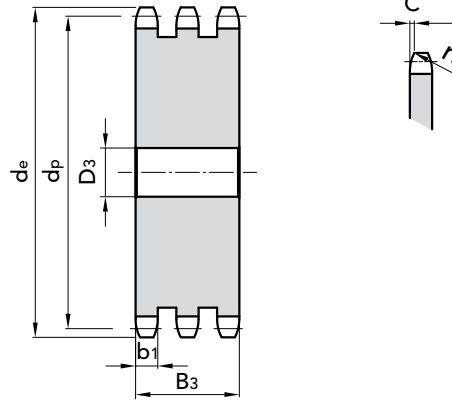

PLATEWHEELS 3/4" x 7/16"
for roller chains in compliance
with DIN 8187 - ISO/R 606

TRIPLEX

Z	D ₁	d _e	d _p	P. NUMBER	kg.	Z	D ₁	d _e	d _p	P. NUMBER	kg.
8	16	57,31	49,78	20319008	0,31	44	25	274,56	267,03	20319044	20,03
9	16	63,23	55,70	20319009	0,57	45	25	280,62	273,09	20319045	21,00
10	16	69,18	61,65	20319010	0,74	46					
11	20	75,15	67,62	20319011	0,91	47	25	294,74	285,21	20319047	23,00
12	20	81,13	73,60	20319012	1,13	48	25	298,80	291,27	20319048	24,04
13	20	87,13	79,60	20319013	1,38	49					
14	20	93,14	85,61	20319014	1,64	50	25	310,92	303,39	20319050	26,17
15	20	99,16	91,63	20319015	1,93	51					
16	20	105,18	97,65	20319016	2,20	52	25	323,04	315,51	20319052	28,40
17	20	111,20	103,67	20319017	2,54	53					
18	20	117,23	109,70	20319018	2,89	54	25	335,16	327,63	20319054	30,72
19	20	123,27	115,74	20319019	3,27	55	25	341,22	333,69	20319055	31,91
20	20	129,31	121,78	20319020	3,67	56					
21	20	135,35	127,82	20319021	4,10	57	30	353,34	345,81	20319057	34,00
22	20	141,39	133,86	20319022	4,55	58	30	359,40	351,87	20319058	34,28
23	20	147,43	139,90	20319023	5,02	59					
24	20	153,48	145,95	20319024	5,51	60	30	371,52	363,99	20319060	38,00
25	20	159,52	151,99	20319025	6,02	62					
26	20	165,57	158,04	20319026	6,56	64					
27	20	171,62	164,09	20319027	7,12	65	30	401,83	394,30	20319065	45,00
28	20	177,67	170,14	20319028	7,71	68					
29	20	183,72	176,19	20319029	8,31	70	30	432,14	424,61	20319070	52,42
30	20	189,78	182,25	20319030	8,97	72	30	444,26	436,73	20319072	55,55
31	25	195,83	188,30	20319031	9,52	75					
32	25	201,88	194,35	20319032	10,19	76	30	468,51	460,98	20319076	62,09
33	25	207,94	200,41	20319033	10,89	78					
34	25	213,99	206,46	20319034	11,61	80	30	492,76	485,23	20319080	68,98
35	25	220,05	212,52	20319035	12,35	85	30	510,95	503,42	20319085	78,10
36	25	226,10	218,57	20319036	13,11	90	30	553,38	545,85	20319090	87,79
37	25	232,16	224,63	20319037	13,90	95	30	583,70	576,17	20319095	98,04
38	25	238,22	230,69	20319038	14,70	100	30	614,01	606,48	20319100	108,86
39	25	244,27	236,74	20319039	17,54	110	30	674,64	667,11	20319110	120,30
40	25	250,33	242,80	20319040	16,40	114	30	698,89	691,36	20319114	142,15
41						120	30	735,27	727,74	20319120	157,77
42	25	262,45	254,92	20319042	18,17	125	30	765,59	758,06	20319125	171,41
43	25	268,51	260,98	20319043	19,09						

MATERIAL **FE / C45**
Ask for specific needs.

CAD drawings available on our site
www.chiaravalli.com

Quantity, availability and prices
on B2B Chiaravalli





PLATEWHEELS 1" x 17.02 mm
for roller chains in compliance
with DIN 8187 - ISO/R 606

1" x 17.02 mm

PLATEWHEEL

Tooth radius r_3	26	mm
Radius width \check{C}	2,5	mm
Plate tooth width B_1	16,2	mm
Plate tooth width b_1	15,8	mm
Plate tooth width B_2	47,7	mm
Plate tooth width B_3	79,6	mm

CHAIN

Pitch	25,4	mm
Inner width	17,02	mm
Roller \varnothing	15,88	mm

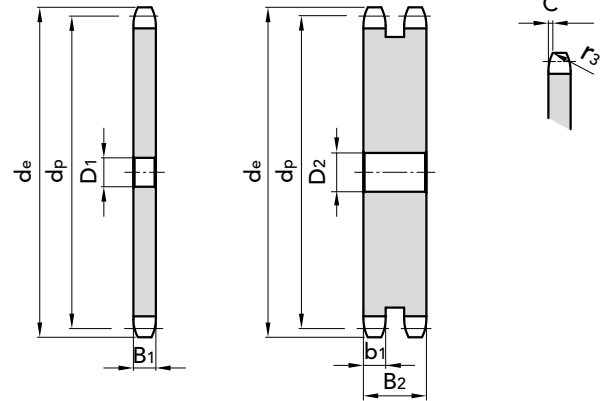

SIMPLEX

Z	D ₁	d _e	d _p	P. NUMBER	kg.
8	14	77,49	66,37	20125008	0,30
9	14	85,38	74,26	20125009	0,39
10	15	93,32	82,20	20125010	0,51
11	15	101,28	90,14	20125011	0,63
12	15	109,26	98,14	20125012	0,77
13	15	117,26	106,14	20125013	0,92
14	15	125,27	114,15	20125014	1,08
15	15	133,29	122,17	20125015	1,26
16	19	141,32	130,20	20125016	1,43
17	19	149,35	138,23	20125017	1,64
18	19	157,39	146,27	20125018	1,85
19	19	165,44	154,32	20125019	2,08
20	19	173,49	162,37	20125020	2,32
21	20	181,54	170,42	20125021	2,58
22	20	189,60	178,48	20125022	2,84
23	20	197,66	186,54	20125023	3,13
24	20	205,72	194,60	20125024	3,42
25	20	213,78	202,66	20125025	3,73
26	20	221,80	210,72	20125026	4,05
27	20	229,91	218,79	20125027	4,38
28	20	237,98	226,86	20125028	4,73
29	20	246,05	234,93	20125029	5,09
30	20	254,12	243,00	20125030	5,46
31	25	262,19	251,07	20125031	5,82
32	25	270,26	259,14	20125032	6,22
33	25	278,33	267,21	20125033	6,63
34	25	287,40	275,28	20125034	7,06
35	25	294,48	283,36	20125035	7,50
36	25	302,55	291,43	20125036	7,95
37	25	310,63	299,51	20125037	8,41
38	25	318,70	307,58	20125038	8,88
39	25	326,78	315,66	20125039	9,37
40	25	334,86	323,74	20125040	9,88
41	25	342,93	331,81	20125041	10,39
42	25	351,01	339,89	20125042	10,92
43	25	359,09	347,97	20125043	11,46

DUPLEX

Z	D ₁	d _e	d _p	P. NUMBER	kg.
8	16	77,49	66,37	20225008	0,71
9	16	85,38	74,26	20225009	0,97
10	16	93,32	82,20	20225010	1,27
11	20	101,28	90,14	20225011	1,57
12	20	109,26	98,14	20225012	1,94
13	20	117,26	106,14	20225013	2,36
14	20	125,27	114,15	20225014	2,81
15	20	133,29	122,17	20225015	3,31
16	20	141,32	130,20	20225016	3,84
17	20	149,35	138,23	20225017	4,41
18	20	157,39	146,27	20225018	5,01
19	20	165,44	154,32	20225019	5,66
20	20	173,49	162,37	20225020	6,34
21	25	181,54	170,42	20225021	7,00
22	25	189,60	178,48	20225022	7,76
23	25	197,66	186,54	20225023	8,56
24	25	205,72	194,60	20225024	9,40
25	25	213,78	202,66	20225025	10,28
26	25	221,80	210,72	20225026	11,20
27	25	229,91	218,79	20225027	12,15
28	25	237,98	226,86	20225028	13,14
29	25	246,05	234,93	20225029	14,17
30	25	254,12	243,00	20225030	15,24
31	25	262,19	251,07	20225031	16,35
32	25	270,26	259,14	20225032	17,50
33	25	278,33	267,21	20225033	18,68
34	25	287,40	275,28	20225034	19,90
35	25	294,48	283,36	20225035	21,16
36	25	302,55	291,43	20225036	22,46
37	25	310,63	299,51	20225037	23,80
38	25	318,70	307,58	20225038	25,18
39	25	326,78	315,66	20225039	26,59
40	25	334,86	323,74	20225040	28,04
41					
42	25	351,01	339,89	20225042	31,07
43	25	359,09	347,97	20225043	32,65

MATERIAL **FE / C45**

Ask for specific needs.

CAD drawings available on our site
www.chiaravalli.com

Quantity, availability and prices
on B2B Chiaravalli





1" x 17.02 mm

PLATEWHEEL

Tooth radius r_3	26	mm
Radius width C	2,5	mm
Plate tooth width B_1	16,2	mm
Plate tooth width b_1	15,8	mm
Plate tooth width B_2	47,7	mm
Plate tooth width B_3	79,6	mm

CHAIN

Pitch	25,4	mm
Inner width	17,02	mm
Roller \varnothing	15,88	mm

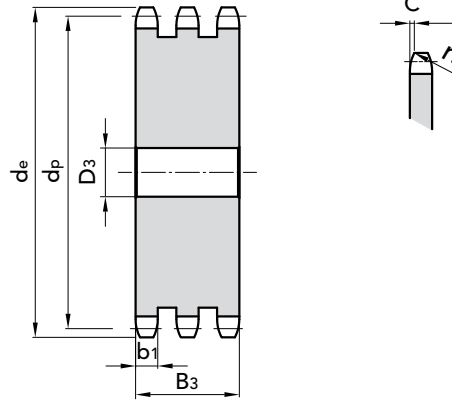

PLATEWHEELS 1" x 17.02 mm
for roller chains in compliance
with DIN 8187 - ISO/R 606

TRIPLEX

Z	D ₁	d _e	d _p	P. NUMBER	kg.	Z	D ₁	d _e	d _p	P. NUMBER	kg.
8	20	77,49	66,37	20325008	1,13	44	30	367,17	356,05	20325044	56,63
9	20	85,38	74,26	20325009	1,56	45	30	375,24	364,12	20325045	59,36
10	20	93,32	82,20	20325010	2,05	46	30	383,32	372,20	20325046	62,17
11	25	101,28	90,14	20325011	2,53	47					
12	25	109,26	98,14	20325012	3,15	48	30	399,48	388,36	20325048	67,97
13	25	117,26	106,14	20325013	3,84	49					
14	25	125,27	114,15	20325014	4,59	50	30	415,64	404,52	20325050	74,01
15	25	133,29	122,17	20325015	5,40	51					
16	30	141,32	130,20	20325016	6,16	52	40	431,80	420,68	20325052	79,98
17	30	149,35	138,23	20325017	7,11	53					
18	30	157,39	146,27	20325018	8,11	54					
19	30	165,44	154,32	20325019	9,18	55	40	456,04	444,92	20325055	89,92
20	30	173,49	162,37	20325020	10,31	56					
21	30	181,54	170,42	20325021	11,51	57	40	472,20	461,08	20325057	96,87
22	30	189,60	178,48	20325022	12,77	58					
23	30	197,66	186,54	20325023	14,10	60	40	496,45	485,33	20325060	107,78
24	30	205,72	194,60	20325024	14,49	62					
25	30	213,78	202,66	20325025	16,94	64					
26	30	221,80	210,72	20325026	18,33	65	40	536,85	525,73	20325065	127,24
27	30	229,91	218,79	20325027	19,91	68	40	561,10	579,98	20325068	137,78
28	30	237,98	226,86	20325028	21,55	70	40	577,27	566,15	20325070	148,31
29	30	246,05	234,93	20325029	23,26	72	40	593,43	582,31	20325072	157,18
30	30	254,12	243,00	20325030	25,04	75					
31	30	262,19	251,07	20325031	26,88	76	40	625,76	614,64	20325076	175,70
32	30	270,26	259,14	20325032	28,78	78					
33	30	278,33	267,21	20325033	30,75	80	40	658,09	646,97	20325080	195,25
34	30	287,40	275,28	20325034	32,78	85	40	698,51	687,39	20325085	221,13
35	30	294,48	283,36	20325035	34,88	90	40	738,92	727,80	20325090	248,61
36	30	302,55	291,43	20325036	37,04	95	40	779,34	768,22	20325095	277,70
37						100					
38	30	318,70	307,58	20325038	41,56	110					
39						114	40	932,93	921,81	20325114	402,85
40	30	334,86	323,74	20325040	46,42	120					
41						125	40	1021,86	1010,74	20325125	485,90
42	30	351,01	339,89	20325042	51,34						
43											

MATERIAL **FE / C45**

Ask for specific needs.

CAD drawings available on our site
www.chiaravalli.com

Quantity, availability and prices
on B2B Chiaravalli





PLATEWHEELS 1" 1/4 x 3/4"
for roller chains in compliance
with DIN 8187 - ISO/R 606

1" 1/4 x 3/4"

PLATEWHEEL

Tooth radius r_3	32	mm
Radius width \bar{C}	3,5	mm
Plate tooth width B_1	18,5	mm
Plate tooth width b_1	18,2	mm
Plate tooth width B_2	54,6	mm
Plate tooth width B_3	91	mm

CHAIN

Pitch	31,75	mm
Inner width	19,56	mm
Roller \varnothing	19,05	mm

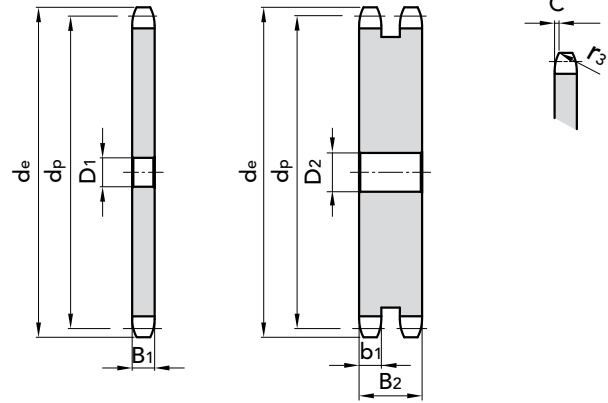

SIMPLEX

Z	D ₁	d _e	d _p	P. NUMBER	kg.
8	16	98,10	82,96	20131008	0,55
9	16	108,0	92,84	20131009	0,73
10	16	117,9	102,74	20131010	0,93
11	16	127,8	112,68	20131011	1,13
12	20	137,8	122,68	20131012	1,38
13	20	147,8	132,65	20131013	1,65
14	20	157,8	142,68	20131014	1,94
15	20	167,9	152,72	20131015	2,26
16	25	177,9	162,75	20131016	2,60
17	25	187,9	172,78	20131017	2,96
18	25	198,0	182,85	20131018	3,34
19	25	208,1	192,91	20131019	3,75
20	25	218,1	202,98	20131020	4,19
21	25	228,2	213,04	20131021	4,62
22	25	238,3	223,11	20131022	5,09
23	25	248,3	233,17	20131023	5,60
24	25	258,4	243,23	20131024	6,18
25	25	268,5	253,33	20131025	6,67
26	25	278,6	263,40	20131026	7,21
27	25	288,6	273,40	20131027	7,81
28	25	298,7	283,56	20131028	8,43
29	25	308,8	293,65	20131029	9,07
30	25	318,9	303,75	20131030	9,73
31	25	329,0	313,85	20131031	19,42
32	25	339,1	323,91	20131032	11,13
33	25	349,2	334,01	20131033	11,87
34	25	359,3	344,10	20131034	12,63
35	25	369,4	354,20	20131035	13,41
36	25	379,5	364,30	20131036	14,22
37	25	389,5	374,39	20131037	15,04
38	25	399,6	384,49	20131038	15,90
39	25	409,7	394,59	20131039	16,77
40	25	419,8	404,68	20131040	17,67
41	30	429,9	414,78	20131041	18,59
42	30	440,0	424,88	20131042	19,54
43	30	450,1	434,97	20131043	20,50

DUPLEX

Z	D ₁	d _e	d _p	P. NUMBER	kg.
8	20	98,10	82,96	20231008	1,28
9	20	108,00	92,84	20231009	1,74
10	20	117,90	102,74	20231010	2,28
11	20	127,80	112,68	20231011	2,89
12	20	137,80	122,68	20231012	3,56
13	20	147,80	132,65	20231013	4,31
14	20	157,80	142,68	20231014	5,12
15	20	167,90	152,72	20231015	6,00
16	25	177,90	162,75	20231016	6,78
17	25	187,90	172,78	20231017	7,80
18	25	198,00	182,85	20231018	8,89
19	25	208,10	192,91	20231019	10,05
20	25	218,10	202,98	20231020	11,27
21	25	228,20	213,04	20231021	12,56
22	25	238,30	223,11	20231022	13,93
23	25	248,30	233,17	20231023	15,36
24	25	258,40	243,23	20231024	16,86
25	25	268,50	253,33	20231025	18,43
26	25	278,60	263,40	20231026	20,07
27	25	288,60	273,40	20231027	21,77
28	25	298,70	283,56	20231028	23,56
29	25	308,80	293,65	20231029	25,39
30	25	318,90	303,75	20231030	27,30
31	25	329,00	313,85	20231031	29,29
32	25	339,10	323,91	20231032	31,34
33					
34	25	359,30	344,10	20231034	35,64
35	25	369,40	354,20	20231035	37,90
36					
37					
38	30	399,60	384,49	20231038	45,08
39					
40	30	419,80	404,68	20231040	50,21
41					
42	30	440,00	424,88	20231042	55,62
43					

MATERIAL **FE / C45**

Ask for specific needs.

CAD drawings available on our site
www.chiaravalli.com

Quantity, availability and prices
on B2B Chiaravalli





1" 1/4 x 3/4"

PLATEWHEEL

Tooth radius r_3	32	mm
Radius width C	3,5	mm
Plate tooth width B_1	18,5	mm
Plate tooth width b_1	18,2	mm
Plate tooth width B_2	54,6	mm
Plate tooth width B_3	91	mm

CHAIN

Pitch	31,75	mm
Inner width	19,56	mm
Roller \varnothing	19,05	mm

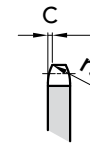
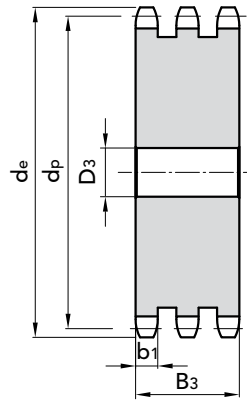

PLATEWHEELS 1" 1/4 x 3/4"
for roller chains in compliance
with DIN 8187 - ISO/R 606

TRIPLEX

Z	D ₁	d _e	d _p	P. NUMBER	kg.	Z	D ₁	d _e	d _p	P. NUMBER	kg.
8	20	98,10	82,96	20331008	2,02	44					
9	20	108,0	92,84	20331009	2,79	45	40	470,3	455,17	20331045	105,96
10	20	117,9	102,74	20331010	3,77	46					
11	20	127,8	112,68	20331011	4,53	48					
12	20	137,8	122,68	20331012	5,64	50	40	520,8	505,65	20331050	132,13
13	20	147,8	132,65	20331013	4,87	51					
14	20	157,8	142,68	20331014	8,20	52					
15	20	167,9	152,72	20331015	9,65	54					
16	25	177,9	162,75	20331016	11,07	55	40	571,3	556,16	20331055	161,16
17	25	187,9	172,78	20331017	12,75	56					
18	25	198,0	182,85	20331018	14,54	57	40	591,5	576,36	20331057	173,58
19	25	208,1	192,91	20331019	16,45	58					
20	25	218,1	202,98	20331020	18,47	60	40	621,8	606,65	20331060	193,06
21	25	228,2	213,04	20331021	20,62	64					
22	25	238,3	223,11	20331022	22,87	65	40	672,3	657,16	20331065	227,83
23	25	248,3	233,17	20331023	25,24	70	40	722,8	707,67	20331070	265,46
24	25	258,4	243,23	20331024	27,72	75					
25	25	268,5	253,33	20331025	30,32	76	40	783,5	768,32	20331076	314,39
26	25	278,6	263,40	20331026	33,03	80	40	823,9	808,72	20331080	340,0
27	25	288,6	273,40	20331027	35,86	85					
28	25	298,7	283,56	20331028	38,80	90					
29						95	40	975,4	960,28	20331095	420,0
30	25	318,9	303,75	20331030	45,03	100					
31						114	40	1167,4	1152,26	20331114	720,16
32	25	339,1	323,91	20331032	51,72						
33	25	349,2	334,01	20331033	55,17						
34	25	359,3	344,10	20331034	58,86						
35	25	369,4	354,20	20331035	62,60						
36	30	379,5	364,30	20331036	66,46						
37	30	389,5	374,39	20331037	70,37						
38	30	399,6	384,49	20331038	74,52						
39											
40	30	419,8	404,68	20331040	83,04						
41											
42											
43											

MATERIAL **FE / C45**

Ask for specific needs.

CAD drawings available on our site
www.chiaravalli.com

Quantity, availability and prices
on B2B Chiaravalli





PLATEWHEELS 1" 1/2 x 1"
for roller chains in compliance
with DIN 8187 - ISO/R 606

1" 1/2 x 1"

PLATEWHEEL

Tooth radius r_3	38	mm
Radius width \bar{C}	4	mm
Plate tooth width B_1	24,1	mm
Plate tooth width b_1	23,6	mm
Plate tooth width B_2	72	mm
Plate tooth width B_3	120,3	mm

CHAIN

Pitch	38,1	mm
Inner width	25,4	mm
Roller \varnothing	25,4	mm

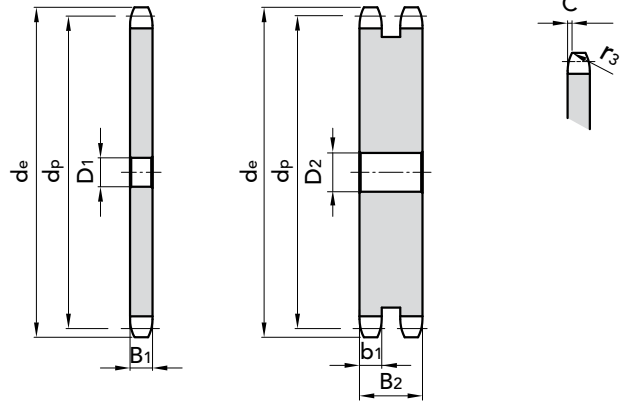

SIMPLEX

Z	D ₁	d _e	d _p	P. NUMBER	kg.
8	20	115,0	99,55	20138008	1,00
9	20	126,4	111,40	20138009	1,32
10	20	138,0	123,29	20138010	1,69
11	20	150,0	135,21	20138011	2,07
12	20	162,0	147,22	20138012	2,53
13	20	174,2	159,18	20138013	3,03
14	20	186,2	171,22	20138014	3,57
15	20	198,2	183,26	20138015	4,16
16	25	210,3	195,30	20138016	4,79
17	25	222,3	207,34	20138017	5,47
18	25	234,3	219,42	20138018	6,19
19	25	246,5	231,49	20138019	6,95
20	25	258,6	243,57	20138020	7,76
21	25	270,6	255,65	20138021	8,57
22	25	282,7	267,73	20138022	9,46
23	25	294,8	279,80	20138023	10,40
24	25	306,8	291,88	20138024	11,38
25	25	319,0	304,00	20138025	12,41
26	30	331,0	316,08	20138026	13,47
27	30	343,2	328,19	20138027	14,59
28	30	355,2	340,27	20138028	15,74
29	30	367,3	352,38	20138029	16,94
30	30	379,5	364,50	20138030	18,91
31	30	391,6	376,62	20138031	19,47
32	30	403,7	388,69	20138032	20,80
33	30	415,8	400,81	20138033	22,18
34	30	427,8	412,93	20138034	23,60
35	30	440,0	425,04	20138035	25,06
36	30	452,0	437,16	20138036	26,60
37	30	464,2	449,27	20138037	28,12
38	30	476,2	461,39	20138038	29,71
39					
40	30	500,6	485,62	20138040	33,03
41	30	512,6	497,74	20138041	34,75
42	30	524,7	509,85	20138042	36,52
43	30	536,8	521,97	20138043	37,00

DUPLEX

Z	D ₁	d _e	d _p	P. NUMBER	kg.
8	25	115,00	99,55	20238008	2,31
9	25	126,40	111,40	20238009	3,18
10	25	138,00	123,29	20238010	4,19
11	25	150,00	135,21	20238011	5,33
12	25	162,00	147,22	20238012	6,59
13	25	174,20	159,18	20238013	7,99
14	25	186,20	171,22	20238014	9,52
15	25	198,20	183,26	20238015	11,18
16	25	210,30	195,30	20238016	12,85
17	25	222,30	207,34	20238017	14,77
18	25	234,30	219,42	20238018	16,82
19	25	246,50	231,49	20238019	19,00
20	25	258,60	243,57	20238020	21,31
21	25	270,60	255,65	20238021	23,75
22	25	282,70	267,73	20238022	26,33
23	25	294,80	279,80	20238023	29,03
24	25	306,80	291,88	20238024	31,86
25	25	319,00	304,00	20238025	34,83
26	30	331,00	316,08	20238026	37,93
27	30	343,20	328,19	20238027	41,15
28	30	355,20	340,27	20238028	44,51
29	30	367,30	352,38	20238029	48,00
30	30	379,50	364,50	20238030	51,61
31	30	391,60	376,62	20238031	55,05
32	30	403,70	388,69	20238032	58,93
33	30	415,80	400,81	20238033	62,94
34	30	427,80	412,93	20238034	67,08
35	30	440,00	425,04	20238035	71,35
36	30	452,00	437,16	20238036	75,75
37	30	464,20	449,27	20238037	80,28
38	30	476,20	461,39	20238038	84,95
39					
40	30	500,60	485,62	20238040	94,66
41					
42					
43					

MATERIAL **FE / C45**

Ask for specific needs.

CAD drawings available on our site
www.chiaravalli.com

Quantity, availability and prices
on B2B Chiaravalli





1" 1/2 x 1"

PLATEWHEEL

Tooth radius r_3	38	mm
Radius width C	4	mm
Plate tooth width B_1	24,1	mm
Plate tooth width b_1	23,6	mm
Plate tooth width B_2	72	mm
Plate tooth width B_3	120,3	mm

CHAIN

Pitch	38,1	mm
Inner width	25,4	mm
Roller \varnothing	25,4	mm

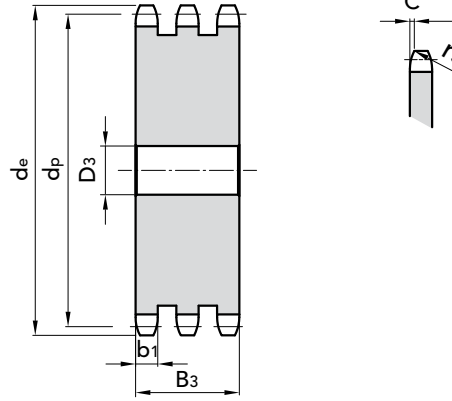

PLATEWHEELS 1" 1/2 x 1"
for roller chains in compliance
with DIN 8187 - ISO/R 606

TRIPLEX

Z	D ₁	d _e	d _p	P. NUMBER	kg.	Z	D ₁	d _e	d _p	P. NUMBER	kg.
8	25	115,0	99,55	20338008	3,67	44					
9	25	126,4	111,40	20338009	5,10	45	40	561,2	546,20	20338045	201,37
10	25	138,0	123,29	20338010	6,75	46					
11	25	150,0	135,21	20338011	8,42	47					
12	25	162,0	147,22	20338012	10,50	48	40	597,4	582,55	20338048	230,56
13	25	174,2	159,18	20338013	12,81	49					
14	25	186,2	171,22	20338014	15,33	50	40	621,7	606,78	20338050	251,11
15	25	198,2	183,26	20338015	18,08	51					
16	25	210,3	195,30	20338016	21,04	52					
17	25	222,3	207,34	20338017	24,22	53					
18	25	234,3	219,42	20338018	27,61	54					
19	25	246,5	231,49	20338019	31,23	55	40	682,3	667,40	20338055	265,0
20	25	258,6	243,57	20338020	35,06	56					
21	30	270,6	255,65	20338021	38,60	57	40	706,5	691,63	20338057	329,92
22	30	282,7	267,73	20338022	42,87	58					
23	30	294,8	279,80	20338023	47,36	59					
24	30	306,8	291,88	20338024	52,07	60	40	742,8	727,97	20338060	366,97
25	30	319,0	304,00	20338025	56,99	62					
26	30	331,0	316,08	20338026	62,14	64					
27	30	343,2	328,19	20338027	67,50	65					
28	30	355,2	340,27	20338028	73,08	66					
29						68					
30	40	379,5	364,50	20338030	84,90	70					
31						72					
32	40	403,7	388,69	20338032	97,59	75					
33						76	40	936,9	921,98	20338076	597,76
34						80					
35	40	440,0	425,04	20338035	118,26	85					
36						95					
37											
38	40	476,2	416,39	20338038	140,90						
39											
40	40	500,6	485,62	20338040	158,08						
41											
42											
43											

MATERIAL **FE / C45**

Ask for specific needs.

CAD drawings available on our site
www.chiaravalli.com

Quantity, availability and prices
on B2B Chiaravalli





PLATEWHEELS 1" 3/4 x 1" 1/4
for roller chains in compliance
with DIN 8187 - ISO/R 606

1" 3/4 x 1" 1/4

PLATEWHEEL

Tooth radius r_3	44	mm
Radius width \bar{C}	5	mm
Plate tooth width B_1	29,4	mm
Plate tooth width b_1	28,8	mm
Plate tooth width B_2	88,4	mm
Plate tooth width B_3	148	mm

CHAIN

Pitch	44,45	mm
Inner width	30,99	mm
Roller \varnothing	27,94	mm

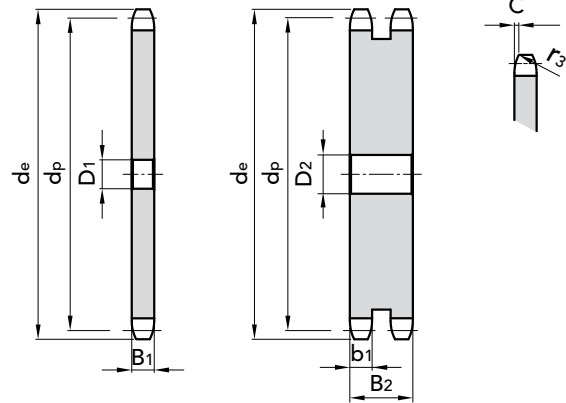

SIMPLEX

Z	D ₁	d _e	d _p	P. NUMBER	kg.
8	25	132,0	116,15	20144008	1,71
9	25	148,4	129,96	20144009	2,26
10	25	162,3	143,85	20144010	2,88
11	25	176,3	157,77	20144011	3,53
12	25	189,5	171,74	20144012	4,29
13	25	204,2	185,75	20144013	5,12
14	25	218,2	199,76	20144014	6,03
15	25	232,3	213,79	20144015	7,01
16	30	246,3	227,84	20144016	8,02
17	30	260,0	241,91	20144017	9,14
18	30	274,0	255,98	20144018	10,34
19	30	289,0	270,06	20144019	11,61
20	30	303,0	284,15	20144020	12,95
21	30	317,0	298,24	20144021	14,37
22	30	331,0	312,34	20144022	15,86
23	30	345,0	326,44	20144023	17,42
24	30	359,0	340,55	20144024	19,05
25	30	373,0	354,66	20144025	20,76
26	30	387,0	368,77	20144026	22,54
27	30	401,4	382,88	20144027	24,39
28	30	416,0	397,00	20144028	26,32
29					
30	30	444,0	425,24	20144030	30,38
31					
32	30	472,0	453,49	20144032	34,74
33					
34	30	500,0	481,75	20144034	39,38
35	30	514,0	495,88	20144035	41,82
36	30	529,0	510,01	20144036	44,32
37					
38	30	557,0	538,27	20144038	49,55
39					
40	30	585,0	566,54	20144040	55,07
45	30	656,0	637,22	20144045	70,13
50	30	726,0	707,91	20144050	87,01
57	40	825,0	806,90	20144057	113,56

DUPLEX

Z	D ₁	d _e	d _p	P. NUMBER	kg.
8	25	132,00	116,15	20244008	4,01
9	25	148,40	129,96	20244009	5,48
10	25	162,3	143,85	20244010	7,17
11	25	176,30	157,77	20244011	8,92
12	25	189,50	171,74	20244012	11,04
13	25	204,20	185,75	20244013	13,38
14	25	218,20	199,76	20244014	15,94
15	25	232,30	213,79	20244015	18,72
16	30	246,30	227,84	20244016	21,71
17	30	260,00	241,91	20244017	24,92
18	30	274,00	255,98	20244018	28,36
19	30	289,00	270,06	20244019	32,00
20	30	303,00	284,15	20244020	35,87
21	30	317,00	298,24	20244021	39,96
22	30	331,00	312,34	20244022	44,26
23	30	345,00	326,44	20244023	48,78
24	30	359,00	340,55	20244024	52,85
25	30	373,00	354,66	20244025	58,50
26	30	387,00	368,77	20244026	63,28
27					
28	30	416,00	397,00	20244028	74,29
29					
30	30	444,00	425,24	20244030	86,17
31					
32					
33					
34					
35	30	514,00	495,88	20244035	119,69
36					
37					
38	30	557,00	538,27	20244038	142,42
39					
40	30	585,00	566,54	20244040	158,67
45	30	656,00	637,22	20244045	203,10
50	30	726,00	707,91	20244050	252,99
57	40	825,00	806,90	20244057	332,00

MATERIAL **FE / C45**

Ask for specific needs.

CAD drawings available on our site
www.chiaravalli.com

Quantity, availability and prices
on B2B Chiaravalli





1" 3/4 x 1" 1/4

PLATEWHEEL

Tooth radius r_3	44	mm
Radius width C	5	mm
Plate tooth width B_1	29,4	mm
Plate tooth width b_1	28,8	mm
Plate tooth width B_2	88,4	mm
Plate tooth width B_3	148	mm

CHAIN

Pitch	44,45	mm
Inner width	30,99	mm
Roller \varnothing	27,94	mm

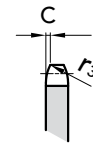
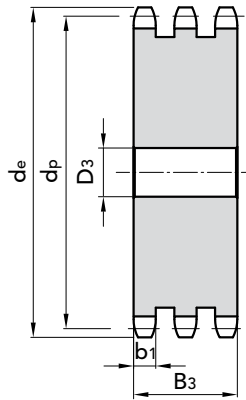

PLATEWHEELS 1" 3/4 x 1" 1/4
for roller chains in compliance
with DIN 8187 - ISO/R 606

TRIPLEX

Z	D ₁	d _e	d _p	P. NUMBER	kg.	Z	D ₁	d _e	d _p	P. NUMBER	kg.
8	25	132,0	116,15	20344008	6,39	60					
9	25	148,4	129,96	20344009	8,80	76	40	1095,5	1075,62	20344076	1000,97
10	25	162,3	143,85	20344010	11,56						
11	30	176,3	157,77	20344011	14,44						
12	30	189,5	171,74	20344012	17,93						
13	30	204,2	185,75	20344013	21,79						
14	30	218,2	199,76	20344014	26,02						
15	30	232,3	213,79	20344015	30,61						
16	30	246,3	227,84	20344016	35,57						
17	30	260,0	241,91	20344017	40,89						
18	30	274,0	255,98	20344018	46,58						
19	30	289,0	270,06	20344019	52,64						
20	30	303,0	284,15	20344020	59,06						
21	30	317,0	298,24	20344021	65,20						
22											
23	30	345,0	326,44	20344023	79,87						
24											
25	40	373,0	354,66	20344025	95,99						
26											
27											
28											
29											
30	40	444,0	425,24	20344030	142,70						
31											
32											
33											
34											
35											
36											
37											
38	40	557,0	538,27	20344038	236,43						
39											
40	40	585,0	566,54	20344040	263,52						
45	40	656,0	637,22	20344045	337,73						
50											
57	40	825,0	806,90	20344057	552,76						

MATERIAL **FE / C45**

Ask for specific needs.

CAD drawings available on our site
www.chiaravalli.com

Quantity, availability and prices
on B2B Chiaravalli





PLATEWHEELS 2" x 1" 1/4
for roller chains in compliance
with DIN 8187 - ISO/R 606

2" x 1" 1/4

PLATEWHEEL

Tooth radius r_3	51	mm
Radius width \bar{C}	5	mm
Plate tooth width B_1	29,4	mm
Plate tooth width b_1	28,8	mm
Plate tooth width B_2	87,4	mm
Plate tooth width B_3	146	mm

CHAIN

Pitch	50,8	mm
Inner width	30,99	mm
Roller \varnothing	29,21	mm

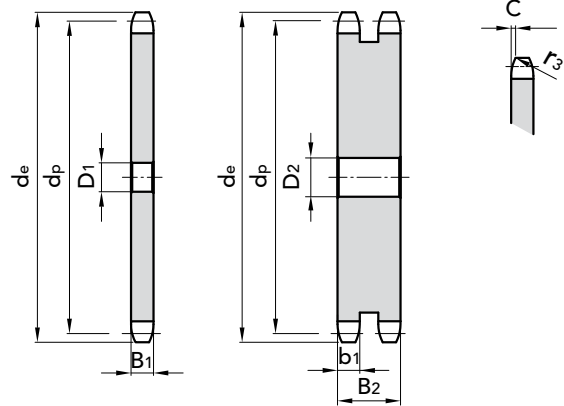

SIMPLEX

Z	D ₁	d _e	d _p	P. NUMBER	kg.
8	25	153,2	132,69	20150008	2,27
9	25	169,0	148,54	20150009	2,99
10	25	185,0	164,44	20150010	3,81
11	30	200,8	180,34	20150011	4,67
12	30	216,8	196,29	20150012	5,67
13	30	232,8	212,29	20150013	6,77
14	30	248,8	228,29	20150014	7,97
15	30	264,8	244,30	20150015	9,26
16	30	280,9	260,40	20150016	10,64
17	30	296,9	276,40	20150017	12,12
18	30	313,0	292,55	20150018	13,69
19	30	329,1	308,66	20150019	15,36
20	30	345,2	324,71	20150020	16,99
21	30	361,3	340,82	20150021	18,85
22	30	377,5	356,98	20150022	20,80
23	30	393,6	373,08	20150023	22,85
24	30	409,7	389,18	20150024	24,99
25	30	425,8	405,33	20150025	27,23
26	30	441,9	421,44	20150026	29,56
27					
28	30	474,2	453,69	20150028	34,51
29					
30	30	506,5	486,00	20150030	39,84
32	30	538,8	518,28	20150032	45,54
35	30	589,5	566,72	20150035	54,81
38	30	635,5	615,14	20150038	64,93
40	40	670,3	647,49	20150040	72,16
45	40	751,0	728,26	20150045	91,87
50	40	831,8	809,04	20150050	113,96
57	40	945,0	922,17	20150057	148,86
60	40	993,4	970,63	20150060	165,24
76	40	1252,0	1229,28	20150076	267,00

DUPLEX

Z	D ₁	d _e	d _p	P. NUMBER	kg.
8	25	153,20	132,69	20250008	5,53
9	25	169,00	148,54	20250009	7,46
10	25	185,00	164,44	20250010	9,68
11	30	200,80	180,34	20250011	11,86
12	30	216,80	196,29	20250012	14,64
13	30	232,80	212,29	20250013	17,70
14	30	248,80	228,29	20250014	21,05
15	30	264,80	244,30	20250015	24,68
16	30	280,90	260,40	20250016	28,38
17	30	296,90	276,40	20250017	32,57
18	30	313,00	292,55	20250018	37,05
19	30	329,10	308,66	20250019	41,80
20	30	345,20	324,71	20250020	46,84
21	30	361,30	340,82	20250021	52,15
22	30	377,50	356,98	20250022	57,75
23	30	393,60	373,08	20250023	63,63
24	30	409,70	389,18	20250024	69,80
25	30	425,80	405,33	20250025	76,24
26	30	441,90	421,44	20250026	82,97
27					
28	30	474,20	453,69	20250028	97,27
29					
30	40	506,50	486,00	20250030	112,70
32					
35	40	589,50	566,72	20250035	156,19
38	40	635,50	615,14	20250038	185,67
40	40	670,30	647,49	20250040	206,73
45	40	751,00	728,26	20250045	265,32
50	40	831,80	809,04	20250050	328,95
57	40	945,00	922,17	20250057	431,27
60	40	993,40	970,63	20250060	474,00
76	40	1252,00	1229,28	20250076	757,78

MATERIAL **FE / C45**

Ask for specific needs.

CAD drawings available on our site
www.chiaravalli.com

Quantity, availability and prices
on B2B Chiaravalli





2" x 1" 1/4

PLATEWHEEL

Tooth radius r_3	51	mm
Radius width C	5	mm
Plate tooth width B_1	29,4	mm
Plate tooth width b_1	28,8	mm
Plate tooth width B_2	87,4	mm
Plate tooth width B_3	146	mm

CHAIN

Pitch	50,8	mm
Inner width	30,99	mm
Roller \varnothing	29,21	mm

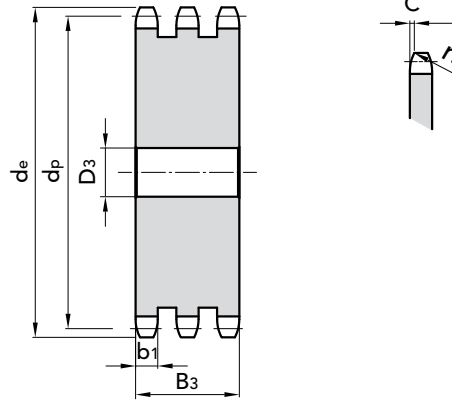

PLATEWHEELS 2" x 1" 1/4
for roller chains in compliance
with DIN 8187 - ISO/R 606

TRIPLEX

Z	D ₁	d _e	d _p	P. NUMBER	kg.
8	25	153,2	132,69	20350008	8,83
9	25	169,0	148,54	20350009	11,99
10	25	185,0	164,44	20350010	15,63
11	30	200,8	180,34	20350011	19,20
12	30	216,8	196,29	20350012	23,78
13	30	232,8	212,29	20350013	28,83
14	30	248,8	228,29	20350014	34,35
15	30	264,8	244,30	20350015	40,34
16	30	280,9	260,40	20350016	46,47
17	30	296,9	276,40	20350017	53,40
18	30	313,0	292,55	20350018	60,80
19	30	329,1	308,66	20350019	68,68
20	30	345,2	324,71	20350020	77,02
21	40	361,3	340,82	20350021	85,84
22					
23	40	393,6	373,08	20350023	104,88
24					
25	40	425,8	405,33	20350025	125,81
26					
27					
28					
29					
30	40	506,5	486,00	20350030	186,37
32					
35	40	589,5	566,72	20350035	258,69
38	40	635,5	615,14	20350038	307,73
40					
45	40	751,0	728,26	20350045	438,64
50	40	831,8	809,04	20350050	549,27
57	40	945,0	922,17	20350057	716,72
60	40	993,4	970,63	20350060	1006,0
76	40	1252,0	1229,28	20350076	1295,64

MATERIAL **FE / C45**
Ask for specific needs.

CAD drawings available on our site
www.chiaravalli.com

Quantity, availability and prices
on B2B Chiaravalli





PLATEWHEELS ASA 35 pitch 3/8" x 3/16" for roller chains in compliance with DIN 8188 - ISO/R 606 - ANSI B 29.1

pitch 3/8" x 3/16" ASA 35

PLATEWHEEL

Tooth radius r_3	10	mm
Radius width C	1,2	mm
Plate tooth width B_1	4,4	mm
Plate tooth width b_1	4,3	mm
Plate tooth width B_2	14,4	mm

CHAIN

Pitch	9,525	mm
Inner width	4,77	mm
Roller \varnothing	5,08	mm

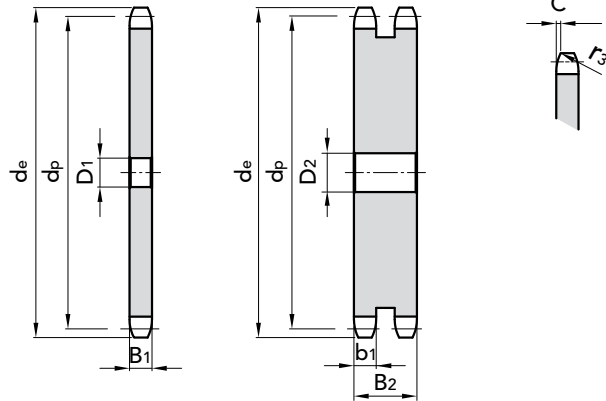

SIMPLEX

Z	D ₁	d _e	d _p	P. NUMBER	kg.
9	8	31,50	27,85	21103009	0,015
11	8	38,69	33,80	21103011	0,020
12	8	41,68	36,80	21103012	0,029
15					
16	10	53,70	48,82	21103016	0,054
18	10	59,73	54,85	21103018	0,069
20					
22	12	71,81	66,93	21103022	0,107
25					
26	12	83,90	79,02	21103026	0,150
30	12	96,00	91,12	21103030	0,250
32	12	102,06	97,09	21103032	0,290
34	12	108,11	103,23	21103034	0,310
35	12	110,2	105,3	21103035	0,320
36	12	114,2	109,29	21103036	0,340
38	12	120,2	115,34	21103038	0,360
40	12	126,3	121,40	21103040	0,385
42	12	132,0	127,5	21103042	0,410
44	12	138,0	134,0	21103044	0,448
45					
46	16	144,0	140,0	21103046	0,430
48	16	150,5	145,64	21103048	0,540
54	20	165,0	161,0	21103054	0,640
57	20	177,8	172,91	21103057	0,710
72	20	223,0	218,0	21103072	1,195
76					
80	20	247,0	242,0	21103080	1,400
85	25	262,0	257,0	21103085	1,710
90	25	278,0	273,0	21103090	2,000
95	25	293,0	289,0	21103095	2,150
114	25	350,0	346,0	21103114	4,860
120	20	384,0	380,0	21103120	5,420

DUPLEX

Z	D ₁	d _e	d _p	P. NUMBER	kg.
9					
11					
12					
15					
16					
18					
20					
22					
25					
26					
30	12	96,00	91,12	21203030	0,80
32					
34					
35					
36					
38	14	120,22	115,34	21203038	1,00
40					
42					
44	16	138,9	133,5	21203044	1,20
45	16	141,43	136,55	21203045	1,47
46					
48					
54	16	169,3	163,8	21203054	2,162
57	16	177,79	172,91	21203057	2,35
70	16	217,8	212,3	21203070	3,70
72					
76	16	235,37	230,49	21203076	4,10

MATERIAL **FE / C45**

Ask for specific needs.

CAD drawings available on our site
www.chiaravalli.com

Quantity, availability and prices
 on B2B Chiaravalli





pitch 1/2" x 5/16" ASA 40

PLATEWHEEL

Tooth radius r_3	13,5	mm
Radius width \bar{C}	1,6	mm
Plate tooth width B_1	7,4	mm
Plate tooth width b_1	7,2	mm
Plate tooth width B_2	21,6	mm
Plate tooth width B_3	36	mm

CHAIN

Pitch	12,7	mm
Inner width	7,94	mm
Roller \varnothing	7,94	mm

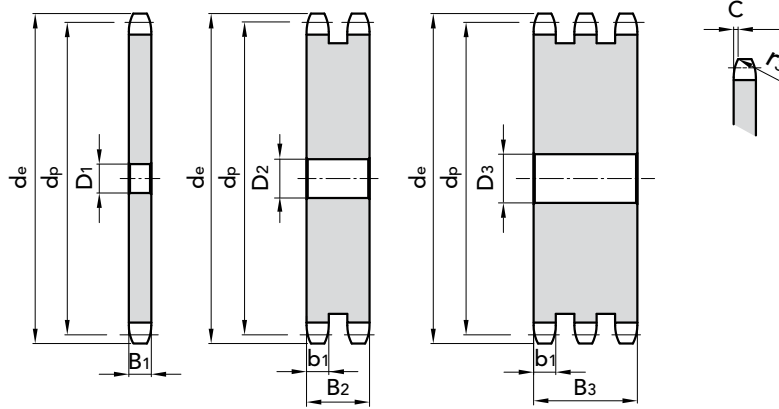

SIMPLEX

Z	D ₁	d _e	d _p	P. NUMBER	kg.
8	8	38,00	33,00	21104008	0,035
9					
11					
12					
13	10	59,63	52,68	21104013	0,102
14					
17					
19					
20	12	87,70	81,20	21104020	0,260
21					
22	12	95,80	89,24	21104022	0,315
23	12	99,85	93,05	21104023	0,340
25	14	107,88	101,34	21104025	0,400
26	14	111,94	105,36	21104026	0,500
30					
31					
32					
33	16	140,62	133,4	21104033	0,730
36	16	152,28	145,72	21104036	0,880
37	16	156,30	149,8	21104037	1,045
38	16	160,40	153,79	21104038	1,080
40					
41	20	173,04	165,91	21104041	1,146
42	20	176,50	169,94	21104042	1,200
44	20	185,19	178,0	21104044	1,325
45	20	188,62	181,95	21104045	1,390
46					
48	20	200,70	194,18	21104048	1,588
50	20	209,48	202,3	21104050	1,727
54	20	226,00	219,0	21104054	2,024
57	20	237,10	230,54	21104057	2,210
72	20	207,60	290,2	21104072	3,630
76	20	313,90	307,32	21104076	4,100
80	20	331,00	324,0	21104080	4,489
85	20	350,20	343,7	21104085	5,095
90					
95	20	390,70	384,11	21104095	6,387
114	20	465,00	461	21104114	9,240

DUPLEX

Z	D ₁	d _e	d _p	P. NUMBER	kg.
8					
9					
11					
12	10	41,70	36,80	21204012	0,210
13					
14					
17					
19					
20					
21					
22					
23					
25					
26					
30					
31					
32					
33					
36	20	152,28	145,70	21204036	2,300
37					
38	20	160,40	153,79	21204038	2,780
40	20	168,43	161,87	21204040	3,000
41					
42					
44	20	185,19	178,00	21204044	3,600
45	20	188,62	181,95	21204045	3,900
46					
48					
50	20	209,48	202,30	21204050	4,980
54					
57	25	237,10	230,54	21204057	5,450
72					
76	25	313,90	307,32	21204076	12,00
80					
85					
90					
95	25	390,67	384,11	21204095	22,40
114	25	467,40	461,00	21204114	31,85

TRIPLEX

Z	D ₁	d _e	d _p	P. NUMBER	kg.
8					
9					
11					
12					
13					
14					
17					
19					
20	16	128,06	121,50	21304020	1,10
21					
22					
23					
25					
26					
30	20	96,00	91,12	21304030	3,00
31					
32					
33					
36					
37					
38	25	160,40	153,79	21304038	4,00
40	25	176,50	169,94	21304040	4,84
41					
42					
44					
45	25	188,62	181,95	21304045	6,00
46					
48	25	200,70	194,18	21304048	7,00
50	25	209,48	202,30	21304050	8,19
54					
57	25	237,10	230,54	21304057	10,00
72					
76	25	313,90	307,32	21304076	20,00
80					
85					
90					
95					
114					

MATERIAL **FE / C45**

Ask for specific needs.

CAD drawings available on our site
www.chiaravalli.com

Quantity, availability and prices
 on B2B Chiaravalli



PLATEWHEELS ASA 40 pitch 1/2" x 5/16" for roller chains in compliance with DIN 8188 - ISO/R 606 - ANSI B 29.1



PLATEWHEELS ASA 50 pitch 5/8" x 3/8" for roller chains in compliance with DIN 8188 - ISO/R 606 - ANSI B 29.1

pitch 5/8" x 3/8"

PLATEWHEEL

Tooth radius r_3	17	mm
Radius width C	2	mm
Plate tooth width B_1	9	mm
Plate tooth width b_1	8,8	mm
Plate tooth width B_2	26,9	mm
Plate tooth width B_3	45	mm

CHAIN

Pitch	15,875	mm
Inner width	9,52	mm
Roller \varnothing	10,16	mm

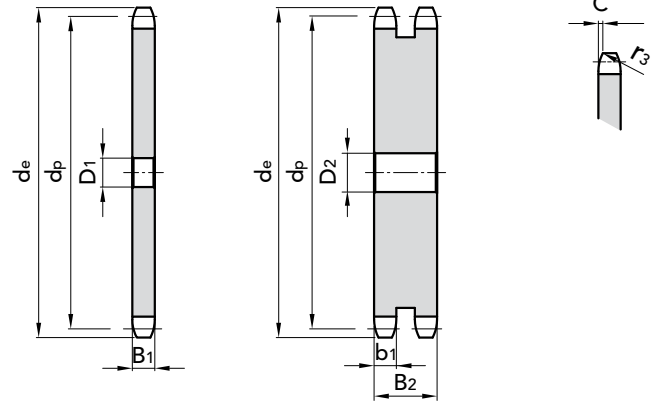

SIMPLEX

DUPLEX

Z	D ₁	d _e	d _p	P. NUMBER	kg.	Z	D ₁	d _e	d _p	P. NUMBER	kg.	Z	D ₁	d _e	d _p	P. NUMBER	kg.	Z	D ₁	d _e	d _p	P. NUMBER	kg.	
8	10	47,0	41,48	20115008	0,06	44	20	230,0	222,53	20115044	2,63	8						44						
9	10	52,6	46,42	20115009	0,09	45	20	235,0	227,58	20115045	2,75	9						45	20	235,00	227,58	21205045	7,27	
10	10	57,5	51,37	20115010	0,11	46	20	240,1	232,63	20115046	2,88	10						46						
11	10	63,0	56,34	20115011	0,14	47	20	245,1	237,68	20115047	3,01	11						47						
12	10	68,0	61,34	20115012	0,17	48	20	250,2	242,73	20115048	3,14	12	14	68,00	61,34	21205012	0,40	48						
13	10	73,0	66,32	20115013	0,20	49	20	255,2	247,78	20115049	3,28	13	14	73,00	66,32	21205013	0,60	49						
14	10	78,0	71,34	20115014	0,23	50	20	260,3	252,82	20115050	3,42	14						50						
15	10	83,0	76,36	20115015	0,27	51	20	265,3	257,87	20115051	3,56	15						51						
16	12	88,0	81,37	20115016	0,31	52	20	270,4	262,92	20115052	3,70	16	16	88,00	81,37	21205016	0,80	52						
17	12	93,0	86,39	20115017	0,36	53	20	275,4	267,97	20115053	3,85	17						53						
18	12	98,0	91,42	20115018	0,41	54	20	280,5	273,03	20115054	4,00	18						54						
19	12	103,3	96,45	20115019	0,46	55	20	285,5	278,08	20115055	4,15	19						55						
20	12	108,4	101,49	20115020	0,51	56	25	290,6	283,13	20115056	4,30	20						56						
21	12	113,4	106,52	20115021	0,57	57	25	296,0	288,18	20115057	4,46	21						57	25	296,00	288,18	21205057	13,00	
22	12	118,0	111,55	20115022	0,62	58	25	300,7	293,23	20115058	4,62	22						58						
23	12	123,4	116,58	20115023	0,69	59	25	305,7	298,27	20115060	4,80	23	16	123,40	116,58	21205023	1,10	59						
24	12	128,3	121,62	20115024	0,75	60	25	310,8	303,32	20115062	4,95	24						60						
25	12	134,0	126,66	20115025	0,82	62	25	321,4	313,43	20115064	5,30	25						62						
26	16	139,0	131,70	20115026	0,88	64	25	331,5	323,53	20115065	5,65	26	16	139,00	131,70	21205026	2,30	64						
27	16	144,0	136,75	20115027	0,95	65	25	336,5	328,58	20115068	5,83	27	16	144,00	136,75	21205027	2,60	65						
28	16	148,7	141,78	20115028	1,03	66	25	341,6	333,63	20115070	6,00	28						66						
29	16	153,8	146,83	20115029	1,11	68	25	351,7	343,74	20115072	6,40	29						68						
30	16	158,8	151,87	20115030	1,19	70	25	361,8	353,84	20115075	6,79	30	20	158,80	151,87	21205030	3,27	70						
31	16	163,9	156,92	20115031	1,28	72	25	371,9	363,95	20115076	7,19	31						72	25	371,90	363,95	21205072	20,60	
32	16	168,9	161,95	20115032	1,36	75	25	387,1	379,09	20115078	7,81	32						75						
33	16	174,5	167,00	20115033	1,45	76	25	392,1	384,16	20115080	8,02	33						76	25	392,10	384,16	21205076	22,00	
34	16	179,0	172,05	20115034	1,55	78	25	402,2	394,25	20115085	8,46	34						78						
35	16	184,1	177,10	20115035	1,64	80	25	412,3	404,35	20115090	8,91	35						80						
36	20	189,1	182,15	20115036	1,73	85	30	437,6	429,62	20115095	10,06	36						85						
37	20	194,2	187,20	20115037	1,83	90	30	462,8	454,88	20115100	11,30	37						90						
38	20	199,2	192,24	20115038	1,94	95	30	488,5	480,14	20115110	12,61	38	20	199,20	192,24	21205038	5,30	95						
39	20	104,2	197,29	20115039	2,05	100	30	513,4	505,39	20115114	13,99	39						100						
40	20	209,3	202,34	20115040	2,16	110	30	563,9	555,92	20115120	17,00	40						110						
41	20	214,8	207,39	20115041	2,29	114	30	584,1	576,13	20115125	19,99	41						114						
42	20	219,9	212,44	20115042	2,39	120	30	614,4	606,45	20115008	22,17	42						120						
43	20	224,9	217,49	20115043	2,50	125	30	639,7	631,51	20115009	24,08	43						125						

MATERIAL **FE / C45**

Ask for specific needs.

CAD drawings available on our site
www.chiaravalli.com

Quantity, availability and prices
 on B2B Chiaravalli





pitch 5/8" x 3/8"

PLATEWHEEL

Tooth radius r_3	17	mm
Radius width \check{C}	2	mm
Plate tooth width B_1	9	mm
Plate tooth width b_1	8,8	mm
Plate tooth width B_2	26,9	mm
Plate tooth width B_3	45	mm

CHAIN

Pitch	15,875	mm
Inner width	9,52	mm
Roller \varnothing	10,16	mm

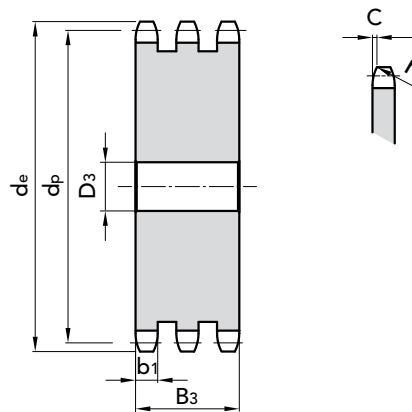

TRIPLEX

Z	D ₁	d _e	d _p	P. NUMBER	kg.	Z	D ₁	d _e	d _p	P. NUMBER	kg.
8						44	25	230,0	222,53	21305044	13,00
9						45	25	235,0	227,58	21305045	15,00
10						46					
11						47					
12						48					
13						49					
14						50	25	260,3	252,82	21305050	16,03
15						51					
16						52					
17						53					
18						54					
19						55					
20						56					
21						57	25	296,0	288,18	21305057	20,95
22						58					
23						59					
24						60					
25	20	134,0	126,66	21305025	3,7	62					
26						64					
27						65					
28						66					
29						68					
30	20	158,8	151,87	21305030	5,00	70					
31						72					
32	20	168,9	161,95	21305032	6,10	75					
33						76	30	392,1	384,16	21305076	25,00
34						78					
35						80					
36						85					
37						90					
38	25	199,2	192,24	21305038	8,90	95					
39						100					
40						110					
41	25	214,8	207,39	21305041	10,67	114					
42	25	219,9	212,44	21305042	12,00	120					
43						125					

MATERIAL **FE / C45**

Ask for specific needs.

CAD drawings available on our site
www.chiaravalli.com

Quantity, availability and prices
 on B2B Chiaravalli



PLATEWHEELS ASA 50 pitch 5/8" x 3/8" for roller chains in compliance with DIN 8188 - ISO/R 606 - ANSI B 29.1



PLATEWHEELS ASA 60 pitch 3/4" x 1/2" for roller chains in compliance with DIN 8188 - ISO/R 606 - ANSI B 29.1

pitch 3/4" x 1/2"

PLATEWHEEL

Tooth radius r_3	20	mm
Radius width C	2,4	mm
Plate tooth width B_1	12,0	mm
Plate tooth width b_1	11,8	mm
Plate tooth width B_2	34,6	mm
Plate tooth width B_3	57,4	mm

CHAIN

Pitch	19,05	mm
Inner width	12,7	mm
Roller \varnothing	11,91	mm

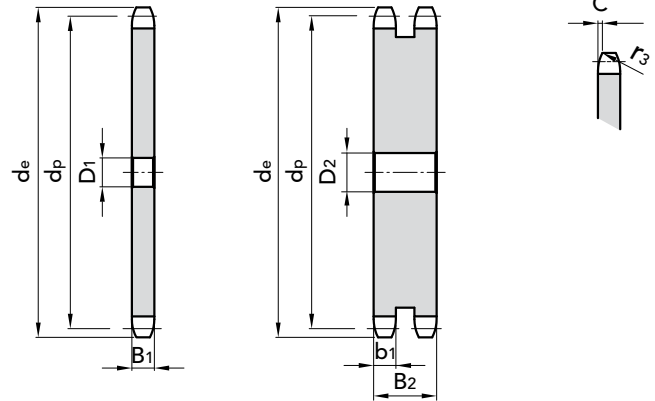

SIMPLEX

DUPLEX

Z	D ₁	d _e	d _p	P. NUMBER	kg.	Z	D ₁	d _e	d _p	P. NUMBER	kg.
8						8					
9	10	64,0	55,0	21106009	0,167	9					
10	12	71,54	61,65	21106010	0,210	10	16	71,54	61,65	21206010	0,50
11						11					
12	12	83,5	73,6	21106012	0,314	12					
13	14	89,6	79,6	21106013	0,375	13					
14	14	95,5	85,7	21106014	0,440	14					
15						15	16	101,52	91,12	21206015	1,31
16						16					
17	16	113,6	103,7	21106017	0,670	17					
18						18					
21						21	20	137,11	127,46	21206021	2,84
26						26					
27						27					
28						28	20	180,03	170,1	21206028	4,00
30						30					
31	20	196,7	188,3	21106031	2,350	31					
32						32					
33	20	208,9	200,5	21106033	2,600	33					
34	20	204,7	206,7	21106034	2,840	34					
38	20	240,6	230,69	21106038	3,200	38	25	240,60	230,69	21206038	10,60
40	20	252,7	242,80	21106040	3,950	40	25	252,70	242,80	21206040	11,20
42	25	265	255	21106042	4,350	42					
44	25	277,2	267,3	21106044	4,800	44					
45						45	25	282,98	273,09	21206045	14,20
46	25	289,4	279,3	21106046	5,240	46					
48	25	301,2	291,27	21106048	5,770	48					
57	25	355,7	345,81	21106057	8,010	57	25	355,70	345,81	21206057	23,65
72	30	447	437	21106072	13,09	72					
76	30	470,87	460,98	21106076	14,62	76	30	470,87	460,98	21206076	45,00
						90					
						95	30	586,06	576,17	21206095	66,90

MATERIAL **FE / C45**

Ask for specific needs.

CAD drawings available on our site
www.chiaravalli.com

Quantity, availability and prices
 on B2B Chiaravalli





pitch 3/4" x 1/2"

PLATEWHEEL

Tooth radius r_3	20	mm
Radius width \check{C}	2,4	mm
Plate tooth width B_1	12,0	mm
Plate tooth width b_1	11,8	mm
Plate tooth width B_2	34,6	mm
Plate tooth width B_3	57,4	mm

CHAIN

Pitch	19,05	mm
Inner width	12,7	mm
Roller \varnothing	11,91	mm

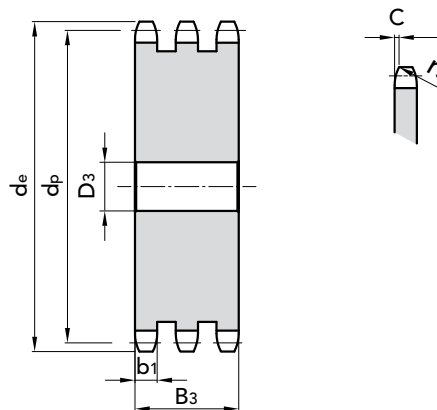

TRIPLEX

Z D₁ d_e d_p P. NUMBER kg.

13	16	89,60	79,60	21306013	1,00
14	16	95,5	85,70	21306014	1,91
18	20	119,60	109,71	21306018	3,31
19					
20	20	131,67	121,78	21306020	4,00
21	20	137,11	127,46	21306021	5,00
22	20	142,21	133,86	21306022	6,00
30	20	192,14	182,25	21306030	10,0
32					
38	25	240,6	230,69	21306038	13,00
40					
45	25	282,98	273,09	21306045	24,00
48	25	301,2	291,27	21306048	26,00
57	30	355,70	345,81	21306057	37,57
76	30	470,87	460,98	21306076	70,32
95					

MATERIAL **FE / C45**

Ask for specific needs.

CAD drawings available on our site
www.chiaravalli.com

Quantity, availability and prices
 on B2B Chiaravalli



PLATEWHEELS ASA 60 pitch 3/4" x 1/2" for roller chains in compliance with DIN 8188 - ISO/R 606 - ANSI B 29.1



PLATEWHEELS ASA 80 pitch 1" x 5/8" for roller chains in compliance with DIN 8188 - ISO/R 606 - ANSI B 29.1

pitch 1" x 5/8"

PLATEWHEEL

Tooth radius r_3	27	mm
Radius width \bar{C}	3,2	mm
Plate tooth width B_1	15,0	mm
Plate tooth width b_1	14,7	mm
Plate tooth width B_2	44,0	mm
Plate tooth width B_3	73,3	mm

CHAIN

Pitch	25,4	mm
Inner width	15,88	mm
Roller \varnothing	15,88	mm

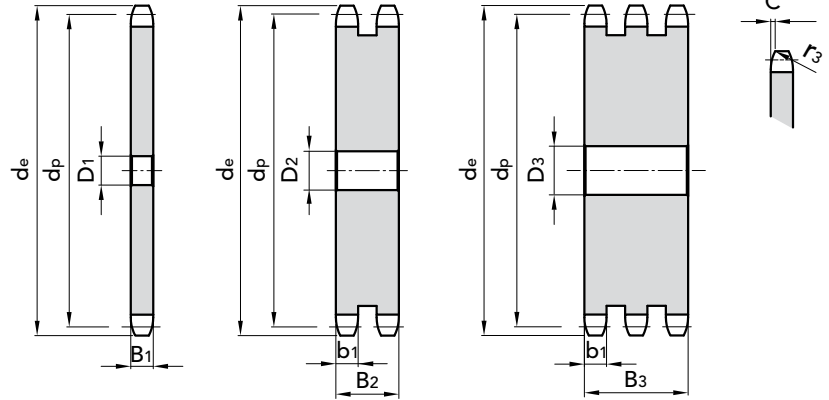

SIMPLEX

Z	D ₁	d _e	d _p	P. NUMBER	kg.
9	15	85,8	82,19	21108009	0,30
10	15	95,3	82,79	21108010	0,40
11	15	103,3	90,14	21108011	0,60
12	15	111,3	98,14	21108012	0,68
13	15	119,3	106,12	21108013	0,75
14	15	127,3	114,15	21108014	0,98
15	15	135,3	122,17	21108015	1,10
16	19	143,3	130,20	21108016	1,35
17	19	151,4	138,22	21108017	1,49
18	19	159,4	146,28	21108018	1,90
19	19	167,4	154,33	21108019	2,00
20	19	175,5	162,38	21108020	2,25
21	20	183,5	170,43	21108021	2,60
22	20	191,6	178,48	21108022	2,90
23	20	199,7	186,53	21108023	3,10
24	20	207,7	194,59	21108024	3,30
25	20	215,8	202,66	21108025	3,50
26	20	223,8	210,72	21108026	3,70
27	20	231,9	218,79	21108027	3,93
28	20	240,0	226,85	21108028	4,20
29					
30	20	256,1	243,00	21108030	4,60
31					
32	25	272,26	259,13	21108032	5,50
34					
35	25	296,48	283,36	21108035	7,00
38	25	320,70	307,59	21108038	8,00
39	25	327,2	315,6	21108039	8,70
41					
45	25	377,24	364,12	21108045	12,00
48					
50	25	417,64	404,52	21108050	14,00
54					
57	25	474,20	461,08	21108057	22,00
72					
76	25	627,80	614,64	21108076	30,00
80	30	660,7	646,96	21108080	34,00
90					

DUPLEX

Z	D ₁	d _e	d _p	P. NUMBER	kg.
9					
10					
11					
12					
13	20	119,26	106,12	21208013	2,00
14	20	127,27	114,15	21208014	2,59
15	20	135,29	122,17	21208015	3,50
16					
17					
18					
19					
20					
21					
22					
23					
24					
25	25	215,78	202,66	21208025	9,20
26					
27					
28					
29					
30	25	256,12	243,00	21208030	13,85
31					
32	25	272,26	259,13	21208032	15,80
34	25	286,9	275,28	21208034	17,00
35					
38	25	320,70	307,59	21208038	22,77
39					
41					
45	25	377,24	364,12	21208045	32,50
48	25	402,1	388,36	21208048	38,00
50					
54					
57	25	474,20	461,08	21208057	52,75
72					
76	25	627,80	614,64	21208076	90,00
80					
90	30	741,6	727,81	21208090	135,00

TRIPLEX

Z	D ₁	d _e	d _p	P. NUMBER	kg.
9					
10					
11					
12					
13					
14					
15	25	135,3	122,17	21308015	4,90
16					
17					
18					
19					
20					
21					
22					
23					
24					
25	30	215,8	202,66	21308025	15,20
26	30	223,8	210,72	21308026	16,00
27	30	231,9	218,79	21308027	18,00
28					
29					
30	30	256,1	243,00	21308030	27,63
31					
32					
34					
35					
38	30	320,70	307,59	21308038	37,70
39					
40	30	335,3	323,73	21308040	41,80
45	30	377,24	364,12	21308045	53,63
48					
50					
54					
57	40	474,20	461,08	21308057	80,00
72					
76	40	627,80	614,64	21308076	160,00
80					
90					

MATERIAL **FE / C45**

Ask for specific needs.

CAD drawings available on our site
www.chiaravalli.com

Quantity, availability and prices
 on B2B Chiaravalli





pitch 1" 1/4 x 3/4"

PLATEWHEEL

Tooth radius r_3	33,5	mm
Radius width \bar{C}	4	mm
Plate tooth width B_1	18,0	mm
Plate tooth width b_1	17,7	mm
Plate tooth width B_2	53,5	mm
Plate tooth width B_3	89,2	mm

CHAIN

Pitch	31,75	mm
Inner width	19,05	mm
Roller \varnothing	19,05	mm

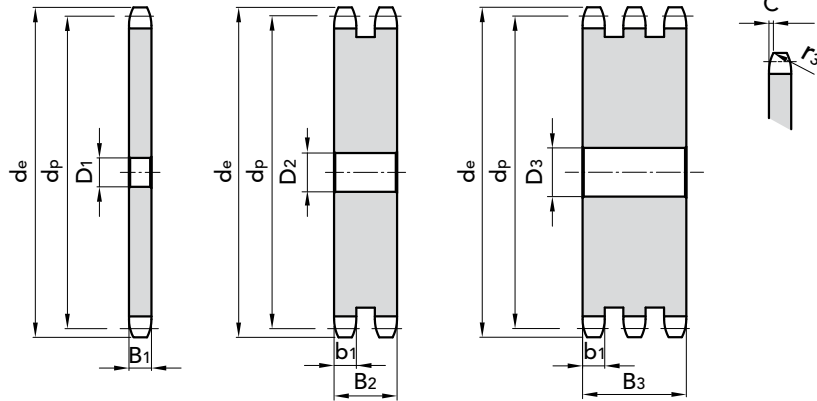

SIMPLEX					
Z	D ₁	d _e	d _p	P. NUMBER	kg.
8	16	98,10	82,96		
9	16	108,0	92,84		
10	16	117,9	102,74	21110010	1,29
11	16	127,8	112,68		
12	20	137,8	122,68	21110012	2,00
13	20	147,8	132,65		
14	20	157,8	142,68		
15	20	167,9	152,72	21110015	2,30
16	25	177,9	162,75		
17	25	187,9	172,78		
18	25	198,0	182,85		
19	25	208,1	192,91		
20	25	218,1	202,95	21110020	4,50
21	25	228,2	213,04		
22	25	238,3	223,11	21110022	4,76
23	25	248,3	233,17		
24	25	258,4	243,23	21110024	5,61
25	25	268,5	253,33	21110025	6,05
26	25	278,6	263,40		
27	25	289,6	273,40		
28	25	299,7	283,56	21110028	7,00
29	25	309,8	293,65		
30	25	319,9	303,75	21110030	9,45
31					
32	25	340,1	323,91	21110032	10,25
33					
34					
35	25	370,4	354,20	21110035	16,00
36					
37					
38	25	400,6	384,49	21110038	18,00
39					
40					
42					
45	30	471,3	455,17	21110045	21,45
50					
57	30	592,5	576,36	21110057	25,00

DUPLEX					
Z	D ₁	d _e	d _p	P. NUMBER	kg.
8					
9					
10					
11					
12					
13					
14					
15					
16					
17					
18					
19					
20					
21					
22					
23					
24	25	258,40	243,23	21210024	16,50
25	25	268,50	253,33	21210025	18,00
26					
27					
28					
29					
30	25	319,9	303,75	21210030	27,00
31					
32					
33					
34					
35					
36					
37					
38	30	400,6	384,49	21210038	35,00
39					
40					
42	30	440,8	424,88	21210042	45,00
45	30	471,3	455,17	21210045	62,15
50					
57	30	592,5	576,36	21210057	102,00

TRIPLEX					
Z	D ₁	d _e	d _p	P. NUMBER	kg.
8					
9					
10					
11					
12	20	137,8	122,68	21310012	5,65
13					
14	30	157,8	142,68	21310014	8,00
15	25	167,9	152,72	21310015	9,61
16					
17					
18					
19	25	208,1	192,91	21310019	16,08
20					
21					
22					
23					
24					
25	25	268,5	253,33	21310025	20,00
26					
27					
28					
29					
30	25	319,9	303,75	21310030	43,96
31					
32					
33					
34					
35					
36					
37					
38					
39					
40	30	420,8	404,68	21310040	65,00
42					
45					
50					
57					

MATERIAL FE / C45

Ask for specific needs.

CAD drawings available on our site
www.chiaravalli.com

Quantity, availability and prices
 on B2B Chiaravalli



PLATEWHEELS ASA 100 pitch 1" 1/4 x 3/4" for roller chains in compliance with DIN 8188 - ISO/R 606 - ANSI B 29.1



PLATEWHEELS ASA 120 pitch 1" 1/2 x 1" for roller chains in compliance with DIN 8188 - ISO/R 606 - ANSI B 29.1

pitch 1" 1/2 x 1"

PLATEWHEEL

Tooth radius r_3	40,5	mm
Radius width C	4,8	mm
Plate tooth width B_1	24,1	mm
Plate tooth width b_1	23,6	mm
Plate tooth width B_2	69,0	mm

CHAIN

Pitch	38,1	mm
Inner width	25,4	mm
Roller \varnothing	22,22	mm

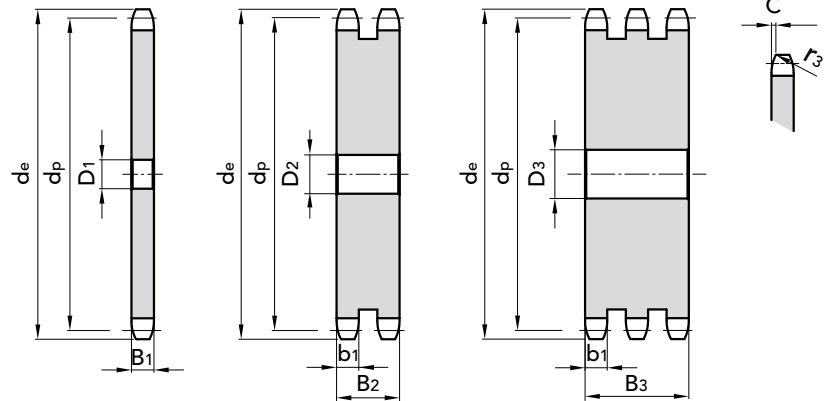

SIMPLEX

Z D₁ d_e d_p P. NUMBER kg.

8					
9					
10					
11					
13					
14					
16	25	214,77	195,29	21112016	4,70
17	25	226,83	207,35	21112017	5,30
18	25	238,89	219,41	21112018	6,00
19					
20	25	263,03	243,55	21112020	7,70
21					
22					
23					
24					
25	25	323,47	303,99	21112025	12,02
30	30	383,97	364,49	21112030	17,50
32	30	408,19	388,71	21112032	20,60
35					
38	30	480,85	461,37	21112038	28,00
41	30	513,5	497,74	21112041	33,85
42					
45	30	565,67	546,19	21112045	42,00
54	30	671	655,25	21112054	72,00
57					
76	40	931	921,98	21112076	120,00

DUPLEX

Z D₁ d_e d_p P. NUMBER kg.

8					
9					
10	25	142,77	123,29	21212010	6,00
11					
13					
14	25	190,7	171,22	21212014	8,00
16					
17	25	226,83	207,35	21212017	14,37
18	25	238,89	219,41	21212018	16,30
19					
20	25	263,03	243,55	21212020	20,00
21	25	270,6	255,65	21212021	23,75
22					
23	25	294,8	279,8	21212023	29,03
24	25	306,8	291,88	21212024	32,90
25	25	323,47	303,99	21212025	33,50
30	30	383,97	364,49	21212030	49,10
32					
35					
38	30	480,85	461,37	21212038	81,45
41					
42					
45	40	565,67	546,19	21212045	115,00
54					
57	40	711,1	691,62	21212057	188,90
76					

CAD drawing available on our site
www.chiaravalli.com

MATERIAL **FE / C45**
 Ask for specific needs.

All eliminated teeth are available
 subject to availability.

On demand we can manufacture ASA
 sprockets and pitches not shown on this
 catalogue.

Quantity, availability and prices
 on B2B Chiaravalli





MATERIAL **C45 UNI 7845**

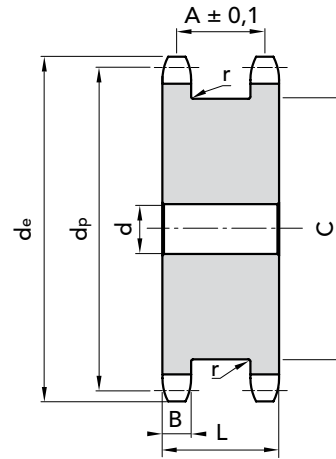

PICH	Z	P. NUMBER	de	dp	d	A	B h14	C max	L	r	Kg
3/8" x 7/32" R. 6.35 06 B-1	13	23209013	43,45	39,8	10	20,3	5,3	28	25,5	0,4	0,14
	15	23209015	49,46	45,81	10	20,3	5,3	34	25,5	0,4	0,20
	17	23209017	55,49	51,84	12	20,3	5,3	40	25,5	0,4	0,26
	18	23209018	58,50	54,85	12	20,3	5,3	43	25,5	0,4	0,30
	19	23209019	61,52	57,87	12	20,3	5,3	46	25,5	0,4	0,34
	20	23209020	54,3	60,89	12	20,3	5,3	49	25,5	0,4	0,38
	21	23209021	67,56	63,91	15	20,3	5,3	52	25,5	0,4	0,43
	23	23209023	73,6	69,95	15	20,3	5,3	59	25,5	0,4	0,54
25	23209025	79,65	76	15	20,3	5,3	65	25,5	0,4	0,65	
1/2" x 5/16" R. 8.51 08 B-1	13	23212013	57,40	53,06	12	24,8	7,2	37	32	0,6	0,27
	15	23212015	65,57	61,08	12	24,8	7,2	45	32	0,6	0,47
	17	23212017	73,61	69,11	12	24,8	7,2	53	32	0,6	0,64
	18	23212018	77,8	73,14	12	24,8	7,2	57	32	0,6	0,73
	19	23212019	81,65	77,16	12	24,8	7,2	62	32	0,6	0,84
	20	23212020	85,8	81,19	12	24,8	7,2	65	32	0,6	0,93
	21	23212021	89,7	85,21	15	24,8	7,2	70	32	0,6	1,03
	23	23212023	98,02	93,27	15	24,8	7,2	78	32	0,6	1,28
25	23212025	105,82	101,33	15	24,8	7,2	86	32	0,6	1,54	
5/8" x 3/8" R. 10.16 10 B-1	13	23215013	73,17	66,33	15	27,9	9,1	48	37	0,6	0,62
	15	23215015	83,19	76,35	15	27,9	9,1	58	37	0,6	0,87
	17	23215017	93,23	86,39	15	27,9	9,1	68	37	0,6	1,17
	18	23215018	93,26	91,42	15	27,9	9,1	72	37	0,6	1,34
	19	23215019	103,29	96,45	15	27,9	9,1	79	37	0,6	1,49
	20	23215020	108,4	101,49	19	27,9	9,1	82	37	0,6	1,68
	21	23215021	113,35	106,51	19	27,9	9,1	89	37	0,6	1,88
	23	23215023	123,43	116,59	19	27,9	9,1	99	37	0,6	2,3
	25	23215025	133,5	126,66	19	27,9	9,1	109	37	0,6	2,77

MATERIAL **C45 UNI 7845**





MATERIAL **C45 UNI 7845**

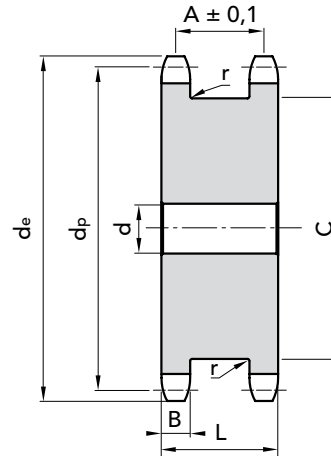

PICH	Z	P. NUMBER	de	dp	d	A	B h14	C max	L	r	Kg
3/4" x 7/16" R. 12.07 12 B-1	13	23219013	87,13	76,9	20	33,9	11,1	59	45	0,6	0,91
	15	23219015	99,16	91,63	20	33,9	11,1	71	45	0,6	1,30
	17	23219017	111,2	103,67	20	33,9	11,1	83	45	0,6	2,12
	18	23219018	117,23	109,71	20	33,9	11,1	88	45	0,6	2,42
	19	23219019	123,27	115,74	20	33,9	11,1	95	45	0,6	2,75
	20	23219020	129,31	121,78	20	33,9	11,1	101	45	0,6	3,09
	21	23219021	135,35	127,82	20	33,9	11,1	107	45	0,6	3,42
	23	23219023	147,43	139,9	20	33,9	11,1	119	45	0,6	4,21
25	23219025	159,52	151,99	24	33,9	11,1	131	45	0,6	5,07	
1" x 17.02 R. 15.88 16 B-1	13	23225013	117,26	106,14	24	47,8	16,2	78	64	0,8	3,14
	15	23225015	133,29	122,17	24	47,8	16,2	95	64	0,8	4,44
	17	23225017	149,35	138,23	24	47,8	16,2	111	64	0,8	5,09
	18	23225018	157,39	146,28	24	47,8	16,2	119	64	0,8	5,90
	19	23225019	165,44	154,32	24	47,8	16,2	127	64	0,8	6,70
	20	23225020	173,49	162,38	24	47,8	16,2	135	64	0,8	7,53
	21	23225021	181,54	170,42	24	47,8	16,2	143	64	0,8	9,48
	23	23225023	197,66	186,54	24	47,8	16,2	160	64	0,8	10,0
	25	23225025	213,78	202,66	24	47,8	16,2	176	64	0,8	11,0

MATERIAL **C45 UNI 7845**

CAD drawings available on our site
www.chiaravalli.com

Quantity, availability and prices
 on B2B Chiaravalli





TAPER LOCK® WITHOUT TAPER BUSH

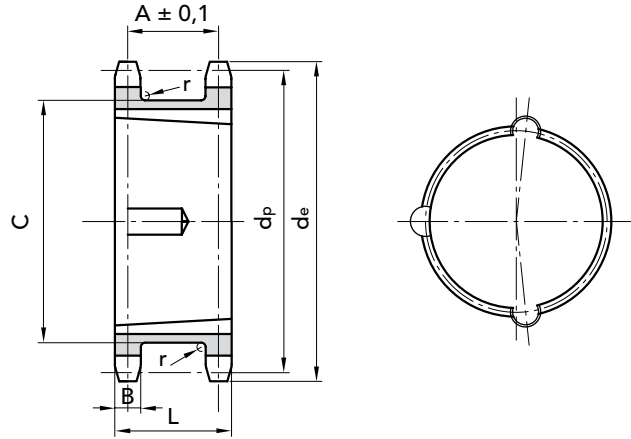

DUPLEX PLATEWHEELS FOR TWO SIMPLEX CHAIN TAPER LOCK®

2

PICH	Z	P. NUMBER	bush	de	dp	A	B h14	C max	L	r	Kg
1/2" x 5/16" R. 8.51 08 B-1	15	27212015	1008	65,57	61,08	24,8	7,2	45	32	0,6	0,47
	17	27212017	1210	73,61	69,12	24,8	7,2	53	32	0,6	0,64
	18	27212018	1210	78	73,14	24,8	7,2	57	32	0,6	0,73
	19	27212019	1210	81,65	77,16	24,8	7,2	62	32	0,6	0,84
	20	27212020	1610	86	81,19	24,8	7,2	65	32	0,6	0,93
	21	27212021	1610	89,7	85,21	24,8	7,2	70	32	0,6	1,03
	23	27212023	1610	97,76	93,27	24,8	7,2	78	32	0,6	1,28
	25	27212025	2012	105,82	101,33	24,8	7,2	86	32	0,6	1,54
30	27212030	2012	125,99	121,5	24,8	7,2	106	32	0,6	1,96	
5/8" x 3/8R. 10.16 10 B-1	15	27215015	1210	83,19	76,35	27,9	9,1	58	37	0,6	0,87
	17	27215017	1610	93,23	86,39	27,9	9,1	68	37	0,6	1,17
	18	27215018	1610	98,3	91,42	27,9	9,1	72	37	0,6	1,34
	19	27215019	1610	103,29	96,45	27,9	9,1	79	37	0,6	1,49
	20	27215020	1610	108,4	101,49	27,9	9,1	82	37	0,6	1,68
	21	27215021	1610	113,35	106,51	27,9	9,1	89	37	0,6	1,88
	23	27215023	1610	123,43	116,59	27,9	9,1	99	37	0,6	2,30
	25	27215025	2012	133,5	126,66	27,9	9,1	109	37	0,6	2,77
	30	27215030	2012	158,71	151,87	27,9	9,1	135	37	0,6	3,20

MATERIAL C45 UNI 7845

CAD drawings available on our site
www.chiaravalli.com

Quantity, availability and prices
on B2B Chiaravalli





TAPER LOCK® WITHOUT TAPER BUSH

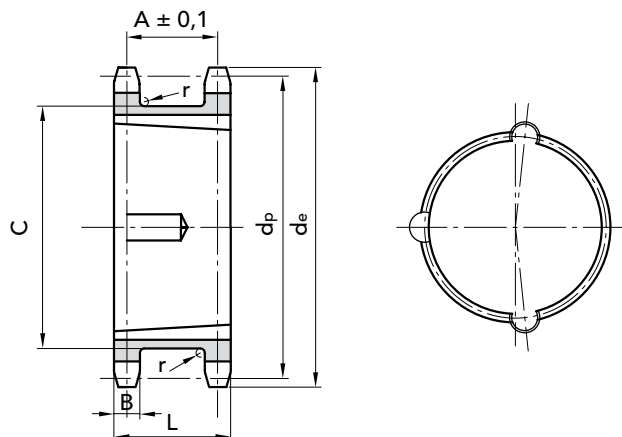

PICH	Z	P. NUMBER	bush	de	dp	A	B h14	C max	L	r	Kg
3/4" x 7/16" R. 12.07 12 B-1	15	27219015	1610	99,16	91,63	33,9	11,1	71	45	0,6	1,33
	17	27219017	1610	111,2	103,67	33,9	11,1	83	45	0,6	2,12
	18	27219018	2012	118	109,71	33,9	11,1	88	45	0,6	2,42
	19	27219019	2012	123,27	115,74	33,9	11,1	95	45	0,6	2,75
	20	27219020	2517	129,7	121,78	33,9	11,1	101	45	0,6	3,09
	21	27219021	2517	135,35	127,82	33,9	11,1	107	45	0,6	3,42
	23	27219023	2517	147,43	139,9	33,9	11,1	119	45	0,6	4,21
	25	27219025	2517	159,52	151,99	33,9	11,1	131	45	0,6	5,07
30	27219030	2517	189,8	182,25	33,9	11,1	162	45	0,6	6,5	
1" x 17.02 R. 15.88 16 B-1	15	27225015	2012	133,29	122,17	47,8	16,2	95	64	0,8	4,44
	17	27225017	2517	149,35	138,23	47,8	16,2	111	64	0,8	5,09
	18	27225018	2517	157,39	146,28	47,8	16,2	119	64	0,8	5,90
	19	27225019	2517	165,44	154,32	47,8	16,2	127	64	0,8	6,70
	20	27225020	2517	173,49	162,38	47,8	16,2	135	64	0,8	7,53
	21	27225021	3020	181,54	170,42	47,8	16,2	143	64	0,8	9,48
	23	27225023	3020	197,66	186,54	47,8	16,2	160	64	0,8	10,0
	25	27225025	3020	213,78	202,66	47,8	16,2	176	64	0,8	11,0
30	27225030	3020	254,10	243	47,8	16,2	216	64	0,8	13,0	

MATERIAL **C45 UNI 7845**

CAD drawings available on our site
www.chiaravalli.com

Quantity, availability and prices
on B2B Chiaravalli





PLATEWHEELS P50 R 25 - 31

CHAIN

Pitch	50	mm
Inner width	11,5	mm
Roller Ø	25	mm
Plate thickness B_1	10,5	mm

CHAIN

Pitch	50	mm
Inner width	15	mm
Roller Ø	31	mm
Plate thickness B_1	13,8	mm

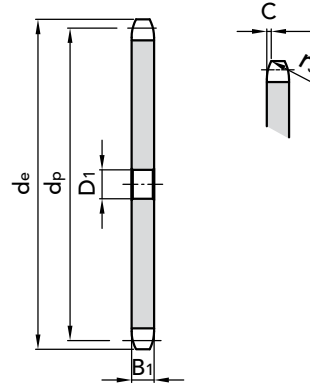

ROLLER 25

Z	D ₁	P. NUMBER	d _e	d _p	kg.
6	20	24502506	115	100	0,55
7	20	24502507	132,7	115,24	0,76
8	20	24502508	148,1	130,6	0,92
9	20	24502509	163,7	146,2	1,30
10	25	24502510	179,3	161,85	1,45
11	25	24502511	195	177,5	1,94
12	25	24502512	211	193,2	2,01
13	30	24502513	226,4	208,95	2,33
14	30	24502514	242,2	224,7	3,06
15	30	24502515	257,9	240,45	3,80
16	30	24502516	273,8	256,3	4,00
17	30	24502517	289,5	272,05	4,20
18	30	24502518	305,4	287,95	5,10
19	30	24502519	321,3	303,8	6,00
20	30	24502520	337,1	319,6	6,45
21	30	24502521	352,9	335,45	6,89
22					
23					
24	30	24502524	400	383,05	9,07
25	30	24502525	416,4	398,95	9,97
26	30	24502526	432,3	414,8	12,06
27	30	24502527	448,2	430,7	12,88
28	30	24502528	464	446,55	13,83
30	30	24502530	495,8	478,35	14,32
32					
35					
38	30	24502538	622,9	605,45	21,50

ROLLER 31

Z	D ₁	P. NUMBER	d _e	d _p	kg.
6	20	24503106	116,2	100,00	0,75
7	20	24503107	133,8	115,24	1,00
8	20	24503108	152,3	130,60	1,10
9	20	24503109	167,9	146,20	1,71
10	25	24503110	183,5	161,85	2,02
11	25	24503111	199,2	177,50	2,31
12	25	24503112	212,0	193,20	2,50
13	30	24503113	230,6	208,95	2,98
14	30	24503114	246,4	224,70	4,05
15	30	24503115	262,1	240,45	4,90
16	30	24503116	278,0	256,30	5,04
17					
18	30	24503118	309,6	287,95	6,90
19	30	24503119	325,5	303,80	6,85
20	30	24503120	341,3	319,60	8,06
21	30	24503121	357,1	335,45	8,80
22	30	24503122	373,0	351,35	9,90
23	30	24503123	388,9	367,20	10,06
24	30	24503124	404,7	383,05	11,25
25	30	24503125	419,7	398,95	12,30
26	30	24503126	436,5	414,80	14,11
27	30	24503127	452,4	430,70	15,46
28	30	24503128	468,2	446,55	16,80
30					
32	30	24503132	531,8	510,10	21,35
35	30	24503135	579,5	557,80	25,7
38	30	24503138	622,0	605,45	30,05

MATERIAL **FE / C45**

Ask for specific needs.

CAD drawings available on our site
www.chiaravalli.com

Quantity, availability and prices
 on B2B Chiaravalli



PLATEWHEELS P75 R 25
CHAIN

Pitch	75	mm
Inner width	15	mm
Roller Ø	25	mm
Plate thickness B ₁	13,8	mm

PLATEWHEELS P75 R 31
CHAIN

Pitch	75	mm
Inner width	15	mm
Roller Ø	31	mm
Plate thickness B ₁	13,8	mm

ROLLER 25

Z	D ₁	P. NUMBER	d _e	d _p	kg.
8	30	24752508	213,4	195,98	3,20
9	30	24752509	236,8	219,3	4,00
10	30	24752510	260,2	242,77	5,00
11	30	24752511	283,7	266,25	5,43
12	30	24752512	307,3	289,8	7,00
13	30	24752513	330,9	313,42	7,56
14					
15	30	24752515	378,1	360,67	8,00
16	30	24752516	401,9	384,45	12,17
17					
20					
21					
25	30	24752525	615,9	598,42	29,25

ROLLER 31

Z	D ₁	P. NUMBER	d _e	d _p	kg.
8	30	24753108	217,6	195,98	3,50
9	30	24753109	241	219,3	3,80
10	30	24753110	264,4	242,77	4,50
11	30	24753111	287,9	266,25	5,57
12	30	24753112	311,5	289,8	6,70
13	30	24753113	334,1	313,42	7,80
14	30	24753114	358,7	337,05	9,12
15	30	24753115	382,3	360,67	10,42
16	30	24753116	406,1	384,45	11,98
17					
20					
21	30	24753121	524,8	503,17	20,62
25	30	24753125	620,1	598,42	27,00

PLATEWHEELS P100 R 31
CHAIN

Pitch	100	mm
Inner width	15	mm
Roller Ø	31	mm
Plate thickness B ₁	13,8	mm

PLATEWHEELS P100 R 40
CHAIN

Pitch	100	mm
Inner width	22	mm
Roller Ø	40	mm
Plate thickness B ₁	20	mm

ROLLER 31

Z	D ₁	P. NUMBER	d _e	d _p	kg.
8	30	24993108	282,9	261,31	4,92
9	30	24993109	314,1	292,4	6,03
10	30	24993110	345,4	323,61	8,00
11	30	24993111	376,7	354,95	9,04
12	30	24993112	408,1	386,4	10,75
13	30	24993113	439,6	417,9	16,00
14	30	24993114	471,1	449,4	17,00
15	30	24993115	502,6	480,9	19,00
16	30	24993116	534,3	512,6	21,80
17	30	24993117	565,8	544,1	24,77
18	30	24993118	597,6	575,9	26,43
19					
20					

ROLLER 40

Z	D ₁	P. NUMBER	d _e	d _p	kg.
8	30	24994008	282,9	261,31	7,14
9	30	24994009	314,1	292,4	10,03
10	30	24994010	345,4	323,61	11,95
11	30	24994011	376,7	354,95	15,02
12	30	24994012	408,1	386,4	17,27
13					
14	30	24994014	471,1	449,4	24,60
15					
16	30	24994016	534,3	512,6	27,99
17					
18					
19					
20	30	24994020	663	639,2	42,62

MATERIAL **FE / C45**

Ask for specific needs.

CAD drawings available on our site
www.chiaravalli.com

Quantity, availability and prices
 on B2B Chiaravalli





WHEELS FOR TABLE TOP CHAINS

WHEELS
FOR TABLE TOP CHAINS

page 47





WHEELS FOR TABLE TOP CHAINS





HUBS and ADAPTORS

WELDED HUBS	page 51
WELDED HUBS FOR TAPER BUSHES	52
REMOUVABLE HUBS FOR TAPER BUSHES	53
REMOUVABLE HUBS FOR PLATEWHEELS	54
ADAPTORS FOR TAPER BUSHES	55

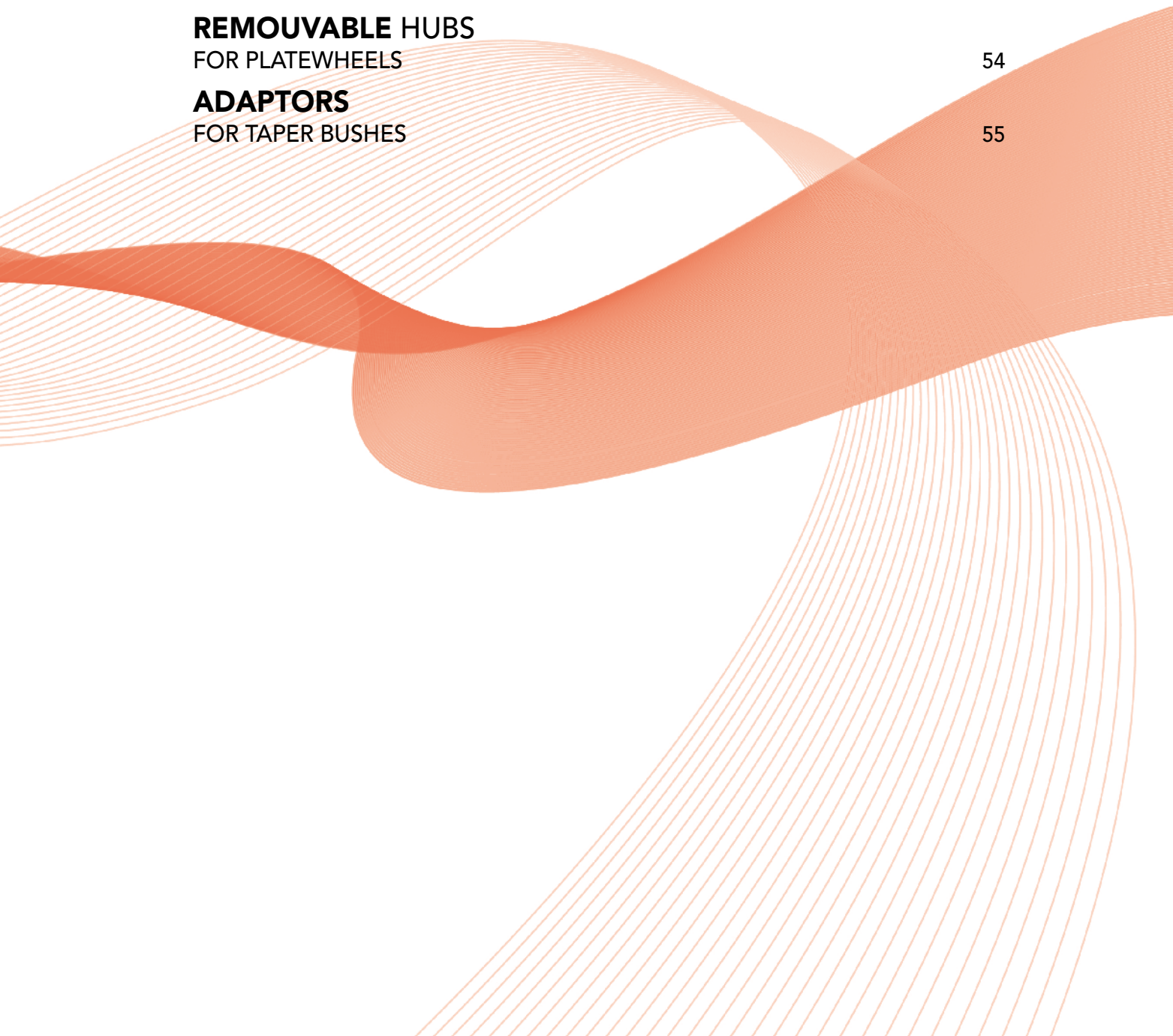

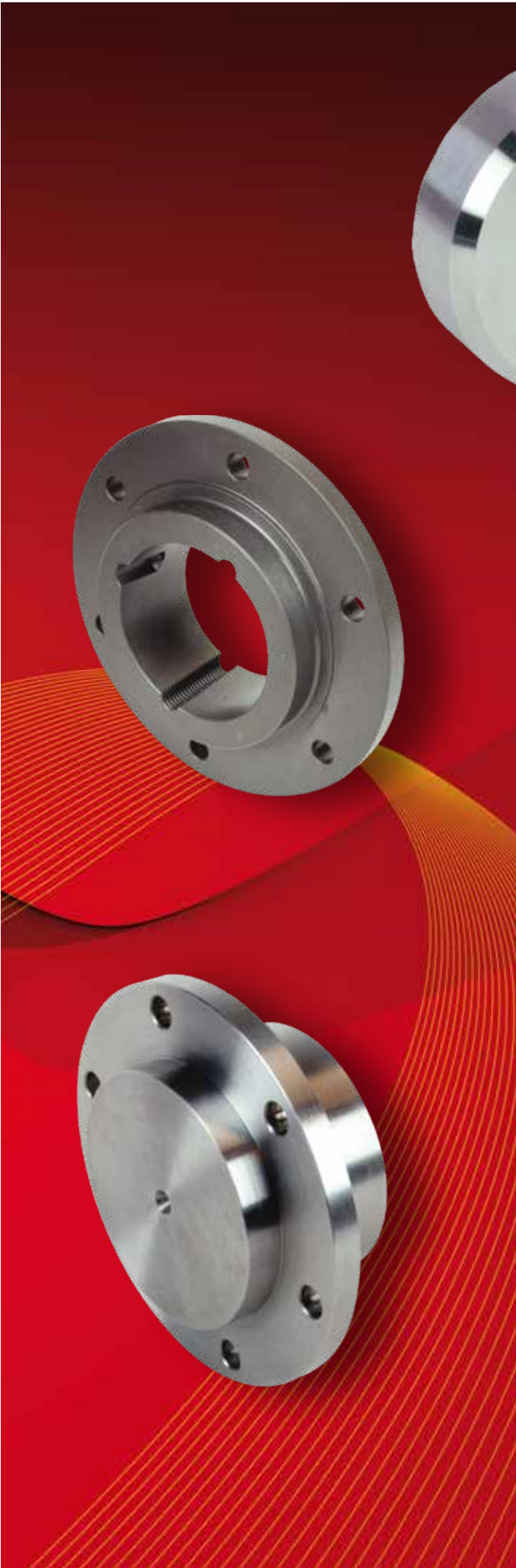

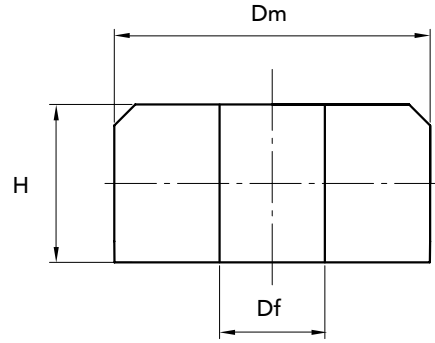

Dm	H	Df	PART NUMBER	WEIGHT Kg.	Dm	H	Df	PART NUMBER	WEIGHT Kg.	Dm	H	Df	PART NUMBER	WEIGHT Kg.	Dm	H	Df	PART NUMBER	WEIGHT Kg.
60	30	20	00001105	0,59	130	20	25	00001380	2,37	150	33	25	00001750	4,45	180	28	40	00002090	5,35
80	27	16	00001110	1,02	130	25	20	00001400	2,55	150	33	30	00001760	4,38	180	31	40	00002100	5,87
80	27	20	00001120	1,00	130	25	25	00001410	2,50	150	36,5	25	00001770	4,94	180	34	30	00002130	6,67
90	26	16	00001130	1,26	130	32	25	00001440	3,21	150	52	30	00001780	6,90	180	46	30	00002150	8,92
90	26	20	00001140	1,23	130	38	25	00001460	3,81	150	62	30	00001790	8,29	180	61	30	00002160	11,18
90	31	16	00001150	1,49	133	34	30	00001490	3,52	150	72	30	00001800	9,59	180	71	40	00002170	13,50
90	31	20	00001160	1,46	133	50,6	30	00001500	5,23	155	34	30	00001820	4,81	200	30	40	00002180	5,70
90	33	20	00001170	1,56	135	32	25	00001510	3,47	155	50,6	30	00001830	7,20	200	32	30	00002190	7,71
90	33	25	00001180	1,52	135	40,6	25	00001530	4,40	160	21	30	00001840	3,22	200	32	40	00002200	7,58
100	31	20	00001190	1,82	140	21	25	00001540	2,45	160	28	25	00001850	4,30	200	34	30	00002230	8,18
100	31	25	00001200	1,78	140	21	30	00001550	2,42	160	28	30	00001860	4,22	200	34	40	00002240	8,00
100	41	25	00001210	2,37	140	24	25	00001570	2,87	160	32	30	00001900	4,98	200	38	40	00002250	8,99
110	25	25	00001220	1,76	140	28	25	00001740	3,27	160	36	30	00001930	5,50	200	49	40	00002260	11,6
110	29	20	00001230	2,08	140	33	25	00001600	3,86	160	46	30	00001970	7,04	200	71	40	00002270	16,80
110	29	25	00001240	2,05	140	33	30	00001610	3,83	160	50,6	30	00001980	7,70	200	81	40	00002280	19,17
110	35	25	00001250	2,46	140	64	30	00001620	7,30	160	60,6	30	00001990	9,45	220	32	30	00002300	9,37
110	45	25	00001260	3,16	145	32	25	00001630	4,07	160	66	30	00002000	10,06	220	32	40	00002310	9,21
110	45	30	00001270	3,10	145	32	30	00001640	3,90	160	76	30	00002010	11,50	220	33	40	00002320	9,52
120	19,5	20	00001300	2,19	145	34	30	00001660	4,21	160	76	40	00002020	11,24	220	42	40	00002330	12,12
120	25,4	25	00001320	2,16	145	40,6	25	00001670	5,11	170	28	30	00002030	4,82	220	48	40	00002340	13,85
120	34	25	00001330	2,89	145	50,6	30	00001680	6,30	170	45,6	30	00002050	7,96	250	30	40	00002350	8,66
125	54	25	00001340	5,02	150	24	25	00001690	3,23	170	60,6	30	00002060	10,44	250	34	40	00002360	9,81
125	54	30	00001350	4,95	150	24	30	00001700	3,19	170	76	40	00002070	12,79	250	42	40	00002370	12,11
130	20	20	00001370	2,00	150	29,7	25	00001730	4,00	180	19	40	00002080	3,60	250	44	40	00002390	12,70

MATERIAL FE 50



CAD drawings available on our site
www.chiaravalli.com

Quantity, availability and prices
on B2B Chiaravalli

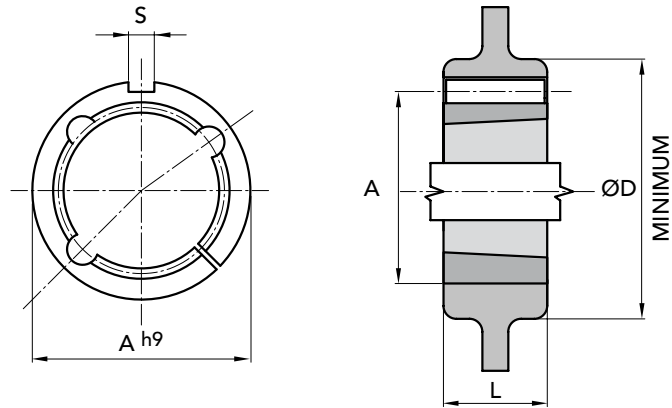

TYPE ADAPTORS	PART NUMBER	N. TAPER BUSHE	L	A h9	Ø D FOR HUBS of PULLEYS and SPROCKETS in CAST IRON and		S DIN 6885	WEIGHT Kg. for C.I.
					STEEL			
ARC 1008	29901008	1008	22	45	75	60	5 x 5	0,45
ARC 1210	29901210	1210	25	60	105	85	6 x 6	0,70
ARC 1610	29901610	1610	25	70	115	95	10 x 8	0,80
ARC 1615	29901615	1615	38	70	115	95	10 x 8	0,90
ARC 2517	29902517	2517	45	105	150	130	16 x 10	2,20
ARC 3030	29903030	3030	76	130	190	160	20 x 12	5,80
ARC 3535	29903535	3535	90	160	240	* 200	22 x 12	11,30
ARC 4040	29904040	4040	102	185	290	* 240	24 x 12	17,30

MATERIAL **GREY CAST IRON**
norm UNI EN 1561

* They differ from the Norma DIN 6885

CAD drawings available on our site
www.chiaravalli.com

Quantity, availability and prices
on B2B Chiaravalli



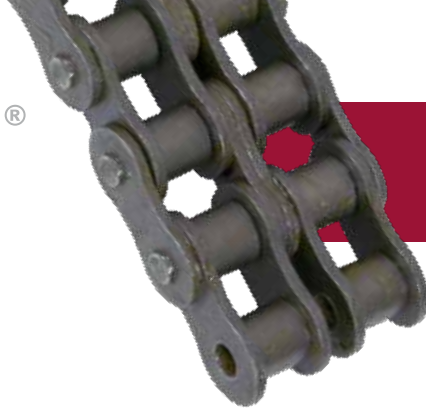

CHAINS

ROLLER CHAINS QRC [®]	3
CHAIN PLATE STRAIGHT QRC [®]	7
CHAINS PINS DRILLED QRC [®]	7
TRANSPORT CHAINS CRT [®]	9

NEW QRC[®]

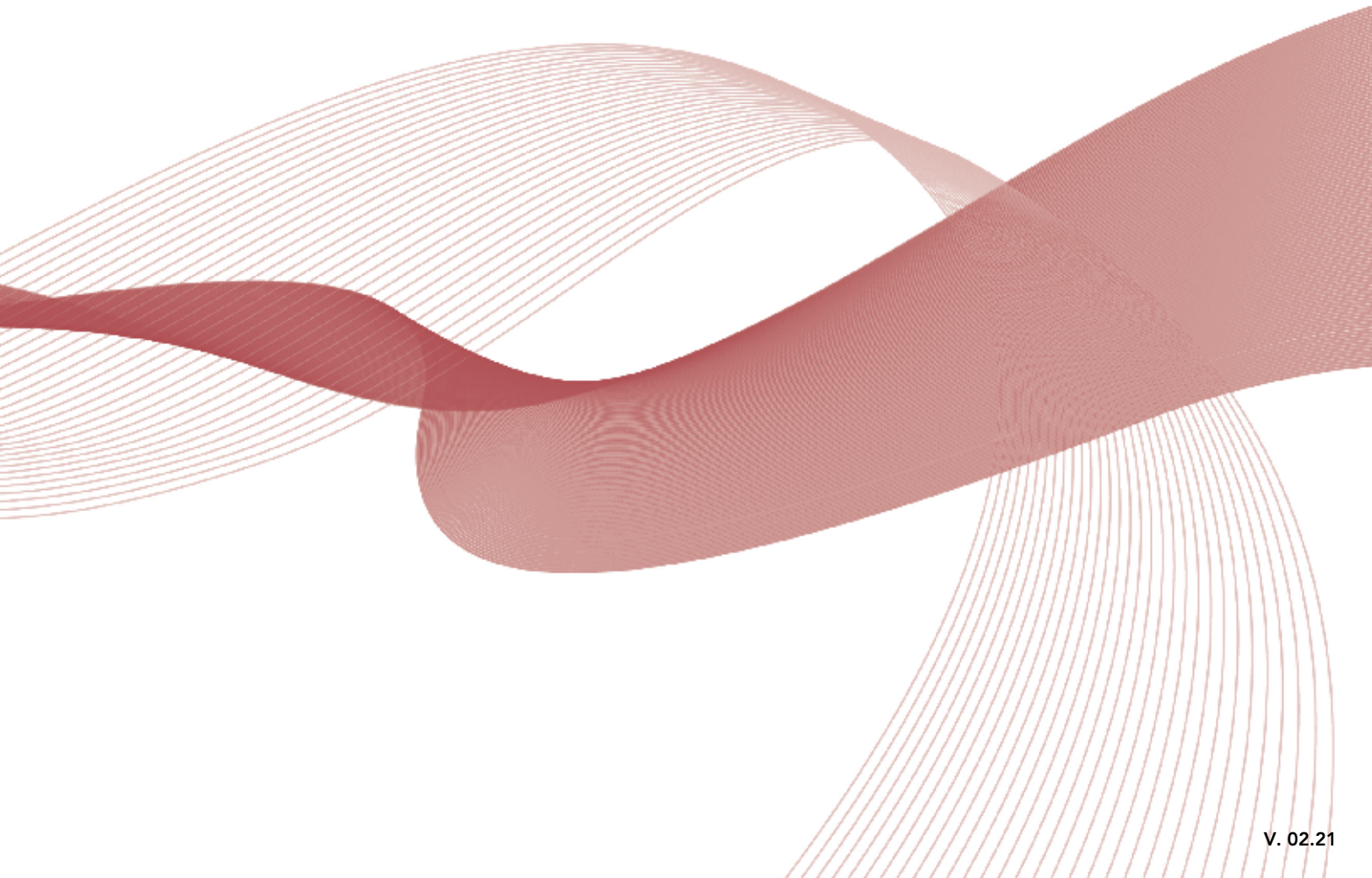



**OFFSET
SIMPLEX**



COUPLING

(*)

SIMPLEX - CLIP



ONLY FOR
ARTICLE
O5 B1

**OFFSET
WITH 3 ROLLERS**



COUPLING

(◆)

SIMPLEX - COTTER PIN



**OFFSET
DUPLEX**



COUPLING

DUPLEX



**OFFSET
TRIPLEX**



COUPLING

TRIPLEX

(*) COUPLINGS with CLIP

(*) COUPLINGS with CLIP part number5057
(◆) and/or COTTER PIN part number5157

(◆) COUPLINGS with COTTER PIN

from 04 (B1, B2, B3)
to 12 (B1, B2, B3)

16 (B1, B2, B3)

from 20 (B1, B2, B3)
to 32 (B1, B2, B3)



CHAINS MANUFACTURED
BY AN **ISO 9001** CERTIFIED
FACTORY

ACCORDING TO
ISO 606 - DIN 8187

Pack of 5m

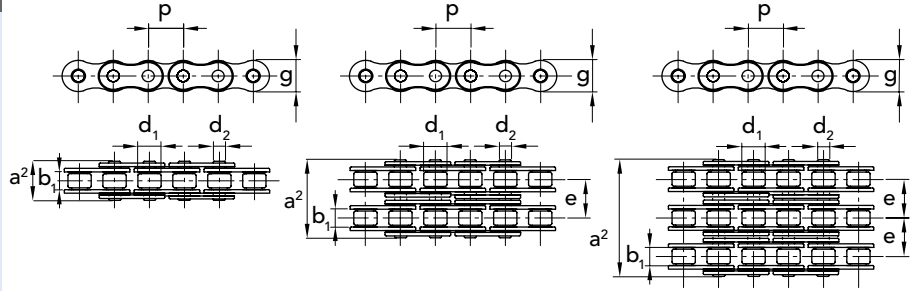

f = resistant surface

ROLLER CHAINS EUROPEAN SERIES QRC®

4

SIMPLEX

ISO N.	COUPLING			OFFSET	P		b ₁	d ₂	d ₁	a ²	g	f	breaking load		kg/m
	PART NUMBER	PART NUMBER	PART NUMBER		mm	inch							min. mm	mm	
04 B-1	70106007	70106057	70106087	6	-	2,80	1,85	4	7,4	5	0,07	3,0	0,12		
05 B-1	70108007	70108057	70108087	8	-	3,00	2,31	5	8,6	7,11	0,11	5,0	0,18		
06 B-1	70109007	70109057	70109087	9,525	3/8"	5,72	3,28	6,35	13,5	8,26	0,28	9,0	0,40		
081-1	70110008	70110058	70110088	12,7	1/2"	3,3	3,64	7,75	9,3	9,8	0,2	8,0	0,28		
083-1	70111008	70111058	70111088	12,7	1/2"	4,88	4,06	7,75	12,9	10,3	0,32	12,0	0,42		
084-1	701171008	701171058	701171088	12,7	1/2"	4,88	4,06	7,75	14,2	11,0	0,35	16,0	0,59		
08 B-1	70112007	70112057	70112087	12,7	1/2"	7,75	4,45	8,51	17	11,81	0,5	18,0	0,68		
10 B-1	70115007	70115057	70115087	15,875	5/8"	9,65	5,08	10,16	19,6	14,73	0,67	22,4	0,91		
12 B-1	70119007	70119057	70119087	19,05	3/4"	11,68	5,72	12,07	22,7	16,13	0,89	29,0	1,12		
16 B-1	70125007	70125057	70125087	25,40	1"	17,02	8,28	15,88	36,1	21,08	2,1	60,0	2,59		
16 B-1 (♦)		70125157	con coppiglia	25,40	1"	17,02	8,28	15,88	36,1	21,08	2,1	60,0	2,59		
20 B-1	70131007	70131057	70131087	31,75	1 1/4"	19,56	10,19	19,05	43,2	26,42	2,95	95,00	3,68		
24 B-1	70138007	70138057	70138087	38,1	1 1/2"	25,40	14,63	25,4	53,4	33,4	5,54	160,0	6,85		
28 B-1	70144007	70144057	70144087	44,45	1 3/4"	30,99	15,9	27,94	65,1	37,08	7,4	200,0	8,56		
32 B-1	70150007	70150057	70150087	50,8	2"	38,10	17,81	29,21	67,4	42,29	8,11	250,0	9,49		

DUPLEX

ISO N.	COUPLING			OFFSET	P		b ₁	d ₂	d ₁	a ²	g	f	breaking load		kg/m
	PART NUMBER	PART NUMBER	PART NUMBER		mm	inch							min. mm	mm	
05 B-2	70208007	70208057	70208087	8	-	3	2,31	5	14,3	7,11	5,64	0,22	9,8	0,36	
06 B-2	70209007	70209057	70209087	9,525	3/8"	5,72	3,28	6,35	23,8	8,26	10,24	0,55	16,9	0,76	
08 B-2	70212007	70212057	70212087	12,7	1/2"	7,75	4,45	8,51	31	11,81	13,92	1	32,0	1,31	
10 B-2	70215007	70215057	70215087	15,875	5/8"	9,65	5,08	10,16	36,2	14,73	16,59	1,34	44,5	1,79	
12 B-2	70219007	70219057	70219087	19,05	3/4"	11,68	5,72	12,07	42,2	16,13	19,46	1,78	57,8	2,22	
16 B-2	70225007	70225057	70225087	25,40	1"	17,02	8,28	15,88	68	21,08	31,88	4,21	106,0	5,03	
16 B-2 (♦)		70225157	with cotter pin	25,40	1"	17,02	8,28	15,88	68	21,08	31,88	4,21	99,6	5,03	
20 B-2	70231007	70231057	70231087	31,75	1 1/4"	19,56	10,19	19,05	79,7	26,42	35,45	5,91	170,0	7,33	
24 B-2	70238007	70238057	70238087	38,1	1 1/2"	25,40	14,63	25,4	101,8	33,4	48,36	11,09	280,0	13,5	
28 B-2	70244007	70244057	70244087	44,45	1 3/4"	30,99	15,9	27,94	124,7	37,08	59,56	14,81	360,0	16,96	
32 B-2	70250007	70250057	70250087	50,8	2"	30,99	17,81	29,21	126	42,29	58,55	16,23	450,0	18,74	

TRIPLEX

ISO N.	COUPLING			OFFSET	P		b ₁	d ₂	d ₁	a ²	g	f	breaking load		kg/m
	PART NUMBER	PART NUMBER	PART NUMBER		mm	inch							min. mm	mm	
06 B-3	70309007	70309057	70309087	9,525	3/8"	5,72	3,28	6,35	34	8,26	10,24	0,83	24,9	1,12	
08 B-3	70312007	70312057	70312087	12,7	1/2"	7,75	4,45	8,51	44,9	11,81	13,92	1,5	47,5	1,94	
10 B-3	70315007	70315057	70315087	15,875	5/8"	9,65	5,08	10,16	52,8	14,73	16,59	2,02	66,7	2,68	
12 B-3	70319007	70319057	70319087	19,05	3/4"	11,68	5,72	12,07	61,7	16,13	19,46	2,68	86,7	3,32	
16 B-3	70325007	70325057	70325087	25,40	1"	17,02	8,28	15,88	99,9	21,08	31,88	6,32	160,0	7,65	
16 B-3 (♦)		70325157	with cotter pin	25,40	1"	17,02	8,28	15,88	99,9	21,08	31,88	6,32	149,4	7,65	
20 B-3	70331007	70331057	70331087	31,75	1 1/4"	19,56	10,19	19,05	116,1	26,42	35,45	8,86	250,0	10,96	
24 B-3	70338007	70338057	70338087	38,1	1 1/2"	25,40	14,63	25,4	150,2	33,4	48,36	16,64	425,0	20,2	
28 B-3	70344007	70344057	70344087	44,45	1 3/4"	30,99	15,9	27,94	184,3	37,08	59,56	22,21	530,0	25,38	
32 B-3	70350007	70350057	70350087	50,8	2"	30,99	17,81	29,21	184,5	42,29	58,55	24,34	670,0	28,04	

Please note: all QRC® chains are subject to pretensioning.
This operation is made in order to fix dimension and stretching.

CAD drawings available on our site
www.chiaravalli.com

Quantity, availability and prices
on B2B Chiaravalli





CHAINS MANUFACTURED
BY AN ISO 9001 CERTIFIED
FACTORY

ACCORDING TO
ISO 606 - DIN 8187

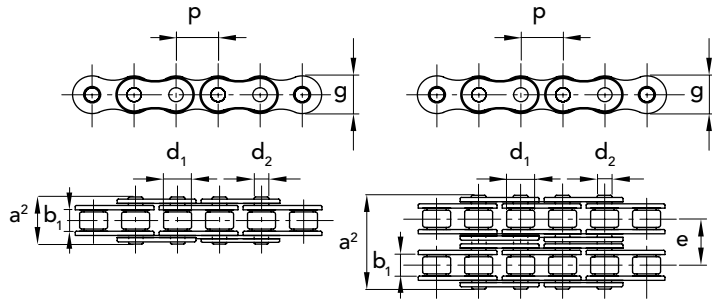

f = resistant surface

SIMPLEX

100 mt in rolls

ISO N.	CHAIN P. NUMBER	COUPLING P. NUMBER	OFFSET P. NUMBER	P	b ₁	d ₂	d ₁	a ²	g	f	breaking load	kg/m
				mm	min. mm	mm	max mm	max mm	max mm	cm ²	N. mm ²	=
05 B-1	72108007	70108057	70108087	8	3,00	2,31	5	8,6	7,11	0,11	5,0	0,18
06 B-1	72109007	70109057	70109087	9,525	3/8"	5,72	3,28	6,35	8,26	0,28	9,0	0,40
081-1	72110008	70110058	70110088	12,7	1/2"	3,3	3,64	7,75	9,8	0,2	8,0	0,28
083-1	72111008	70111058	70111088	12,7	1/2"	4,88	4,06	7,75	10,3	0,32	12,0	0,42
084-1	72171008	70171058	70171088	12,7	1/2"	4,88	4,06	7,75	11,0	0,35	16,0	0,59

50 mt in rolls

ISO N.	CHAIN P. NUMBER	COUPLING P. NUMBER	OFFSET P. NUMBER	P	b ₁	d ₂	d ₁	a ²	g	f	breaking load	kg/m
				mm	min. mm	mm	max mm	max mm	max mm	cm ²	N. mm ²	=
08 B-1	72112007	70112057	70112087	12,7	1/2"	7,75	4,45	8,51	11,81	0,5	18,0	0,68
10 B-1	72115007	70115057	70115087	15,875	5/8"	9,65	5,08	10,16	14,73	0,67	22,4	0,91

25 mt in rolls

ISO N.	CHAIN P. NUMBER	COUPLING P. NUMBER	OFFSET P. NUMBER	P	b ₁	d ₂	d ₁	a ²	g	f	breaking load	kg/m
				mm	min. mm	mm	max mm	max mm	max mm	cm ²	N. mm ²	=
12 B-1	72119007	70119057	70119087	19,05	3/4"	11,68	5,72	12,07	16,13	0,89	29,0	1,12
16 B-1	72125007	70125057	70125087	25,40	1"	17,02	8,28	15,88	21,08	2,1	60,0	2,59
20 B-1	72131007	70131057	70131087	31,75	1 1/4"	19,56	10,19	19,05	26,42	2,95	95,00	3,68

DUPLEX

25 mt in rolls

ISO N.	CHAIN P. NUMBER	COUPLING P. NUMBER	OFFSET P. NUMBER	P	b ₁	d ₂	d ₁	a ²	g	e	f	breaking load	kg/m
				mm	min. mm	mm	max mm	max mm	max mm	mm	cm ²	N. mm ²	=
06 B-2	72209007	70209057	70209087	9,525	3/8"	5,72	3,28	6,35	8,26	10,24	0,55	16,9	0,76
08 B-2	72212007	70212057	70212087	12,7	1/2"	7,75	4,45	8,51	11,81	13,92	1	32,0	1,31
10 B-2	72215007	70215057	70215087	15,875	5/8"	9,65	5,08	10,16	14,73	16,59	1,34	44,5	1,79
12 B-2	72219007	70219057	70219087	19,05	3/4"	11,68	5,72	12,07	16,13	19,46	1,78	57,8	2,22
16 B-2	72225007	70225057	70225087	25,40	1"	17,02	8,28	15,88	21,08	31,88	4,21	106,0	5,03

Please note: all QRC® chains are subject to pretensioning.
This operation is made in order to fix dimension and stretching.

CAD drawings available on our site
www.chiaravalli.com

Quantity, availability and prices
on B2B Chiaravalli





CHAINS MANUFACTURED
BY AN **ISO 9001** CERTIFIED
FACTORY

ACCORDING TO
ISO 606 - DIN 8187

Pack of 5m

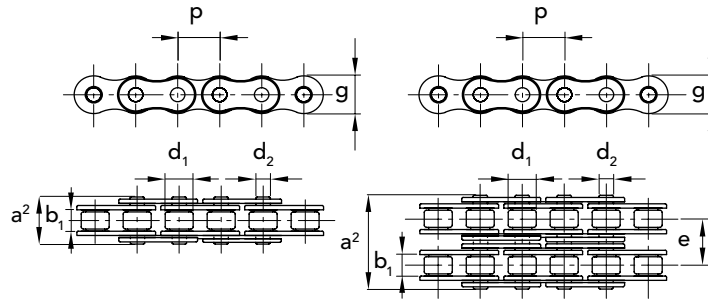

f = resistant surface

SIMPLEX STAINLESS STEEL AISI 304

ISO N.	CHAIN P. NUMBER	COUPLING P. NUMBER	OFFSET P. NUMBER	P	b ₁	d ₂	d ₁	a ²	g	e	f	breaking load N. mm ²	kg/m
				mm inch	min. mm	mm	max mm	max mm	max mm	mm	cm ²		=
05 B-1	74108007	74108057	74108087	8,00 -	3	2,31	5	8,6	7,11	0,11	0,18	5,0	0,18
06 B-1	74109007	74109057	74109087	9,53 3/8"	5,72	3,28	6,35	13,5	8,26	0,28	0,41	6,2	0,40
08 B-1	74112007	74112057	74112087	12,70 1/2"	7,75	4,45	8,51	17	11,81	0,5	0,7	12,0	0,68
10 B-1	74115007	74115057	74115087	15,88 5/8"	9,65	5,08	10,16	19,6	14,73	0,67	0,95	14,5	0,91
12 B-1	74119007	74119057	74119087	19,05 3/4"	11,68	5,72	12,07	22,7	16,13	0,89	1,25	18,5	1,12
16 B-1	74125007	74125057	74125087	25,40 1"	17,02	8,28	15,88	36,1	21,08	2,1	2,7	40,0	2,59

DUPLEX STAINLESS STEEL AISI 304

ISO N.	CHAIN P. NUMBER	COUPLING P. NUMBER	OFFSET P. NUMBER	P	b ₁	d ₂	d ₁	a ²	g	e	f	breaking load N. mm ²	kg/m
				mm inch	min. mm	mm	max mm	max mm	max mm	mm	cm ²		=
06 B-2	74209007	74209057	74209087	9,53 3/8"	5,72	3,28	6,35	23,8	8,26	10,24	0,55	8,4	1,35
08 B-2	74212007	74212057	74212087	12,70 1/2"	7,75	4,45	8,51	31	11,81	13,92	1	16,0	1,85
10 B-2	74215007	74215057	74215087	15,88 5/8"	9,65	5,08	10,16	36,2	14,73	16,59	1,34	22,2	2,20
12 B-2	74219007	74219057	74219087	19,05 3/4"	11,68	5,72	12,07	42,2	16,13	19,46	1,78	28,5	2,50
16 B-2	74225007	74225057	74225087	25,40 1"	17,02	8,28	15,88	68	21,08	31,88	4,21	53	5,40

SIMPLEX NICKEL - PLATED

ISO N.	CHAIN P. NUMBER	COUPLING P. NUMBER	OFFSET P. NUMBER	P	b ₁	d ₂	d ₁	a ²	g	f	breaking load N. mm ²	kg/m
				mm inch	min. mm	mm	max mm	max mm	max mm	cm ²		=
06 B-1	73109007	73109057	73109087	9,53 3/8"	5,72	3,28	6,35	13,5	8,26	0,28	8,2	0,41
08 B-1	73112007	73112057	73112087	12,70 1/2"	7,75	4,45	8,51	17	11,81	0,5	16,4	0,70
10 B-1	73115007	73115057	73115087	15,88 5/8"	9,65	5,08	10,16	19,6	14,73	0,67	20,5	0,95
12 B-1	73119007	73119057	73119087	19,05 3/4"	11,68	5,72	12,07	22,7	16,13	0,89	26,5	1,25
16 B-1	73125007	73125057	73125087	25,40 1"	17,02	8,28	15,88	36,1	21,08	2,1	52,5	2,70
16 B-1 (*)		73125157	with clip	25,40 1"	17,02	8,28	15,88	36,1	21,08	2,1	52,5	2,70

Please note: all QRC® chains are subject to pretensioning. This operation is made in order to fix dimension and stretching.



CAD drawings available on our site
www.chiaravalli.com

Quantity, availability and prices
on B2B Chiaravalli



CHAINS MANUFACTURED BY AN ISO 9001 CERTIFIED FACTORY

ACCORDING TO ISO 606 - DIN 8187

Please note: all QRC® chains are subject to pretensioning. This operation is made in order to fix dimension and stretching.

Pack of 5m

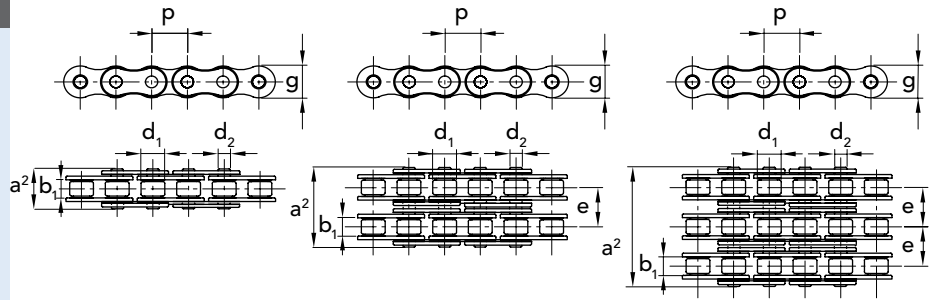

f = resistant surface

SIMPLEX "ANSI" ASA

ANSI N.	CHAIN P. NUMBER	COUPLING P. NUMBER	OFFSET P. NUMBER	P		b ₁ min. mm	d ₂ mm	d ₁ max mm	a ² max mm	g max mm	f cm ²	breaking load KN. min.	kg/m =
				mm	inch								
35-1	71103007	71103057	71103087	9,525	3/8"	4,77	3,58	5,08	13,2	9,05	0,27	7,9	0,34
40-1	71104007	71104057	71104087	12,7	1/2"	7,95	3,96	7,92	17,8	12,07	0,44	14,1	0,63
50-1	71105007	71105057	71105087	15,875	5/8"	9,53	5,08	10,16	21,8	15,09	0,7	22,2	1,04
60-1	71106007	71106057	71106087	19,05	3/4"	12,7	5,94	11,91	26,9	18,08	1,06	31,8	1,52
80-1	71108007	71108057	71108087	25,40	1"	15,88	7,92	15,88	33,5	24,13	1,79	56,7	2,58
100-1	71110007	71110057	71110087	31,75	1 1/4"	19,05	9,53	19,05	41,1	30,18	2,62	88,5	3,85
120-1	71112007	71112057	71112087	38,1	1 1/2"	25,4	11,1	22,23	50,8	36,2	3,94	127,0	5,61
140-1	71114007	71114057	71114087	44,45	1 3/4"	25,4	12,7	25,4	54,9	42,24	4,72	172,4	7,24
160-1	71116007	71116057	71116087	50,8	2"	31,75	14,27	28,58	65,5	48,26	6,5	226,8	9,91

DUPLEX "ANSI" ASA

ANSI N.	CHAIN P. NUMBER	COUPLING P. NUMBER	OFFSET P. NUMBER	P		b ₁ min. mm	d ₂ mm	d ₁ max mm	a ² max mm	g max mm	e mm	f cm ²	breaking load KN. min.	kg/m =
				mm	inch									
35-2	71203007	71203057	71203087	9,525	3/8"	4,77	3,58	5,08	21,6	9,05	10,13	0,54	15,8	0,67
40-2	71204007	71204057	71204087	12,7	1/2"	7,95	3,96	7,92	32,3	12,07	14,38	0,88	28,2	1,26
50-2	71205007	71205057	71205087	15,875	5/8"	9,53	5,08	10,16	39,9	15,09	18,11	1,4	44,4	2,05
60-2	71206007	71206057	71206087	19,05	3/4"	12,7	5,94	11,91	49,8	18,08	22,78	2,12	63,6	3,01
80-2	71208007	71208057	71208087	25,40	1"	15,88	7,92	15,88	62,7	24,13	29,29	3,58	113,4	5,13
100-2	71210007	71210057	71210087	31,75	1 1/4"	19,05	9,53	19,05	77	30,18	35,76	5,24	177,0	7,64
120-2	71212007	71212057	71212087	38,1	1 1/2"	25,4	11,1	22,23	96,3	36,2	45,44	7,88	254,0	11,13
140-2	71214007	71214057	71214087	44,45	1 3/4"	25,4	12,7	25,4	103,6	42,24	48,87	9,44	344,8	14,37
160-2	71216007	71216057	71216087	50,8	2"	31,75	14,27	28,58	124,2	48,26	58,55	13	453,6	19,68

TRIPLEX "ANSI" ASA

ANSI N.	CHAIN P. NUMBER	COUPLING P. NUMBER	OFFSET P. NUMBER	P		b ₁ min. mm	d ₂ mm	d ₁ max mm	a ² max mm	g max mm	e mm	f cm ²	breaking load KN. min.	kg/m =
				mm	inch									
35-3	71303007	71303057	71303087	9,525	3/8"	4,77	3,58	5,08	31,8	9,05	10,13	0,81	23,7	0,99
40-3	71304007	71304057	71304087	12,7	1/2"	7,95	3,96	7,92	46,7	12,07	14,38	1,32	42,3	1,98
50-3	71305007	71305057	71305087	15,875	5/8"	9,53	5,08	10,16	57,9	15,09	18,11	2,1	66,6	3,06
60-3	71306007	71306057	71306087	19,05	3/4"	12,7	5,94	11,91	72,6	18,08	22,78	3,18	95,4	4,50
80-3	71308007	71308057	71308087	25,40	1"	15,88	7,92	15,88	91,7	24,13	29,29	5,37	170,1	7,67
100-3	71310007	71310057	71310087	31,75	1 1/4"	19,05	9,53	19,05	113	30,18	35,76	7,86	265,5	11,43
120-3	71312007	71312057	71312087	38,1	1 1/2"	25,4	11,1	22,23	141,7	36,2	45,44	11,82	381,0	16,67
140-3	71314007	71314057	71314087	44,45	1 3/4"	25,4	12,7	25,4	152,4	42,24	48,87	14,16	517,2	21,51
160-3	71316007	71316057	71316087	50,8	2"	31,75	14,27	28,58	182,9	48,26	58,55	19,5	680,4	29,45

SIMPLEX REINFORCED

ANSI N.	CHAIN P. NUMBER	COUPLING P. NUMBER	OFFSET P. NUMBER	P		b ₁ min. mm	d ₂ mm	d ₁ max mm	a ² max mm	g max mm	f cm ²	breaking load KN. min.	kg/m =
				mm	inch								
60-H1	72906007	72906057	72906087	19,05	3/4"	12,7	5,94	11,91	28,9	18,08	1,06	49,0	1,70
80-H1	72908007	72908057	72908087	25,40	1"	15,88	7,92	15,88	36,5	24,13	1,79	84,8	2,90
100-H1	72910007	72910057	72910087	31,75	1 1/4"	19,05	9,53	19,05	42,9	30,18	2,62	122,6	4,40
120-H1	72912007	72912057	72912087	38,1	1 1/2"	25,4	11,11	22,22	54,1	36,19	4,0	160,5	6,20

CAD drawings available on our site
www.chiaravalli.com

Quantity, availability and prices
on B2B Chiaravalli



CHAIN PLATE STRAIGHT QRC®

7

CHAINS MANUFACTURED BY AN ISO 9001 CERTIFIED FACTORY

ACCORDING TO ISO 606 - DIN 8187

Pack of 5m

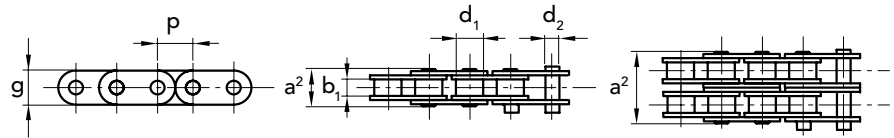

f = resistant surface

CHAIN PLATE STRAIGHT QRC®

SIMPLEX PLATE STRAIGHT

ISO N.	CHAIN P. NUMBER	COUPLING P. NUMBER	OFFSET P. NUMBER	P		b ₁ min. mm	d ₂ mm	d ₁ max mm	a ² max mm	g max mm	f cm ²	breaking load N. mm ²	kg/m =
				mm	inch								
08B1	74112607	74112657	74112687	12,70	1/2"	7,75	4,45	8,51	17,0	11,81	0,5	16,4	0,80
10B1	74115607	74115657	74115687	15,875	5/8"	9,65	5,08	10,16	19,6	14,73	0,67	20,6	1,00
12B1	74119607	74119657	74119687	19,05	3/4"	11,68	5,72	12,07	22,7	16,13	0,89	26,6	1,30
16B1	74125607	74125657	74125687	25,40	1"	11,02	8,28	15,88	36,1	21,08	2,10	52,7	2,90

DUPLEX PLATE STRAIGHT

ISO N.	CHAIN P. NUMBER	COUPLING P. NUMBER	P		b ₁ min. mm	d ₂ mm	d ₁ max mm	a ² max mm	g max mm	f cm ²	breaking load N. mm ²	kg/m =
			mm	inch								
10B2	74215607	74215657	15,88	5/8"	9,65	5,08	10,16	36,2	14,73	1,34	41,1	2,50
12B2	74219607	74219657	19,05	3/4"	11,68	5,72	12,07	42,2	16,13	1,78	53,3	2,60



CHAINS PINS DRILLED QRC®

CHAINS MANUFACTURED BY AN ISO 9001 CERTIFIED FACTORY

ACCORDING TO ISO 606 - DIN 8187

Pack of 5m

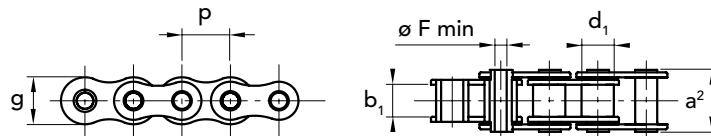

f = resistant surface

CHAINS PINS DRILLED QRC®

PINS DRILLED

RIFERIM. N.	CHAIN P. NUMBER	COUPLING P. NUMBER	OFFSET P. NUMBER	P		b ₁ min. mm	d ₁ mm	a ² max mm	Ø F max mm	g max mm	f cm ²	breaking load N. mm ²	kg/m =
				mm	inch								
08 BHP-1	74112707	74112757	74112787	12,7	1/2"	7,75	8,51	17,00	4,4	11,7	0,7	13,5	0,50
10 BHP-1	74115707	74115757	74115787	15,875	5/8"	9,65	10,16	21,00	5,1	14	1,0	20,0	0,80

Please note: all QRC® chains are subject to pretensioning. This operation is made in order to fix dimension and stretching.

CAD drawings available on our site www.chiaravalli.com

Quantity, availability and prices on B2B Chiaravalli



COUPLING

2 ATTACKS TYPE K



COUPLING

1 ATTACK TYPE A



COUPLING

BOLTS DRILLED



COUPLING

SOLID COUPLING PINS



COUPLING

PIN SURFACE





CHAINS MANUFACTURED
BY AN **ISO 9001** CERTIFIED
FACTORY

Pack of 5m

f = resistant surface

SOLID COUPLING PINS

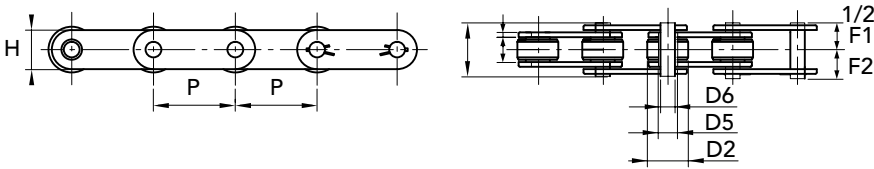

CHAIN	CHAIN P. NUMBER	COUPLING P. NUMBER	P mm	L mm	D2 mm	D5 mm	D6 mm	H mm	S mm	F1 mm	F2 mm	breaking load N. mm ²	kg/m catena
1,1205	74502050	74502055	50	11,5	25	8,35	5,7	18	2,5	25,5	15,4	18,0	1,70
1,1206	74502060	74502065	50	11,5	25	11	8	20	3	28,8	16,5	22,0	2,10
1,1400	74504000	74504005	50	15	31	13,2	10	23	3	32,6	19,2	32,0	3,00
1,1500	74505000	74505005	50	15	31	13,2	10	25	4	36,6	20,7	40,0	3,90
1,1505	74505020	74505025	100	15	31	13,2	10	25	4	36,6	20,7	40,0	2,90
1,1703	74507030	74507035	100	22	40	17	12	35	4	44	25	75,0	4,90

SOLID COUPLING PINS TIPE "B"

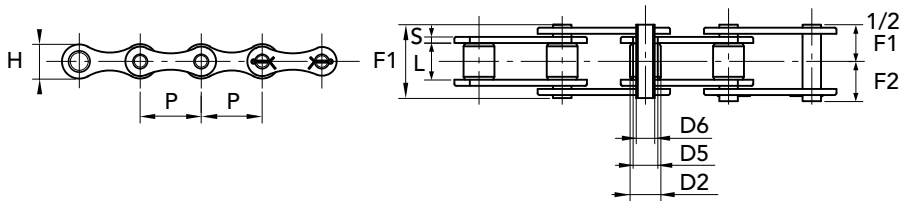

CHAIN	CHAIN P. NUMBER	COUPLING P. NUMBER	P mm	L mm	D2 mm	D5 mm	D6 mm	H mm	S mm	F1 mm	F2 mm	breaking load N. mm ²	kg/m catena
1,1400 B	74514000	74514005	50	15	31	13,2	10	23	3	32,6	19,2	32,0	2,50

SOLID COUPLING PINS WITH ATTACHMENTS

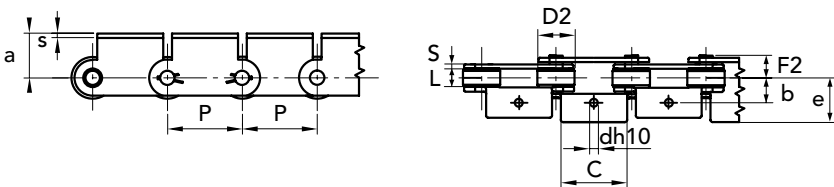

CHAIN	CHAIN P. NUMBER	COUPLING P. NUMBER	P mm	D2 mm	a mm	b mm	c mm	d mm	e mm	s mm	L mm	F2 mm	breaking load N. mm ²	kg/m attacco
1.1205 A1-01	74522050	74522055	50	25	24	22	46	6,5	36	2,5	11,5	12,75	18,0	2,51

CAD drawings available on our site
www.chiaravalli.com

Quantity, availability and prices
on B2B Chiaravalli



CHAINS MANUFACTURED
BY AN **ISO 9001** CERTIFIED
FACTORY

Pack of 5m

f = resistant surface

SOLID COUPLING PINS WITH ATTACHMENTS

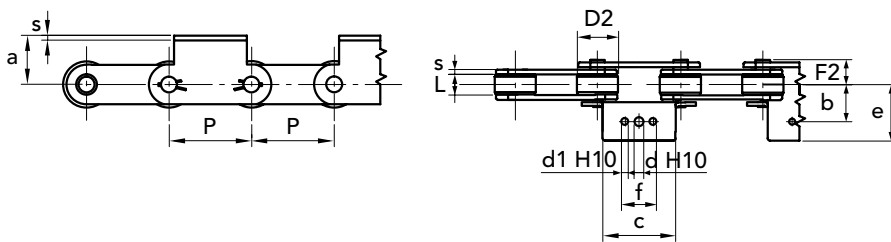

CHAIN	CHAIN P. NUMBER	COUPLING P. NUMBER	P mm	D2 mm	a mm	b mm	c mm	d mm	e mm	s mm	d1 mm	f mm	L mm	F2 mm	breaking load N. mm ²	kg/m
1.1205 A1-02	74532050	74522055	50	25	24	22	46	6,5	36	2,5	-	-	11,5	12,75	18,0	2,50
1.1400 A3-02	74534000	74534005	50	31	35	31	60	10,5	48,5	3	8,5	25	15	16,3	32,0	4,23
1.1500 A3-02	74535000	74535005	50	31	35	32	45	10,5	48	4	8,5	25	15	18,7	40,0	4,63

SOLID COUPLING PINS WITH ATTACHMENTS

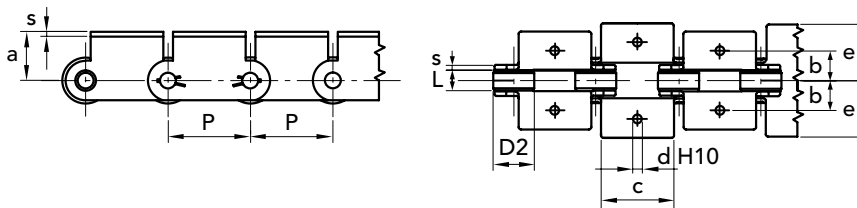

CHAIN	CHAIN P. NUMBER	COUPLING P. NUMBER	P mm	D2 mm	a mm	b mm	c mm	d mm	e mm	s mm	L mm	breaking load N. mm ²	kg/m
1.1205 K1-01	74542050	74542055	50	25	24	22	46	6,5	36	2,5	11,5	18,0	3,19

SOLID COUPLING PINS WITH ATTACHMENTS

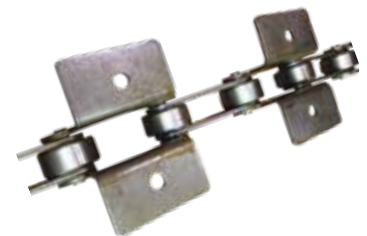
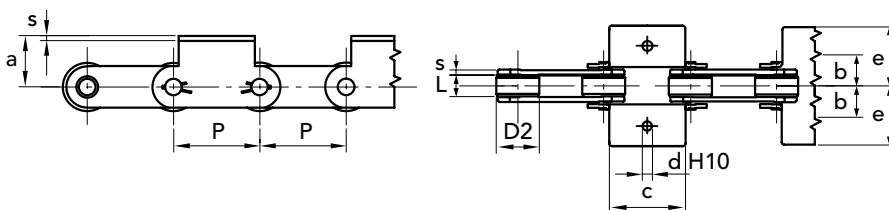

CHAIN	CHAIN P. NUMBER	COUPLING P. NUMBER	P mm	D2 mm	a mm	b mm	c mm	d mm	e mm	s mm	L mm	breaking load N. mm ²	kg/m
1.1205 K1-02	74552050	74542055	50	25	24	22	46	6,5	36	2,5	11,5	18,0	2,50

CAD drawings available on our site
www.chiaravalli.com

Quantity, availability and prices
on B2B Chiaravalli



CHAINS MANUFACTURED
BY AN **ISO 9001** CERTIFIED
FACTORY

Pack of 5m

f = resistant surface

STUD PIERCED

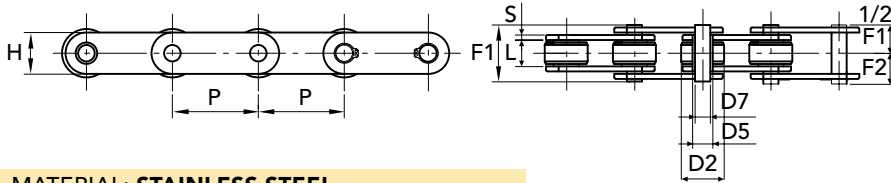

MATERIAL: **STAINLESS STEEL**

CHAIN	CHAIN P. NUMBER	COUPLING P. NUMBER	P mm	L mm	D2 mm	D5 mm	D6 mm	D7 mm	H mm	S mm	F1 mm	F2 mm	breaking load N. mm ²	kg/m chain
1.2250	74602500	74602505	50	11,5	25	11	9	6,2	20	2,5	26	14,5	30,0	1,80
1.2250 SS	74695400	74695405	50	11,5	25	11	9	6,2	20	2,5	26	14,5	20,0	1,80
1.2400	74604000	74604005	50	15	31	17	14	10,2	25	3	31	17,5	35,0	3,00
1.2500	74605000	74605005	50	15	31	17	14	10,2	25	4	35	19,5	40,0	3,60
1.2501	74605010	74605015	75	15	31	17	14	10,2	25	4	35	19,5	40,0	3,10
1.2502	74605020	74605025	100	15	31	17	14	10,2	25	4	35	19,5	40,0	2,60

STUD PIERCED

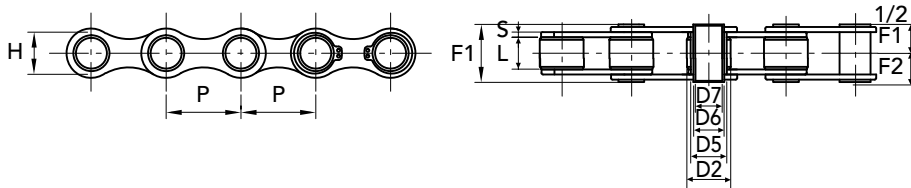

CHAIN	CHAIN P. NUMBER	COUPLING P. NUMBER	P mm	L mm	D2 mm	D5 mm	D6 mm	D7 mm	H mm	S mm	F1 mm	F2 mm	breaking load N. mm ²	kg/m chain
1.3520 R	74605200	74605205	35	16	20	17	14	10,2	26	2,5	30	16,7	25,0	2,20
1.3520 Z	74615200	74615205	35	16	20	17	14	10,2	26	2,5	30	16,7	25,0	2,20

A GALVANIZED BOLTS DRILLED

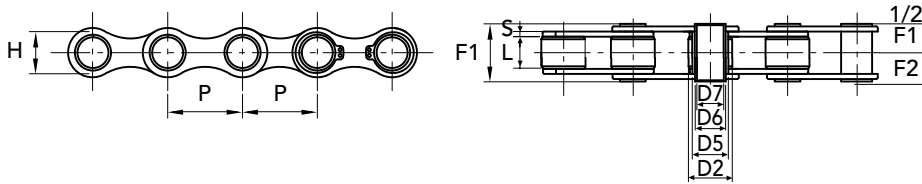

CHAIN	CHAIN P. NUMBER	COUPLING P. NUMBER	P mm	L mm	D2 mm	D5 mm	D6 mm	D7 mm	H mm	S mm	F1 mm	F2 mm	breaking load N. mm ²	kg/m chain
1.1260 Z	74612600	74612605	41,75	20,5	17	13,8	11	8,3	21,4	3	36	22,7	27,0	1,50

A PINS, PROJECTIONS GALVANIZED

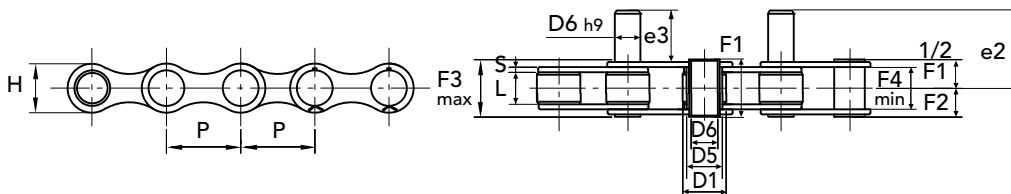

CHAIN	CHAIN P. NUMBER	COUPLING P. NUMBER	P mm	L mm	D1 mm	D5 mm	D6 mm	e2 mm	H mm	S mm	F1 mm	F2 mm	e3 mm	F3max mm	F4 min mm	breaking load N. mm ²	kg/m chain
1.3521 Z	74615210	74615215	35	16	20	13	10	48,5	26	2,5	31	19	35	21	21,5	35,0	2,80

CAD drawings available on our site
www.chiaravalli.com

Quantity, availability and prices
on B2B Chiaravalli

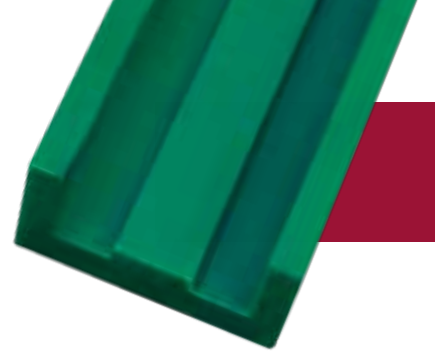

POLYETHYLENE GUIDES METAL STEEL HOLDERS

POLYETHYLENE GUIDES FOR CHAINS

PROFILE T1	page 3
PROFILE T2	4
PROFILE T3	5
PROFILE T1C - T2C	6
PROFILE E1 -E2	7
PROFILE E1C	8
PROFILE BL	9
PROFILE BLC	10
PROFILE U	11

POLYETHYLENE GUIDES FOR FLAT BELTS

PROFILE PC	12
------------	----

POLYETHYLENE GUIDES FOR TOOTHED BELTS

PROFILE SF	13
PROFILE SFC	14

POLYETHYLENE GUIDES FOR TRAPEZOIDAL BELTS

PROFILE V	15
PROFILE VC	16

METAL STEEL HOLDERS

17



POLYETHYLENE GUIDES - METAL STEEL HOLDERS

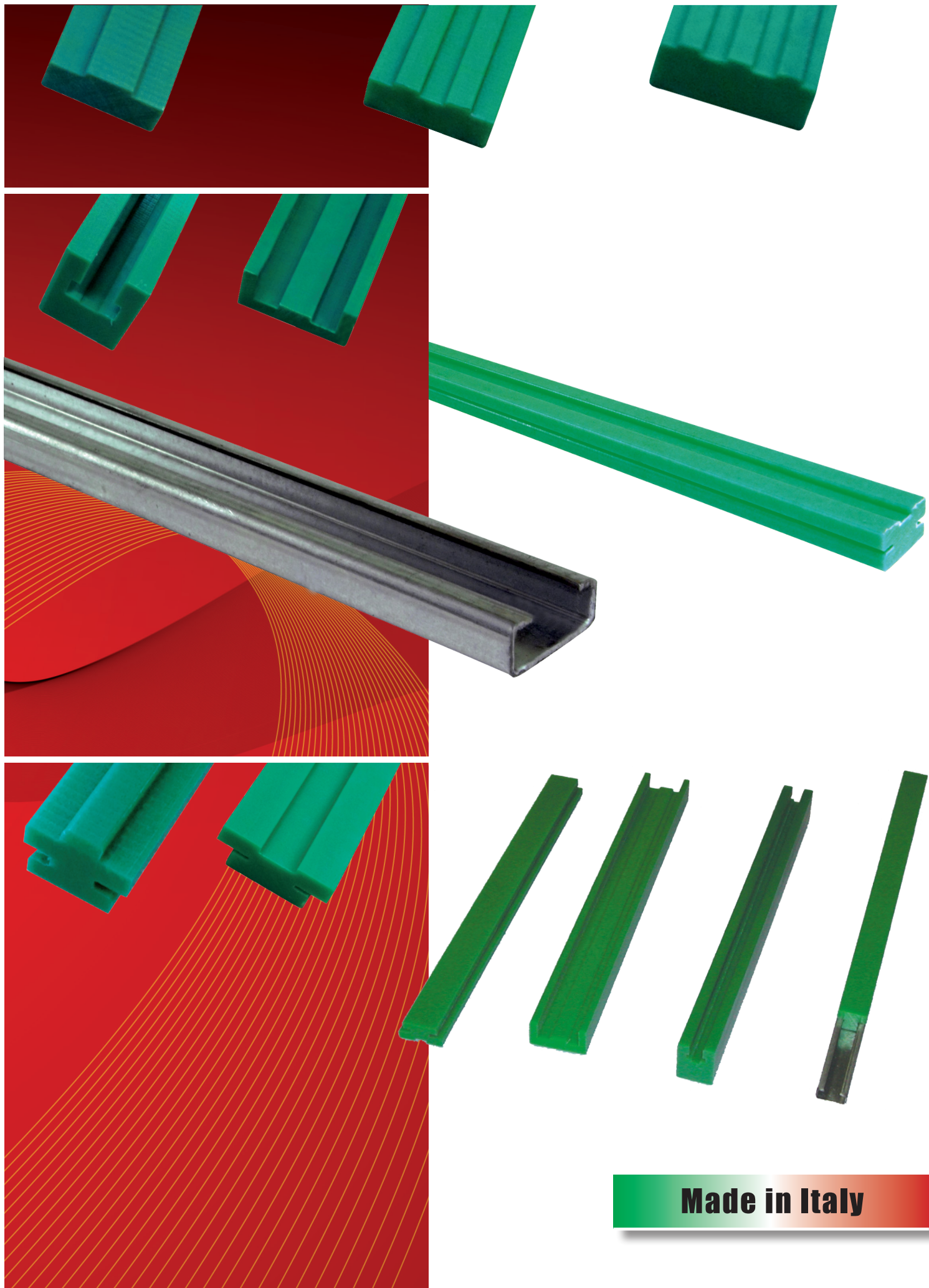

Made in Italy



PROFILE T1

MADE IN ITALY

Standard lengths 2 METERS

(on request we provide higher lengths)

Material: PE-UHMW High molecular weight polyethylene (p.m. over 1.000.000)

Color: green

Specific gravity: g/cm³ 0,945Dynamic friction coefficient: 0.2 (P = 0.05 N/mm² - V = 0.6 m/s - T = 40°C)

Temperature range : -70°C ÷ 65°C

Linear thermal expansion: mm 2 every 10°C from the temperature of 20°C.

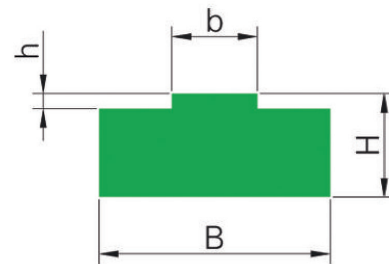
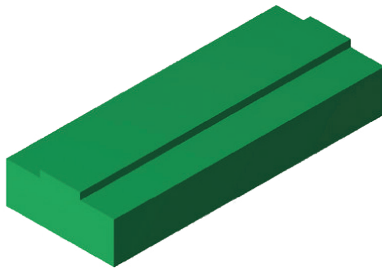

DESCRIPTION	ARTICLE CODE	CHAIN	ISO 606 (DIN 8187)	B	H	b	h	WEIGHT
				mm	mm	mm	mm	Kg/piece
T1-01	GC 1 05 01 2	3/8"x7/32"	06 B-1	15.0	10.0	5.4	1.5	0,26
T1-05	GC 1 05 05 2	1/2"x5/16"	08 B-1	20.0	10.0	7.4	2.2	0,33
T1-06	GC 1 05 06 2	1/2"x5/16"	08 B-1	20.0	15.0	7.4	2.2	0,52
T1-07	GC 1 05 07 2	1/2"x5/16"	08 B-1	20.0	20.0	7.4	2.2	0,70
T1-09	GC 1 05 09 2	5/8"x3/8"	10 B-1	20.0	10.0	9.2	2.6	0,32
T1-10	GC 1 05 10 2	5/8"x3/8"	10 B-1	20.0	15.0	9.2	2.6	0,52
T1-11	GC 1 05 11 2	5/8"x3/8"	10 B-1	20.0	20.0	9.2	2.6	0,71
T1-13	GC 1 05 13 2	3/4"x7/16"	12 B-1	25.0	10.0	11.3	2.4	0,42
T1-14	GC 1 05 14 2	3/4"x7/16"	12 B-1	25.0	15.0	11.3	2.4	0,65
T1-15	GC 1 05 15 2	3/4"x7/16"	12 B-1	25.0	20.0	11.3	2.4	0,88
T1-18	GC 1 05 18 2	1"x17 mm	16 B-1	40.0	15.0	16.5	3.5	0,94
T1-19	GC 1 05 19 2	1"x17 mm	16 B-1	40.0	20.0	16.5	3.5	1,32
T1-21	GC 1 05 21 2	1 1/4"x3/4"	20 B-1	45.0	15.0	19.0	4.3	1,06
T1-22	GC 1 05 22 2	1 1/4"x3/4"	20 B-1	45.0	20.0	19.0	4.3	1,49
T1-24	GC 1 05 24 2	1 1/2"x1"	24 B-1	60.0	15.0	24.6	5.6	1,33
T1-25	GC 1 05 25 2	1 1/2"x1"	24 B-1	60.0	20.0	24.6	5.6	1,90
T1-27	GC 1 05 27 2	1 3/4"x31 mm	28 B-1	75.0	20.0	30.0	6.9	2,26
T1-30	GC 1 05 30 2	2"x31 mm	32 B-1	80.0	20.0	30.0	7.8	2,30

Note: all value have been measured in standard weather conditions: 23°C/73°F with 50% relative humidity (DIN 50005/ISO 554)



PROFILE T2

MADE IN ITALY

Standard lengths 2 METERS

(on request we provide higher lengths)

Material: PE-UHMW High molecular weight polyethylene (p.m. over 1.000.000)

Color: green

Specific gravity: g/cm³ 0,945Dynamic friction coefficient: 0.2 (P = 0.05 N/mm² - V = 0.6 m/s - T = 40°C)

Temperature range : -70°C ÷ 65°C

Linear thermal expansion: mm 2 every 10°C from the temperature of 20°C.

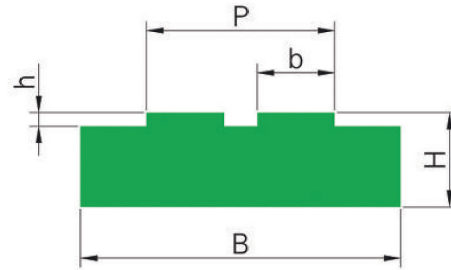
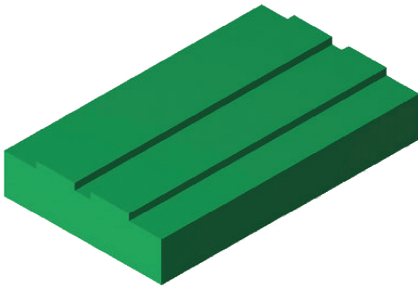

DESCRIPTION	ARTICLE CODE	CHAIN	ISO 606 (DIN 8187)	B	H	b	h	P	WEIGHT
				mm	mm	mm	mm	mm	Kg/piece
T2-01	GC 1 10 01 2	3/8"x7/32"	06 B-2	25.0	10.0	5.4	1.5	15.8	0,50
T2-05	GC 1 10 05 2	1/2"x5/16"	08 B-2	35.0	10.0	7.4	2.2	21.4	0,72
T2-06	GC 1 10 06 2	1/2"x5/16"	08 B-2	35.0	15.0	7.4	2.2	21.4	1,06
T2-07	GC 1 10 07 2	1/2"x5/16"	08 B-2	35.0	20.0	7.4	2.2	21.4	1,38
T2-09	GC 1 10 09 2	5/8"x3/8"	10 B-2	40.0	10.0	9.2	2.6	25.8	0,85
T2-10	GC 1 10 10 2	5/8"x3/8"	10 B-2	40.0	15.0	9.2	2.6	25.8	1,23
T2-11	GC 1 10 11 2	5/8"x3/8"	10 B-2	40.0	20.0	9.2	2.6	25.8	1,61
T2-13	GC 1 10 13 2	3/4"x7/16"	12 B-2	45.0	15.0	11.3	2.4	30.8	1,19
T2-14	GC 1 10 14 2	3/4"x7/16"	12 B-2	45.0	20.0	11.3	2.4	30.8	1,62
T2-15	GC 1 10 15 2	1"x17 mm	16 B-2	65.0	15.0	16.5	3.5	48.4	1,88
T2-18	GC 1 10 18 2	1"x17 mm	16 B-2	65.0	20.0	16.5	3.5	48.4	2,30
T2-19	GC 1 10 19 2	1 1/4"x3/4"	20 B-2	70.0	15.0	19.0	4.3	54.5	1,85
T2-21	GC 1 10 21 2	1 1/4"x3/4"	20 B-2	70.0	20.0	19.0	4.3	54.5	2,51
T2-22	GC 1 10 22 2	1 1/2"x1"	24 B-2	88.0	20.0	24.6	5.6	73.0	3,16
T2-24	GC 1 10 24 2	1 3/4"x31 mm	28 B-2	105.0	25.0	30.0	6.9	89.6	4,68
T2-25	GC 1 10 25 2	2"x31 mm	32 B-2	105.0	30.0	30.0	7.8	88.7	5,68

Note: all value have been measured in standard weather conditions: 23°C/73°F with 50% relative humidity (DIN 50005/ISO 554)



PROFILE T3

MADE IN ITALY

Standard lengths 2 METERS

(on request we provide higher lengths)

Material: PE-UHMW High molecular weight polyethylene (p.m. over 1.000.000)

Color: green

Specific gravity: g/cm³ 0,945Dynamic friction coefficient: 0.2 (P = 0.05 N/mm² - V = 0.6 m/s - T = 40°C)

Temperature range : -70°C ÷ 65°C

Linear thermal expansion: mm 2 every 10°C from the temperature of 20°C.

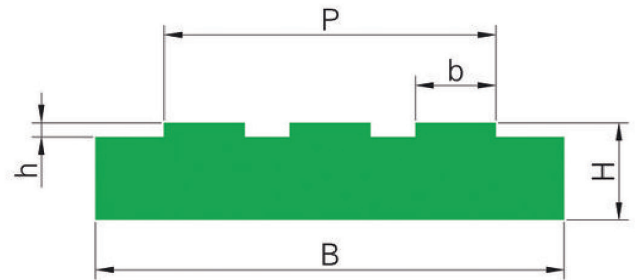
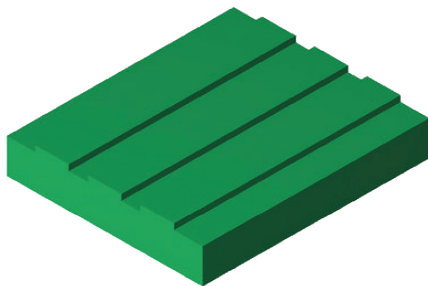

DESCRIPTION	ARTICLE CODE	CHAIN	ISO 606 (DIN 8187)	B	H	b	h	P	WEIGHT
				mm	mm	mm	mm	mm	Kg/piece
T3-01	GC 1 15 01 2	3/8"x7/32"	06 B-3	35.0	10.0	5.4	1.5	25.9	0,61
T3-05	GC 1 15 05 2	1/2"x5/16"	08 B-3	45.0	10.0	7.4	2.2	35.2	0,76
T3-06	GC 1 15 06 2	1/2"x5/16"	08 B-3	45.0	15.0	7.4	2.2	35.2	1,19
T3-07	GC 1 15 07 2	1/2"x5/16"	08 B-3	45.0	20.0	7.4	2.2	35.2	1,62
T3-09	GC 1 15 09 2	5/8"x3/8"	10 B-3	55.0	10.0	9.2	2.6	42.4	0,91
T3-10	GC 1 15 10 2	5/8"x3/8"	10 B-3	55.0	15.0	9.2	2.6	42.4	1,60
T3-11	GC 1 15 11 2	5/8"x3/8"	10 B-3	55.0	20.0	9.2	2.6	42.4	2,18
T3-13	GC 1 15 13 2	3/4"x7/16"	12 B-3	60.0	15.0	11.3	2.4	50.2	1,76
T3-14	GC 1 15 14 2	3/4"x7/16"	12 B-3	60.0	20.0	11.3	2.4	50.2	2,39
T3-15	GC 1 15 15 2	1"x17 mm	16 B-3	95.0	20.0	16.5	3.5	80.3	3,53

Note: all value have been measured in standard weather conditions: 23°C/73°F with 50% relative humidity (DIN 50005/ISO 554)



PROFILES T1C - T2C

MADE IN ITALY

Standard lengths 2 METERS

(on request we provide higher lengths)

Material: PE-UHMW High molecular weight polyethylene (p.m. over 1.000.000)

Color: green

Specific gravity: g/cm³ 0,945

Dynamic friction coefficient: 0.2 (P = 0.05 N/mm² - V = 0.6 m/s - T = 40°C)

Temperature range : -70°C ÷ 65°C

Linear thermal expansion: mm 2 every 10°C from the temperature of 20°C.

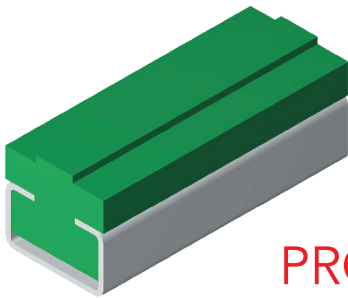

PROFILE T1C

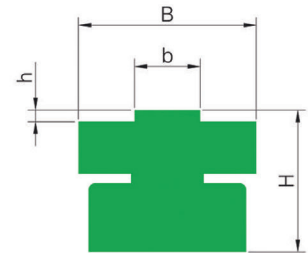
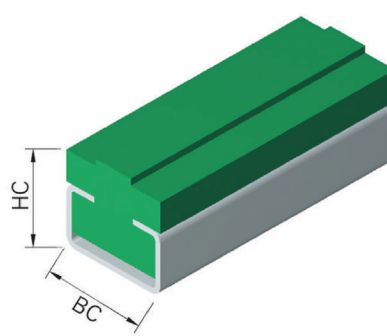

DESCRIPTION	ARTICLE CODE	CHAIN	ISO 606 (DIN 8187)	B	H	BC	HC	b	h	METALLIC PROFILE	WEIGHT
				mm	mm	mm	mm	mm	mm		Kg/piece
T1C-31	GC 1 20 31 2	3/8"x7/32"	06 B-1	20.0	15.0	20.0	17.0	5.4	1.5	C 3	0,25
T1C-33	GC 1 20 33 2	1/2"x5/16"	08 B-1	20.0	15.0	20.0	17.0	7.4	2.2	C 3	0,26
T1C-34	GC 1 20 34 2	5/8"x3/8"	10 B-1	20.0	15.0	20.0	17.0	9.2	2.6	C 3	0,27
T1C-35	GC 1 20 35 2	3/4"x7/16"	12 B-1	20.0	15.0	20.0	17.0	11.3	2.4	C 3	0,35
T1C-36	GC 1 20 36 2	1"x17 mm	16 B-1	28.0	15.0	28.0	18.0	16.5	3.5	C 5	0,59
T1C-37	GC 1 20 37 2	1 1/4"x3/4"	20 B-1	38.0	20.0	38.0	27.0	19.0	4.3	C 9	1,27

METALLIC PROFILE NOT INCLUDED

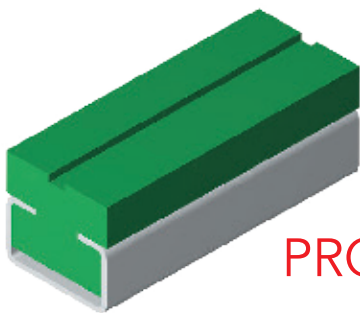

PROFILE T2C

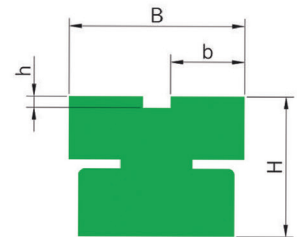
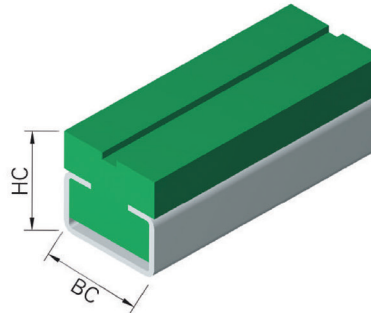

DESCRIPTION	ARTICLE CODE	CHAIN	ISO 606 (DIN 8187)	B	H	BC	HC	b	h	METALLIC PROFILE	WEIGHT
				mm	mm	mm	mm	mm	mm		Kg/piece
T2C-31	GC 1 25 31 2	3/8"x7/32"	06 B-2	15.7	15.0	20.0	17.0	5.4	1.5	C 3	0,41
T2C-33	GC 1 25 33 2	1/2"x5/16"	08 B-2	21.4	15.0	20.0	17.0	7.4	2.2	C 3	0,48
T2C-34	GC 1 25 34 2	5/8"x3/8"	10 B-2	25.9	15.0	28.0	19.0	9.2	2.6	C 5	0,52
T2C-35	GC 1 25 35 2	3/4"x7/16"	12 B-2	30.7	15.0	28.0	19.0	11.3	2.4	C 5	0,66
T2C-36	GC 1 25 36 2	1"x17 mm	16 B-2	48.3	20.0	38.0	27.0	16.5	3.5	C 9	1,30

METALLIC PROFILE NOT INCLUDED

Note: all value have been measured in standard weather conditions: 23°C/73°F with 50% relative humidity (DIN 50005/ISO 554)



PROFILES E1 - E2

MADE IN ITALY

Standard lengths 2 METERS

(on request we provide higher lengths)

Material: PE-UHMW High molecular weight polyethylene (p.m. over 1.000.000)

Color: green

Specific gravity: g/cm³ 0,945

Dynamic friction coefficient: 0.2 (P = 0.05 N/mm² - V = 0.6 m/s - T = 40°C)

Temperature range : -70°C ÷ 65°C

Linear thermal expansion: mm 2 every 10°C from the temperature of 20°C.

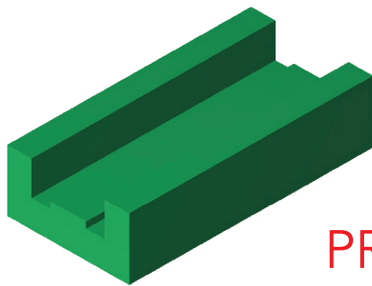

PROFILE E1

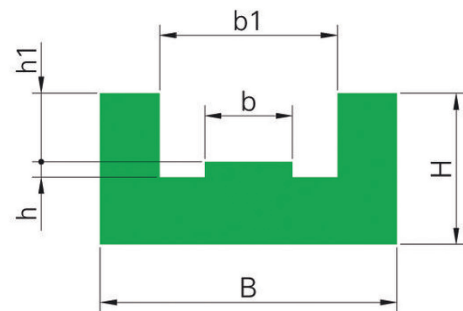

DESCRIPTION	ARTICLE CODE	CHAIN	ISO 606 (DIN 8187)	B	H	b1	h1	b	h	WEIGHT
				mm	mm	mm	mm	mm	mm	Kg/piece
E1-01	GC 1 30 01 2	3/8"x7/32"	06 B-1	25.0	10.0	15.0	4.4	5.4	1.5	0,41
E1-05	GC 1 30 05 2	1/2"x5/16"	08 B-1	30.0	15.0	20.0	7.2	7.4	2.2	0,79
E1-06	GC 1 30 06 2	5/8"x3/8"	10 B-1	33.0	20.0	23.0	9.5	9.2	2.6	1,18
E1-07	GC 1 30 07 2	3/4"x7/16"	12 B-1	38.0	20.0	28.0	11.1	11.3	2.4	1,31
E1-10	GC 1 30 10 2	1"x17 mm	16 B-1	51.0	25.0	41.0	16.5	16.5	3.5	2,35

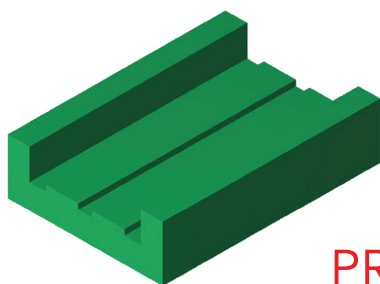

PROFILE E2

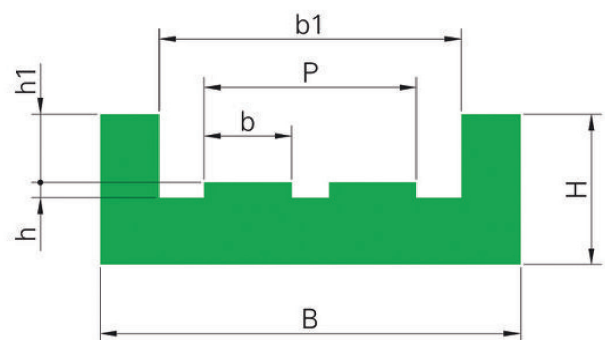

DESCRIPTION	ARTICLE CODE	CHAIN	ISO 606 (DIN 8187)	B	H	b1	h1	b	h	P	WEIGHT
				mm	mm	mm	mm	mm	mm	mm	Kg/piece
E2-01	GC 1 35 01 2	3/8"x7/32"	06 B-2	36.0	15.0	26.0	4.4	5.4	1.5	15.8	0,94
E2-05	GC 1 35 05 2	1/2"x5/16"	08 B-2	45.0	20.0	35.0	7.2	7.4	2.2	21.4	1,38
E2-06	GC 1 35 06 2	5/8"x3/8"	10 B-2	50.0	25.0	40.0	9.5	9.2	2.6	25.8	1,83
E2-07	GC 1 35 07 2	3/4"x7/16"	12 B-2	56.0	25.0	46.0	11.1	11.3	2.4	30.8	1,87
E2-10	GC 1 35 10 2	1"x17 mm	16 B-2	85.0	30.0	75.0	16.5	16.5	3.5	48.8	2,56

Note: all value have been measured in standard weather conditions: 23°C/73°F with 50% relative humidity (DIN 50005/ISO 554)



PROFILE E1C

MADE IN ITALY

Standard lengths 2 METERS

(on request we provide higher lengths)

Material: PE-UHMW High molecular weight polyethylene (p.m. over 1.000.000)

Color: green

Specific gravity: g/cm³ 0,945

Dynamic friction coefficient: 0.2 (P = 0.05 N/mm² - V = 0.6 m/s - T = 40°C)

Temperature range : -70°C ÷ 65°C

Linear thermal expansion: mm 2 every 10°C from the temperature of 20°C.

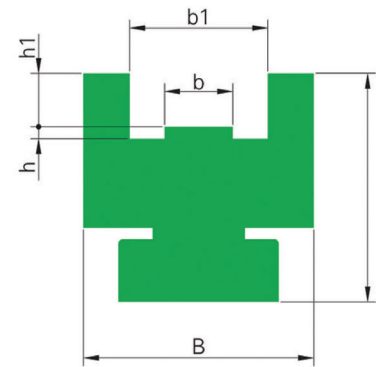
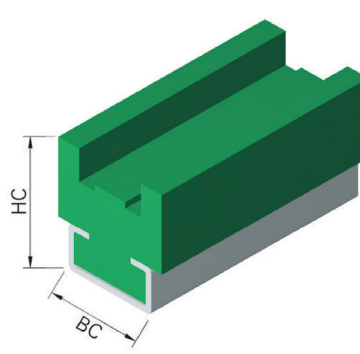
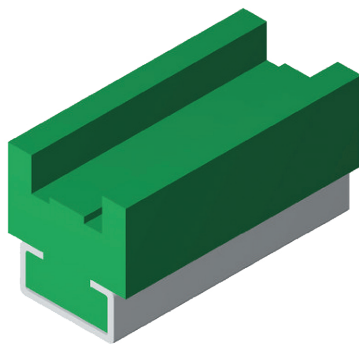

DESCRIPTION	ARTICLE CODE	CHAIN	ISO 606 (DIN 8187)	B	H	BC	HC	b1	h1	b	h	METALLIC PROFILE	WEIGHT
				mm	mm	mm	mm	mm	mm	mm	mm		Kg/piece
E1C-01	GC 1 40 01 2	3/8"x7/32"	06 B-1	25.0	18.0	20.0	20.0	15.0	4.4	5.4	1.5	C-3	0,67
E1C-05	GC 1 40 05 2	1/2"x5/16"	08 B-1	30.0	25.0	20.0	27.0	20.0	7.2	7.4	2.2	C-3	1,05
E1C-06	GC 1 40 06 2	5/8"x3/8"	10 B-1	33.0	30.0	28.0	32.0	23.0	9.5	9.2	2.6	C-5	1,65
E1C-07	GC 1 40 07 2	3/4"x7/16"	12 B-1	38.0	35.0	38.0	38.5	28.0	11.1	11.3	2.4	C-9	2,31
E1C-10	GC 1 40 10 2	1"x17 mm	16 B-1	51.0	40.0	38.0	43.5	41.0	16.5	16.5	3.5	C-9	3,54

METALLIC PROFILE NOT INCLUDED

Note: all value have been measured in standard weather conditions: 23°C/73°F with 50% relative humidity (DIN 50005/ISO 554)

Quantity, availability and prices on B2B Chiaravalli



PROFILE BL

MADE IN ITALY

Standard lengths 2 METERS

(on request we provide higher lengths)

Material: PE-UHMW High molecular weight polyethylene (p.m. over 1.000.000)

Color: green

Specific gravity: g/cm³ 0,945Dynamic friction coefficient: 0.2 (P = 0.05 N/mm² - V = 0.6 m/s - T = 40°C)

Temperature range : -70°C ÷ 65°C

Linear thermal expansion: mm 2 every 10°C from the temperature of 20°C.

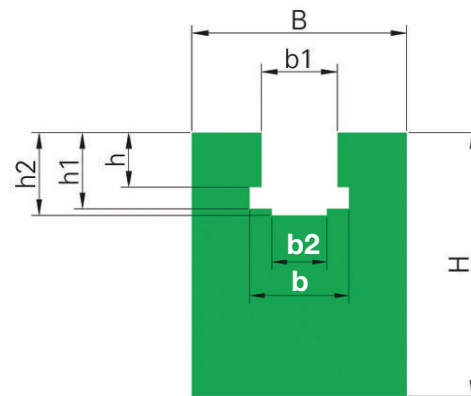
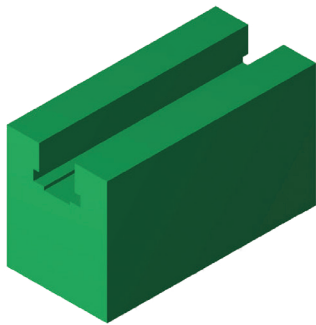

DESCRIPTION	ARTICLE CODE	CHAIN	ISO 606 (DIN 8187)	B	H	b1	b2	h1	h2	b	h	WEIGHT
				mm	mm	mm	mm	mm	mm	mm	mm	Kg/pezzo
BL-01	GC 1 45 01 2	3/8"x7/32"	06 B-1	20.0	25.0	6.6	4.0	8.7	10.0	9.3	5.6	0,81
BL-05	GC 1 45 05 2	1/2"x5/16"	08 B-1	24.0	30.0	8.7	5.0	11.5	13.5	12.8	7.6	1,15
BL-09	GC 1 45 09 2	5/8"x3/8"	10 B-1	30.0	35.0	10.4	6.0	13.5	14.8	15.4	9.5	1,66
BL-15	GC 1 45 15 2	3/4"x7/16"	12 B-1	40.0	35.0	12.3	7.0	15.9	17.5	16.9	11.5	2,21
BL-18	GC 1 45 18 2	1"x17 mm	16 B-1	40.0	45.0	16.1	9.0	25.7	26.8	24.4	16.1	2,46
BL-21	GC 1 45 21 2	1 1/4"x3/4"	20 B-1	50.0	50.0	19.3	11.0	29.3	31.2	27.5	19.4	3,45
BL-24	GC 1 45 24 2	1 1/2"x1"	24 B-1	60.0	60.0	25.7	16.0	38.2	40.1	36.5	25.2	4,66
BL-25	GC 1 45 25 2	1 3/4"x31 mm	28 B-1	60.0	70.0	28.3	17.0	46.9	48.9	41.5	30.8	4,95
BL-30	GC 1 45 30 2	2"x31 mm	32 B-1	70.0	75.0	29.6	19.0	47.3	53.0	44.5	30.8	6,53

Note: all value have been measured in standard weather conditions: 23°C/73°F with 50% relative humidity (DIN 50005/ISO 554)

Quantity, availability and prices on B2B Chiaravalli



PROFILE BLC

MADE IN ITALY

Standard lengths 2 METERS

(on request we provide higher lengths)

Material: PE-UHMW High molecular weight polyethylene (p.m. over 1.000.000)

Color: green

Specific gravity: g/cm³ 0,945Dynamic friction coefficient: 0.2 (P = 0.05 N/mm² - V = 0.6 m/s - T = 40°C)

Temperature range : -70°C ÷ 65°C

Linear thermal expansion: mm 2 every 10°C from the temperature of 20°C.

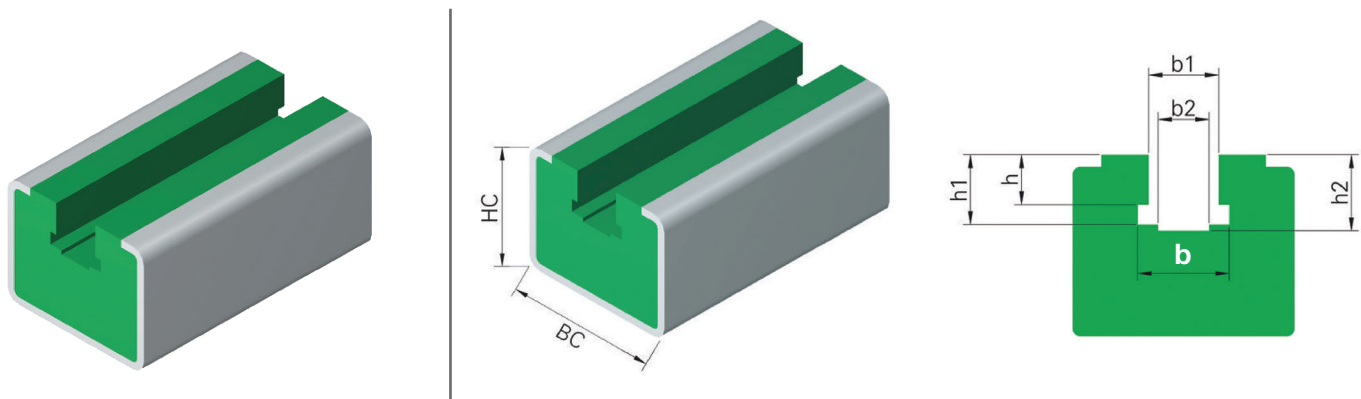

DESCRIPTION	ARTICLE CODE	CHAIN	ISO 606 (DIN 8187)	BC	HC	b1	b2	h1	h2	b	h	METALLIC PROFILE	WEIGHT
				mm	mm	mm	mm	mm	mm	mm	mm		Kg/piece
BLC-01	GC 1 50 01 2	3/8"x7/32"	06 B-1	30.0	24.0	6.6	4.0	8.7	10.0	9.3	5.6	C-10	0,81
BLC-05	GC 1 50 05 2	1/2"x5/16"	08 B-1	30.0	24.0	8.7	5.0	11.5	13.5	12.8	7.6	C-10	0,81
BLC-09	GC 1 50 09 2	5/8"x3/8"	10 B-1	30.0	24.0	10.4	6.0	13.5	14.8	15.4	9.5	C-10	0,81
BLC-15	GC 1 50 15 2	3/4"x7/16"	12 B-1	30.0	24.0	12.3	7.0	15.9	17.5	16.9	11.5	C-10	0,81
BLC-18	GC 1 50 18 2	1"x17 mm	16 B-1	45.0	40.0	16.1	9.0	25.7	26.8	24.4	16.1	C-11	2,22
BLC-21	GC 1 50 21 2	1 1/4"x3/4"	20 B-1	45.0	40.0	19.3	11.0	29.3	31.2	27.5	19.5	C-11	2,00

METALLIC PROFILE NOT INCLUDED**Note:** all value have been measured in standard weather conditions: 23°C/73°F with 50% relative humidity (DIN 50005/ISO 554)

Quantity, availability and prices on B2B Chiaravalli



PROFILE U

MADE IN ITALY

Standard lengths 2 METERS

(on request we provide higher lengths)

Material: PE-UHMW High molecular weight polyethylene (p.m. over 1.000.000)

Color: green

Specific gravity: g/cm³ 0,945

Dynamic friction coefficient: 0.2 (P = 0.05 N/mm² - V = 0.6 m/s - T = 40°C)

Temperature range : -70°C ÷ 65°C

Linear thermal expansion: mm 2 every 10°C from the temperature of 20°C.

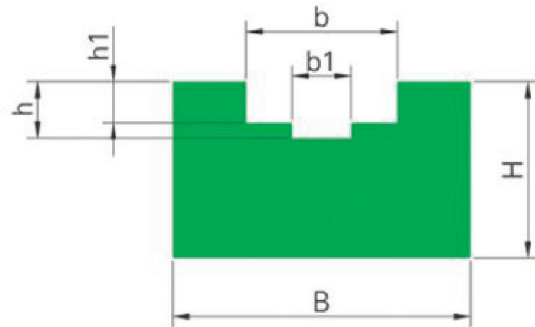
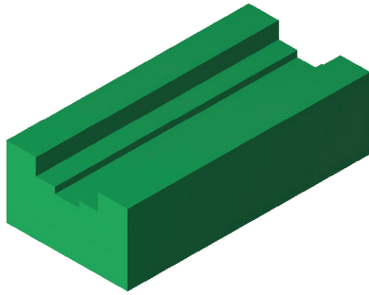

DESCRIPTION	ARTICLE CODE	CHAIN	ISO 606 (DIN 8187)	B	H	B	b1	h	h1	WEIGHT
				mm	mm	mm	mm	mm	mm	Kg/piece
U-01	GC 1 55 01 2	3/8"x7/32"	06 B-1	20	15	9.2	4.0	4.2	2.8	0,52
U-02	GC 1 55 02 2	1/2"x5/16"	08 B-1	25	15	12.7	5.0	4.8	3.5	0,62
U-03	GC 1 55 03 2	5/8"x3/8"	10 B-1	25	15	15.2	6.0	5.1	3.6	0,59
U-04	GC 1 55 04 2	3/4"x7/16"	12 B-1	25	20	16.7	7.0	5.7	3.9	0,81
U-05	GC 1 55 05 2	1"x17 mm	16 B-1	35	25	24.2	9.0	10.0	8.4	1,25

Note: all value have been measured in standard weather conditions: 23°C/73°F with 50% relative humidity (DIN 50005/ISO 554)

Quantity, availability and prices on B2B Chiaravalli



PROFILE PC

MADE IN ITALY

Standard lengths 2 METERS

(on request we provide higher lengths)

Material: PE-UHMW High molecular weight polyethylene (p.m. over 1.000.000)

Color: green

Specific gravity: g/cm³ 0,945

Dynamic friction coefficient: 0.2 (P = 0.05 N/mm² - V = 0.6 m/s - T = 40°C)

Temperature range : -70°C ÷ 65°C

Linear thermal expansion: mm 2 every 10°C from the temperature of 20°C.

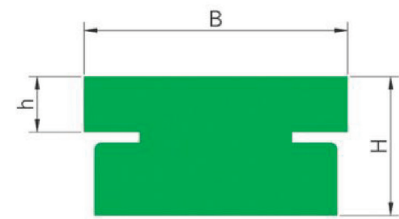
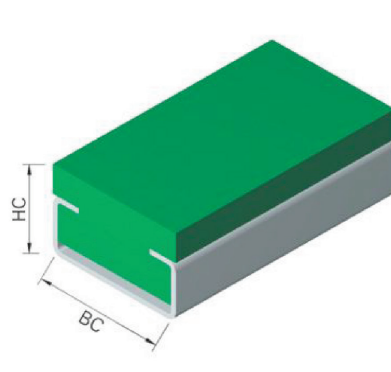
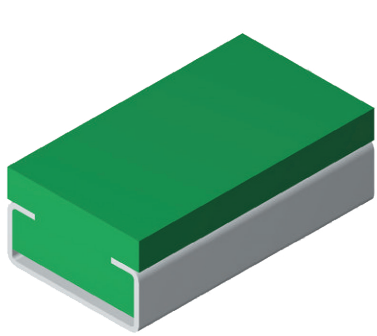

DESCRIPTION	ARTICLE CODE	B	H	BC	HC	h	METALLIC PROFILE	WEIGHT
		mm	mm	mm	mm	mm		Kg/piece
PC-01	GC 2 60 01 2	20.0	10.0	20.0	14.0	4.0	C-3	0,36
PC-02	GC 2 60 02 2	20.0	15.0	20.0	17.0	7.0	C-3	0,50
PC-03	GC 2 60 03 2	20.0	20.0	20.0	22.0	12.0	C-3	0,73
PC-04	GC 2 60 04 2	28.0	10.0	28.0	15.0	3.0	C-5	0,53
PC-05	GC 2 60 05 2	28.0	15.0	28.0	18.0	6.0	C-5	0,80
PC-06	GC 2 60 06 2	28.0	20.0	28.0	24.0	12.0	C-5	1,06
PC-07	GC 2 60 07 2	38.0	10.0	38.0	21.0	3.0	C-9	0,66
PC-08	GC 2 60 08 2	38.0	15.0	38.0	24.0	6.0	C-9	1,01
PC-09	GC 2 60 09 2	38.0	20.0	38.0	30.0	12.0	C-9	1,37

METALLIC PROFILE NOT INCLUDED

Note: all value have been measured in standard weather conditions: 23°C/73°F with 50% relative humidity (DIN 50005/ISO 554)

Quantity, availability and prices on B2B Chiaravalli



PROFILE SF

MADE IN ITALY

Standard lengths 2 METERS

(on request we provide higher lengths)

Material: PE-UHMW High molecular weight polyethylene (p.m. over 1.000.000)

Color: green

Specific gravity: g/cm³ 0,945

Dynamic friction coefficient: 0.2 (P = 0.05 N/mm² - V = 0.6 m/s - T = 40°C)

Temperature range : -70°C ÷ 65°C

Linear thermal expansion: mm 2 every 10°C from the temperature of 20°C.

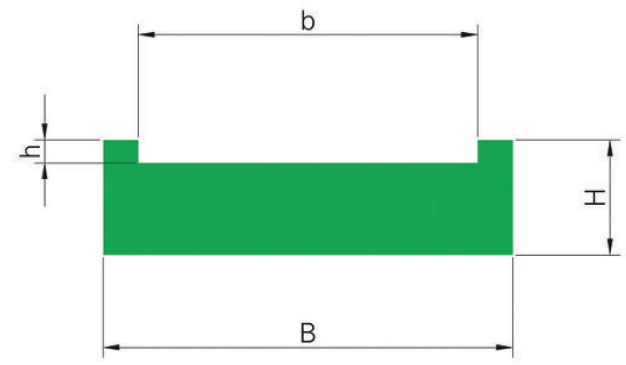
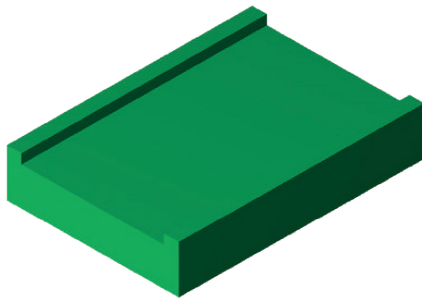

DESCRIPTION	ARTICLE CODE	REFERENCE BELT	B	H	b	h	WEIGHT
			mm	mm	mm	mm	Kg/piece
SF 5-16	GC 2 65 01 2	T5 16-AT5 16	25.0	10.0	17.0	1.8	0,59
SF 5-25	GC 2 65 02 2	T5 25-AT5 25	34.0	10.0	26.0	1.8	0,76
SF 5-32	GC 2 65 03 2	T5 32-AT5 32	41.0	10.0	33.0	1.8	0,89
SF 5-50	GC 2 65 04 2	T5 50-AT5 50	59.0	10.0	51.0	1.8	1,40
SF 10-16	GC 2 65 05 2	T10 16-AT10 16	25.0	15.0	17.0	3.8	0,88
SF 10-25	GC 2 65 06 2	T10 25-AT10 25	34.0	15.0	26.0	3.8	1,14
SF 10-32	GC 2 65 07 2	T10 32-AT10 32	41.0	15.0	33.0	3.8	1,34
SF 10-50	GC 2 65 08 2	T10 50-AT10 50	59.0	15.0	51.0	3.8	1,85
SF 10-75	GC 2 65 09 2	T10 75-AT10 75	84.0	15.0	76.0	3.8	2,57
SF 10-100	GC 2 65 10 2	T10 100-AT10 100	109.0	15.0	101.0	3.8	3,28
SF 20-25	GC 2 65 11 2	T20 25-AT20 25	34.0	20.0	26.0	7.0	1,52
SF 20-32	GC 2 65 12 2	T20 32-AT20 32	41.0	20.0	33.0	7.0	1,79
SF 20-50	GC 2 65 13 2	T20 50-AT20 50	59.0	20.0	51.0	7.0	2,47
SF 20-75	GC 2 65 14 2	T20 75-AT20 75	84.0	20.0	76.0	7.0	3,71
SF 20-100	GC 2 65 15 2	T20 100-AT20 100	109.0	20.0	101.0	7.0	4,94

Note: all value have been measured in standard weather conditions: 23°C/73°F with 50% relative humidity (DIN 50005/ISO 554)

Quantity, availability and prices on B2B Chiaravalli



PROFILE SFC

MADE IN ITALY

Standard lengths 2 METERS

(on request we provide higher lengths)

Material: PE-UHMW High molecular weight polyethylene (p.m. over 1.000.000)

Color: green

Specific gravity: g/cm³ 0,945

Dynamic friction coefficient: 0.2 (P = 0.05 N/mm² - V = 0.6 m/s - T = 40°C)

Temperature range : -70°C ÷ 65°C

Linear thermal expansion: mm 2 every 10°C from the temperature of 20°C.

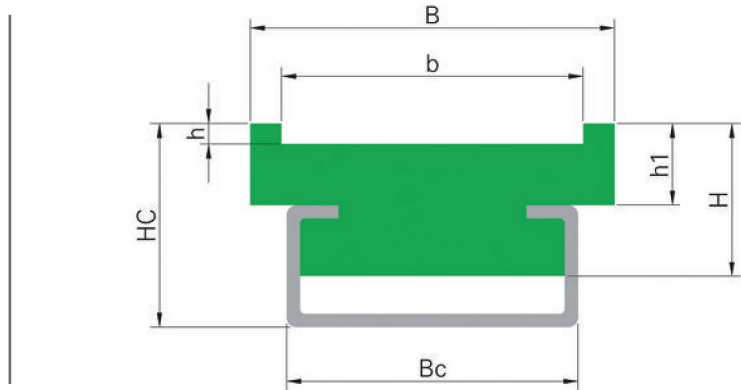
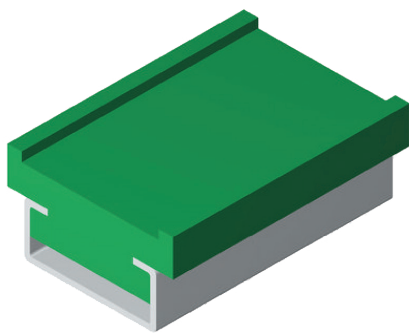

DESCRIPTION	ARTICLE CODE	REFERENCE BELT	B	H	BC	HC	h1	b	h	METALLIC PROFILE	WEIGHT
			mm	mm	mm	mm	mm	mm	mm		Kg/piece
SFC 5-16	GC 2 70 01 2	T5 16-AT5 16	25.0	15.0	28.0	19.0	7.0	17.0	1.8	C-5	0,88
SFC 5-25	GC 2 70 02 2	T5 25-AT5 25	34.0	15.0	28.0	19.0	7.0	26.0	1.8	C-5	1,14
SFC 5-32	GC 2 70 03 2	T5 32-AT5 32	41.0	20.0	38.0	25.0	7.0	33.0	1.8	C-9	1,79
SFC 5-50	GC 2 70 04 2	T5 50-AT5 50	59.0	20.0	38.0	25.0	7.0	51.0	1.8	C-9	2,79
SFC 10-16	GC 2 70 05 2	T10 16-AT10 16	25.0	17.0	28.0	21.0	9.0	17.0	3.8	C-5	1,18
SFC 10-25	GC 2 70 06 2	T10 25-AT10 25	34.0	17.0	28.0	21.0	9.0	26.0	3.8	C-5	1,52
SFC 10-32	GC 2 70 07 2	T10 32-AT10 32	41.0	22.0	38.0	27.0	9.0	33.0	3.8	C-9	2,23
SFC 10-50	GC 2 70 08 2	T10 50-AT10 50	59.0	22.0	38.0	27.0	9.0	51.0	3.8	C-9	3,09
SFC 10-75	GC 2 70 09 2	T10 75-AT10 75	84.0	22.0	38.0	27.0	9.0	76.0	3.8	C-9	4,63
SFC 10-100	GC 2 70 10 2	T10 100-AT10 100	109.0	22.0	38.0	27.0	9.0	101.0	3.8	C-9	6,18
SFC 20-25	GC 2 70 11 2	T20 25-AT20 25	34.0	20.0	28.0	24.0	12.0	26.0	7.0	C-5	1,52
SFC 20-32	GC 2 70 12 2	T20 32-AT20 32	41.0	25.0	38.0	30.0	12.0	33.0	7.0	C-9	2,23
SFC 20-50	GC 2 70 13 2	T20 50-AT20 50	59.0	25.0	38.0	30.0	12.0	51.0	7.0	C-9	3,09
SFC 20-75	GC 2 70 14 2	T20 75-AT20 75	84.0	25.0	38.0	30.0	12.0	76.0	7.0	C-9	4,63
SFC 20-100	GC 2 70 15 2	T20 100-AT20 100	109.0	25.0	38.0	30.0	12.0	101.0	7.0	C-9	6,18

METALLIC PROFILE NOT INCLUDED

Note: all value have been measured in standard weather conditions: 23°C/73°F with 50% relative humidity (DIN 50005/ISO 554)



PROFILE V

MADE IN ITALY

Standard lengths 2 METERS

(on request we provide higher lengths)

Material: PE-UHMW High molecular weight polyethylene (p.m. over 1.000.000)

Color: green

Specific gravity: g/cm³ 0,945

Dynamic friction coefficient: 0.2 (P = 0.05 N/mm² - V = 0.6 m/s - T = 40°C)

Temperature range : -70°C ÷ 65°C

Linear thermal expansion: mm 2 every 10°C from the temperature of 20°C.

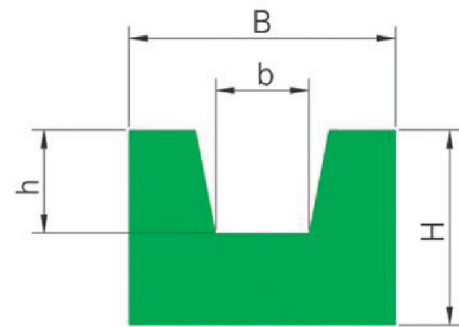
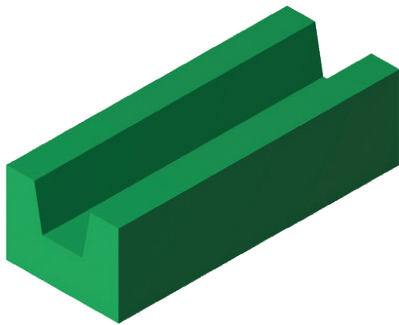

DESCRIPTION	ARTICLE CODE	TRAPEZOIDAL BELT	B	H	b	h	WEIGHT
			mm	mm	mm	mm	Kg/piece
V-01	GC 2 75 01 2	Z	20.0	10.0	6.5	3.0	0,34
V-03	GC 2 75 03 2	A	20.0	12.0	8.0	5.0	0,34
V-05	GC 2 75 05 2	SPB	25.0	12.0	9.5	5.0	0,53
V-07	GC 2 75 07 2	B	30.0	15.0	10.5	8.0	0,67
V-09	GC 2 75 09 2	C	35.0	20.0	13.5	11.0	1,00
V-11	GC 2 75 11 2	D	40.0	25.0	19.0	13.0	1,50

Note: all value have been measured in standard weather conditions: 23°C/73°F with 50% relative humidity (DIN 50005/ISO 554)



PROFILE VC

MADE IN ITALY

Standard lengths 2 METERS

(on request we provide higher lengths)

Material: PE-UHMW High molecular weight polyethylene (p.m. over 1.000.000)

Color: green

Specific gravity: g/cm³ 0,945

Dynamic friction coefficient: 0.2 (P = 0.05 N/mm² - V = 0.6 m/s - T = 40°C)

Temperature range : -70°C ÷ 65°C

Linear thermal expansion: mm 2 every 10°C from the temperature of 20°C.

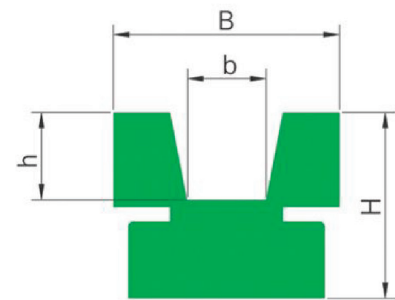
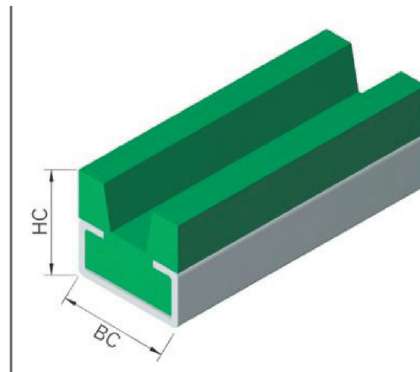
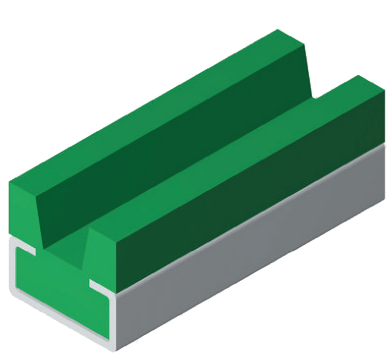

DESCRIPTION	ARTICLE CODE	TRAPEZOIDAL BELT	B	H	BH	HC	b	h	METALLIC PROFILE	WEIGHT
			mm	mm	mm	mm	mm	mm		Kg/piece
VC-02	GC 2 80 02 2	Z	20.0	15.0	20.0	17.0	6.5	3.0	C-3	0,28
VC-04	GC 2 80 04 2	A	20.0	15.0	20.0	17.0	8.0	5.0	C-3	0,27
VC-06	GC 2 80 06 2	SPB	25.0	20.0	28.0	24.0	9.5	5.0	C-5	0,60
VC-08	GC 2 80 08 2	B	30.0	20.0	28.0	24.0	10.5	8.0	C-5	0,72
VC-10	GC 2 80 10 2	C	35.0	25.0	38.0	32.0	13.5	11.0	C-9	1,14
VC-12	GC 2 80 12 2	D	40.0	25.0	38.0	35.0	19.0	13.0	C-9	1,12

METALLIC PROFILE NOT INCLUDED

Note: all value have been measured in standard weather conditions: 23°C/73°F with 50% relative humidity (DIN 50005/ISO 554)

Quantity, availability and prices on B2B Chiaravalli

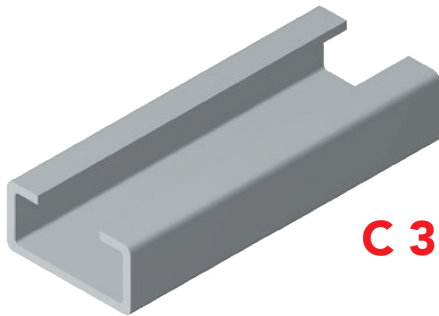
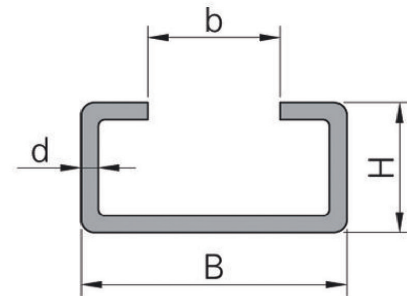

C 3 - 5 - 9 - 10 - 11
MADE IN ITALY

Material: galvanized steel FE
AISI 304 steel

C 3 - 5 - 9

DESCRIPTION	ARTICLE CODE	B	H	b	d	WEIGHT
GALVANIZED STEEL FE		mm	mm	mm	mm	Kg/piece
C-3 ZINCATO	GC 0 00 03 2	20.0	10.0	10.0	1.5	0,86
C-5 ZINCATO	GC 0 00 05 2	28.0	12.0	14.0	1.5	1,70
C-9 ZINCATO	GC 0 00 09 2	38.0	18.0	22.0	1.5	1,96
C-10 ZINCATO	GC 0 00 10 2	30.0	24.0	20.0	1.5	1,88
C-11 ZINCATO	GC 0 00 11 2	45.0	40.0	31.0	1.5	4,10

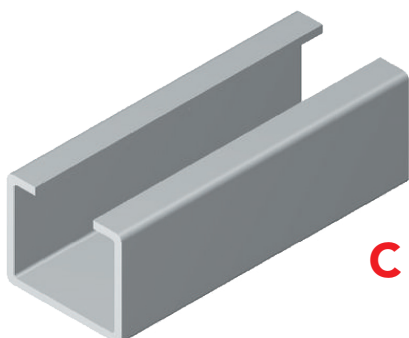
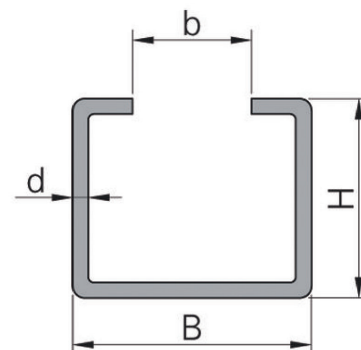
DESCRIPTION	ARTICLE CODE	B	H	b	d	WEIGHT
AISI 304 STEEL		mm	mm	mm	mm	Kg/piece
C-3 INOX	GC 0 10 03 2	20.0	10.0	10.0	1.5	0,86
C-5 INOX	GC 0 10 05 2	28.0	12.0	14.0	1.5	1,70
C-9 INOX	GC 0 10 09 2	38.0	18.0	22.0	1.5	1,96
C-10 INOX	GC 0 10 10 2	30.0	24.0	20.0	1.5	1,88
C-11 INOX	GC 0 10 11 2	45.0	40.0	31.0	1.5	4,10

C 10 - 11

Note: all value have been measured in standard weather conditions: 23°C/73°F with 50% relative humidity (DIN 50005/ISO 554)



STRAIGHT SPUR GEARS and RACKS

SPUR GEARS
WITH LATERAL HUB

page 4

SPUR GEARS
WITHOUT HUB

7

RACKS

9



SPUR GEARS AND RACKS

SPUR GEARS AND RACKS

SPUR GEARS
WITHOUT HUB



SPUR GEARS
WITH LATERAL HUB

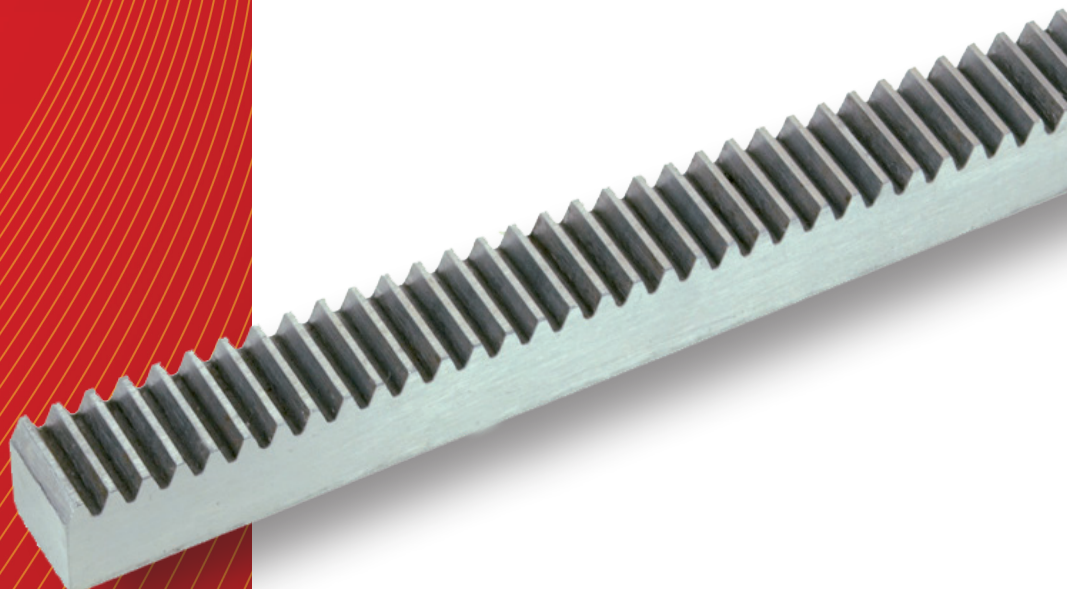

RACKS



STRAIGHT SPUR GEARS AND RACKS

Straight gears and racks are the classical components for mechanical transmission of rotary and transverse movements between moving parts of machines.

This explains why these components are so widespread and are used to such a large extent in various sectors of general mechanics such that in practice it is impossible to find a rigid type power transfer drive chain which does not adopt these basic components.

However, the needs of industry are extremely complex as regards the performance required from the gear and the rack and reflect the typical operating conditions in terms of precision or resistance of final use for which the gear and the rack are designed. This is why proposing a product intended to meet any need expressed by industrial experience would be unthinkable.

CHIARAVALLI GROUP SpA has made a basic choice with this aspect in mind, deciding to offer industry a broad range of gears and racks for general use, combined in a standardised series, which is characterised by excellent quality.

The gears and racks produced using standardised C40 steel are manufactured adopting modular sizes in accordance with a reference profile that complies with

DIN 3972

II and a full head radius.

This ensures complete engagement at the base of the tooth with an obvious increase in the bending resistance.

The internal specifications that define the geometry of the tooth prescribe a marked "K" profile for the side surface, with a strict limitation of the profile errors to negative deviations. This has a positive influence on the level of noise of the toothed pair, since the engaging impacts to the teeth head are reduced.

The systematic use of latest generation CNC gear hobbing machines, special hobs designed for very high cutting speeds and specifically developed processing technologies, enable a general precision to be assured in compliance with

DIN 3962

Standards and a degree of surface finish that is not readily achieved with operations using a hob gear cutting machine.

The working tolerance for tooth thickness has been chosen to comply with the "**cd 25**" **Coupling Category** in accordance

with **DIN 3967** Standards,

which defines the position and the size of the tolerance range and therefore the coupling gap between the gears.

A processing **tolerance equal to "js 8"** for the centre distance is recommended in compliance with

DIN 3964 Standards

for normal operating conditions, which if adopted, enables us to assure a minimum working coupling gap of adequate size, while at the same time limiting the value of the maximum gap. Similar considerations apply in the case of the gear-rack coupling, since the latter is manufactured adopting the same coupling category.

Our Technical Department is available and willing to recommend the most appropriate assembly tolerances to Customers who are interested, although we are also able to manufacture gears with coupling gaps that are larger or smaller compared with the standard value to meet specific needs.

We are able to manufacture our straight gears as illustrated in the catalogue with a lengthwise crowning of the teeth, at the request of customers. This solution is particularly useful if the user is unable to ensure a perfect alignment between the axes.

THE RANGE OF MACHINES USED, COMPRISING ALMOST ENTIRELY OF VERY MODERN MACHINES THAT HAVE CUTTING EDGE FEATURES AND DESIGN ENABLES OUR COMPANY TO PRODUCE GEARS BASED ON A DRAWING IN QUALITATIVE AT A VERY COMPETITIVE PRICE.

Our Technical Department is available to carry out a preliminary examination of any processing problems experienced by Customers and to prepare cost estimates.



WITH LATERAL HUB

Pressure angle: 20°

MATERIAL C 45 UNI 7845

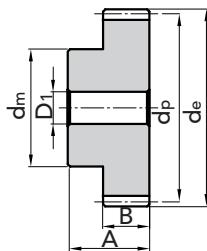

WIDTH BAND B for:

Module 1 = 15 mm

Module 1.5 = 17 mm

Module 2 = 20 mm

TOTAL WIDTH A for:

Module 1 = 25 mm

Module 1.5 = 30 mm

Module 2 = 35 mm

MODULE 1							MODULE 1,5					MODULE 2						
Z	P. NUMBER	d _e	d _p	d _m	ØD ₁	Kg	P. NUMBER	d _e	d _p	d _m	ØD ₁	Kg	P. NUMBER	d _e	d _p	d _m	ØD ₁	Kg
12	30110012	14	12	9	5	0,01	30115012	21,0	18,0	14	8	0,04	30120012	28	24	18	10	0,08
13	30110013	15	13	10	5	0,02	30115013	22,5	19,5	14	8	0,05	30120013	30	26	19	10	0,10
14	30110014	16	14	10	6	0,02	30115014	24,0	21,0	17	8	0,06	30120014	32	28	20	10	0,12
15	30110015	17	15	12	6	0,02	30115015	25,5	22,5	18	8	0,07	30120015	34	30	22	10	0,14
16	30110016	18	16	13	6	0,03	30115016	27,0	24,0	20	8	0,08	30120016	36	32	24	10	0,16
17	30110017	19	17	14	8	0,03	30115017	28,5	25,5	20	8	0,09	30120017	38	34	25	10	0,18
18	30110018	20	18	15	8	0,03	30115018	30,0	27,0	20	8	0,10	30120018	40	36	25	10	0,19
19	30110019	21	19	15	8	0,04	30115019	31,5	28,5	20	8	0,10	30120019	42	38	25	10	0,21
20	30110020	22	20	16	8	0,04	30115020	33,0	30,0	25	8	0,13	30120020	44	40	30	10	0,26
21	30110021	23	21	16	8	0,05	30115021	34,5	31,5	25	10	0,13	30120021	46	42	30	12	0,27
22	30110022	24	22	18	8	0,05	30115022	36,0	33,0	25	10	0,14	30120022	48	44	30	12	0,29
23	30110023	25	23	18	8	0,06	30115023	37,5	34,5	25	10	0,16	30120023	50	46	30	12	0,31
24	30110024	26	24	20	8	0,06	30115024	39,0	36,0	25	10	0,17	30120024	52	48	35	12	0,36
25	30110025	27	25	20	8	0,07	30115025	40,5	37,5	25	10	0,18	30120025	54	50	35	12	0,39
26	30110026	28	26	20	8	0,07	30115026	42,0	39,0	30	12	0,20	30120026	56	52	40	12	0,45
27	30110027	29	27	20	8	0,08	30115027	43,5	40,5	30	12	0,22	30120027	58	54	40	12	0,47
28	30110028	30	28	20	8	0,08	30115028	45,0	42,0	30	12	0,23	30120028	60	56	40	12	0,50
29	30110029	31	29	20	8	0,09	30115029	46,5	43,5	30	12	0,24	30120029	62	58	40	14	0,52
30	30110030	32	30	20	8	0,09	30115030	48,0	45,0	30	12	0,26	30120030	64	60	40	14	0,55
31	30110031	33	31	25	10	0,11	30115031	49,5	46,5	35	12	0,30	30120031	66	62	45	14	0,61
32	30110032	34	32	25	10	0,12	30115032	51,0	48,0	35	12	0,31	30120032	68	64	45	14	0,65
33	30110033	35	33	25	10	0,12	30115033	52,5	49,5	35	12	0,33	30120033	70	66	45	14	0,68
34	30110034	36	34	25	10	0,13	30115034	54,0	51,0	35	12	0,34	30120034	72	68	45	14	0,71
35	30110035	37	35	25	10	0,14	30115035	55,5	52,5	35	12	0,36	30120035	74	70	45	14	0,74
36	30110036	38	36	25	10	0,14	30115036	57,0	54,0	35	12	0,37	30120036	76	72	45	14	0,78
37	30110037	39	37	25	10	0,15	30115037	58,5	55,5	40	12	0,42	30120037	78	74	50	14	0,86
38	30110038	40	38	25	10	0,16	30115038	60,0	57,0	40	12	0,44	30120038	80	76	50	14	0,90
39	30110039	41	39	25	10	0,16	30115039	61,5	58,5	40	12	0,46	30120039	82	78	50	14	0,93
40	30110040	42	40	25	10	0,17	30115040	63,0	60,0	40	12	0,48	30120040	84	80	50	14	0,97
41	30110041	43	41	30	10	0,19	30115041	64,5	61,5	50	14	0,50	30120041	86	82	60	16	1,05
42	30110042	44	42	30	10	0,20	30115042	66,0	63,0	50	14	0,59	30120042	88	84	60	16	1,09
43	30110043	45	43	30	10	0,21	30115043	67,5	64,5	50	14	0,61	30120043	90	86	60	16	1,13
44	30110044	46	44	30	10	0,22	30115044	69,0	66,0	50	14	0,63	30120044	92	88	60	16	1,23
45	30110045	47	45	30	10	0,23	30115045	70,5	67,5	50	14	0,65	30120045	94	90	60	16	1,27
46	30110046	48	46	30	10	0,23	30115046	72,0	69,0	50	14	0,66	30120046	96	92	60	16	1,31
47	30110047	49	47	30	10	0,24	30115047	73,5	70,5	50	14	0,70	30120047	98	94	60	16	1,48
48	30110048	50	48	30	10	0,35	30115048	75,0	72,0	50	14	0,70	30120048	100	96	70	16	1,53
49	30110049	51	49	30	10	0,36	30115049	76,5	73,5	50	14	0,73	30120049	102	98	70	16	1,57
50	30110050	52	50	30	12	0,26	30115050	78,0	75,0	50	14	0,76	30120050	104	100	70	16	1,62
51	30110051	53	51	40	12	0,32	30115051	79,5	76,5	60	15	0,86	30120051	106	102	70	20	1,67
52	30110052	54	52	40	12	0,33	30115052	81,0	78,0	60	15	0,89	30120052	108	104	70	20	1,72
53	30110053	55	53	40	12	0,33	30115053	82,5	79,5	60	15	0,91	30120053	110	106	70	20	1,78
54	30110054	56	54	40	12	0,34	30115054	84,0	81,0	60	15	0,94	30120054	112	108	70	20	1,83
55	30110055	57	55	40	12	0,36	30115055	85,5	82,5	60	15	0,96	30120055	114	110	70	20	1,88
56	30110056	58	56	40	12	0,37	30115056	87,0	84,0	60	15	0,98	30120056	116	112	70	20	1,94
57	30110057	59	57	40	12	0,38	30115057	88,5	85,5	60	15	1,00	30120057	118	114	70	20	1,99
58	30110058	60	58	40	12	0,39	30115058	90,0	87,0	60	15	1,03	30120058	120	116	70	20	2,05
59	30110059	61	59	40	12	0,40	30115059	91,5	88,5	60	15	1,06	30120059	122	118	70	20	2,11
60	30110060	62	60	40	12	0,41	30115060	93,0	90,0	60	15	1,09	30120060	124	120	70	20	2,16
61	30110061	63	61	50	12	0,47	30115061	94,5	91,5	70	20	1,22	30120061	126	122	80	20	2,36
62	30110062	64	62	50	12	0,49	30115062	96,0	93,0	70	20	1,25	30120062	128	124	80	20	2,42
63	30110063	65	63	50	12	0,50	30115063	97,5	94,5	70	20	1,28	30120063	130	126	80	20	2,48
64	30110064	66	64	50	12	0,51	30115064	99,0	96,0	70	20	1,31	30120064	132	128	80	20	2,55
65	30110065	67	65	50	12	0,52	30115065	100,5	97,5	70	20	1,34	30120065	134	130	80	20	2,61
66	30110066	68	66	50	12	0,53	30115066	102,0	99,0	70	20	1,37	30120066	136	132	80	20	2,67
67	30110067	69	67	50	12	0,55	30115067	103,5	100,5	70	20	1,40	30120067	138	134	80	20	2,74
68	30110068	70	68	50	12	0,56	30115068	105,0	102,0	70	20	1,43	30120068	140	136	80	20	2,81
69	30110069	71	69	50	12	0,57	30115069	106,5	103,5	70	20	1,46	30120069	142	138	80	20	2,87
70	30110070	72	70	50	12	0,58	30115070	108,0	105,0	70	20	1,50	30120070	144	140	80	20	2,94

CAD drawings available on our site
www.chiaravalli.com

Quantity, availability and prices
 on B2B Chiaravalli



STRAIGHT SPUR GEARS AND RACKS

WITH LATERAL HUB

Pressure angle: 20°

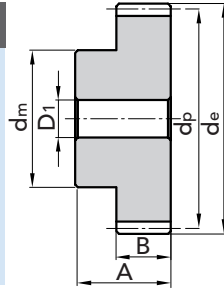

WIDTH BAND B for:

- Module **2.5** = 25 mm
- Module **3** = 30 mm
- Module **4** = 40 mm

TOTAL WIDTH A for:

- Module **2.5** = 40 mm
- Module **3** = 50 mm
- Module **4** = 60 mm

MODULE 2,5

Z	P. NUMBER	d _e	d _p	d _m	ØD ₁	Kg
12	30125012	35,0	30,0	22	10	0,17
13	30125013	37,5	32,5	25	10	0,21
14	30125014	40,0	35,0	28	10	0,25
15	30125015	42,5	37,5	30	10	0,30
16	30125016	45,0	40,0	32	12	0,33
17	30125017	47,5	42,5	35	12	0,38
18	30125018	50,0	45,0	35	12	0,42
19	30125019	52,5	47,5	35	12	0,45
20	30125020	55,0	50,0	40	14	0,54
21	30125021	57,5	52,5	40	14	0,56
22	30125022	60,0	55,0	45	14	0,66
23	30125023	62,5	57,5	45	14	0,70
24	30125024	65,0	60,0	45	14	0,74
25	30125025	67,5	62,5	50	14	0,85
26	30125026	70,0	65,0	50	14	0,90
27	30125027	72,5	67,5	50	14	0,95
28	30125028	75,0	70,0	50	14	1,00
29	30125029	77,5	72,5	50	14	1,06
30	30125030	80,0	75,0	55	16	1,18
31	30125031	82,5	77,5	55	16	1,22
32	30125032	85,0	80,0	55	16	1,28
33	30125033	87,5	82,5	55	16	1,34
34	30125034	90,0	85,0	55	16	1,41
35	30125035	92,5	87,5	60	16	1,54
36	30125036	95,0	90,0	60	16	1,61
37	30125037	97,5	92,5	60	16	1,68
38	30125038	100,0	95,0	60	16	1,75
39	30125039	102,5	97,5	60	16	1,83
40	30125040	105,0	100,0	70	20	2,06
41	30125041	107,5	102,5	70	20	2,14
42	30125042	110,0	105,0	70	20	2,22
43	30125043	112,5	107,5	70	20	2,30
44	30125044	115,0	110,0	70	20	2,38
45	30125045	117,5	112,5	70	20	2,47
46	30125046	120,0	115,0	70	20	2,52
47	30125047	122,5	117,5	80	20	2,80
48	30125048	125,0	120,0	80	20	2,88
49	30125049	127,5	122,5	80	20	2,98
50	30125050	130,0	125,0	80	20	3,07
51	30125051	132,5	127,5	90	20	3,17
52	30125052	135,0	130,0	90	20	3,48
53	30125053	137,5	132,5	90	20	3,58
54	30125054	140,0	135,0	90	20	3,68
55	30125055	142,5	137,5	90	20	3,78
56	30125056	145,0	140,0	100	20	4,13
57	30125057	147,5	142,5	100	20	4,23
58	30125058	150,0	145,0	100	20	4,34
59	30125059	152,5	147,5	100	20	4,46
60	30125060	155,0	150,0	100	20	4,57

MODULE 3

P. NUMBER	d _e	d _p	d _m	ØD ₁	Kg
30130012	42	36	25	12	0,28
30130013	45	39	25	12	0,34
30130014	48	42	30	12	0,41
30130015	51	45	35	12	0,47
30130016	54	48	38	15	0,54
30130017	57	51	42	15	0,63
30130018	60	54	45	15	0,72
30130019	63	57	45	15	0,78
30130020	66	60	45	15	0,84
30130021	69	63	45	15	0,89
30130022	72	66	50	15	1,02
30130023	75	69	50	15	1,10
30130024	78	72	50	16	1,18
30130025	81	75	60	16	1,39
30130026	84	78	60	16	1,48
30130027	87	81	60	16	1,56
30130028	90	84	60	16	1,66
30130029	93	87	60	16	1,75
30130030	96	90	60	16	1,85
30130031	99	93	70	20	1,95
30130032	102	96	70	20	2,21
30130033	105	99	70	20	2,32
30130034	108	102	70	20	2,43
30130035	111	105	70	20	2,55
30130036	114	108	70	20	2,62
30130037	117	111	80	20	2,74
30130038	120	114	80	20	3,05
30130039	123	117	80	20	3,18
30130040	126	120	80	20	3,31
30130041	129	123	90	20	3,44
30130042	132	126	90	20	3,58
30130043	135	129	90	20	3,72
30130044	138	132	90	20	4,07
30130045	141	135	90	20	4,22
30130046	144	138	90	20	4,37
30130047	147	141	90	20	4,76
30130048	150	144	100	20	4,92

MODULE 4

P. NUMBER	d _e	d _p	d _m	ØD ₁	Kg
30140012	56	48	35	14	0,63
30140013	60	52	40	14	0,78
30140014	64	56	45	14	0,93
30140015	68	60	45	14	1,05
30140016	72	64	50	15	1,20
30140017	76	68	50	15	1,33
30140018	80	72	50	15	1,47
30140019	84	76	60	15	1,75
30140020	88	80	60	15	1,90
30140021	92	84	70	20	2,22
30140022	96	88	70	20	2,39
30140023	100	92	75	20	2,60
30140024	104	96	75	20	2,79
30140025	108	100	75	20	2,98
30140026	112	104	75	20	3,18
30140027	116	108	75	20	3,39
30140028	120	112	75	20	3,60
30140029	124	116	75	20	3,83
30140030	128	120	75	20	4,06
30140031	132	124	80	20	4,39
30140032	136	128	80	20	4,64
30140033	140	132	80	20	4,90
30140034	144	136	80	20	5,16
30140035	148	140	80	20	5,43
30140036	152	144	80	20	5,63

MATERIAL C 45 UNI 7845



CAD drawings available on our site
www.chiaravalli.com

Quantity, availability and prices
 on B2B Chiaravalli



WITH LATERAL HUB

Pressure angle: 20°

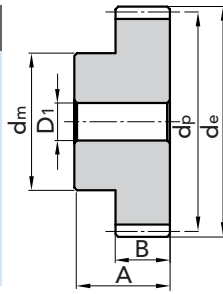
WIDTH BAND **B** for:

Module **5** = 50 mm
 Module **6** = 60 mm
 Module **8** = 80 mm

TOTAL WIDTH **A** for:

Module **5** = 75 mm
 Module **6** = 80 mm
 Module **8** = 110 mm

MODULE 5							MODULE 6					MODULE 8						
Z	P. NUMBER	d _e	d _p	d _m	ØD ₁	Kg	P. NUMBER	d _e	d _p	d _m	ØD ₁	Kg	P. NUMBER	d _e	d _p	d _m	ØD ₁	Kg
12	30150012	70	60	45	16	1,21	30160012	84	72	54	16	1,98						
13	30150013	75	65	50	16	1,47	30160013	90	78	60	16	2,38						
14	30150014	80	70	55	20	1,76												
15	30150015	85	75	60	20	2,07	30160015	102	90	70	20	3,29	30180015	136	120	90	25	8,20
16	30150016	90	80	65	20	2,40	30160016	108	96	75	20	3,80						
17	30150017	95	85	70	20	2,75												
18	30150018	100	90	70	20	3,02	30160018	120	108	80	20	4,76	30180018	160	144	100	25	11,7
19	30150019	105	95	70	20	3,30												
20	30150020	110	100	80	20	3,83	30160020	132	120	90	20	5,99	30180020	176	160	120	30	14,6
21	30150021	115	105	80	20	4,15												
22	30150022	120	110	80	25	4,48												
23	30150023	125	115	90	25	5,08												
24	30150024	130	120	90	25	5,44	30160024	156	144	110	25	8,70	30180024	208	192	150	30	21,7
25	30150025	135	125	90	25	5,82	30160025	162	150	110	25	9,33	30180025	216	200	150	30	23,3
26	30150026	140	130	100	25	6,50												
27	30150027	145	135	100	25	6,91												
28	30150028	150	140	100	25	7,22							30180028	240	224	170	30	29,5
29	30150029	155	145	100	25	7,98												
30	30150030	160	150	100	25	8,44							30180030	256	240	190	30	34,4
31																		
32																		
33																		
34																		
35																		
36																		
37																		
38																		
39																		
40																		
41																		
42																		
43																		
44																		
45																		
46																		
47																		
48																		
49																		
50																		
51																		
52																		
53																		
54																		
55																		
56																		
57																		
58																		
59																		
60																		

MATERIAL **C 45 UNI 7845**

CAD drawings available on our site
www.chiaravalli.com

Quantity, availability and prices
 on B2B Chiaravalli





STRAIGHT SPUR GEARS AND RACKS

WITHOUT HUB LATERAL

Pressure angle: 20°

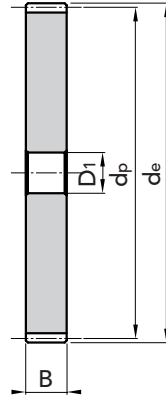

WIDTH BAND B for:

- Module 1 = 15 mm
- Module 1.5 = 17 mm
- Module 2 = 20 mm
- Module 2.5 = 25 mm

STRAIGHT SPUR GEARS AND RACKS

Z	MODULE 1					MODULE 1.5					MODULE 2					MODUE 2.5					
	P. NUMBER	d _e	d _p	ØD ₁	Kg	P. NUMBER	d _e	d _p	ØD ₁	Kg	P. NUMBER	d _e	d _p	ØD ₁	Kg	P. NUMBER	d _e	d _p	ØD ₁	Kg	
55																					
57																					
60																					
65																					
70																	30225065	167,5	162,5	20	3,99
72	30210072	74	72	12	0,46	30215072	111	108	20	1,19	30220072	148	144	20	2,50	30225072	185	180	20	4,91	
75	30210075	77	75	12	0,51	30215075	115,5	112,5	20	1,30	30220075	154	150	20	2,61	30225075	192,5	187,5	20	5,33	
76	30210076	78	76	12	0,52	30215076	117	114	20	1,33	30220076	156	152	20	2,79	30225076	195	190	20	5,48	
80	30210080	82	80	12	0,58	30215080	123	120	20	1,48	30220080	164	160	20	3,09	30225080	205	200	25	6,04	
85	30210085	87	85	12	0,65	30215085	130,5	127,5	20	1,67	30220085	174	170	20	3,50	30225085	217,5	212,5	25	6,84	
90	30210090	92	90	12	0,73	30215090	138	135	20	1,78	30220090	184	180	20	3,93	30225090	230	225	25	7,68	
95	30210095	97	95	12	0,82	30215095	145,5	142,5	20	2,09	30220095	194	190	20	4,39	30225095	242,5	237,5	25	8,57	
100	30210100	102	100	12	0,91	30215100	153	150	20	2,32	30220100	204	200	20	4,87	30225100	255	250	25	9,51	
110	30210110	112	110	12	1,10	30215110	168	165	20	2,82	30220110	224	220	20	5,90	30225110	280	275	25	11,53	
114	30210114	116	114	12	1,19	30215114	174	171	20	3,03	30220114	232	228	20	6,34	30225114	290	285	25	12,39	
120	30210120	122	120	12	1,32	30215120	183	180	20	3,36	30220120	244	240	20	7,03	30225120	305	300	25	13,74	
127	30210127	129	127	12	1,47	30215127	193,5	190,5	20	3,77	30220127	258	254	20	7,89	30225127	322,5	317,5	25	15,40	

MATERIAL C 45 UNI 7845



CAD drawings available on our site
www.chiaravalli.com

Quantity, availability and prices
 on B2B Chiaravalli



WITHOUT HUB LATERAL

Pressure angle: 20°

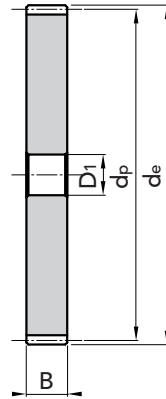
WIDTH BAND **B** for:

Module **3** = 30 mm
 Module **4** = 40 mm
 Module **5** = 50 mm
 Module **6** = 60 mm

Z	MODULE 3					MODULE 4					MODULE 5					MODULE 6				
	P. NUMBER	d _e	d _p	ØD ₁	Kg	P. NUMBER	d _e	d _p	ØD ₁	Kg	P. NUMBER	d _e	d _p	ØD ₁	Kg	P. NUMBER	d _e	d _p	ØD ₁	Kg
28																30260028	180	168	25	10,0
30																30260030	192	180	25	11,55
32											30250032	170	160	25	7,62	30260032	204	192	25	13,22
35											30250035	185	175	25	9,16	30260035	222	210	25	15,79
38						30240038	160	152	25	5,20	30250038	200	190	30	10,84	30260038	240	228	25	18,74
40						30240040	168	160	25	6,11	30250040	210	200	30	12,04	30260040	252	240	25	20,75
45						30240045	188	180	25	7,68	30250045	235	225	30	15,30					
48						30240048	200	192	25	8,87	30250048	250	240	30	17,44					
50	30230050	156	150	25	4,06	30240050	208	200	25	9,65	30250050	260	250	30	18,69					
52	30230052	162	156	25	4,40	30240052	216	208	25	10,45	30250052	270	260	30	20,43					
55	30230055	171	165	25	4,93	30240055	228	220	25	11,01	30250055	285	275	30	22,89					
57	30230057	177	171	25	5,30	30240057	236	228	25	12,59	30250057	295	285	30	24,62					
60	30230060	186	180	25	5,89	30240060	248	240	25	13,97	30250060	310	300	30	27,31					
65	30230065	201	195	25	6,92	30240065	268	260	25	16,43	30250065	335	325	30	32,12					
70	30230070	216	210	25	8,00	30240070	288	280	25	19,09	30250070	360	350	30	37,31					
72	30230072	222	216	25	8,47															
75	30230075	231	225	25	9,21	30240075	308	300	25	21,94	30250075	385	375	30	42,88					
76	30230076	234	228	25	9,46	30240076	312	304	25	22,47	30250076	390	380	30	44,04					
80	30230080	246	240	25	10,49	30240080	328	320	25	24,83	30250080	410	400	30	48,84					
85	30230085	261	255	25	11,76	30240085	348	340	25	28,18	30250085	435	425	30	55,19					
90	30230090	276	270	25	13,82	30240090	368	360	25	31,62	30250090	460	450	30	61,92					
95	30230095	291	285	25	14,86	30240095	388	380	25	35,26	30250095	485	475	30	69,03					
100	30230100	306	300	25	16,48	30240100	408	400	25	39,11	30250100	510	500	30	76,53					
110	30230110	336	320	25	19,97	30240110	448	440	25	47,38	30250110	560	550	30	92,69					
114	30230114	348	342	25	21,40	30240114	464	456	25	50,91	30250114	580	570	30	99,59					
120	30230120	366	360	25	23,74															
127	30230127	387	381	25	26,61															

MATERIAL **C 45 UNI 7845**

CAD drawings available on our site
www.chiaravalli.com

Quantity, availability and prices
 on B2B Chiaravalli





Tolerance on the pitch: = fpt
 from M=1 up to M=3 = ± 0,028
 from M=4 up to M=10 = ± 0,040

Tolerance on the sum of the wheelbases on 100 mm = ± 0,08

Quality class 9 as per norm
DIN 3962/63/67

Pressure angle 20°

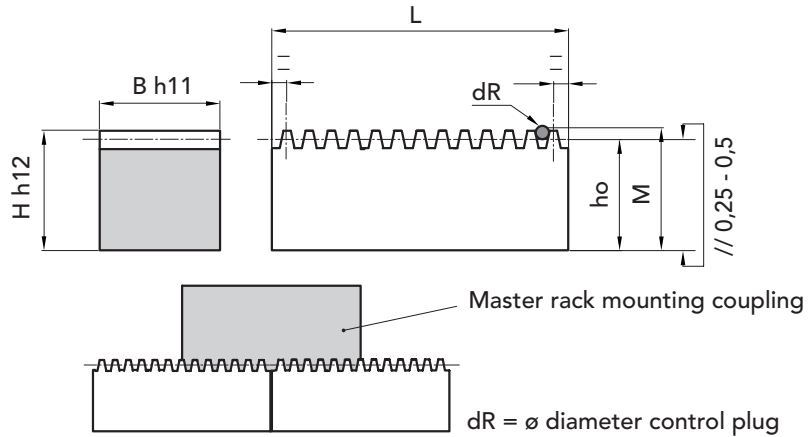

RACKS INSTRUCTIONS FOR CONTINUOUS MOUNTING

5

M	B h11	H h12	dR	ho	M	M - ho	L= real lenght of the rack x continuous mounting			
1	15 ⁰ _{-0,110}	15 ⁰ _{-0,180}	2	14	15,71 ⁻⁰ _{-0,35}	1,71	502,1 ± 0,3	1001,6 ± 0,3	2000,4 ± 0,3	2999,3 ± 0,3
1,5	17 ⁰ _{-0,110}	17 ⁰ _{-0,180}	3	15,5	18,09 ⁻⁰ _{-0,35}	2,59	503,6 ± 0,3	1003,1 ± 0,3	2002,0 ± 0,3	3000,8 ± 0,3
2	20 ⁰ _{-0,130}	20 ⁰ _{-0,210}	4	18	21,43 ⁻⁰ _{-0,35}	3,43	502,1 ± 0,3	1004,6 ± 0,3	2003,6 ± 0,3	3002,4 ± 0,3
2,5	25 ⁰ _{-0,130}	25 ⁰ _{-0,210}	5	22,5	26,81 ⁻⁰ _{-0,40}	4,31	502,1 ± 0,3	1004,6 ± 0,3	2001,8 ± 0,3	2999,1 ± 0,3
3	30 ⁰ _{-0,130}	30 ⁰ _{-0,210}	6	27	32,2 ⁻⁰ _{-0,40}	5,2	508,3 ± 0,3	1007,7 ± 0,3	2006,4 ± 0,3	3005,4 ± 0,3
4	30 ⁰ _{-0,130}	30 ⁰ _{-0,210}	8	26	32,92 ⁻⁰ _{-0,40}	6,92	502,1 ± 0,3	1004,6 ± 0,3	2009,7 ± 0,3	3002,3 ± 0,3
4	40 ⁰ _{-0,160}	40 ⁰ _{-0,250}	8	36	42,92 ⁻⁰ _{-0,40}	6,92	502,1 ± 0,3	1004,6 ± 0,3	2009,7 ± 0,3	3002,3 ± 0,3
5	50 ⁰ _{-0,160}	50 ⁰ _{-0,250}	10	45	53,66 ⁻⁰ _{-0,40}	8,66	502,1 ± 0,3	1004,6 ± 0,3	2009,7 ± 0,3	2999,1 ± 0,3
6	60 ⁰ _{-0,190}	60 ⁰ _{-0,300}	12	54	64,6 ⁻⁰ _{-0,40}	10,6	508,3 ± 0,3	1017,0 ± 0,3	2016,0 ± 0,3	3014,8 ± 0,3
8	80 ⁰ _{-0,190}	80 ⁰ _{-0,300}	14	72	82,2 ⁻⁰ _{-0,40}	10,2	-	-	2035,3 ± 0,3	-
10	80 ⁰ _{-0,190}	80 ⁰ _{-0,300}	18	70	83,74 ⁻⁰ _{-0,40}	13,74	-	-	2009,7 ± 0,3	-

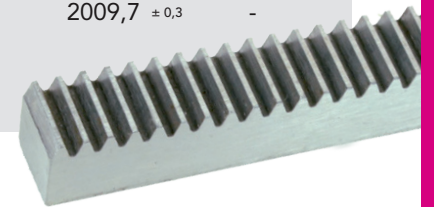

Racks for gates with buttonhole, for continuous mounting and zinc-plated, including screws, washers and bushes.

M	A x B	L	
		cod. 1000 mm	cod. 2000 mm
4	30 x 12	30900100	30900200

CONTINUOUS MOUNTING

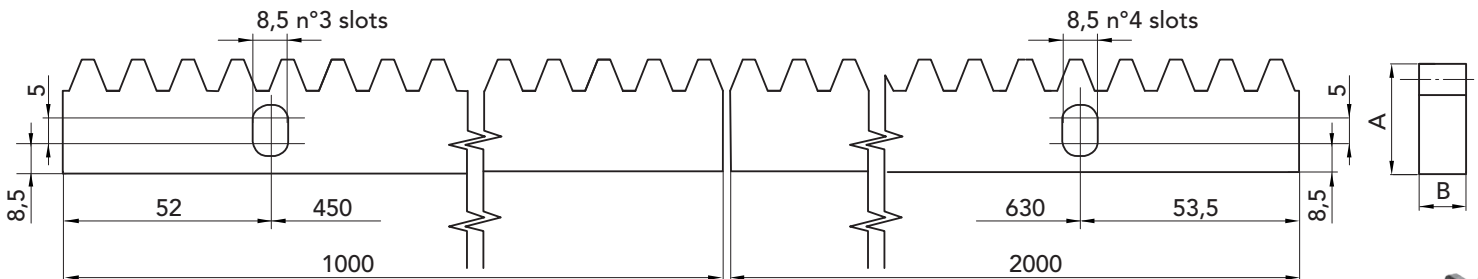

MATERIAL **C 40**
NORMALIZE

CAD drawings available on our site
www.chiaravalli.com

Quantity, availability and prices
 on B2B Chiaravalli

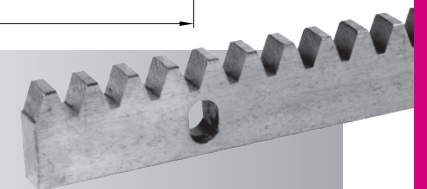



Pressure angle: 20°

All the racks provided by Chiaravalli Group SpA are realized for continuous mounting.

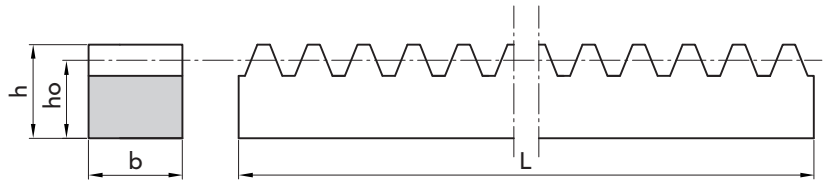

DIMENSIONS b x h

M	PART NUMBER	b	h	ho	L	Kg
1	30910050	15	15	14	500	0,82
	30910100				1000	1,64
	30910200				2000	3,20
	30910300				3000	4,80
1,5	30915050	17	17	15,5	500	1,00
	30915100				1000	2,05
	30915200				2000	4,00
	30915300				3000	6,00
2	30920050	20	20	18	500	1,41
	30920100				1000	2,75
	30920200				2000	5,50
	30920300				3000	8,20
2,5	30925050	25	25	22,5	500	2,10
	30925100				1000	4,50
	30925200				2000	9,00
	30925300				3000	13,40
3	30930050	30	30	27	500	3,10
	30930100				1000	6,50
	30930200				2000	13,00
	30930300				3000	19,40
4	30939050	30	30	26	500	3,05
	30939100				1000	6,10
	30939200				2000	12,50
4	30940050	40	40	36	500	5,50
	30940100				1000	11,00
	30940200				2000	23,00
	30940300				3000	34,00
5	30950050	50	50	45	500	8,30
	30950100				1000	17,50
	30950200				2000	35,00
	30950300				3000	52,40
6	30960050	60	60	54	500	12,65
	30960100				1000	25,50
	30960200				2000	51,00
	30960300				3000	76,40
8	30980200	80	80	72	2000	90,00
10	30999200	80	80	70	2000	87,90

MATERIAL **C 40**
NORMALIZE

CAD drawings available on our site
www.chiaravalli.com

Quantity, availability and prices
on B2B Chiaravalli





BEVEL GEARS

STANDARD EXECUTION

page 5

SPECIALE CH EXECUTION

GLEASON SYSTEM

9

SPIRALS

16

SPECIAL PRODUCTIONS

ON REQUEST

19



BEVEL GEARS

BEVEL GEARS

BEVEL GEAR WITH STRAIGHT TEETH
SPECIAL CH EXECUTION
GLEASON SYSTEM



SPIRALS BEVEL GEARS



BEVEL GEAR WITH STRAIGHT TEETH
STANDARD EXECUTION



SPIRALS BEVEL GEARS
GLEASON SYSTEM



The range of bevel gear showed in the catalogue is a selection structured according to transmission module and ratio, which is designed to meet the needs of general plant engineering and general mechanics to transmit motion among concurrent axes.

As such the range does not claim to guarantee particularly heavyduty performance or to cater for ratio ranges that extend to cover every need.

The external configuration of the bevel gear complies with the sizing criteria as established by the

DIN 3971 Standards,

while the tooth geometry, corrected by displacing the profiles and by varying the taper, is a specific solution exclusive to CHIARAVALLI GROUP SpA.

This solution, provides special advantages since:

- the coupling conditions between the pinion and the ring gear are improved;
- a smoother motion transmission is assured;
- tooth resistance is increased;
- the undercut effect on the pinion is avoided, even in the case of high transmission ratios and pinions with a limited number of teeth.

Since these refer to a selection of gears intended to be used in a broad range of applications, CHIARAVALLI GROUP SpA, continuing a tradition that has now become firmly established, has defined a standardised tolerance category for the processing of the Company's range of bevel gear, which means that there is a controlled gearing gap between the wheels.

The requirements detailed in the

DIN 3967 Standards

adapted to the virtual teeth profile of the bevel gear and the recommendations of the

DIN 3964 Standards

to calculate the corresponding axial displacements for the assembly distances have been used for this purpose.

We are therefore in a position to provide the end user precise information regarding the tolerances to be adopted to define shaving adjustments to a given clearance, in accordance with the values detailed in the dimensional tables.

All the bevel gears manufactured by CHIARAVALLI GROUP SpA will be produced in accordance with the profile envelope procedure on modern gear cutting machines, which enables CHIARAVALLI GROUP SpA to ensure a satisfactory quality level thanks to the systematic checking of processing tolerances.

For this technological sector too, the equipment and the range of machines available to CHIARAVALLI GROUP SpA enables the Company to produce bevel gears based on a drawing and in accordance with the Customer's specifications.





BEVEL GEARS WITH STRAIGHT TEETH

BEVEL GEARS WITH STRAIGHT TEETH





BEVEL GEAR WITH STRAIGHT TEETH norm DIN 3967

5

RATIO 1:1

Pressure angle: 20°
with normal axes in compliance to
UNI 6588

Teeth according to DIN 3967

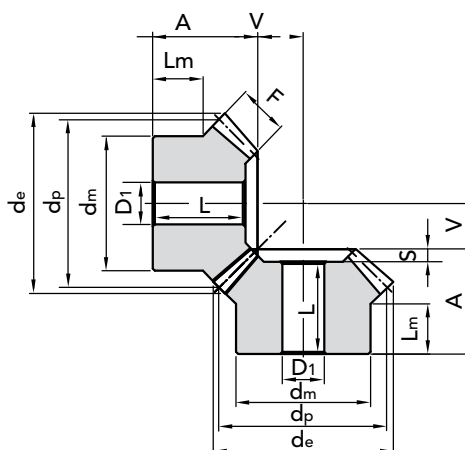

M	Z	PART NUMBER	d_p	d_e	F	A	d_m	D_1	L	V	S	L_m	Kg
1.5	16	35151116	24,0	26,12	6	18,9	20,3	8	-	7,10	-	12	0,03
	20	32151120	30,0	32,12	10	20	22	10	18	7,40	2	8,5	0,05
	25	32151125	37,5	39,62	10	23	28	10	21	11,09	2	12	0,10
	30	32151130	45,0	47,12	12	25	30	12	22,5	13,35	2,5	12	0,15
2	16	35201116	32,0	34,83	8	23,5	25,3	8	-	9,50	-	14	0,06
	20	32201120	40,0	42,83	12	25	32	10	22	10,78	3	11,7	0,14
	25	32201125	50,0	52,82	14	28	40	12	25	14,28	3	12,3	0,25
	30	32201130	60,0	62,83	16	30	50	12	27	17,78	3	12,8	0,41
2.5	16	35251116	40,0	43,53	10	28,1	30,3	12	-	11,90	-	15	0,13
	20	32251120	50,0	53,53	12	30,5	40	12	27	15,43	3,5	16	0,27
	25	32251125	62,5	66	15	33,5	50	15	30	19,48	3,5	16	0,47
	30	32251130	75,0	78,53	18	35,5	55	15	32	23,63	3,5	16	0,69
3	16	35301116	48,0	52,25	12	31,7	40,3	12	-	14,30	-	18	0,24
	20	32301120	60,0	64,24	18	35	45	15	31	16,00	4	13,6	0,41
	25	32301125	75,0	79,24	20	38	55	15	34	22,00	4	16	0,72
	30	32301130	90,0	94,24	22	40	60	20	36	28,00	4	17	0,99
3.5	16	35351116	56,0	60,95	14	36,4	45,3	16	-	16,60	-	20	0,38
	20	32351120	70,0	74,95	22	40,5	55	15	36	18,13	4,5	16,1	0,68
	25	32351125	87,5	92,45	26	43,5	65	20	39	23,97	4,5	18	1,10
	30	32351130	105,0	109,95	30	48	70	20	43,5	30,02	4,5	19	1,61
4	16	35401116	64,0	69,65	15	44,3	50,3	16	-	19,70	-	25	0,52
	20	32401120	80,0	85,65	25	43	60	18	38	20,74	5	18	0,90
	25	32401125	100,0	105,65	28	45	70	20	40	28,50	5	18	1,45
	30	32401130	120,0	125,65	32	48	80	20	43	35,67	5	16	2,66
4.5	16	35451116	72,0	78,38	17,5	46,3	55,3	20	-	21,70	-	25	0,73
	20	32451120	90,0	96,38	28	48	65	20	42	23,41	6	18	1,25
	25	32451125	112,5	118,8	32	50	75	20	44	31,76	6	18	2,04
	30	32451130	135,0	141,38	35	53	90	20	47	40,82	6	17	3,24
5	16	35501116	80,0	87,07	18	48,9	60,3	20	-	25,10	-	25	0,94
	20	32501120	100,0	107,07	30	50,5	70	20	44	26,86	6,5	18,5	1,61
	25	32501125	125,0	132,07	34	53,5	90	20	47	36,36	6,5	18	2,94
	30	32501130	150,0	157,07	38	56,5	110	20	50	45,97	6,5	18	4,46

MATERIAL C 45 UNI 7847

CAD drawings available on our site
www.chiaravalli.com

Quantity, availability and prices
on B2B Chiaravalli



BEVEL GEAR WITH STRAIGHT TEETH RATIO 1:1

RATIO 1:2

Pressure angle: 20°
with normal axes in compliance to
UNI 6588

Teeth according to DIN 3967

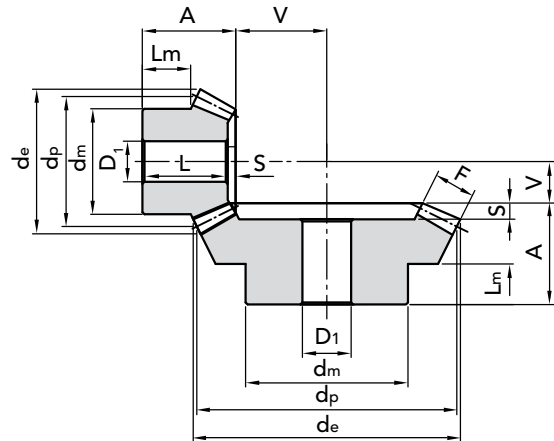

M	Z	PART NUMBER	d_p	d_e	F	A	d_m	D_1	L	V	S	L_m	Kg
1,5	16	32151216	24,0	26,68	8	19,5	21	10	18	16,33	1,5	11,3	0,04
	32	33151232	48,0	49,34	8	20	32	12	17	7,45	3	10	0,14
2	16	32201216	32,0	35,57	10	23	26	10	21	22,41	2	11,9	0,09
	32	33201232	64,0	65,78	10	25	40	12	21	10,21	4	10	0,14
2,5	16	32251216	40,0	44,47	12	27,5	34	12	25	28,38	2,5	14,4	0,16
	32	33251232	80,0	82,23	12	25	50	15	20	12,97	5	10	0,59
3	16	32301216	48,0	53,36	15	28	40	15	25	33,64	3	11,6	0,23
	32	33301232	96,0	98,68	15	30	60	15	24	15,31	6	10	1,05
3,5	16	32351216	56,0	62,26	18	33,5	48	15	30	38,83	3,5	14,4	0,40
	32	33351232	112,0	115,12	18	31	70	20	24	17,77	7	10	1,57
4	16	32401216	64,0	71,15	20	36	50	15	32	44,81	4	13,4	0,49
	32	33401232	128,0	131,57	20	32	80	20	24	20,42	8	10	2,29
4,5	16	32451216	72,0	80,05	22	39,5	60	20	35	51,00	4,5	15,4	0,75
	32	33451232	144,0	148	22	36	90	20	27	23,21	9	10	2,99
5	16	32501216	80,0	88,94	25	50	60	20	45	56,06	5	21,1	1,07
	32	33501232	160,0	164,46	25	38	100	20	28	25,52	10	10	3,95

MATERIAL **C 45 UNI 7847**

CAD drawings available on our site
www.chiaravalli.com

Quantity, availability and prices
on B2B Chiaravalli





BEVEL GEAR WITH STRAIGHT TEETH norm DIN 3967

7

RATIO 1:3

Pressure angle: 20°
with normal axes in compliance to
UNI 6588

Teeth according to DIN 3967

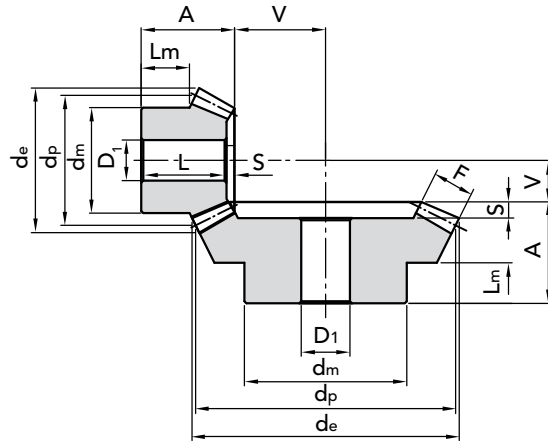

M	Z	PART NUMBER	d_p	d_e	F	A	d_m	D_1	L	V	S	L_m	Kg
1,5	16	32151316	24,0	26,82	12	24	20	10	23	24,32	1	11,7	0,04
	48	33151348	72,0	72,95	12	20	50	12	17	7,27	3	10	0,31
2	16	32201316	32,0	35,8	15	28,5	26	12	27	33,26	1,5	12,4	0,08
	48	33201348	96,0	97,26	15	23	60	15	19	9,90	4	10	0,67
2,5	16	32251316	40,0	44,74	18	32	32	12	30	42,41	1,5	13	0,15
	48	33251348	120,0	121,58	18	26	70	20	21	12,60	5	10	1,22
3	16	32301316	48,0	53,69	18	32	40	15	30	54,25	2	12,1	0,27
	48	33301348	144,0	145,9	18	29	80	20	23	16,20	6	10	2,01
3,5	16	32351316	56,0	62,64	22	38	48	15	35,5	62,29	2,5	15	0,45
	48	33351348	168,0	170,21	22	31	90	20	24	18,48	7	10	3,08
4	16	32401316	64,0	71,59	25	41,5	55	20	38,5	71,23	3	15,2	0,67
	48	33401348	192,0	194,53	25	33	100	20	25	21,20	8	10	4,40
4,5	16	32451316	72,0	80,53	28	53	60	20	50	80,27	3	23,4	1,05
	48	33451348	216,0	218,84	28	49	100	20	40	23,93	9	18	7,23
5	16	32501316	80,0	89,48	35	60	60	20	57	85,61	3	22,5	1,38
	48	33501348	240,0	243,16	35	50	150	20	40	25,45	10	20	8,72

BEVEL GEAR WITH STRAIGHT TEETH RATIO 1:3

6

MATERIAL C 45 UNI 7847

CAD drawings available on our site
www.chiaravalli.com

Quantity, availability and prices
on B2B Chiaravalli





RATIO 1:4

Pressure angle: 20°
with normal axes in compliance to
UNI 6588

Teeth according to DIN 3967

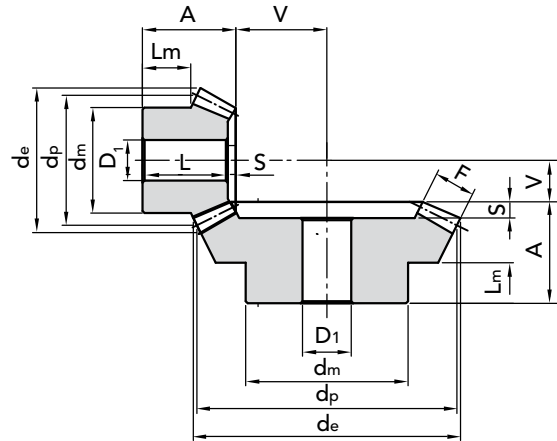

M	Z	PART NUMBER	d_p	d_e	F	A	d_m	D_1	L	V	S	L_m	Kg
1,5	16	32151416	24,0	26,91	12	25	18	10	24	36,09	1	12,2	0,04
	64	33151464	96,0	96,73	12	22	70	15	19	8	3	10	0,75
2	16	32201416	32,0	35,88	15	24	25	12	23	49	1	8,2	0,08
	64	33201464	128,0	128,97	15	24	80	20	20	10,88	4	10	1,35
2,5	16	32251416	40,0	44,85	18	30,5	30	12	29	62,07	1,5	11,7	0,18
	64	33251464	160,0	161,21	18	29	90	20	24	13,74	5	10	2,70
3	16	32301416	48,0	53,82	22	34	40	15	32	74,10	2	11	0,29
	64	33301464	192,0	193,45	22	30	100	20	24	16,41	6	10	4,12
3,5	16	32351416	56,0	62,8	25	45	48	15	43	87,10	2	19,1	0,48
	64	33351464	224,0	225,7	25	50	100	20	43	19,28	7	22	7,53
4	16	32401416	64,0	71,76	30	50	50	20	48	98,17	2	18,5	0,75
	64	33401464	256,0	257,94	30	50	120	20	42	21,76	8	20	10,66
4,5	16	32451416	72,0	80,73	32	53	55	20	50,5	112,08	2,5	19	1,12
	64	33451464	288,0	290,18	32	53	130	20	44	24,83	9	23	13,8
5	16	32501416	80,0	89,7	35	58	60	20	55,5	125,12	2,5	20,6	1,54
	64	33501464	320,0	322,42	35	58	150	20	48	27,73	10	25	15,6

MATERIAL **C 45 UNI 7847**

CAD drawings available on our site
www.chiaravalli.com

Quantity, availability and prices
on B2B Chiaravalli





BEVEL GEAR WITH STRAIGHT TEETH SPECIAL CH EXECUTION GLEASON SYSTEM

RATIO 1:1

Normal axis
Pressure angle: 20°

GLEASON SYSTEM

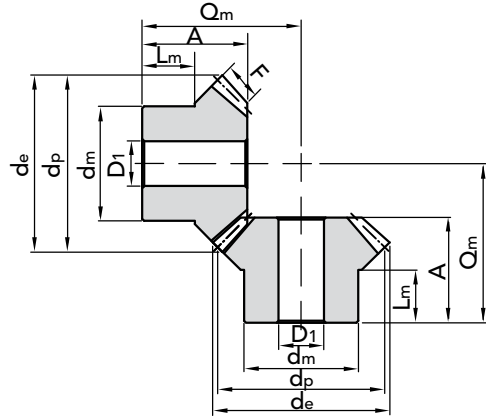

M	Z	PART NUMBER	dp	de	F	A	dm	D1	V	Lm	Kg
1	16	35101116	16	17,4	4	11,2	13,3	4	4,8	6,5	0,02
	19	35101119	19	20,4	4	11,8	15,3	4	6,2	6,5	0,02
	22	35101122	22	23,4	4,7	12,8	16,3	5	7,2	6,5	0,02
	26	35101126	26	27,4	5,5	13,3	20,3	5	8,7	7	0,04
	30	35101130	30	31,4	6,4	16	20,3	5	10	8	0,05
1,5	16	35151116	24	26,1	6	18,9	20,3	8	7,1	12	0,04
	19	35151119	28,5	30,6	7	21,3	20,3	8	8,7	12	0,05
	22	35151122	33	35,1	7,5	22,5	25,3	8	10,5	12	0,09
	26	35151126	39	41,1	8,5	23,2	28,3	8	12,8	12	0,12
	30	35151130	45	47,1	10	27,2	30,3	12	14,8	12	0,17
2	16	35201116	32	34,8	8	23,5	25,3	8	9,5	14	0,08
	19	35201119	38	40,8	9	24,2	25,3	8	11,8	12	0,11
	22	35201122	44	46,8	10	27,9	30,3	12	14,1	14	0,18
	26	35201126	52	54,8	12	31,4	35,3	12	16,6	14	0,28
	30	35201130	60	62,8	13	34,1	40,3	14	19,9	17	0,41
2,5	16	35251116	40	43,5	10	28,1	30,3	12	11,9	15	0,14
	19	35251119	47,5	51	11	27,1	35,3	12	14,9	13	0,21
	22	35251122	55	58,5	12	30,1	45,3	16	17,9	16	0,36
	26	35251126	65	68,5	15	33,2	45,3	16	20,8	16	0,47
	30	35251130	75	78,5	16	39	50,3	16	25	20	0,74
3	16	35301116	48	52,5	12	31,7	40,3	12	14,3	18	0,28
	19	35301119	57	61,2	13	36	40,3	14	18	17	0,39
	22	35301122	66	70,2	15	36,9	50,3	16	21,1	17	0,59
	26	35301126	78	82,2	17	38,4	50,3	16	25,6	18	0,77
	30	35301130	90	94,2	19	43,8	60,3	20	30,2	22	1,19
3,5	16	35351116	56	60,9	14	36,4	45,3	16	16,6	20	0,41
	19	35351119	66,5	71,5	15	37,8	50,3	18	21	19	0,59
	22	35351122	77	81,9	17	39,1	55,3	20	24,9	18	0,84
	26	35351126	91	96	20	43,35	62,3	20	29,7	20	1,17
	30	35351130	105	110	23	47,1	70,3	20	34,9	22	1,69
4	16	35401116	64	69,7	15	44,3	50,3	16	19,7	25	0,66
	19	35401119	76	81,7	18	44,4	55,3	20	23,6	22	0,88
	22	35401122	88	93,7	20	45,9	60,3	20	28,1	22	1,21
	26	35401126	104	109,7	23	48	70,3	20	34	22	1,68
	30	35401130	120	125,7	26	54,2	80,3	20	39,8	25	2,50
4,5	16	35451116	72	78,4	17,5	46,3	55,3	20	21,7	25	0,84
	19	35451119	85,5	91,8	20	49	62,3	20	26,57	25	1,15
	22	35451122	99	105,3	22	50,1	70,3	20	31,9	25	1,72
	26	35451126	117	123	25	54,7	75,3	20	38,6	26	2,22
	30	35451130	135	141,4	29	60	80,3	20	45	28	3,25
5	16	35501116	80	87,1	18	48,9	60,3	20	25,1	25	1,10
	19	35501119	95	102,1	22	52,2	60,3	20	29,8	25	1,50
	22	35501122	110	117,1	24	58,2	80,3	20	35,8	30	2,39
	26	35501126	130	137,1	29	62,7	80,3	20	42,3	30	3,27
	30	35501130	150	157,1	32	68,9	80,3	20	50,1	35	4,13

BEVEL GEAR WITH STRAIGHT TEETH SPECIAL CH EXECUTION RATIO 1:1

MATERIAL **C 45 UNI 7847**



CAD drawings available on our site
www.chiaravalli.com

Quantity, availability and prices
on B2B Chiaravalli

BEVEL GEAR WITH STRAIGHT TEETH SPECIAL CH EXECUTION GLEASON SYSTEM

BEVEL GEAR WITH STRAIGHT TEETH SPECIAL CH EXECUTION RATIO 1:1.5
RATIO 1:1.5

Normal axis

Pressure angle: 20°

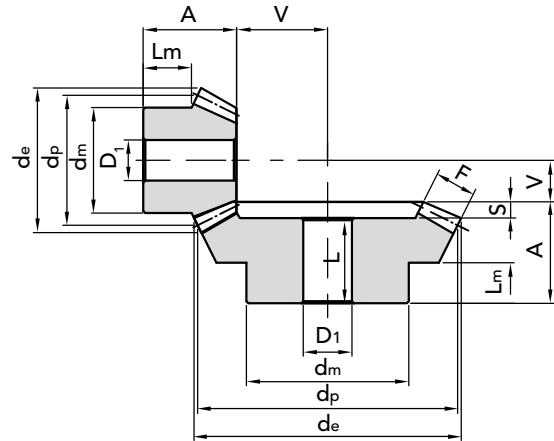
GLEASON SYSTEM

M	Z	PART NUMBER	d_p	d_e	F	A	d_m	D_1	L	V	S	L_m	Kg
1	16	35101516	16	18,1	4,3	12	13,3	4		8		7	0,04
	24	36101524	24	24,8	4,3	14,8	20,3	5	13,3	5,2	1,5	9,3	0,05
1,5	16	35151516	24	27,1	8	20,3	20,3	8		10,7		11,8	0,04
	24	36151524	36	37,2	8	24,9	28,3	8	22,7	7,1	2,2	16	0,04
2	16	35201516	32	36,2	10	25,2	25,3	8		14,8		13,8	0,08
	24	36201524	48	49,7	10	27,2	32,3	8	24,7	9,8	2,5	16	0,32
2,5	16	35251516	40	45,2	13	30,8	32,3	12		18,2		16,4	0,14
	24	36251524	60	62,1	13	34	45,3	14	30,8	12	3,2	20	0,50
3	16	35301516	48	54,3	14,5	32,4	40,3	12		22,6		16,4	0,28
	24	36301524	72	74,5	14,5	36,2	55,3	16	32	14,8	4,2	20	0,96
3,5	16	35351516	56	63,3	18	40,4	45,3	16		25,6		20,4	0,41
	24	36351524	84	86,9	18	44,2	55,3	20	40	16,8	4,2	25	1,30
4	16	35401516	64	72,4	18	46,8	50,3	16		31,2		25,4	0,66
	24	36401524	96	99,3	18	45,5	60,3	20	40	20,5	5,5	25	2,50
4,5	16	35451516	72	81,4	20	47,6	60,3	20		35,4		25,1	0,84
	24	36451524	108	111,7	20	57,8	80,3	20	51,3	23,2	6,5	35	2,90
5	16	35501516	80	90,5	24	54,1	60,3	20		37,9		25,4	1,10
	24	36501524	120	124,1	24	61,1	80,3	20	54,5	24,9	6,6	35	3,50

MATERIAL C 45 UNI 7847

 CAD drawings available on our site
www.chiaravalli.com

 Quantity, availability and prices
 on B2B Chiaravalli





BEVEL GEAR WITH STRAIGHT TEETH SPECIAL CH EXECUTION GLEASON SYSTEM

RATIO 1:2

Normal axis

Pressure angle: 20°

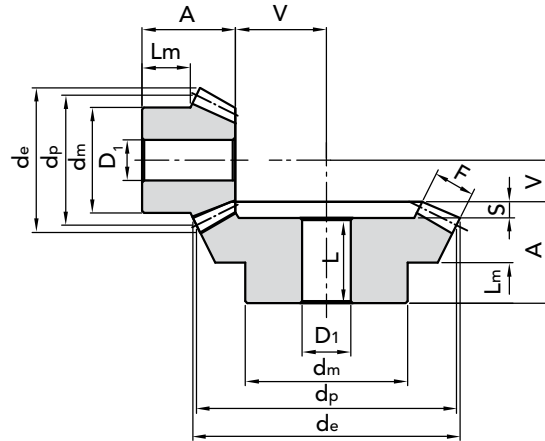
GLEASON SYSTEM



M	Z	PART NUMBER	d_p	d_e	F	A	d_m	D_1	L	V	S	L_m	Kg
1	15	35101215	15	17,4	5	11,9	13,3	4		10,1		6,5	0,03
	30	36101230	30	30,6	5	15,1	20,3	5	13,7	4,9	1,4	9	0,06
1.5	15	35151215	22,5	26,1	9	21,1	19,3	8		13,9		11,9	0,04
	30	36151230	45	45,9	9	25,2	32,3	8	23	6,8	2,2	16	0,19
2	15	35201215	30	34,8	11,5	26	25,3	8		19		14,1	0,09
	30	36201230	60	61,2	11,5	29,8	40,3	14	26,8	9,2	3	18	0,32
2.5	15	35251215	37,5	43,5	15	31,8	32,3	12		23,2		16,2	0,17
	30	36251230	75	76,5	15	33,7	45,3	16	30	11,3	3,7	20	0,57
3	15	35301215	45	52,2	17	37,3	40,3	12		28,7		19,9	0,25
	30	36301230	90	91,8	17	42,1	55,3	16	38	13,9	4,1	25	1,03
3.5	15	35351215	52,5	60,9	20,5	46,1	45,3	16		32,9		24,7	0,42
	30	36351230	105	107,1	20,5	45	60,3	20	40	16	5	25	1,51
4	15	35401215	60	69,6	22,5	48,6	50,3	20		38,4		24,6	0,52
	30	36401230	120	122,3	22,5	57,3	80,3	20	51,9	18,7	5,4	35	2,21
4.5	15	35451215	67,5	78,3	26	51,4	60,3	20		42,6		24,7	0,8
	30	36451230	135	137,6	26	60,3	80,3	20	54,3	20,7	6	35	2,88
5	15	35501215	75	87	30	57,6	60,3	20		46,4		25,3	1,16
	30	36501230	150	152,9	30	62,5	80,3	20	56	22,5	6,5	35	2,79

BEVEL GEAR WITH STRAIGHT TEETH SPECIAL CH EXECUTION RATIO 1:2

MATERIAL **C 45 UNI 7847**

CAD drawings available on our site
www.chiaravalli.com

Quantity, availability and prices
on B2B Chiaravalli



BEVEL GEAR WITH STRAIGHT TEETH SPECIAL CH EXECUTION GLEASON SYSTEM

BEVEL GEAR WITH STRAIGHT TEETH SPECIAL CH EXECUTION RATIO 1:2.5

RELATION 1:2.5

Normal axis
Pressure angle: 20°

GLEASON SYSTEM

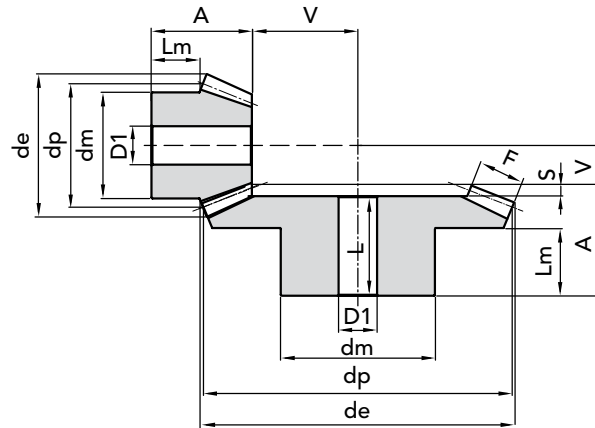

M	Z	PART NUMBER	d_p	d_e	F	A	d_m	D_1	L	V	S	L_m	Kg
1	16	35102516	16	18,6	6,5	14,4	13,3	4		13,6		7,4	0,04
	40	36102540	40	40,4	6,5	14,8	25,3	8	13	5,2	1,8	9	0,09
1.5	16	35152516	24	27,9	11,5	24,2	20,3	8		18,8		12,3	0,04
	40	36152540	60	60,7	11,5	27,8	40,3	14	25,5	7,2	2,3	18	0,17
2	16	35202516	32	37,2	15	29,6	25,3	8		25,4		13,7	0,04
	40	36202540	80	80,9	15	32,4	45,3	16	29	9,6	3,4	20	0,15
2.5	16	35252516	40	46,4	19	38,4	32,3	12		31,6		18,5	0,17
	40	36252540	100	101,1	19	39,8	55,3	16	35,9	12,2	3,9	25	1,23
3	16	35302516	48	55,7	21,5	41,9	40,3	16		39,1		19,6	0,33
	40	36302540	120	121,4	21,5	47,9	60,3	20	44	15,1	3,9	30	1,83
3.5	16	35352516	56	65	22,6	49,1	45,3	20		47,9		25	0,33
	40	36352540	140	141,6	22,6	54,6	80,3	20	50	18,4	4,6	35	1,90
4	16	35402516	64	74,3	26	52,5	55,3	20		54,5		25,3	0,65
	40	36402540	170	161,8	26	57,0	80,3	20	50,5	21	6,5	35	2,53
4.5	16	35452516	72	83,6	30	56,3	60,3	20		60,7		24,6	0,97
	40	36452540	180	182,1	30	59,7	80,3	20	53	23,3	6,7	35	5,30
5	16	35502516	80	92,9	32	65,4	60,3	20		68,6		30,1	1,23
	40	36502540	200	202,3	32	65,7	90,3	20	58,3	26,3	7,4	40	7,20

MATERIAL **C 45 UNI 7847**

CAD drawings available on our site
www.chiaravalli.com

Quantity, availability and prices
on B2B Chiaravalli





BEVEL GEAR WITH STRAIGHT TEETH SPECIAL CH EXECUTION GLEASON SYSTEM

13

RELATION 1:3

Normal axis
Pressure angle: 20°

GLEASON SYSTEM

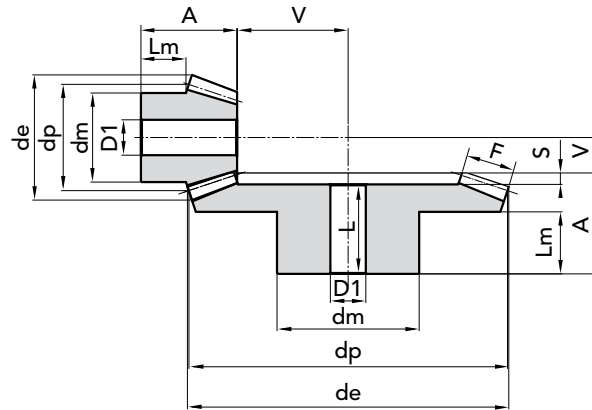

M	Z	PART NUMBER	d_p	d_e	F	A	d_m	D_1	L	V	S	L_m	Kg
1	15	35101315	15	17,7	7,1	16,6	13,3	4		15,4		9,2	0,03
	45	36101345	45	45,3	7,1	17,1	25,3	8	15,2	4,9	1,9	10	0,09
1.5	15	35151315	22,5	26,5	10,5	22,6	19,3	8		23,4		11,7	0,04
	45	36151345	67,5	68,1	10,5	29,6	45,3	14	27,2	7,4	2,4	20	0,40
2	15	35201315	30	35,4	14	28,9	25,3	8		31,1		14,2	0,09
	45	36201345	90	90,8	14	32,1	45,3	16	28,4	9,9	3,7	20	0,62
2.5	15	35251315	37,5	44,2	18	34,6	32,3	12		38,4		15,9	0,17
	45	36251345	112,5	113,4	18	39,7	60,3	20	35,3	12,3	4,4	25	1,19
3	15	35301315	45	53	21	41,3	40,3	16		46,7		19,7	0,29
	45	36301345	135	136,1	21	47,2	60,3	20	42	14,8	5,2	30	1,91
3.5	15	35351315	52,5	61,9	23,5	49,6	45,3	20		55,4		25	0,48
	45	36351345	157,5	158,8	23,5	54,4	80,3	20	48,6	17,6	5,8	35	2,21
4	15	35401315	60	70,7	27,5	54,3	50,3	20		62,7		25,4	0,70
	45	36401345	180	181,5	27,5	57	80,3	20	50,5	20	6,5	35	4,21
4.5	15	35451315	67,5	79,5	28,5	55,2	55,3	20		72,8		24,8	1,14
	45	36451345	202,5	204,2	28,5	63,9	90,3	20	57	23,1	6,9	40	7,03
5	15	35501315	75	88,4	33	65,3	60,3	20		79,7		30	1,45
	45	36501345	225	226,9	33	66,7	90,3	20	59,2	25,3	7,5	40	8,42

BEVEL GEAR WITH STRAIGHT TEETH SPECIAL CH EXECUTION RATIO 1:3

6

MATERIAL C 45 UNI 7847

CAD drawings available on our site
www.chiaravalli.com

Quantity, availability and prices
on B2B Chiaravalli



BEVEL GEAR WITH STRAIGHT TEETH SPECIAL CH EXECUTION GLEASON SYSTEM

BEVEL GEAR WITH STRAIGHT TEETH SPECIAL CH EXECUTION RATIO 1:3.5

RATIO 1:3.5

Normal axis
Pressure angle: 20°

GLEASON SYSTEM

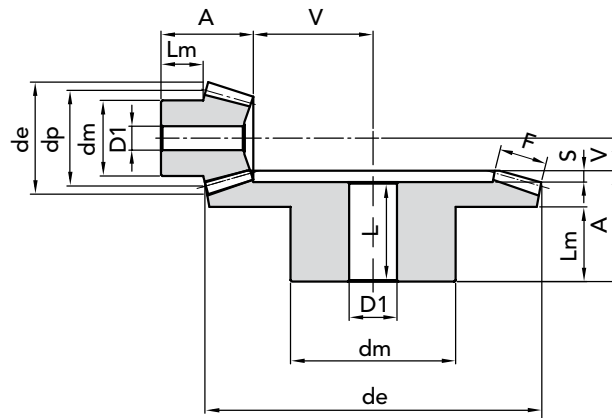

M	Z	PART NUMBER	d_p	d_e	F	A	d_m	D_1	L	V	S	L_m	Kg
1.5	16	35153516	24	28,1	12	24,0	20,3	8		30		11,5	0,05
	56	36153556	84	84,5	12	34,8	45,3	14	32	8,2	2,8	25	0,63
2	16	35203516	32	37,5	16	30,9	25,3	8		40,1		14,1	0,09
	56	36203556	112	112,6	16	37,1	55,3	16	33,3	10,9	3,8	25	1,30
2.5	16	35253516	40	46,8	20	38,9	32,3	14		50,1		17,9	0,20
	56	36253556	140	140,8	20	44,4	60,3	20	40	13,6	4,4	30	2,59
3	16	35303516	48	56,2	24	49,9	40,3	16		60,1		24,9	0,31
	56	36303556	168	169	24	52,7	80,3	20	47,5	16,3	5,2	35	3,94
3.5	16	35353516	56	65,6	25	52,0	45,5	20		73		25,5	0,62
	56	36353556	196	197,1	25	55,1	80,3	20	49,1	19,9	6,0	35	5,60

MATERIAL **C 45 UNI 7847**

CAD drawings available on our site
www.chiaravalli.com

Quantity, availability and prices
on B2B Chiaravalli





BEVEL GEAR WITH STRAIGHT TEETH SPECIAL CH EXECUTION GLEASON SYSTEM

15

RATIO 1:4

Normal axis

Pressure angle: 20°

GLEASON SYSTEM

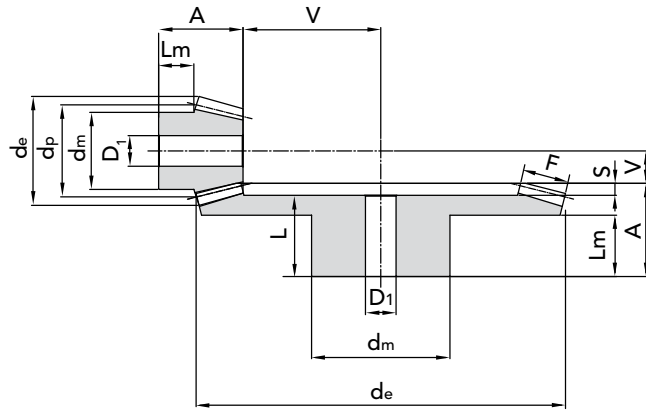

M	Z	PART NUMBER	d_p	d_e	F	A	d_m	D_1	L	V	S	L_m	Kg
1	15	35101415	15	17,8	9,3	17,2	13,3	4		20,8		7,7	0,03
	60	36101460	60	60,3	9,3	17,1	30,3	8	15,2	4,9	1,9	10	0,15
1,5	15	35151415	22,5	26,7	11	23	20,3	8		34		11,7	0,05
	60	36151460	90	90,4	11	34	50,3	16	31,2	8	2,8	25	0,60
2	15	35201415	30	35,6	16	31	25,3	8		44		14,4	0,09
	60	36201460	120	120,6	16	37,6	60,3	16	34,2	10,4	3,4	25	1,30
2,5	15	35251415	37,5	44,5	19	38,1	32,3	14		55,9		18,4	0,20
	60	36251460	150	150,7	19	44,8	60,3	20	40	13,2	4,8	30	2,59
3	15	35301415	45	53,3	23	48,1	40,3	16		66,9		24,5	0,31
	60	36301460	180	180,8	23	53,2	80,3	20	48,2	15,8	5	35	3,94
3,5	15	35351415	52,5	62,2	26	52,1	45,3	20		78,9		25,1	0,60
	60	36351460	210	211	26	60,4	90,3	20	54,4	18,6	6	40	5,62
4	15	35401415	60	71,1	30	55,1	50,3	20		89,9		23	0,81
	60	36401460	240	241,1	30	60,8	90,3	20	53	21,2	7,8	40	6,43
4,5	15	35451415	67,5	79,97	32	57	52,3	20		102,9		23	1,15
	60	36451460	270	271,24	32	62	90,3	20	53,5	24,3	8,5	40	11,35
5	15	35501415	75	88,8	34	62	55,3	20		115,7		25	1,80
	60	36501460	300	301,3	34	65	90,3	20	55	27	10	40	14,45

BEVEL GEAR WITH STRAIGHT TEETH SPECIAL CH EXECUTION RATIO 1:4

6

MATERIAL **C 45 UNI 7847**



CAD drawings available on our site
www.chiaravalli.com

Quantity, availability and prices
on B2B Chiaravalli



The "GLEASON" system range of bevel gears with spiral tothing is an extension of the range of standard bevel gear pairs with which this range shares the declared intentions and objectives.

The criteria adopted comply as closely as possible with International Standards as regards general sizing and the definition of the geometric features, whereas the choice of the key nominal data has been based on a progression depending on the range of the normal numbers established by the **DIN 323** and **ISO R3/R17** standards.

The spiral tothing complying with the "GLEASON" system is the result of a specific project designed to achieve optimised functional features compared with the geometric parameters that frequently conflict with each other.

The key sizing for the tothing, in particular refers to the following:

- The choice of a reduced tooth height - Correction by profile displacement

- Adoption of a normal pressure angle:

$\alpha_n = 20^\circ$ - The constant tooth bottom gap along the whole tooth surface and other geometric solutions. This series of bevel gear with spiral tothing is designed for general use in plants and in general mechanical applications. The project has been designed therefore, to privilege the mechanical performance normally requested by this sector and special attention has been paid in defining the geometric features that can determine the tooth covering factor and the restraining reactions which determine the load on the bevel gear pair bearings.

By their very nature bevel gears with spiral tothing are designed for a more demanding use compared with that of straight teeth bevel gear pairs therefore, CHIARAVALLI GROUP SpA has made available the Company's range of bevel gear pairs with the intention of providing a solution that will be appreciated by the users of this product.

Naturally and in the framework of the Company's traditional technical collaboration with end users, the CHIARAVALLI GROUP SpA technical office is available to provide suggestions concerning more specific circumstances and problems.

GLEASON SYSTEM



Directions and angles of forces acting on spiral bevel gears

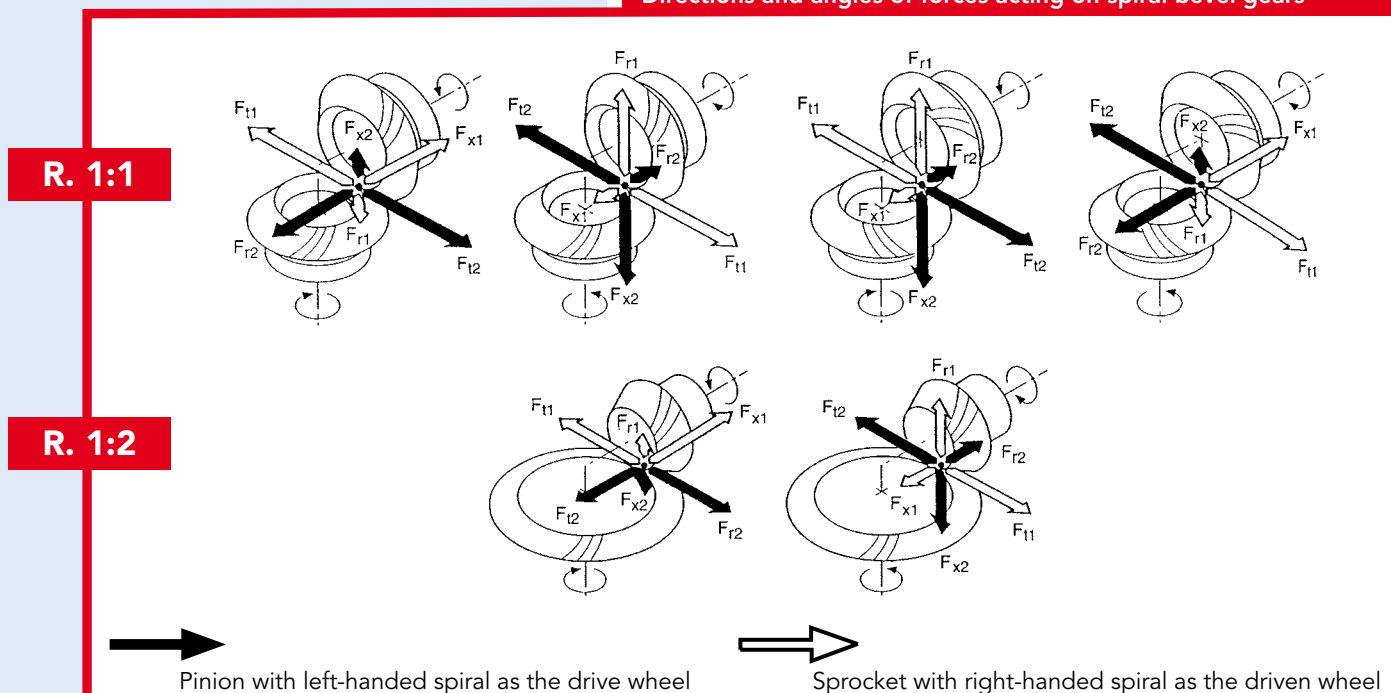



RATIO 1:1

GLEASON SYSTEM

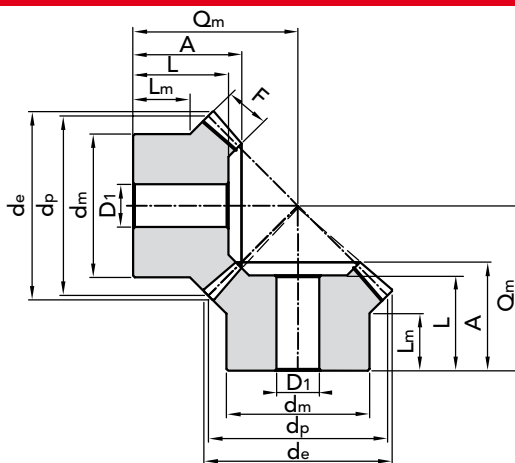

M	Z	PART NUMBER SX	PART NUMBER DX	d_p	d_m	D_1	F	d_e	L_m	L	A	Q_m	Kg
1,5	16	31151116	31151117	24	18	8	6	25,3	9	16	16,7	24	0,04
	20	31151120	31151121	30	22	8	7	31,3	10	18	19,4	29	-0,05
	25	31151125	31151126	37,5	28	8	8	38,8	11,5	21	22,5	35	-0,1
	30	31151130	31151131	45	32	10	10	46,3	11	23	25,1	40	0,40
2	16	31201116	31201117	32	25	10	9	34	9,45	16,9	19,9	29	0,06
	20	31201120	31201121	40	32	10	12	42	11,95	21,7	24,9	36	-0,05
	25	31201125	31201126	50	40	12	14	52	11,9	24,8	27,4	42	-0,1
	30	31201130	31201131	60	50	12	16	62	12,95	26,9	29,9	48	0,42
2,5	16	31251116	31251117	40	32	12	10	42,5	13	21,8	24,8	37	0,13
	20	31251120	31251121	50	40	12	12	52,5	16	26,7	30,2	46	-0,05
	25	31251125	31251126	62,5	50	15	15	65	16	29,9	33,2	53	-0,1
	30	31251130	31251131	75	55	15	18	77,5	16	31,8	35	59	0,69
3	16	31301116	31301117	48	40	15	12	51	16	25,8	29,4	44	0,23
	20	31301120	31301121	60	45	15	18	63	13,5	30,7	34,5	51	-0,076
	25	31301125	31301126	75	55	15	20	78	16	33,7	37,5	60	-0,127
	30	31301130	31301131	90	60	20	22	93	19	35,8	39,5	68	0,99
4	16	31401116	31401117	64	50	15	15	68	17,75	30,8	36	56	0,51
	20	31401120	31401121	80	60	18	17	84	18	32,5	37,5	64	-0,102
	25	31401125	31401126	100	70	20	21	104	18	35,2	40,4	74	-0,152
	30	31401130	31401131	120	80	25	25	124	16	38,1	43,2	84	2,10
5	16	31501116	31501117	80	60	20	17	85	18,9	35,5	41,9	68	0,88
	20	31501120	31501121	100	70	20	21	105	18,5	37,7	44,8	78	-0,127
	25	31501125	31501126	125	90	20	26	130	18,5	41,8	47,8	90	-0,178
	30	31501130	31501131	150	110	30	32	155	18	45,7	52,5	103	4,25

SPIRAL BEVEL GEARS RATIO 1:1

6

MATERIAL C 45 UNI 7847



CAD drawings available on our site
www.chiaravalli.com

**Quantity, availability and prices
on B2B Chiaravalli**

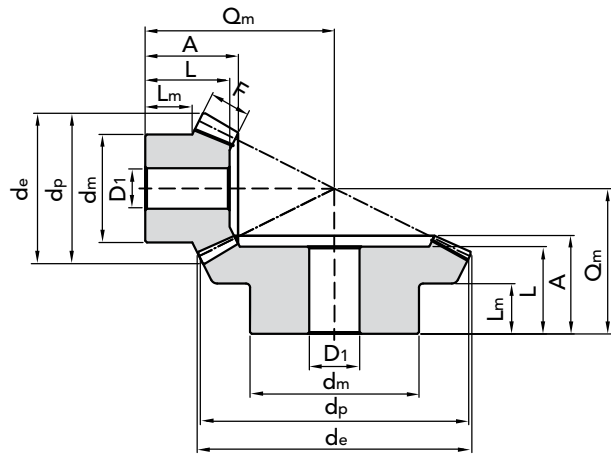
RATIO 1:2
GLEASON SYSTEM

M	Z	PART NUMBER SX	PART NUMBER DX	d_p	d_m	D_1	F	d_e	L_m	L	A	Q_m	Kg	
1,5	16	31151216		24	20	10	8	26,5	9,5	17	18,6	35	-0,05 -0,1	0,07
	32		31151232	48	32	12	8	48,3	10	18	20	28	-0,05 -0,1	0,29
2	16	31201216		32	27	10	10	35,5	11,7	21	22,5	45	-0,05 -0,1	0,09
	32		31201232	64	40	12	10	64,5	10	21,5	24,1	35	-0,05 -0,1	0,32
3	16	31301216		48	40	15	15	53,5	12	25,2	28,4	62	-0,076 -0,127	0,25
	32		31301232	96	60	15	15	97	15	29,8	34,6	51	-0,076 -0,127	1,03
4	16	31401216		64	50	20	20	71,5	13,5	32,2	36,2	81	-0,102 -0,152	0,52
	32		31401232	128	80	20	20	129	23	38,7	44,2	66	-0,102 -0,152	2,21
5	16	31501216		80	60	20	25	89,5	21	45,3	50	106	-0,127 -0,178	1,16
	32		31501232	160	90	25	25	162	27	46,8	53,7	81	-0,127 -0,178	2,79

 MATERIAL **C 43 UNI 7847**

 CAD drawings available on our site
www.chiaravalli.com

 Quantity, availability and prices
 on B2B Chiaravalli







SPECIAL PRODUCTIONS ON REQUEST



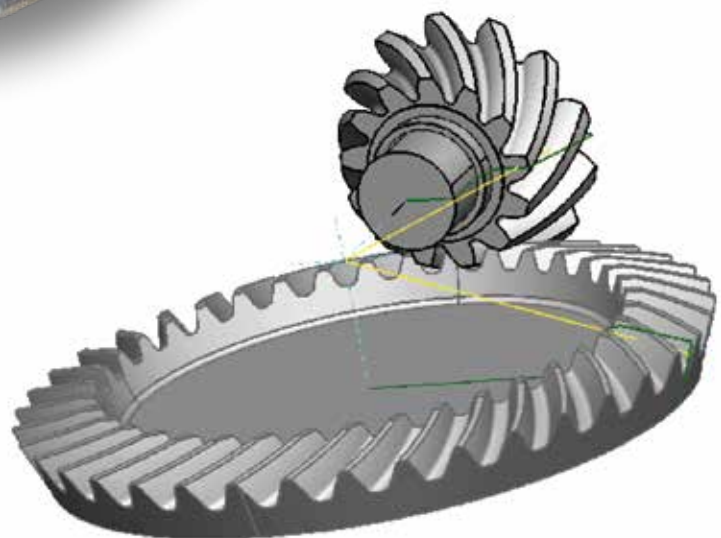
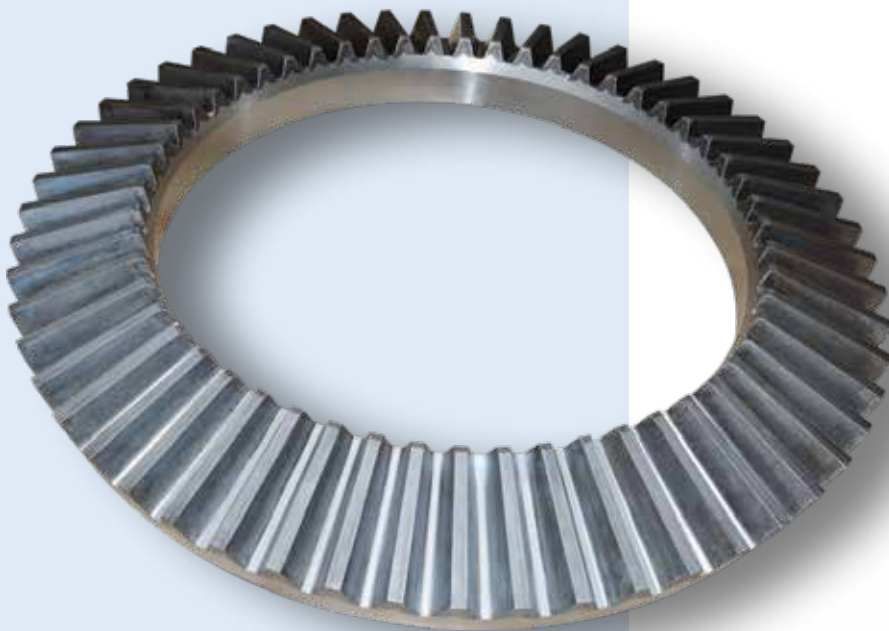

Bevel toothing
straight teeth or spiral
helical GLEASON SYSTEM
case-hardened or ductile
with minimum dimensions from...
to maximum...
in quality **Class 7**
according to **DIN 3962**





OUR MACHINE TOOLS FLEET

OUR MACHINE TOOLS FLEET



A very modern machine tools fleet, constantly updated with annual fixed important investments.

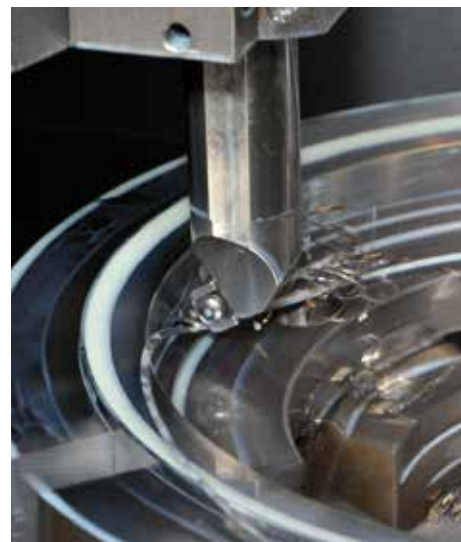



A wide range of three-dimensional measuring machines to assure a certified quality.



TIMING PULLEYS

TIMING PULLEYS WITH PILOT BORE

TYPE MXL - XL - L - H - XH - XXH

page 5

TAPER-LOCK[®] TIMING PULLEYS

TYPE L - H

20

HTD[®] TIMING PULLEYS WITH PILOT BORE

TYPE 3M - 5M - 8M - 14M

28

HTD[®] TAPER LOCK[®] TIMING PULLEYS

TYPE 5M - 8M - 14M

44

POLY CHAIN[®] GT[®] TIMING PULLEYS

TYPE 8M - 14M

56

"T" METRIC TIMING PULLEYS

TYPE T2,5 - T5 - T10

66

"CT" METRIC TIMING PULLEYS

TYPE CT5 - CT10

76



TIMING PULLEYS

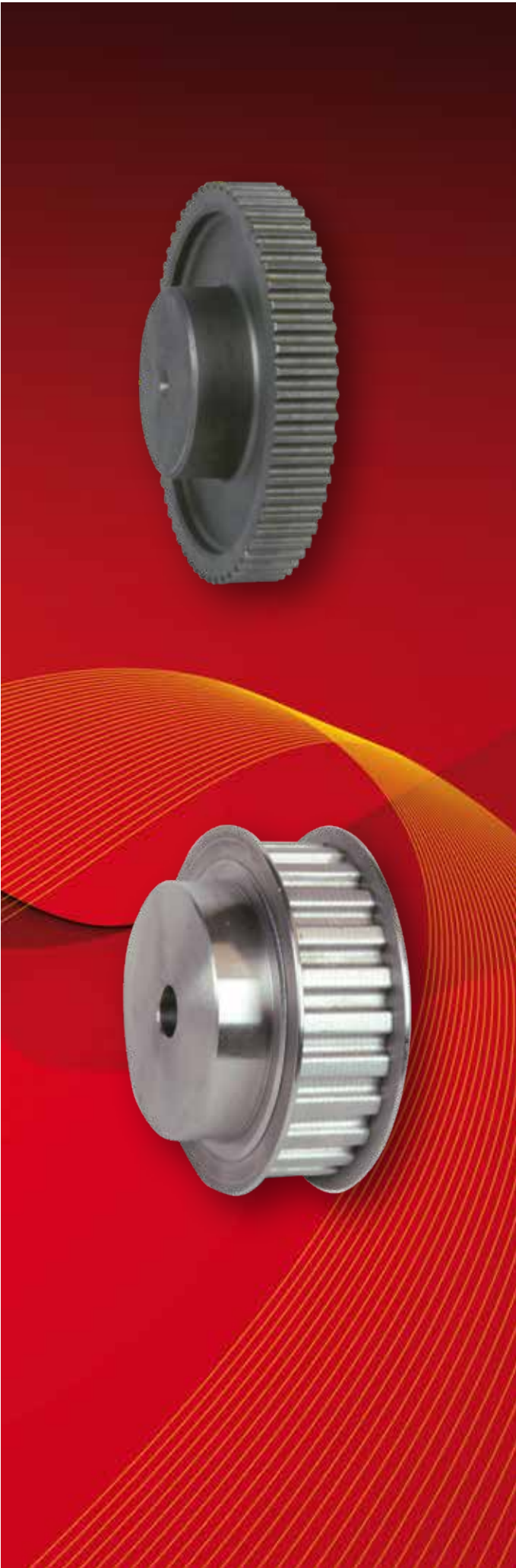



FOR SYNCHRONOUS DRIVES

Toothed belts and pulleys are of major importance in synchronous drives based on flexible components.

These components enable problems to be overcome efficiently and very economically, problems that would otherwise require the use of kinematic motion gearing or transmissions with articulated link chains.

In fact, the performance provided by synchronous belt drives is analogous to the characteristic performance of both chains and gearing however belts and pulleys by comparison have additional advantages deriving from their structural features.

This evident versatility in application is essentially due to the operating characteristics that are common to all toothed belt synchronous drives, and they can be summarised as follows:

- Transmission of absolute asynchronous motion due to the complete absence of slipping.
- Regular and constant motion, since the toothed belt is free from polygonal winding and the consequent speed variation typical of chain transmissions.
- Non-extendable belt that transmits the motion without significant stretching and therefore without lost motion.
- Moderate assembly pre-tension, since adhesion is not required between the belt and the pulley.
- Minimum radial load on the shafts and on the bearings.
- High capacity to transmit power and high torques at low speed.
- Silent running, good performance, minimum overall dimensions and limited maintenance requirements.

The quality of synchronous transmission depends to an equal extent on the characteristics of both the belt and the pulley, which therefore must comply with demanding design and construction criteria.

CHIARAVALLI GROUP SpA avails of the technical collaboration of the most qualified manufacturers of belts worldwide and produces the Company's complete range of toothed pulleys in compliance with current Standards, but implementing a series of adjustments designed to improve the matching characteristics with the belt.

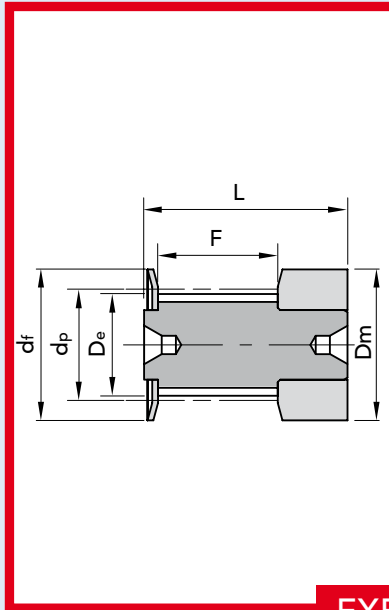

EXECUTION OF

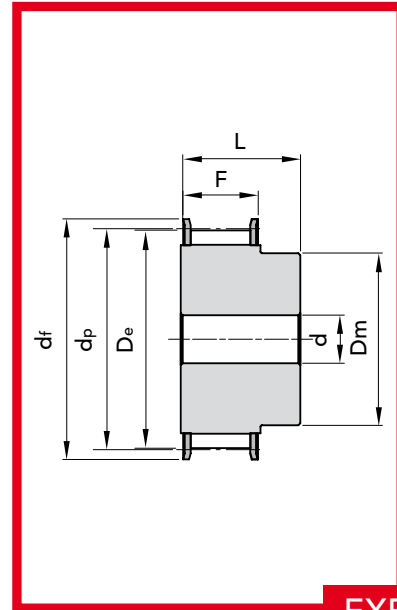

EXECUTION 1F

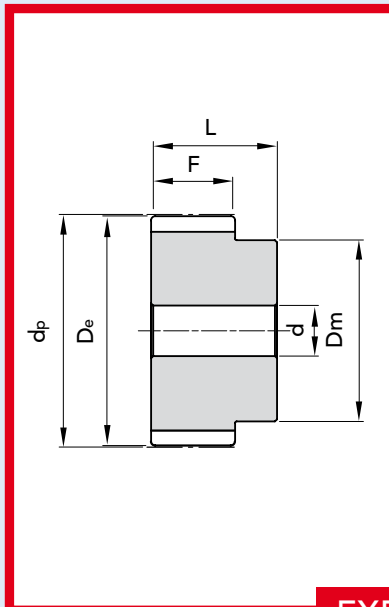

EXECUTION 2

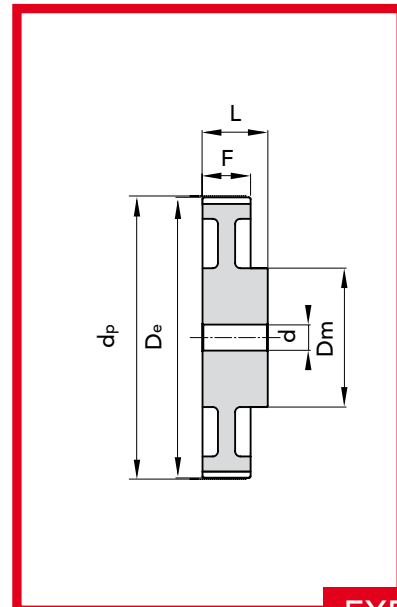

EXECUTION 3

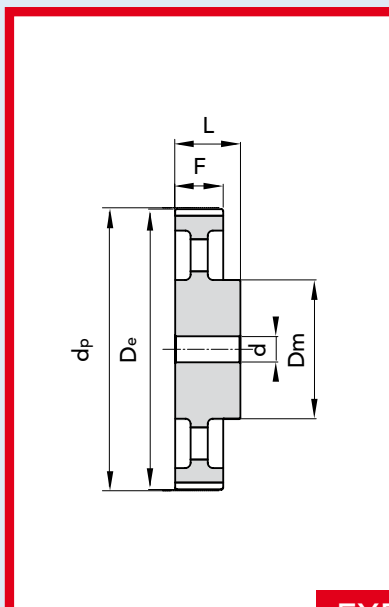

EXECUTION 4

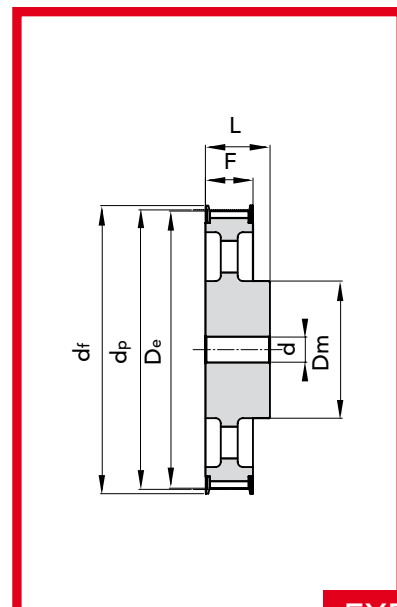

EXECUTION 5F



TIMING PULLEYS with PILOT BORE

FOR POSITIVE BELTS

TYPE **MXL 025**

PITCH 0.080" (2.032 mm)

Different pitch of teeth available on request.

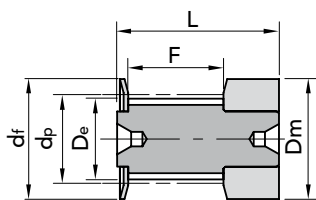

EXEC. 0F

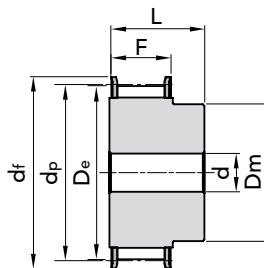

EXEC. 1F

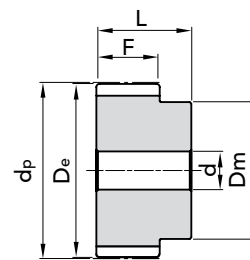

EXEC. 2

TYPE	P. NUMBER	N. TEETH	EXEC.	Dp	De	Df FLANGE	Dm HUB	F	L	d	N. FLANGE	WEIGHT kg.
16 MXL 025	42025116	16	0F	10,35	9,84	15	15	8,5	16,0	-	502	0,01
18 MXL 025	42025118	18	0F	11,64	11,12	16	16	8,5	16,0	-	503	0,01
20 MXL 025	42025120	20	0F	12,94	12,43	16	16	8,5	16,0	-	503	0,01
22 MXL 025	42025122	22	1F	14,23	13,72	17	10	11	16,0	3	504	0,01
24 MXL 025	42025124	24	1F	15,52	15,01	20	10	11	16,0	3	505	0,01
28 MXL 025	42025128	28	1F	18,11	17,60	25	11	11	16,0	3	506	0,01
30 MXL 025	42025130	30	1F	19,40	18,90	25	12	11	16,0	4	506	0,02
32 MXL 025	42025132	32	1F	20,70	20,19	26	14	11	16,0	4	507	0,02
36 MXL 025	42025136	36	1F	23,29	22,78	28	16	11	16,0	4	508	0,02
40 MXL 025	42025140	40	1F	25,87	25,37	32	18	11	16,0	4	509	0,03
42 MXL 025	42025142	42	1F	27,17	26,67	32	18	11	16,0	5	509	0,03
44 MXL 025	42025144	44	1F	28,46	27,95	36	18	11	16,0	5	510	0,03
48 MXL 025	42025148	48	2	31,05	30,54	-	20	11	16,0	5	-	0,03
60 MXL 025	42025160	60	2	38,81	38,30	-	24	11	16,0	5	-	0,04
72 MXL 025	42025172	72	2	46,57	46,06	-	25	11	16,0	6	-	0,05

MATERIAL **ALUMINIUM**

CAD drawings available on our site www.chiaravalli.com

Quantity, availability and prices on B2B Chiaravalli



The images do not identify the products.

TIMING PULLEYS with PILOT BORE TYPE MXL 025



FOR POSITIVE BELTS

TYPE **XL 037**

PITCH 1/5" (5.08 mm)

Different pitch of teeth available on request.

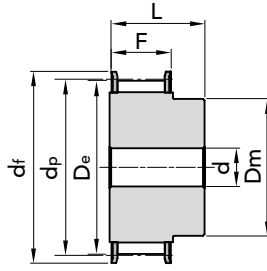

EXEC. 1F

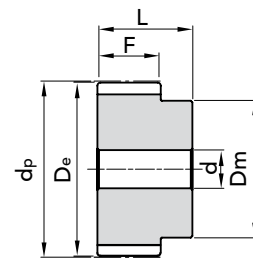

EXEC. 2

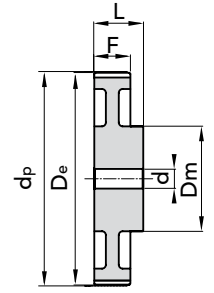

EXEC. 3

TYPE	P. NUMBER ALUMINIUM	P. NUMBER STEEL	N. TEETH	EXEC.	Dp	De	Df FLANGE	Dm HUB	F	L	d	N. FLANGE	WEIGHT Al kg.	WEIGHT Steel kg.
10 XL 037	42037110	42037010	10	1F	16,17	15,66	23	9,5	14,3	20	-	1	0,01	0,028
11 XL 037	42037111	42037011	11	1F	17,79	17,28	23	9,5	14,3	20	-	1	0,01	0,028
12 XL 037	42037112	42037012	12	1F	19,40	18,90	25	10	14,3	20	-	2	0,01	0,028
13 XL 037	42037113	42037013	13	1F	21,02	20,51	25	10	14,3	20	-	2	0,01	0,028
14 XL 037	42037114	42037014	14	1F	22,64	22,13	28	15	14,3	20	-	4	0,02	0,056
15 XL 037	42037115	42037015	15	1F	24,26	23,75	28	15	14,3	20	-	4	0,02	0,056
16 XL 037	42037116	42037016	16	1F	25,87	25,36	32	16	14,3	20	-	5	0,03	0,08
17 XL 037	42037117	42037017	17	1F	27,49	26,98	32	20	14,3	20	-	6	0,03	0,08
18 XL 037	42037118	42037018	18	1F	29,11	28,60	35	20	14,3	20	-	7	0,04	0,1
19 XL 037	42037119	42037019	19	1F	30,72	30,22	35	20	14,3	22	-	7	0,04	0,1
20 XL 037	42037120	42037020	20	1F	32,34	31,83	38	23,5	14,3	22	-	9	0,05	0,14
21 XL 037	42037121	42037021	21	1F	33,96	33,45	38	23,5	14,3	22	-	9	0,05	0,14
22 XL 037	42037122	42037022	22	1F	35,57	35,07	41	25	14,3	22	6	10	0,06	0,16
24 XL 037	42037124	42037024	24	1F	38,81	38,30	44	30	14,3	22	6	12	0,06	0,16
26 XL 037	42037126	42037026	26	1F	42,04	41,53	48	30	14,3	22	8	11	0,09	0,25
27 XL 037	42037127	42037027	27	1F	43,66	43,15	48	30	14,3	22	8	11	0,09	0,25
28 XL 037	42037128	42037028	28	1F	45,28	44,77	51	34	14,3	22	8	16	0,10	0,28
30 XL 037	42037130	42037030	30	1F	48,51	48,00	54	38	14,3	22	8	18	0,12	0,3
32 XL 037	42037132	42037032	32	1F	51,74	51,24	57	38	14,3	22	8	20	0,12	0,3
34 XL 037	42037134	42037034	34	1F	54,98	54,47	61	38	14,3	25	8	22	0,13	0,3
35 XL 037	42037135	42037035	35	1F	56,60	56,09	61	38	14,3	25	8	22	0,14	0,4
36 XL 037	42037136		36	2	58,21	57,70	-	45	14,3	25	8	-	0,14	-
38 XL 037	42037138		38	2	61,45	60,94	-	45	14,3	25	8	-	0,15	-
40 XL 037	42037140		40	2	64,68	64,17	-	45	14,3	25	8	-	0,16	-
42 XL 037	42037142		42	2	67,91	67,41	-	45	14,3	25	8	-	0,18	-
44 XL 037	42037144		44	2	71,15	70,64	-	45	14,3	25	8	-	0,19	-
48 XL 037	42037148		48	3	77,62	77,11	-	45	14,3	25	10	-	0,19	-
60 XL 037	42037160		60	3	97,02	96,51	-	45	14,3	25	10	-	0,22	-
72 XL 037	42037172		72	3	116,42	115,92	-	45	14,3	25	10	-	0,44	-

MATERIAL **STEEL/ALUMINIUM**MATERIAL **ALUMINIUM**CAD drawings available on our site
www.chiaravalli.comQuantity, availability and prices
on B2B Chiaravalli



TIMING PULLEYS with PILOT BORE

7

FOR POSITIVE BELTS

TYPE L 050

PITCH 3/8" (9.52 mm)

Different pitch of teeth available on request.

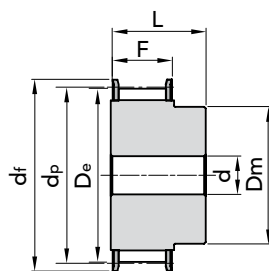

EXEC. 1F

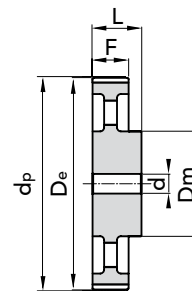

EXEC. 4

TYPE	P. NUMBER	N. TEETH	EXEC.	Dp	De	Df FLANGE	Dm HUB	F	L	d	N. FLANGE	WEIGHT kg.
10 L 050	42050010	10	1F	30,33	29,56	37	20	19	28	8	50	0,11
11 L 050	42050011	11	1F	33,35	32,59	37	22	19	30	8	50	0,14
12 L 050	42050012	12	1F	36,37	35,62	43	24	19	30	8	52	0,17
13 L 050	42050013	13	1F	39,41	38,65	44	28	19	30	8	83	0,21
14 L 050	42050014	14	1F	42,44	41,68	48	28	19	30	8	54	0,24
15 L 050	42050015	15	1F	45,48	44,72	51	34	19	30	8	55	0,29
16 L 050	42050016	16	1F	48,51	47,75	54	36	19	32	8	56	0,33
17 L 050	42050017	17	1F	51,54	50,78	57	36	19	32	10	57	0,38
18 L 050	42050018	18	1F	54,59	53,81	60	40	19	32	10	58	0,44
19 L 050	42050019	19	1F	57,61	56,84	64	40	19	32	10	59	0,47
20 L 050	42050020	20	1F	60,63	59,88	66,5	40	19	32	10	60	0,51
21 L 050	42050021	21	1F	63,68	62,91	70	45	19	32	10	61	0,6
22 L 050	42050022	22	1F	66,70	65,94	75	45	19	32	10	62	0,64
23 L 050	42050023	23	1F	69,73	68,97	79	55	19	32	10	63	0,78
24 L 050	42050024	24	1F	72,77	72,00	79	55	19	32	10	63	0,81
25 L 050	42050025	25	1F	75,80	75,04	82,5	58	19	32	10	64	0,89
26 L 050	42050026	26	1F	78,84	78,07	86	58	19	32	11	65	0,94
27 L 050	42050027	27	1F	81,86	81,10	86	58	19	32	11	65	0,99
28 L 050	42050028	28	1F	84,89	84,13	91	58	19	32	11	66	1,04
30 L 050	42050030	30	1F	90,96	90,20	97	70	19	32	11	68	1,17
32 L 050	42050032	32	1F	97,03	96,26	102	70	19	32	11	70	1,41
33 L 050	42050033	33	1F	100,05	99,29	106	70	19	32	11	71	1,49
34 L 050	42050034	34	1F	103,08	102,32	112	70	19	32	11	72	1,57
35 L 050	42050035	35	1F	106,12	105,35	112	70	19	32	11	72	1,62
36 L 050	42050036	36	1F	109,14	108,39	115	70	19	32	11	74	1,7
40 L 050	42050040	40	1F	121,29	120,51	128	70	19	32	11	78	2,03
42 L 050	42050042	42	1F	127,34	126,57	135	70	19	32	11	80	2,21
44 L 050	42050044	44	1F	133,4	132,64	142	70	19	32	11	81	2,38
45 L 050	42050045	45	1F	136,44	135,67	142	70	19	32	11	81	2,48
48 L 050	42050048	48	1F	145,54	144,77	150	70	19	32	11	85	2,78
50 L 050	42050050	50	4	151,6	150,83	-	70	19	32	14	-	1,74
52 L 050	42050052	52	4	157,66	156,9	-	70	19	32	14	-	1,8
56 L 050	42050056	56	4	169,79	169,02	-	70	19	32	14	-	1,87
57 L 050	42050057	57	4	172,82	172,06	-	70	19	32	14	-	1,88
60 L 050	42050060	60	4	181,92	181,15	-	75	19	42	14	-	2,41
72 L 050	42050072	72	4	218,29	217,53	-	75	19	42	14	-	2,82
84 L 050	42050084	84	4	254,69	253,92	-	75	19	42	14	-	3,08
96 L 050	42050096	96	4	291,06	290,3	-	75	19	42	14	-	3,42

MATERIAL **STEEL**
C 45

MATERIAL **CAST-IRON**

CAD drawings available on our site
www.chiaravalli.com

Quantity, availability and prices
on B2B Chiaravalli

TIMING PULLEYS with PILOT BORE TYPE L 050

7

The images do not identify the products.



FOR POSITIVE BELTS

TYPE **L 075**

PITCH 3/8" (9.52 mm)

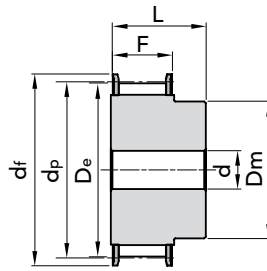
Different pitch of teeth
available on request.

EXEC. 1F

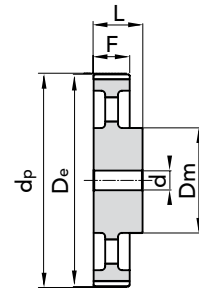

EXEC. 4

TYPE	P. NUMBER	N. TEETH	EXEC.	Dp	De	Df FLANGE	Dm HUB	F	L	d	N. FLANGE	WEIGHT kg.
10 L 075	42075010	10	1F	30,33	29,56	37	20	25,4	38	8	50	0,14
11 L 075	42075011	11	1F	33,35	32,59	37	22	25,4	38	8	50	0,18
12 L 075	42075012	12	1F	36,37	35,62	43	24	25,4	38	8	52	0,22
13 L 075	42075013	13	1F	39,41	38,65	44	28	25,4	38	8	83	0,26
14 L 075	42075014	14	1F	42,44	41,68	48	28	25,4	38	11	54	0,30
15 L 075	42075015	15	1F	45,48	44,72	51	34	25,4	38	11	55	0,37
16 L 075	42075016	16	1F	48,51	47,75	54	36	25,4	38	11	56	0,43
17 L 075	42075017	17	1F	51,54	50,78	57	36	25,4	38	11	57	0,46
18 L 075	42075018	18	1F	54,59	53,81	60	40	25,4	38	11	58	0,54
19 L 075	42075019	19	1F	57,61	56,84	64	40	25,4	38	11	59	0,58
20 L 075	42075020	20	1F	60,63	59,88	66,5	40	25,4	38	11	60	0,64
21 L 075	42075021	21	1F	63,68	62,91	70	45	25,4	38	11	61	0,71
22 L 075	42075022	22	1F	66,70	65,94	75	45	25,4	38	11	62	0,79
23 L 075	42075023	23	1F	69,73	68,97	79	55	25,4	38	11	63	0,94
24 L 075	42075024	24	1F	72,77	72,00	79	55	25,4	38	11	63	1,00
25 L 075	42075025	25	1F	75,80	75,04	82,5	58	25,4	38	11	64	1,10
26 L 075	42075026	26	1F	78,84	78,07	86	58	25,4	38	11	65	1,16
27 L 075	42075027	27	1F	81,86	81,10	86	58	25,4	38	11	65	1,22
28 L 075	42075028	28	1F	84,89	84,13	91	58	25,4	38	11	66	1,30
30 L 075	42075030	30	1F	90,96	90,20	97	70	25,4	38	11	68	1,47
32 L 075	42075032	32	1F	97,03	96,26	102	70	25,4	38	11	70	1,75
33 L 075	42075033	33	1F	100,05	99,29	106	70	25,4	38	11	71	1,85
34 L 075	42075034	34	1F	103,08	102,32	112	70	25,4	38	11	72	1,93
35 L 075	42075035	35	1F	106,12	105,35	112	70	25,4	38	11	72	2,03
36 L 075	42075036	36	1F	109,14	108,39	115	70	25,4	38	11	74	2,14
40 L 075	42075040	40	1F	121,29	120,51	128	70	25,4	38	11	78	2,56
42 L 075	42075042	42	1F	127,34	126,57	135	70	25,4	38	11	80	2,81
44 L 075	42075044	44	1F	133,4	132,64	142	70	25,4	38	11	81	3,02
45 L 075	42075045	45	1F	136,44	135,67	142	70	25,4	38	11	81	3,16
48 L 075	42075048	48	1F	145,54	144,77	150	70	25,4	38	11	85	3,57
50 L 075	42075050	50	4	151,6	150,83	-	70	25,4	38	14	-	2,10
52 L 075	42075052	52	4	157,66	156,9	-	70	25,4	38	14	-	2,13
56 L 075	42075056	56	4	169,79	169,02	-	70	25,4	38	14	-	2,27
57 L 075	42075057	57	4	172,82	172,06	-	70	25,4	38	14	-	2,28
60 L 075	42075060	60	4	181,92	181,15	-	75	25,4	45	14	-	2,70
72 L 075	42075072	72	4	218,29	217,53	-	75	25,4	45	14	-	3,19
84 L 075	42075084	84	4	254,69	253,92	-	75	25,4	45	14	-	3,64
96 L 075	42075096	96	4	291,06	290,3	-	75	25,4	45	14	-	4,04

MATERIAL **STEEL**
C 45MATERIAL **CAST-IRON**CAD drawings available on our site
www.chiaravalli.comQuantity, availability and prices
on B2B Chiaravalli



TIMING PULLEYS with PILOT BORE

FOR POSITIVE BELTS

TYPE L 100

PITCH 3/8" (9.52 mm)

Different pitch of teeth available on request.

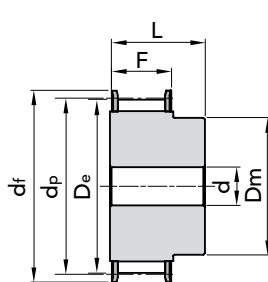

EXEC. 1F

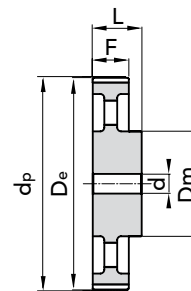

EXEC. 4

TYPE	P. NUMBER	N. TEETH	EXEC.	Dp	De	Df FLANGE	Dm HUB	F	L	d	N. FLANGE	WEIGHT kg.
10 L 100	42100010	10	1F	30,33	29,56	37	20	31,8	45	8	50	0,17
11 L 100	42100011	11	1F	33,35	32,59	37	22	31,8	45	8	50	0,22
12 L 100	42100012	12	1F	36,37	35,62	43	24	31,8	45	8	52	0,26
13 L 100	42100013	13	1F	39,41	38,65	44	28	31,8	45	8	83	0,32
14 L 100	42100014	14	1F	42,44	41,68	48	28	31,8	45	11	54	0,35
15 L 100	42100015	15	1F	45,48	44,72	51	34	31,8	45	11	55	0,43
16 L 100	42100016	16	1F	48,51	47,75	54	36	31,8	45	11	56	0,50
17 L 100	42100017	17	1F	51,54	50,78	57	36	31,8	45	11	57	0,56
18 L 100	42100018	18	1F	54,59	53,81	60	40	31,8	45	11	58	0,64
19 L 100	42100019	19	1F	57,61	56,84	64	40	31,8	45	11	59	0,70
20 L 100	42100020	20	1F	60,63	59,88	66	40	31,8	45	11	60	0,77
21 L 100	42100021	21	1F	63,68	62,91	70	45	31,8	45	11	61	0,88
22 L 100	42100022	22	1F	66,70	65,94	75	45	31,8	45	11	62	0,95
23 L 100	42100023	23	1F	69,73	68,97	79	55	31,8	45	11	63	1,11
24 L 100	42100024	24	1F	72,77	72,00	79	55	31,8	45	11	63	1,18
25 L 100	42100025	25	1F	75,80	75,04	82	58	31,8	45	11	64	1,30
26 L 100	42100026	26	1F	78,84	78,07	86	58	31,8	45	11	65	1,40
27 L 100	42100027	27	1F	81,86	81,10	86	58	31,8	45	11	65	1,47
28 L 100	42100028	28	1F	84,89	84,13	91	58	31,8	45	11	66	1,58
30 L 100	42100030	30	1F	90,96	90,20	97	70	31,8	45	11	68	1,78
32 L 100	42100032	32	1F	97,03	96,26	102	70	31,8	45	11	70	2,11
33 L 100	42100033	33	1F	100,05	99,29	106	70	31,8	45	11	71	2,23
34 L 100	42100034	34	1F	103,08	102,32	112	70	31,8	45	11	72	2,39
35 L 100	42100035	35	1F	106,12	105,35	112	70	31,8	45	11	72	2,45
36 L 100	42100036	36	1F	109,14	108,39	115	70	31,8	45	11	74	2,59
40 L 100	42100040	40	1F	121,29	120,51	128	70	31,8	45	11	78	3,13
42 L 100	42100042	42	1F	127,34	126,57	135	70	31,8	45	11	80	3,43
44 L 100	42100044	44	1F	133,4	132,64	142	70	31,8	45	11	81	3,72
45 L 100	42100045	45	1F	136,44	135,67	142	70	31,8	45	11	81	3,89
48 L 100	42100048	48	1F	145,54	144,77	150	70	31,8	45	11	85	4,38
50 L 100	42100050	50	4	151,6	150,83	-	70	31,8	45	14	-	2,41
52 L 100	42100052	52	4	157,66	156,9	-	70	31,8	45	14	-	2,55
56 L 100	42100056	56	4	169,79	169,02	-	70	31,8	45	14	-	2,65
57 L 100	42100057	57	4	172,82	172,06	-	70	31,8	45	14	-	2,71
60 L 100	42100060	60	4	181,92	181,15	-	75	31,8	45	14	-	3,11
72 L 100	42100072	72	4	218,29	217,53	-	75	31,8	45	14	-	3,65
84 L 100	42100084	84	4	254,69	253,92	-	75	31,8	45	14	-	4,12
96 L 100	42100096	96	4	291,06	290,3	-	75	31,8	45	14	-	4,60

MATERIAL **STEEL**
C 45

MATERIAL **CAST-IRON**

CAD drawings available on our site
www.chiaravalli.com

Quantity, availability and prices on B2B Chiaravalli



The images do not identify the products.

TIMING PULLEYS with PILOT BORE TYPE L 100



FOR POSITIVE BELTS

TYPE **H 075**

PITCH 1/2" (12.7 mm)

Different pitch of teeth available on request.

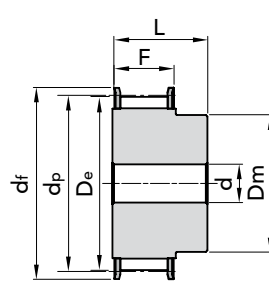

EXEC. 1F

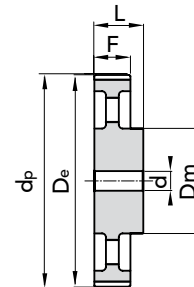

EXEC. 4

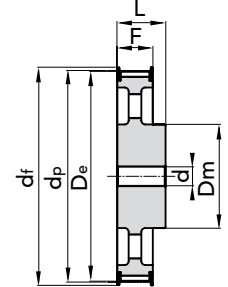

EXEC. 5F

TIMING PULLEYS with PILOT BORE TYPE H 075

TYPE	P. NUMBER	N. TEETH	EXEC.	Dp	De	Df FLANGE	Dm HUB	F	L	d	N. FLANGE	WEIGHT kg.
14 H 075	43075014	14	1F	56,59	55,22	64	40	26,4	40	-	59	0,58
15 H 075	43075015	15	1F	60,64	59,27	66,5	45	26,4	40	-	60	0,69
16 H 075	43075016	16	1F	64,67	63,31	70	45	26,4	40	-	61	0,77
17 H 075	43075017	17	1F	68,72	67,35	75	45	26,4	40	-	62	0,84
18 H 075	43075018	18	1F	72,77	71,39	79	55	26,4	40	-	63	1,01
19 H 075	43075019	19	1F	76,81	75,44	82,5	60	26,4	40	11	64	1,15
20 H 075	43075020	20	1F	80,85	79,48	87	62	26,4	40	11	76	1,27
21 H 075	43075021	21	1F	84,89	83,52	91	65	26,4	40	11	66	1,41
22 H 075	43075022	22	1F	88,93	87,56	94	68	26,4	40	11	67	1,55
23 H 075	43075023	23	1F	92,98	91,61	97	72	26,4	40	11	68	1,71
24 H 075	43075024	24	1F	97,03	95,65	102	72	26,4	40	11	70	1,83
25 H 075	43075025	25	1F	101,06	99,69	106	72	26,4	40	11	71	1,96
26 H 075	43075026	26	1F	105,11	103,73	112	80	26,4	40	11	72	2,19
27 H 075	43075027	27	1F	109,15	107,78	115	80	26,4	40	11	74	2,32
28 H 075	43075028	28	1F	113,18	111,82	120	80	26,4	40	11	75	2,47
30 H 075	43075030	30	1F	121,29	119,90	128	80	26,4	40	11	78	2,76
32 H 075	43075032	32	1F	129,30	127,99	135	80	26,4	40	11	80	3,08
33 H 075	43075033	33	1F	133,40	132,03	142	80	26,4	40	11	81	3,25
34 H 075	43075034	34	1F	137,45	136,07	142	80	26,4	40	11	81	3,42
35 H 075	43075035	35	1F	141,49	140,12	150	80	26,4	40	11	85	3,61
36 H 075	43075036	36	1F	145,54	144,16	150	80	26,4	40	11	85	3,79
38 H 075	43075038	38	1F	153,62	152,24	158	80	26,4	40	11	86	4,16
40 H 075	43075040	40	1F	161,70	160,33	168	80	26,4	40	11	90	4,58
42 H 075	43075042	42	1F	169,79	168,41	184	80	26,4	40	11	94	5,05
44 H 075	43075044	44	5F	177,80	176,50	184	80	26,4	40	14	95	2,57
48 H 075	43075048	48	5F	194,03	192,67	200	90	26,4	45	14	100	3,56
50 H 075	43075050	50	4	202,13	200,75	-	90	26,4	45	14	-	3,74

MATERIAL **STEEL**
C 45MATERIAL **CAST-IRON**CAD drawings available on our site
www.chiaravalli.comQuantity, availability and prices
on B2B Chiaravalli



TIMING PULLEYS with PILOT BORE

FOR POSITIVE BELTS

TYPE H 100

PITCH 1/2" (12.7 mm)

Different pitch of teeth available on request.

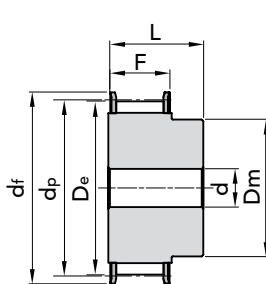

EXEC. 1F

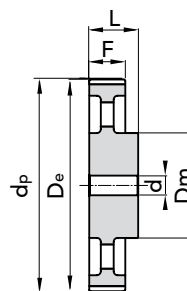

EXEC. 4

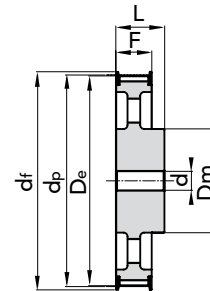

EXEC. 5F

TYPE	P. NUMBER	N. TEETH	EXEC.	Dp	De	Df FLANGE	Dm HUB	F	L	d	N. FLANGE	WEIGHT kg.
14 H 100	43100014	14	1F	56,59	55,22	64	40	31,8	45	-	59	0,65
15 H 100	43100015	15	1F	60,64	59,27	66,5	45	31,8	45	-	60	0,77
16 H 100	43100016	16	1F	64,67	63,31	70	45	31,8	45	-	61	0,87
17 H 100	43100017	17	1F	68,72	67,35	75	45	31,8	45	-	62	0,97
18 H 100	43100018	18	1F	72,77	71,39	79	55	31,8	45	-	63	1,16
19 H 100	43100019	19	1F	76,81	75,44	82,5	60	31,8	45	14	64	1,30
20 H 100	43100020	20	1F	80,85	79,48	87	62	31,8	45	14	76	1,44
21 H 100	43100021	21	1F	84,89	83,52	91	65	31,8	45	14	66	1,60
22 H 100	43100022	22	1F	88,93	87,56	94	68	31,8	45	14	67	1,76
23 H 100	43100023	23	1F	92,98	91,61	97	72	31,8	45	14	68	1,94
24 H 100	43100024	24	1F	97,03	95,65	102	72	31,8	45	14	70	2,09
25 H 100	43100025	25	1F	101,06	99,69	106	72	31,8	45	14	71	2,24
26 H 100	43100026	26	1F	105,11	103,73	112	80	31,8	45	14	72	2,49
27 H 100	43100027	27	1F	109,15	107,78	115	80	31,8	45	14	74	2,66
28 H 100	43100028	28	1F	113,18	111,82	120	80	31,8	45	14	75	2,83
29 H 100	43100029	29	1F	117,23	115,86	120	80	31,8	45	14	75	3,01
30 H 100	43100030	30	1F	121,29	119,90	128	80	31,8	45	14	78	3,19
32 H 100	43100032	32	1F	129,30	127,99	135	80	31,8	45	14	80	3,57
33 H 100	43100033	33	1F	133,40	132,03	142	80	31,8	45	14	81	3,79
34 H 100	43100034	34	1F	137,45	136,07	142	80	31,8	45	14	81	3,99
35 H 100	43100035	35	1F	141,49	140,12	150	80	31,8	45	14	85	4,20
36 H 100	43100036	36	1F	145,54	144,16	150	80	31,8	45	14	85	4,44
38 H 100	43100038	38	1F	153,62	152,24	158	80	31,8	45	14	86	4,90
40 H 100	43100040	40	1F	161,70	160,33	168	80	31,8	45	14	90	5,39
42 H 100	43100042	42	1F	169,79	168,41	180	80	31,8	45	14	94	5,89
44 H 100	43100044	44	5F	177,88	176,50	184	80	31,8	50	14	95	3,37
45 H 100	43100045	45	5F	181,91	180,54	192	80	31,8	50	14	96	3,57
48 H 100	43100048	48	5F	194,03	192,67	200	90	31,8	50	14	100	4,10
50 H 100	43100050	50	4	202,13	200,75	-	90	31,8	50	19	-	4,24
52 H 100	43100052	52	4	210,21	208,84	-	90	31,8	50	19	-	4,32
58 H 100	43100058	58	4	234,47	233,09	-	90	31,8	50	19	-	4,61
60 H 100	43100060	60	4	242,55	241,18	-	120	31,8	50	19	-	5,30
70 H 100	43100070	70	4	282,98	281,61	-	120	31,8	55	19	-	6,13
72 H 100	43100072	72	4	291,06	289,69	-	120	31,8	55	19	-	7,47
84 H 100	43100084	84	4	339,57	338,2	-	120	31,8	55	19	-	8,52
96 H 100	43100096	96	4	388,09	386,71	-	120	31,8	60	19	-	10,25
120 H 100	43100120	120	4	485,12	483,73	-	120	31,8	60	19	-	13,09

MATERIAL **STEEL**
C 45

MATERIAL **CAST-IRON**

CAD drawings available on our site
www.chiaravalli.com

Quantity, availability and prices
on B2B Chiaravalli





FOR POSITIVE BELTS

TYPE **H 150**

PITCH 1/2" (12.7 mm)

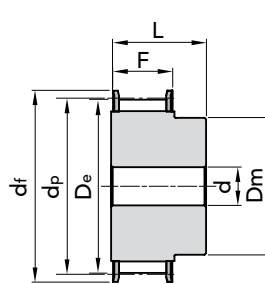
Different pitch of teeth
available on request.

EXEC. 1F

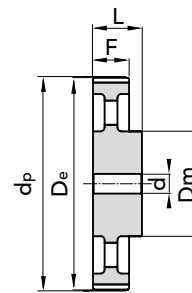

EXEC. 4

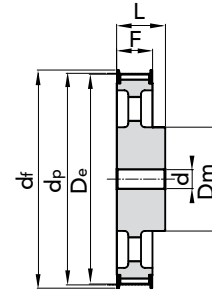

EXEC. 5F

TYPE	P. NUMBER	N. TEETH	EXEC.	Dp	De	Df FLANGE	Dm HUB	F	L	d	N. FLANGE	WEIGHT kg.
14 H 150	43150014	14	1F	56,59	55,22	64	42	46,0	58	-	59	0,81
15 H 150	43150015	15	1F	60,64	59,27	66,5	45	46,0	58	-	60	0,97
16 H 150	43150016	16	1F	64,67	63,31	70	45	46,0	58	-	61	1,11
17 H 150	43150017	17	1F	68,72	67,35	75	45	46,0	58	-	62	1,25
18 H 150	43150018	18	1F	72,77	71,39	79	55	46,0	58	-	63	1,48
19 H 150	43150019	19	1F	76,81	75,44	82,5	60	46,0	58	-	64	1,68
20 H 150	43150020	20	1F	80,85	79,48	87	62	46,0	58	-	76	1,88
21 H 150	43150021	21	1F	84,89	83,52	91	65	46,0	58	-	66	2,08
22 H 150	43150022	22	1F	88,93	87,56	94	68	46,0	58	-	67	2,30
23 H 150	43150023	23	1F	92,98	91,61	97	72	46,0	58	-	68	2,54
24 H 150	43150024	24	1F	97,03	95,65	102	72	46,0	58	-	70	2,75
25 H 150	43150025	25	1F	101,06	99,69	106	72	46,0	58	-	71	2,97
26 H 150	43150026	26	1F	105,11	103,73	112	80	46,0	58	-	72	3,29
27 H 150	43150027	27	1F	109,15	107,78	115	80	46,0	58	-	74	3,52
28 H 150	43150028	28	1F	113,18	111,82	120	80	46,0	58	-	75	3,78
29 H 150	43150029	29	1F	117,23	115,86	120	80	46,0	58	-	75	4,03
30 H 150	43150030	30	1F	121,29	119,90	128	80	46,0	58	-	78	4,29
32 H 150	43150032	32	1F	129,30	127,99	135	80	46,0	58	-	80	4,86
33 H 150	43150033	33	1F	133,40	132,03	142	80	46,0	58	-	81	5,15
34 H 150	43150034	34	1F	137,45	136,07	142	80	46,0	58	-	81	5,46
35 H 150	43150035	35	1F	141,49	140,12	150	80	46,0	58	-	85	5,78
36 H 150	43150036	36	1F	145,54	144,16	150	80	46,0	58	-	85	6,09
38 H 150	43150038	38	1F	153,62	152,24	158	80	46,0	58	-	86	6,74
40 H 150	43150040	40	1F	161,70	160,33	168	80	46,0	58	-	90	7,46
42 H 150	43150042	42	1F	169,79	168,41	180	80	46,0	58	-	94	7,98
44 H 150	43150044	44	5F	177,88	176,50	184	80	46,0	58	19	95	4,29
45 H 150	43150045	45	5F	181,91	180,54	192	80	46,0	58	19	96	4,44
48 H 150	43150048	48	5F	194,03	192,67	200	90	46,0	65	19	100	5,41
50 H 150	43150050	50	4	202,13	200,75	-	90	46,0	65	19	-	5,59
52 H 150	43150052	52	4	210,21	208,84	-	90	46,0	65	19	-	5,79
58 H 150	43150058	58	4	234,47	233,09	-	90	46,0	65	19	-	6,15
60 H 150	43150060	60	4	242,55	241,18	-	120	46,0	65	19	-	7,08
70 H 150	43150070	70	4	282,98	281,61	-	120	46,0	65	24	-	7,77
72 H 150	43150072	72	4	291,06	289,69	-	120	46,0	65	24	-	9,70
84 H 150	43150084	84	4	339,57	338,2	-	120	46,0	65	24	-	10,99
96 H 150	43150096	96	4	388,09	386,71	-	120	46,0	65	24	-	12,24
120 H 150	43150120	120	4	485,12	483,73	-	120	46,0	65	24	-	16,17

MATERIAL **STEEL**
C 45MATERIAL **CAST-IRON**CAD drawings available on our site
www.chiaravalli.comQuantity, availability and prices
on B2B Chiaravalli



FOR POSITIVE BELTS

TYPE H 200

PITCH 1/2" (12.7 mm)

Different pitch of teeth available on request.

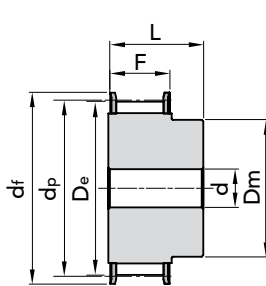

EXEC. 1F

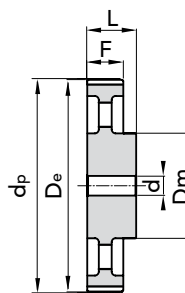

EXEC. 4

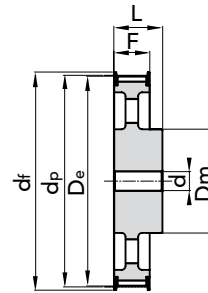

EXEC. 5F

TYPE	P. NUMBER	N. TEETH	EXEC.	Dp	De	Df FLANGE	Dm HUB	F	L	d	N. FLANGE	WEIGHT kg.
14 H 200	43200014	14	1F	56,59	55,22	64	40	58,7	70	-	59	1,10
15 H 200	43200015	15	1F	60,64	59,27	66,5	45	58,7	70	-	60	1,33
16 H 200	43200016	16	1F	64,67	63,31	70	45	58,7	70	-	61	1,54
17 H 200	43200017	17	1F	68,72	67,35	75	45	58,7	70	-	62	1,69
18 H 200	43200018	18	1F	72,77	71,39	79	55	58,7	70	-	63	1,95
19 H 200	43200019	19	1F	76,81	75,44	82,5	60	58,7	70	-	64	2,20
20 H 200	43200020	20	1F	80,85	79,48	87	62	58,7	70	-	76	2,44
21 H 200	43200021	21	1F	84,89	83,52	91	65	58,7	70	-	66	2,70
22 H 200	43200022	22	1F	88,93	87,56	94	68	58,7	70	-	67	2,97
23 H 200	43200023	23	1F	92,98	91,61	97	72	58,7	70	-	68	3,25
24 H 200	43200024	24	1F	97,03	95,65	102	72	58,7	70	-	70	3,56
25 H 200	43200025	25	1F	101,06	99,69	106	72	58,7	70	-	71	3,81
26 H 200	43200026	26	1F	105,11	103,73	112	80	58,7	70	-	72	4,18
27 H 200	43200027	27	1F	109,15	107,78	115	80	58,7	70	-	74	4,49
28 H 200	43200028	28	1F	113,18	111,82	120	80	58,7	70	-	75	4,81
29 H 200	43200029	29	1F	117,23	115,86	120	80	58,7	70	-	75	5,14
30 H 200	43200030	30	1F	121,29	119,90	128	80	58,7	70	-	78	5,47
32 H 200	43200032	32	1F	129,30	127,99	135	80	58,7	70	-	80	6,17
33 H 200	43200033	33	1F	133,40	132,03	142	80	58,7	70	-	81	6,56
34 H 200	43200034	34	1F	137,45	136,07	142	80	58,7	70	-	81	6,94
35 H 200	43200035	35	1F	141,49	140,12	150	80	58,7	70	-	85	7,34
36 H 200	43200036	36	1F	145,54	144,16	150	80	58,7	70	-	85	7,75
38 H 200	43200038	38	1F	153,62	152,24	158	80	58,7	70	-	86	8,62
40 H 200	43200040	40	1F	161,70	160,33	168	80	58,7	70	-	90	9,50
42 H 200	43200042	42	1F	169,79	168,41	180	80	58,7	70	-	94	10,61
44 H 200	43200044	44	5F	177,88	176,50	184	80	58,7	70	19	95	5,14
45 H 200	43200045	45	5F	181,91	180,54	192	80	58,7	70	19	96	5,38
48 H 200	43200048	48	5F	194,03	192,67	200	90	58,7	75	24	100	6,29
50 H 200	43200050	50	4	202,13	200,75	-	90	58,7	75	24	-	6,68
52 H 200	43200052	52	4	210,21	208,84	-	90	58,7	75	24	-	6,81
58 H 200	43200058	58	4	234,47	233,09	-	90	58,7	75	24	-	7,26
60 H 200	43200060	60	4	242,55	241,18	-	120	58,7	75	24	-	8,25
70 H 200	43200070	70	4	282,98	281,61	-	120	58,7	75	28	-	9,20
72 H 200	43200072	72	4	291,06	289,69	-	120	58,7	75	28	-	11,09
84 H 200	43200084	84	4	339,57	338,2	-	120	58,7	75	28	-	12,63
96 H 200	43200096	96	4	388,09	386,71	-	120	58,7	75	28	-	14,51
120 H 200	43200120	120	4	485,12	483,73	-	120	58,7	75	28	-	19,15

MATERIAL **STEEL**
C 45

MATERIAL **CAST-IRON**

CAD drawings available on our site
www.chiaravalli.com

Quantity, availability and prices
on B2B Chiaravalli



The images do not identify the products.

TIMING PULLEYS with PILOT BORE TYPE H 200



FOR POSITIVE BELTS

TYPE **H 300**

PITCH 1/2" (12.7 mm)

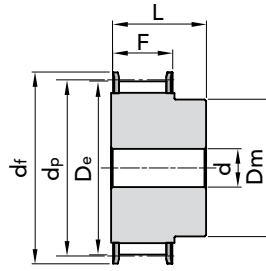
Different pitch of teeth
available on request.

EXEC. 1F

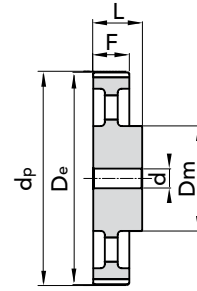

EXEC. 4

TYPE	P. NUMBER	N. TEETH	EXEC.	Dp	De	Df FLANGE	Dm HUB	F	L	d	N. FLANGE	WEIGHT kg.
14 H 300	43300014	14	1F	56,59	55,22	64	42	85,7	100	-	59	1,64
15 H 300	43300015	15	1F	60,64	59,27	66,5	45	85,7	100	-	60	1,91
16 H 300	43300016	16	1F	64,67	63,31	70	45	85,7	100	-	61	2,16
17 H 300	43300017	17	1F	68,72	67,35	75	45	85,7	100	-	62	2,43
18 H 300	43300018	18	1F	72,77	71,39	79	55	85,7	100	-	63	2,80
19 H 300	43300019	19	1F	76,81	75,44	82,5	60	85,7	100	-	64	3,16
20 H 300	43300020	20	1F	80,85	79,48	87	62	85,7	100	-	76	3,50
21 H 300	43300021	21	1F	84,89	83,52	91	65	85,7	100	-	66	3,87
22 H 300	43300022	22	1F	88,93	87,56	94	68	85,7	100	-	67	4,26
23 H 300	43300023	23	1F	92,98	91,61	97	72	85,7	100	-	68	4,68
24 H 300	43300024	24	1F	97,03	95,65	102	72	85,7	100	-	70	5,08
25 H 300	43300025	25	1F	101,06	99,69	106	72	85,7	100	-	71	5,45
26 H 300	43300026	26	1F	105,11	103,73	112	80	85,7	100	-	72	6,01
27 H 300	43300027	27	1F	109,15	107,78	115	80	85,7	100	-	74	6,45
28 H 300	43300028	28	1F	113,18	111,82	120	80	85,7	100	-	75	6,91
30 H 300	43300030	30	1F	121,29	119,90	128	80	85,7	100	-	78	7,90
32 H 300	43300032	32	1F	129,30	127,99	135	80	85,7	100	-	80	8,92
33 H 300	43300033	33	1F	133,40	132,03	142	80	85,7	100	-	81	9,46
34 H 300	43300034	34	1F	137,45	136,07	142	80	85,7	100	-	81	10,04
35 H 300	43300035	35	1F	141,49	140,12	150	80	85,7	100	-	85	10,62
36 H 300	43300036	36	1F	145,54	144,16	150	80	85,7	100	-	85	11,24
38 H 300	43300038	38	1F	153,62	152,24	158	80	85,7	100	-	86	12,44
40 H 300	43300040	40	1F	161,70	160,33	168	80	85,7	100	-	90	13,80
42 H 300	43300042	42	1F	169,79	168,41	180	80	85,7	100	-	94	15,27
44 H 300	43300044	44	4	177,88	176,50	-	80	85,7	100	24	-	7,22
48 H 300	43300048	48	4	194,03	192,67	-	90	85,7	100	24	-	8,60
50 H 300	43300050	50	4	202,13	200,75	-	90	85,7	100	24	-	8,99
58 H 300	43300058	58	4	234,47	233,09	-	90	85,7	100	24	-	10,04
70 H 300	43300060	70	4	242,55	241,18	-	120	85,7	100	24	-	11,18
72 H 300	43300072	72	4	291,06	289,69	-	120	85,7	100	28	-	15,07
84 H 300	43300084	84	4	339,57	338,2	-	120	85,7	100	28	-	16,97
96 H 300	43300096	96	4	388,09	386,71	-	120	85,7	100	28	-	19,86
120 H 300	43300120	120	4	485,12	483,73	-	120	85,7	100	28	-	25,91

MATERIAL **STEEL**
C 45MATERIAL **CAST-IRON**CAD drawings available on our site
www.chiaravalli.comQuantity, availability and prices
on B2B Chiaravalli



FOR POSITIVE BELTS

TYPE **XH 200**

PITCH 7/8" (22.22 mm)

Different pitch of teeth available on request.

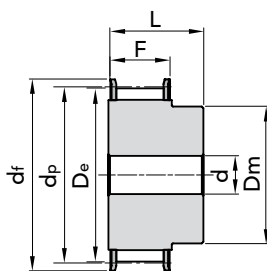

EXEC. 1F

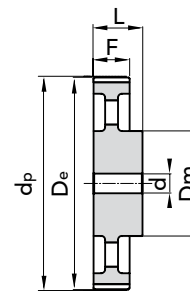

EXEC. 4

TYPE	P. NUMBER	N. TEETH	EXEC.	Dp	De	Df FLANGE	Dm HUB	F	L	d	N. FLANGE	WEIGHT kg.
18 XH 200	44200018	18	1F	127,34	124,55	140	100	65,0	80	24	155	6,00
19 XH 200	44200019	19	1F	134,41	131,62	146	100	65,0	80	24	156	6,60
20 XH 200	44200020	20	1F	141,49	138,69	155	100	65,0	80	24	157	7,30
21 XH 200	44200021	21	1F	148,56	145,77	160	110	65,0	80	24	158	8,73
22 XH 200	44200022	22	1F	155,64	152,84	170	110	65,0	80	24	159	9,55
24 XH 200	44200024	24	1F	169,79	166,99	184	120	65,0	80	24	161	11,47
25 XH 200	44200025	25	1F	176,86	174,07	188	120	65,0	80	24	162	12,46
26 XH 200	44200026	26	1F	183,93	181,14	198	120	65,0	80	24	163	13,47
27 XH 200	44200027	27	1F	191,01	188,22	205	120	65,0	80	24	164	14,42
28 XH 200	44200028	28	1F	198,09	195,29	212	120	65,0	80	24	165	15,44
30 XH 200	44200030	30	1F	212,23	209,44	227	120	65,0	80	24	167	17,69
32 XH 200	44200032	32	1F	226,38	223,59	240	120	65,0	80	24	169	19,95
34 XH 200	44200034	34	1F	240,53	237,74	256	120	65,0	80	24	170	22,75

MATERIAL **STEEL**
C 45

CAD drawings available on our site
www.chiaravalli.com

Quantity, availability and prices
on B2B Chiaravalli



The images do not identify the products.



FOR POSITIVE BELTS

TYPE **XH 300**

PITCH 7/8" (22.22 mm)

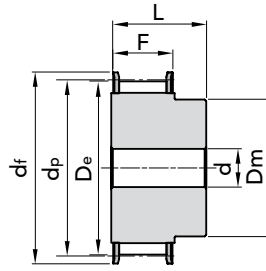
Different pitch of teeth
available on request.

EXEC. 1F

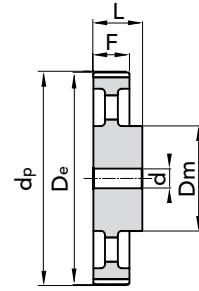

EXEC. 4

TYPE	P. NUMBER	N. TEETH	EXEC.	Dp	De	Df FLANGE	Dm HUB	F	L	d	N. FLANGE	WEIGHT kg.
18 XH 300	44300018	18	1F	127,34	124,55	140	100	90,5	110	28	155	8,90
19 XH 300	44300019	19	1F	134,41	131,62	146	100	90,5	110	28	156	9,20
20 XH 300	44300020	20	1F	141,49	138,69	155	100	90,5	110	28	157	10,61
21 XH 300	44300021	21	1F	148,56	145,77	160	110	90,5	110	28	158	11,87
22 XH 300	44300022	22	1F	155,64	152,84	170	110	90,5	110	28	159	13,08
24 XH 300	44300024	24	1F	169,79	166,99	184	120	90,5	110	28	161	15,77
25 XH 300	44300025	25	1F	176,86	174,07	188	120	90,5	110	28	162	17,13
26 XH 300	44300026	26	1F	183,93	181,14	198	120	90,5	110	28	163	18,55
27 XH 300	44300027	27	1F	191,01	188,22	205	120	90,5	110	28	164	19,90
28 XH 300	44300028	28	1F	198,09	195,29	212	150	90,5	110	28	165	22,27
30 XH 300	44300030	30	1F	212,23	209,44	227	150	90,5	110	28	167	25,39
32 XH 300	44300032	32	1F	226,38	223,59	240	150	90,5	110	28	169	28,73
34 XH 300	44300034	34	1F	240,53	237,74	256	150	90,5	110	28	170	34,20

MATERIAL **STEEL**
C 45CAD drawings available on our site
www.chiaravalli.comQuantity, availability and prices
on B2B Chiaravalli



TIMING PULLEYS with PILOT BORE

FOR POSITIVE BELTS

TYPE **XH 400**

PITCH 7/8" (22.22 mm)

Different pitch of teeth available on request.

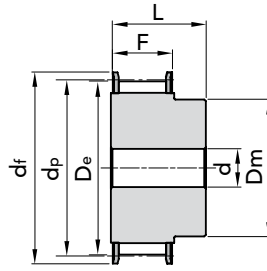

EXEC. 1F

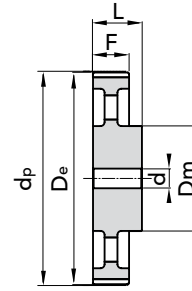

EXEC. 4

TYPE	P. NUMBER	N. TEETH	EXEC.	Dp	De	Df FLANGE	Dm HUB	F	L	d	N. FLANGE	WEIGHT kg.
18 XH 400	44400018	18	1F	127,34	124,55	140	100	118,0	132	32	155	9,60
19 XH 400	44400019	19	1F	134,41	131,62	146	100	118,0	132	32	156	10,80
20 XH 400	44400020	20	1F	141,49	138,69	155	100	118,0	132	32	157	12,87
21 XH 400	44400021	21	1F	148,56	145,77	160	110	118,0	132	32	158	14,42
22 XH 400	44400022	22	1F	155,64	152,84	170	110	118,0	132	32	159	15,44
24 XH 400	44400024	24	1F	169,79	166,99	184	120	118,0	132	32	161	19,22
25 XH 400	44400025	25	1F	176,86	174,07	188	120	118,0	132	32	162	21,05
26 XH 400	44400026	26	1F	183,93	181,14	198	120	118,0	132	32	163	22,80
27 XH 400	44400027	27	1F	191,01	188,22	205	120	118,0	132	32	164	24,66
28 XH 400	44400028	28	1F	198,09	195,29	212	150	118,0	132	32	165	27,23
30 XH 400	44400030	30	1F	212,23	209,44	227	150	118,0	132	32	167	31,30
32 XH 400	44400032	32	1F	226,38	223,59	240	150	118,0	132	32	169	35,20
34 XH 400	44400034	34	1F	240,53	237,74	256	150	118,0	132	32	170	40,00

MATERIAL **STEEL**
C 45

CAD drawings available on our site
www.chiaravalli.com

Quantity, availability and prices on B2B Chiaravalli



The images do not identify the products.

TIMING PULLEYS with PILOT BORE TYPE XH 400



FOR POSITIVE BELTS

TYPE **XXH 200**

PITCH 1" 1/4 (31.75 mm)

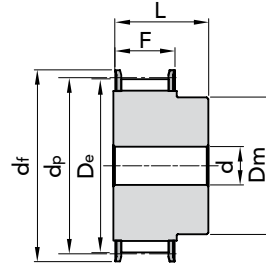
Different pitch of teeth
available on request.

EXEC. 1F

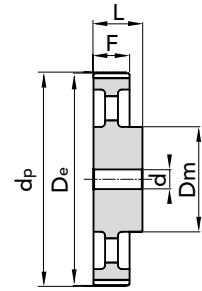

EXEC. 4

TYPE	P. NUMBER	N. TEETH	EXEC.	Dp	De	Df FLANGE	Dm HUB	F	L	d	N. FLANGE	WEIGHT kg.
18 XXH 200	44600018	18	1F	181,91	178,87	198	140	64,2	100	28	163	22,92
20 XXH 200	44600020	20	1F	202,13	199,08	212	150	64,2	100	28	165	28,00
22 XXH 200	44600022	22	1F	222,34	219,29	240	150	64,2	100	28	169	33,60
24 XXH 200	44600024	24	1F	242,55	239,50	267	150	64,2	100	28	173	39,70
26 XXH 200	44600026	26	1F	262,76	259,79	290	150	64,2	100	28	178	45,85

FOR POSITIVE BELTS

TYPE **XXH 300**

PITCH 1" 1/4 (31.75 mm)

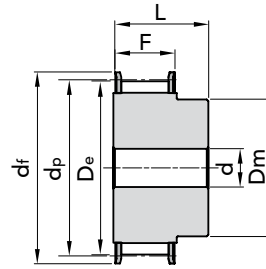
Different pitch of teeth
available on request.

EXEC. 1F

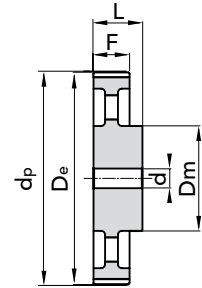

EXEC. 4

TYPE	P. NUMBER	N. TEETH	EXEC.	Dp	De	Df FLANGE	Dm HUB	F	L	d	N. FLANGE	WEIGHT kg.
18 XXH 300	44700018	18	1F	181,91	178,87	198	140	91,4	110	28	163	25,15
20 XXH 300	44700020	20	1F	202,13	199,08	212	150	91,4	110	28	165	30,72
22 XXH 300	44700022	22	1F	222,34	219,29	240	150	91,4	110	28	169	36,86
24 XXH 300	44700024	24	1F	242,55	239,50	267	150	91,4	110	28	173	43,55
26 XXH 300	44700026	26	1F	262,76	259,79	290	150	91,4	110	28	178	50,80

MATERIAL **STEEL**
C 45CAD drawings available on our site
www.chiaravalli.comQuantity, availability and prices
on B2B Chiaravalli



FOR POSITIVE BELTS

TYPE **XXH 400**

PITCH 1" 1/4 (31.75 mm)

Different pitch of teeth available on request.

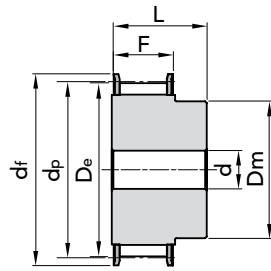

EXEC. 1F

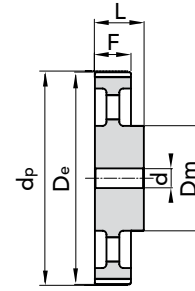

EXEC. 4

TYPE	P. NUMBER	N. TEETH	EXEC.	Dp	De	Df FLANGE	Dm HUB	F	L	d	N. FLANGE	WEIGHT kg.
18 XXH 400	44800018	18	1F	181,91	178,87	198	140	118,2	140	32	163	31,83
20 XXH 400	44800020	20	1F	202,13	199,08	212	150	118,2	140	32	165	38,88
22 XXH 400	44800022	22	1F	222,34	219,29	240	150	118,2	140	32	169	46,60
24 XXH 400	44800024	24	1F	242,55	239,50	267	150	118,2	140	32	173	55,10
26 XXH 400	44800026	26	1F	262,76	259,79	290	150	118,2	140	32	178	64,25

FOR POSITIVE BELTS

TYPE **XXH 500**

PITCH 1" 1/4 (31.75 mm)

Different pitch of teeth available on request.

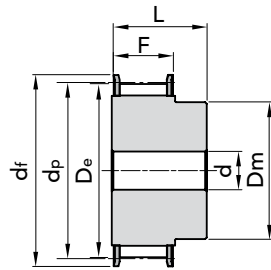

EXEC. 1F

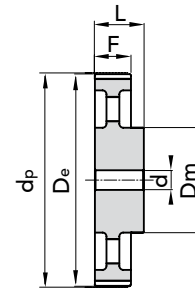

EXEC. 4

TYPE	P. NUMBER	N. TEETH	EXEC.	Dp	De	Df FLANGE	Dm HUB	F	L	d	N. FLANGE	WEIGHT kg.
18 XXH 500	44900018	18	1F	181,91	178,87	198	140	145,3	168	32	163	38,00
20 XXH 500	44900020	20	1F	202,13	199,08	212	150	145,3	168	32	165	44,05
22 XXH 500	44900022	22	1F	222,34	219,29	240	150	145,3	168	32	169	55,80
24 XXH 500	44900024	24	1F	242,55	239,50	267	150	145,3	168	32	173	62,90
26 XXH 500	44900026	26	1F	262,76	259,79	290	150	145,3	168	32	178	73,60

MATERIAL **STEEL**
C 45

CAD drawings available on our site
www.chiaravalli.com

Quantity, availability and prices on B2B Chiaravalli



The images do not identify the products.

TIMING PULLEYS with PILOT BORE TYPE XXH 400 - XXH 500



HOW TO INTERPRET THE CODE REFERENCE:

TL 30 - L 100

- TL Taper Lock®
- 30 N° OF TEETH
- L BELT PITCH
- 100 BELT WIDTH IN INCHES

TAPER LOCK® TIMING PULLEYS EXECUTIONS

TAPER LOCK® TIMING PULLEYS EXECUTIONS

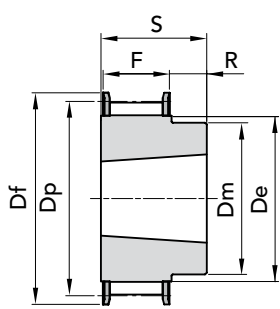

ESEC. 1F

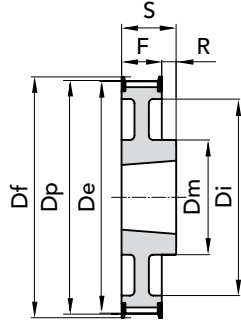

ESEC. 2F

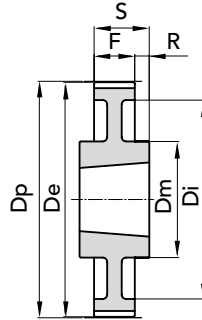

ESEC. 3

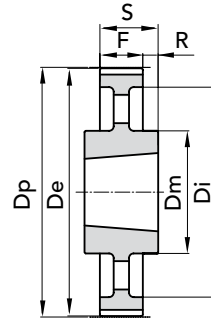

ESEC. 4

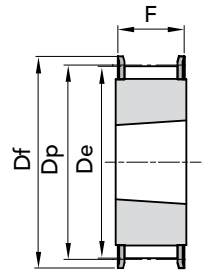

ESEC. 5F

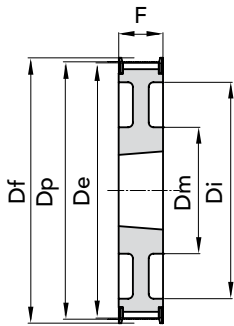

ESEC. 6F

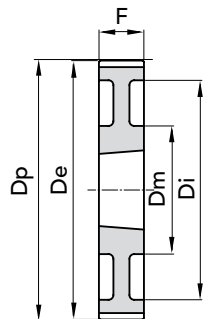

ESEC. 7

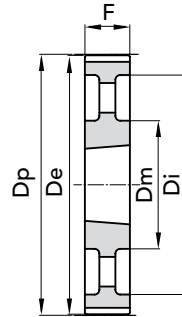

ESEC. 8

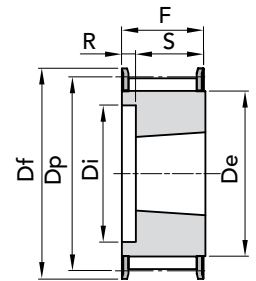

ESEC. 9F

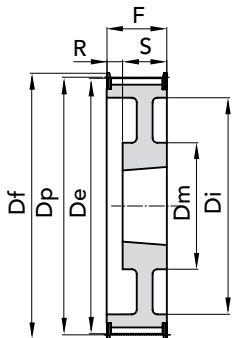

ESEC. 10F

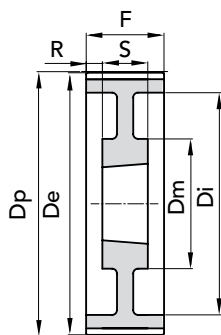

ESEC. 11

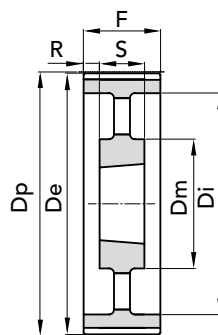

ESEC. 12

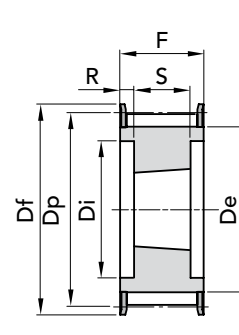

ESEC. 13F

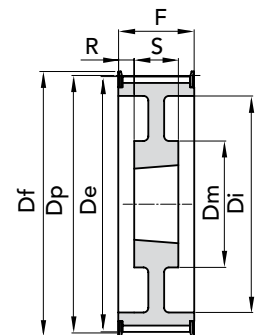

ESEC. 14F



TAPER LOCK® TIMING PULLEYS "PHOSPHATED"

FOR POSITIVE BELTS

TYPE L 050

PITCH 3/8" (9.52 mm)

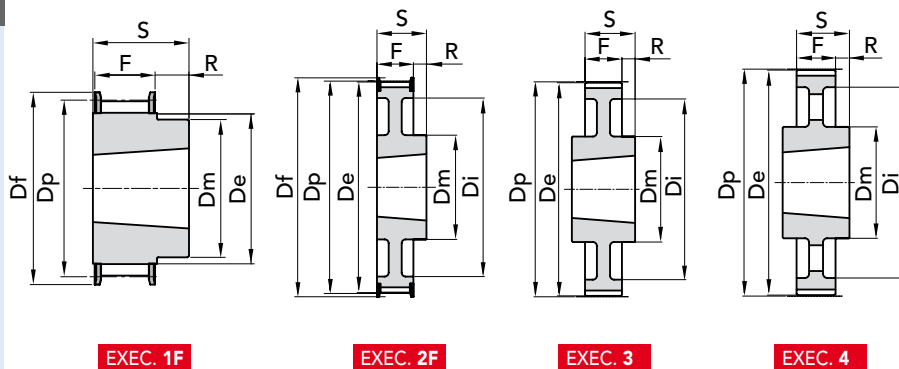

EXEC. 1F

EXEC. 2F

EXEC. 3

EXEC. 4

TYPE	P. NUMBER	EXEC.	BUSH.	Bore MAX	Dp	De	Df FLANGE	Dm HUB	Di	F	S	R	N. FLANGE	WEIGHT kg.
TL 18 L 050	42050418	1F	1108	28	54,57	53,81	60	45,00	-	19,0	22,0	3,0	58	0,20
TL 19 L 050	42050419	1F	1108	28	57,61	56,84	64	45	-	19,0	22,0	3,0	59	0,23
TL 20 L 050	42050420	1F	1108	28	60,64	59,88	66,5	48	-	19,0	22,0	3,0	60	0,27
TL 21 L 050	42050421	1F	1108	28	63,67	62,91	70	48	-	19,0	22,0	3,0	61	0,30
TL 22 L 050	42050422	1F	1108	28	66,70	65,94	75	51	-	19,0	22,0	3,0	62	0,34
TL 23 L 050	42050423	1F	1108	28	69,73	68,97	79	54	-	19,0	22,0	3,0	63	0,40
TL 24 L 050	42050424	1F	1108	28	72,77	72,00	79	54	-	19,0	22,0	3,0	63	0,45
TL 25 L 050	42050425	1F	1108	28	75,80	75,04	82,5	56	-	19,0	22,0	3,0	64	0,50
TL 26 L 050	42050426	1F	1108	28	78,83	78,07	86	60	-	19,0	22,0	3,0	65	0,55
TL 27 L 050	42050427	1F	1108	28	81,86	81,10	86	62	-	19,0	22,0	3,0	65	0,60
TL 28 L 050	42050428	1F	1108	28	84,89	84,13	91	65	-	19,0	22,0	3,0	66	0,65
TL 30 L 050	42050430	1F	1108	28	90,96	90,20	97	70	-	19,0	22,0	3,0	68	0,80
TL 32 L 050	42050432	1F	1108	28	97,02	96,26	102	74	-	19,0	22,0	3,0	70	0,98
TL 36 L 050	42050436	1F	1108	28	109,15	108,39	115	85	-	19,0	22,0	3,0	74	1,20
TL 40 L 050	42050440	1F	1610	42	121,28	120,51	128	97	-	19,0	25,0	6,0	78	1,40
TL 44 L 050	42050444	2F	1610	42	133,40	132,64	142	88	110	19,0	25,0	6,0	81	2,10
TL 48 L 050	42050448	2F	1610	42	145,53	147,77	150	88	120	19,0	25,0	6,0	85	2,30
TL 60 L 050	42050460	3	1610	42	181,91	181,15	-	92	166	19,0	25,0	3,0	-	2,20
TL 72 L 050	42050472	4	1610	42	218,30	217,53	-	92	202	19,0	25,0	3,0	-	2,10
TL 84 L 050	42050484	4	1610	42	254,68	253,90	-	92	236	19,0	25,0	3,0	-	2,46
TL 96 L 050	42050496	4	2012	50	291,06	290,30	-	106	270	19,0	32,0	6,5	-	3,36
TL 120 L 050	42050520	4	2012	50	363,83	363,07	-	106	343	19,0	32,0	6,5	-	4,44

TAPER LOCK® TIMING PULLEYS FOR POSITIVE BELTS "PHOSPHATED" L 050

MATERIAL:

STEEL C 45 UNI 7845

MATERIAL:

CAST-IRON G 20 UNI 5007

CAD drawings available on our site
www.chiaravalli.com

Quantity, availability and prices
on B2B Chiaravalli



FOR POSITIVE BELTS
TYPE L 075

PITCH 3/8" (9.52 mm)

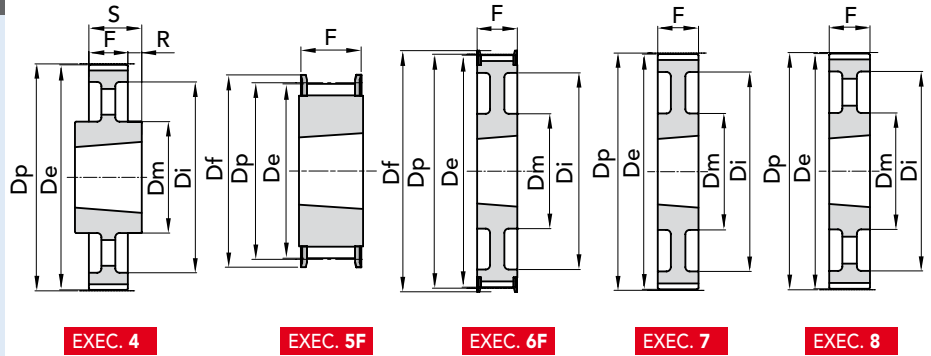

TYPE	P. NUMBER	EXEC.	BUSH.	Bore MAX	Dp	De	Df FLANGE	Dm HUB	Di	F	S	R	N. FLANGE	WEIGHT kg.
TL 18 L 075	42075418	5F	1108	28	54,57	53,81	60	-	-	25,0	25,0	-	58	0,25
TL 19 L 075	42075419	5F	1108	28	57,61	56,84	64	-	-	25,0	25,0	-	59	0,32
TL 20 L 075	42075420	5F	1108	28	60,64	59,88	66,5	-	-	25,0	25,0	-	60	0,35
TL 21 L 075	42075421	5F	1108	28	63,67	62,91	70	-	-	25,0	25,0	-	61	0,40
TL 22 L 075	42075422	5F	1108	28	66,70	65,94	75	-	-	25,0	25,0	-	62	0,44
TL 23 L 075	42075423	5F	1108	28	69,73	68,97	79	-	-	25,0	25,0	-	63	0,48
TL 24 L 075	42075424	5F	1108	28	72,77	72,00	79	-	-	25,0	25,0	-	63	0,55
TL 25 L 075	42075425	5F	1108	28	75,80	75,04	82,5	-	-	25,0	25,0	-	64	0,63
TL 26 L 075	42075426	5F	1108	28	78,83	78,07	86	-	-	25,0	25,0	-	65	0,66
TL 27 L 075	42075427	5F	1108	28	81,86	81,10	86	-	-	25,0	25,0	-	65	0,70
TL 28 L 075	42075428	5F	1108	28	84,89	84,13	91	-	-	25,0	25,0	-	66	0,72
TL 30 L 075	42075430	5F	1108	28	90,96	90,20	97	-	-	25,0	25,0	-	68	0,93
TL 32 L 075	42075432	5F	1108	28	97,02	96,26	102	-	-	25,0	25,0	-	70	1,10
TL 36 L 075	42075436	5F	1610	42	109,15	108,39	115	-	-	25,0	25,0	-	74	1,20
TL 40 L 075	42075440	5F	1610	42	121,28	120,51	128	-	-	25,0	25,0	-	78	1,70
TL 44 L 075	42075444	6F	1610	42	133,40	132,64	142	90	110	25,0	25,0	-	81	2,50
TL 48 L 075	42075448	6F	1610	42	145,53	147,77	150	92	120	25,0	25,0	-	85	2,60
TL 60 L 075	42075460	7	1610	42	181,91	181,15	-	92	166	25,0	25,0	-	-	3,00
TL 72 L 075	42075472	8	1610	42	218,30	217,53	-	92	202	25,0	25,0	-	-	2,33
TL 84 L 075	42075484	4	2012	50	254,68	253,90	-	106	236	25,0	32,0	3,5	-	3,55
TL 96 L 075	42075496	4	2012	50	291,06	290,30	-	106	270	25,0	32,0	3,5	-	3,95
TL 120 L 075	42075520	4	2012	50	363,83	363,07	-	106	343	25,0	32,0	3,5	-	5,61

MATERIAL:

STEEL C 45 UNI 7845

MATERIAL:

CAST-IRON G 20 UNI 5007

 CAD drawings available on our site
www.chiaravalli.com

 Quantity, availability and prices
 on B2B Chiaravalli





FOR POSITIVE BELTS

TYPE L 100

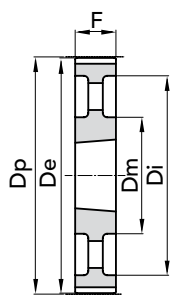
PITCH 3/8" (9.52 mm)

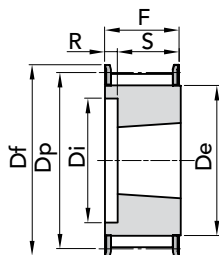

EXEC. 8



EXEC. 9F

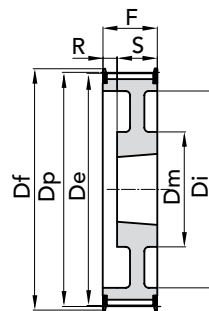

EXEC. 10F

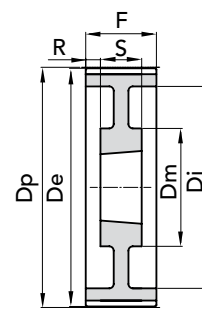

EXEC. 11

TYPE	P. NUMBER	EXEC.	BUSH.	Bore MAX	Dp	De	Df FLANGE	Dm HUB	Di	F	S	R	N. FLANGE	WEIGHT kg.
TL 18 L 100	42100418	9F	1108	28	54,57	53,81	60	-	38	31,0	22,0	9,0	58	0,20
TL 19 L 100	42100419	9F	1108	28	57,61	56,84	64	-	38	31,0	22,0	9,0	59	0,32
TL 20 L 100	42100420	9F	1108	28	60,64	59,88	66,5	-	45	31,0	22,0	9,0	60	0,41
TL 21 L 100	42100421	9F	1108	28	63,67	62,91	70	-	45	31,0	22,0	9,0	61	0,45
TL 22 L 100	42100422	9F	1108	28	66,70	65,94	75	-	48	31,0	22,0	9,0	62	0,47
TL 23 L 100	42100423	9F	1108	28	69,73	68,97	79	-	52	32,0	22,0	10,0	63	0,50
TL 24 L 100	42100424	9F	1108	28	72,77	72,00	79	-	52	32,0	22,0	10,0	63	0,64
TL 25 L 100	42100425	9F	1108	28	75,80	75,04	82,5	-	54	32,0	22,0	10,0	64	0,68
TL 26 L 100	42100426	9F	1108	28	78,83	78,07	86	-	60	32,0	22,0	10,0	65	0,70
TL 27 L 100	42100427	9F	1108	28	81,86	81,10	86	-	60	32,0	22,0	10,0	65	0,83
TL 28 L 100	42100428	9F	1108	28	84,89	84,13	91	-	65	32,0	22,0	10,0	66	0,85
TL 30 L 100	42100430	9F	1210	32	90,96	90,20	97	-	71	32,0	25,0	7,0	68	0,90
TL 32 L 100	42100432	9F	1210	32	97,02	96,26	102	-	75	32,0	25,0	7,0	70	1,05
TL 36 L 100	42100436	9F	1610	42	109,15	108,39	115	-	86	32,0	25,0	7,0	74	1,40
TL 40 L 100	42100440	9F	1610	42	121,28	120,51	128	-	96	32,0	25,0	7,0	78	1,65
TL 44 L 100	42100444	10F	1610	42	133,40	132,64	142	90	110	32,0	25,0	7,0	81	2,70
TL 48 L 100	42100448	10F	1610	42	145,53	144,77	150	92	120	32,0	25,0	7,0	85	2,80
TL 60 L 100	42100460	11	1610	42	181,91	181,15	-	92	166	32,0	25,0	3,5	-	2,70
TL 72 L 100	42100472	8	2012	50	218,30	217,53	-	106	202	32,0	32,0	-	-	2,96
TL 84 L 100	42100484	8	2012	50	254,68	253,90	-	106	236	32,0	32,0	-	-	3,87
TL 96 L 100	42100496	8	2012	50	291,06	290,30	-	106	270	32,0	32,0	-	-	4,64
TL 120 L 100	42100520	8	2012	50	363,83	363,07	-	106	343	32,0	32,0	-	-	6,37

TAPER LOCK® TIMING PULLEYS FOR POSITIVE BELTS "PHOSPHATED" L 100

MATERIAL:

STEEL C 45 UNI 7845

MATERIAL:

CAST-IRON G 20 UNI 5007

CAD drawings available on our site
www.chiaravalli.com

Quantity, availability and prices
 on B2B Chiaravalli



The images do not identify the products.

FOR POSITIVE BELTS
TYPE H 100

PITCH 1/2" (12.7 mm)

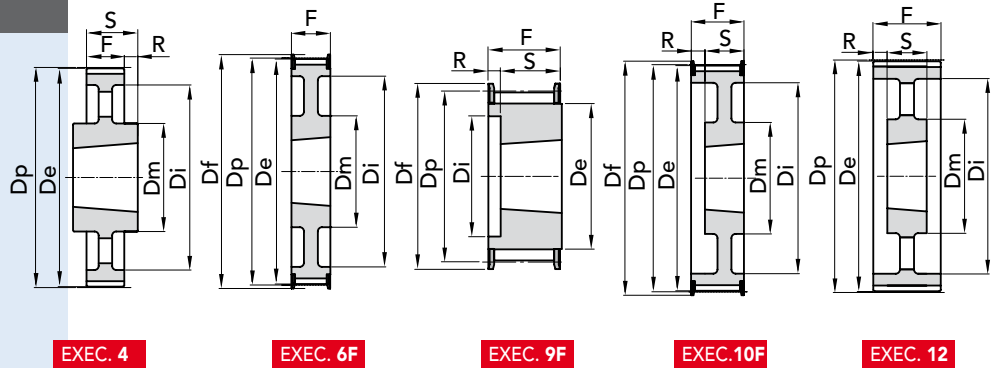

EXEC. 4

EXEC. 6F

EXEC. 9F

EXEC. 10F

EXEC. 12

TYPE	P. NUMBER	EXEC.	BUSH.	Bore MAX	Dp	De	Df FLANGE	Dm HUB	Di	F	S	R	N. FLANGE	WEIGHT kg.
TL 16 H 100	43100416	9F	1108	28	64,68	63,31	70	-	45	31,0	22,0	9,0	61	0,42
TL 18 H 100	43100418	9F	1210	32	72,77	71,39	79	-	52	31,0	25,0	6,0	63	0,49
TL 19 H 100	43100419	9F	1210	32	76,81	74,44	82,5	-	56	31,0	25,0	6,0	64	0,62
TL 20 H 100	43100420	9F	1210	32	80,55	79,48	87	-	60	31,0	25,0	6,0	76	0,73
TL 21 H 100	43100421	9F	1210	32	84,89	83,52	91	-	64	32,0	25,0	7,0	66	0,80
TL 22 H 100	43100422	9F	1210	32	88,94	87,56	94	-	67	32,0	25,0	7,0	67	0,94
TL 23 H 100	43100423	9F	1610	42	92,98	91,61	97	-	70	32,0	25,0	7,0	68	0,97
TL 24 H 100	43100424	9F	1610	42	97,02	95,65	102	-	73,5	32,0	25,0	7,0	70	1,05
TL 25 H 100	43100425	9F	1610	42	101,06	99,69	106	-	77	32,0	25,0	7,0	71	1,10
TL 26 H 100	43100426	9F	1610	42	105,11	103,73	112	-	82	32,0	25,0	7,0	72	1,20
TL 27 H 100	43100427	9F	1610	42	109,15	107,78	115	-	85	32,0	25,0	7,0	74	1,35
TL 28 H 100	43100428	9F	1610	42	113,19	111,82	120	-	90,5	32,0	25,0	7,0	75	1,50
TL 30 H 100	43100430	9F	1610	42	121,28	119,90	128	-	98	32,0	25,0	7,0	78	1,78
TL 32 H 100	43100432	10F	1610	42	129,36	127,99	135	80	106	32,0	25,0	7,0	80	2,05
TL 36 H 100	43100436	10F	1610	42	145,53	144,16	150	92	121	32,0	25,0	7,0	85	2,80
TL 40 H 100	43100440	10F	1610	42	161,70	160,33	168	92	138	32,0	25,0	7,0	90	3,65
TL 44 H 100	43100444	6F	2012	50	177,87	176,50	184	106	152	32,0	32,0	-	95	3,86
TL 48 H 100	43100448	6F	2012	50	194,04	192,67	200	106	169	32,0	32,0	-	100	4,20
TL 60 H 100	43100460	12	2012	50	242,55	241,18	-	106	223	34,0	32,0	1,0	-	3,76
TL 72 H 100	43100472	12	2012	50	291,06	289,69	-	106	270	34,0	32,0	1,0	-	4,88
TL 84 H 100	43100484	12	2012	50	339,57	338,20	-	106	318	34,0	32,0	1,0	-	6,12
TL 96 H 100	43100496	4	2517	60	388,08	386,71	-	119	366	34,0	45,0	5,5	-	7,95
TL 120 H 100	43100520	4	2517	60	485,10	483,73	-	119	462	34,0	45,0	5,5	-	10,05

MATERIAL:

STEEL C 45 UNI 7845

MATERIAL:

CAST-IRON G 20 UNI 5007

 CAD drawings available on our site
www.chiaravalli.com

 Quantity, availability and prices
 on B2B Chiaravalli





FOR POSITIVE BELTS

TYPE H 150

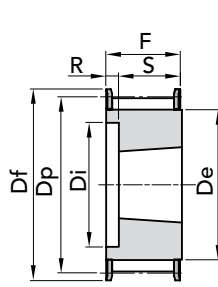
PITCH 1/2" (12.7 mm)

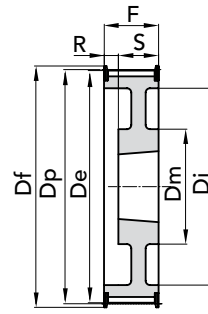

EXEC. 9F



EXEC. 10F

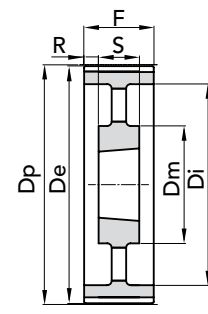

EXEC. 12

TYPE	P. NUMBER	EXEC.	BUSH.	Bore MAX	Dp	De	Df FLANGE	Dm HUB	Di	F	S	R	N. FLANGE	WEIGHT kg.
TL 18 H 150	43150418	9F	1210	32	72,77	71,39	79	-	52	45,0	25,0	20,0	63	0,60
TL 19 H 150	43150419	9F	1210	32	76,81	74,44	82,5	-	56	45,0	25,0	20,0	64	0,72
TL 20 H 150	43150420	9F	1210	32	80,55	79,48	87	-	60	45,0	25,0	20,0	76	0,83
TL 21 H 150	43150421	9F	1210	32	84,89	83,52	91	-	64	45,0	25,0	20,0	66	1,00
TL 22 H 150	43150422	9F	1210	32	88,94	87,56	94	-	67	45,0	25,0	20,0	67	1,25
TL 23 H 150	43150423	9F	1610	42	92,98	91,61	97	-	70	45,0	25,0	20,0	68	1,05
TL 24 H 150	43150424	9F	1610	42	97,02	95,65	102	-	73,5	45,0	25,0	20,0	70	1,10
TL 25 H 150	43150425	9F	1610	42	101,06	99,69	106	-	77	45,0	25,0	20,0	71	1,30
TL 26 H 150	43150426	9F	1610	42	105,11	103,73	112	-	82	45,0	25,0	20,0	72	1,42
TL 27 H 150	43150427	9F	1610	42	109,15	107,78	115	-	85	45,0	25,0	20,0	74	1,65
TL 28 H 150	43150428	9F	1610	42	113,19	111,82	120	-	90,5	45,0	25,0	20,0	75	1,88
TL 30 H 150	43150430	9F	1610	42	121,28	119,90	128	-	98	45,0	25,0	20,0	78	2,05
TL 32 H 150	43150432	10F	1610	42	129,36	127,99	135	80	106	45,0	25,0	20,0	80	2,35
TL 36 H 150	43150436	10F	1610	42	145,53	144,16	150	92	121	45,0	25,0	20,0	85	3,20
TL 40 H 150	43150440	10F	1610	42	161,70	160,33	168	92	138	45,0	25,0	20,0	90	4,10
TL 44 H 150	43150444	10F	2012	50	177,87	176,50	184	106	152	45,0	32,0	13,0	95	4,50
TL 48 H 150	43150448	10F	2012	50	194,04	192,67	200	106	169	45,0	32,0	13,0	100	4,80
TL 60 H 150	43150460	12	2012	50	242,55	241,18	-	106	223	46,0	32,0	7,0	-	4,51
TL 72 H 150	43150472	12	2012	50	291,06	289,69	-	106	270	46,0	32,0	7,0	-	6,16
TL 84 H 150	43150484	12	2012	50	339,57	338,20	-	106	318	46,0	32,0	7,0	-	7,40
TL 96 H 150	43150496	12	2517	60	388,08	386,71	-	119	366	46,0	45,0	0,5	-	9,87
TL 120 H 150	43150520	12	2517	60	485,10	483,73	-	119	462	46,0	45,0	0,5	-	13,5

TAPER LOCK® TIMING PULLEYS FOR POSITIVE BELTS "PHOSPHATED" H 150

MATERIAL:

STEEL C 45 UNI 7845

MATERIAL:

CAST-IRON G 20 UNI 5007

CAD drawings available on our site
www.chiaravalli.com

Quantity, availability and prices
 on B2B Chiaravalli



The images do not identify the products.

FOR POSITIVE BELTS
TYPE H 200

PITCH 1/2" (12.7 mm)

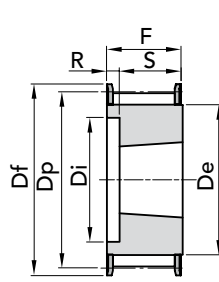
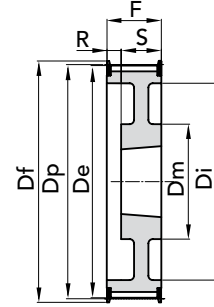
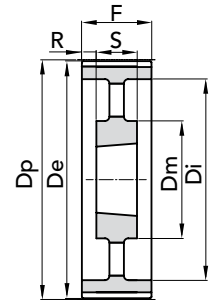
EXEC. 9F

EXEC. 10F

EXEC. 12

TYPE	P. NUMBER	EXEC.	BUSH.	Bore MAX	Dp	De	Df FLANGE	Dm HUB	Di	F	S	R	N. FLANGE	WEIGHT kg.
TL 18 H 200	43200418	9F	1210	32	72,77	71,39	79	-	52	58,0	25,0	33,0	63	0,84
TL 19 H 200	43200419	9F	1210	32	76,81	74,44	82,5	-	56	58,0	25,0	33,0	64	0,96
TL 20 H 200	43200420	9F	1610	42	80,55	79,48	87	-	62	58,0	25,0	33,0	76	0,93
TL 21 H 200	43200421	9F	1610	42	84,89	83,52	91	-	64	58,0	25,0	33,0	66	1,07
TL 22 H 200	43200422	9F	1610	42	88,94	87,56	94	-	67	58,0	25,0	33,0	67	1,25
TL 23 H 200	43200423	9F	1610	42	92,98	91,61	97	-	70	58,0	25,0	33,0	68	1,40
TL 24 H 200	43200424	9F	1610	42	97,02	95,65	102	-	73,5	58,0	25,0	33,0	70	1,55
TL 25 H 200	43200425	9F	1610	42	101,06	99,69	106	-	77	58,0	25,0	33,0	71	1,71
TL 26 H 200	43200426	9F	1610	42	105,11	103,73	112	-	82	58,0	25,0	33,0	72	1,84
TL 27 H 200	43200427	9F	1610	42	109,15	107,78	115	-	85	58,0	25,0	33,0	74	2,06
TL 28 H 200	43200428	9F	1610	42	113,19	111,82	120	-	90,5	58,0	25,0	33,0	75	2,17
TL 30 H 200	43200430	9F	1610	42	121,28	119,90	128	-	98	58,0	25,0	33,0	78	2,60
TL 32 H 200	43200432	9F	2012	50	129,36	127,99	135	-	106	58,0	32,0	26,0	80	2,95
TL 36 H 200	43200436	10F	2012	50	145,53	144,16	150	102	121	58,0	32,0	26,0	85	3,62
TL 40 H 200	43200440	10F	2012	50	161,70	160,33	168	106	138	58,0	32,0	26,0	90	4,33
TL 44 H 200	43200444	10F	2012	50	177,87	176,50	184	106	152	58,0	32,0	26,0	95	5,33
TL 48 H 200	43200448	10F	2517	60	194,04	192,67	200	119	168	58,0	45,0	13,0	100	6,47
TL 60 H 200	43200460	12	2517	60	242,55	241,18	-	119	223	60,0	45,0	7,5	-	5,86
TL 72 H 200	43200472	12	2517	60	291,06	289,69	-	119	270	60,0	45,0	7,5	-	7,42
TL 84 H 200	43200484	12	2517	60	339,57	338,20	-	119	320	60,0	45,0	7,5	-	8,73
TL 96 H 200	43200496	12	2517	60	388,08	386,71	-	119	366	60,0	45,0	7,5	-	10,83
TL 120 H 200	43200520	12	2517	60	485,10	483,73	-	119	462	60,0	45,0	7,5	-	14,95

 MATERIAL **STEEL**
C 45 UNI 7845

 MATERIAL **CAST-IRON**
G 20 UNI 5007

 CAD drawings available on our site
www.chiaravalli.com

 Quantity, availability and prices
 on B2B Chiaravalli





TAPER LOCK® TIMING PULLEYS "PHOSPHATED"

FOR POSITIVE BELTS

TYPE H 300

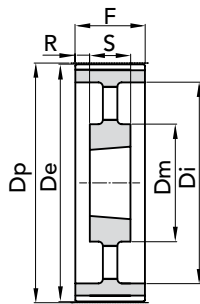
PITCH 1/2" (12.7 mm)



EXEC. 12

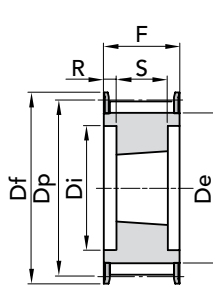

EXEC. 13F

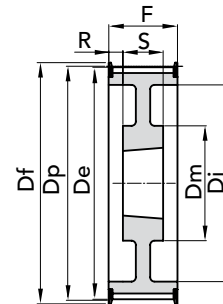

EXEC. 14F

TYPE	P. NUMBER	EXEC.	BUSH.	Bore MAX	Dp	De	Df FLANGE	Dm HUB	Di	F	S	R	N. FLANGE	WEIGHT kg.
TL 20 H 300	43300420	13F	1615	42	80,85	79,48	87	-	64,5	84,0	38,0	23,0	76	1,22
TL 21 H 300	43300421	13F	1615	42	84,89	83,52	91	-	65	84,0	38,0	23,0	66	1,52
TL 22 H 300	43300422	13F	1615	42	88,94	87,56	94	-	67	84,0	38,0	23,0	67	1,80
TL 23 H 300	43300423	13F	1615	42	92,98	91,61	97	-	70	84,0	38,0	23,0	68	2,04
TL 24 H 300	43300424	13F	1615	42	97,02	95,65	102	-	73,5	84,0	38,0	23,0	70	2,29
TL 25 H 300	43300425	13F	1615	42	101,06	99,69	106	-	77	84,0	38,0	23,0	71	2,54
TL 26 H 300	43300426	13F	1615	42	105,11	103,73	112	-	82	84,0	38,0	23,0	72	2,73
TL 27 H 300	43300427	13F	2012	50	109,15	107,78	115	-	85	84,0	32,0	26,0	74	2,54
TL 28 H 300	43300428	13F	2012	50	113,19	111,82	120	-	90,5	84,0	32,0	26,0	75	2,68
TL 30 H 300	43300430	13F	2012	60	121,28	119,90	128	-	98	84,0	32,0	26,0	78	3,21
TL 32 H 300	43300432	13F	2517	60	129,36	127,99	135	-	106	84,0	45,0	19,5	80	3,58
TL 36 H 300	43300436	13F	2517	60	145,53	144,16	150	-	121	84,0	45,0	19,5	85	4,99
TL 40 H 300	43300440	13F	2517	60	161,70	160,33	168	-	138	84,0	45,0	19,5	90	6,50
TL 44 H 300	43300444	14F	2517	60	177,87	176,50	184	119	150	86,0	45,0	20,5	95	7,55
TL 48 H 300	43300448	14F	2517	60	194,04	192,67	200	119	165	86,0	45,0	20,5	100	8,66
TL 60 H 300	43300460	12	2517	60	242,55	241,18	-	119	223	86,0	45,0	20,5	-	7,42
TL 72 H 300	43300472	12	2517	60	291,06	289,69	-	119	270	86,0	45,0	20,5	-	9,33
TL 84 H 300	43300484	12	2517	60	339,57	338,20	-	119	320	86,0	45,0	20,5	-	11,19
TL 96 H 300	43300496	12	3030	75	388,08	386,71	-	150	362	86,0	76,0	5,0	-	17,96
TL 120 H 300	43300520	12	3030	75	485,10	483,73	-	150	460	86,0	76,0	5,0	-	22,23

TAPER LOCK® TIMING PULLEYS FOR POSITIVE BELTS "PHOSPHATED" H 300

MATERIAL:

STEEL C 45 UNI 7845

MATERIAL:

CAST-IRON G 20 UNI 5007

CAD drawings available on our site
www.chiaravalli.com

Quantity, availability and prices
 on B2B Chiaravalli



The images do not identify the products.



HTD® TIMING PULLEYS with PILOT BORE

CHIARAVALLI GROUP S.p.A. manufactures the **HTD®** pulleys in the following pitches: 3mm., 5mm., 8mm. and 14mm. and in the following versions:

- a) **HTD®** Pilot Bore pulleys
- b) **HTD®** with **Taper-Lock®** taper bush

BELT IDENTIFICATION:

34 - 8M - 50 ———— | 34 N° teeth
 | 8M pitch in mm
 | 50 belt width

TL 30 - 14M - 55 ———— | TL Taper Lock
 | 30 N° teeth
 | 14M pitch in mm
 | 50 belt width

PULLEY BALANCING VALUES

The **HTD®** pulleys manufactured by our company are not balanced. Balancing is performed at cost, only on request. We are able to balance pulleys up to a maximum diameter of 560 mm. and issue the relative certificate.

CHARACTERISTICS OF THE ...GOLE

DIAMETERS PULLEY	WIDTH SURFACE	MAXIMUM UNBALANCE IN GRAMS
from 199 - 301	60	6
from 302 - 599	60	10
from 199 - 301	from 60 - 90	10
from 302 - 599		15
from 600 - 999		20
greater than 1000		30
from 199 - 301	from 100 - 199	20
from 302 - 599		30
from 600 - 999		40
greater than 1000		60

CONSTRUCTION TOLERANCE VALUES

De pulley

Tolerance in mm

from Ø	0 to Ø 30	- 0	+ 0.05
from Ø	31 to Ø 50	- 0	+ 0.08
from Ø	51 to Ø 100	- 0	+ 0.10
from Ø	101 to Ø 179	- 0	+ 0.13
from Ø	180 to a Ø 300	- 0	+ 0.15
from Ø	301 to Ø 500	- 0	+ 0.18
from Ø	greater than Ø 510	- 0	+ 0.20

ECCENTRICITY

The bore and outer diameter must be concentric in compliance with the tolerance values indicated below

external Ø	Total eccentricity (mm)
mm	Total measurement of the comparison
up to 199	0.10
greater than 200	0.0005 for mm Ø
	This value cannot exceed the tolerance for the external Ø.

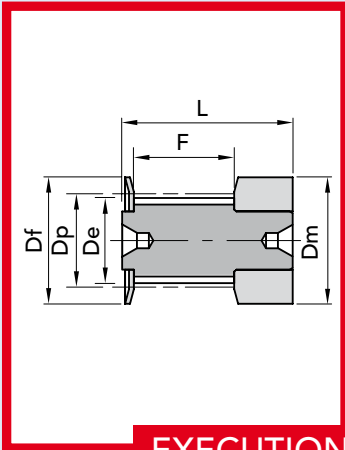

EXECUTION 0F

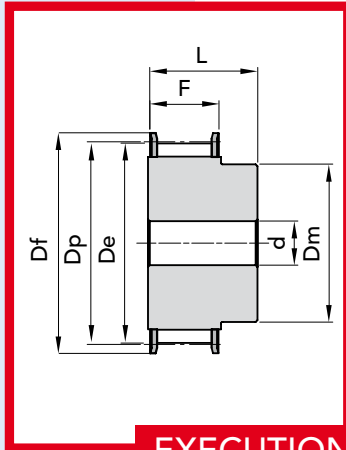

EXECUTION 1F

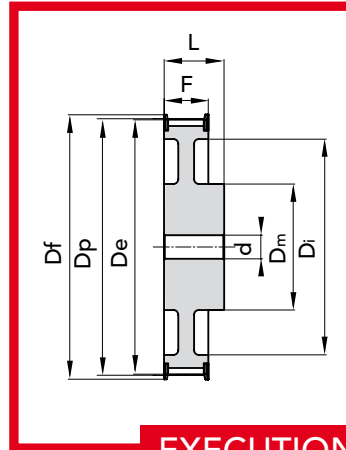

EXECUTION 2F

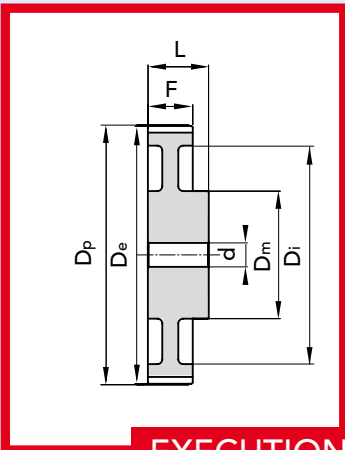

EXECUTION 3

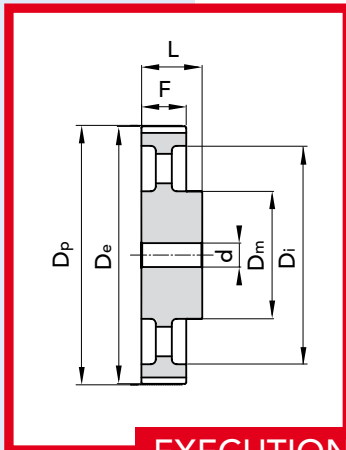

EXECUTION 4

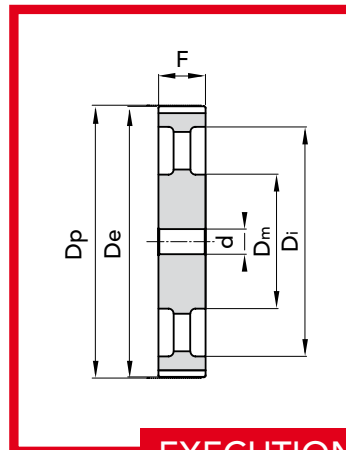

EXECUTION 5

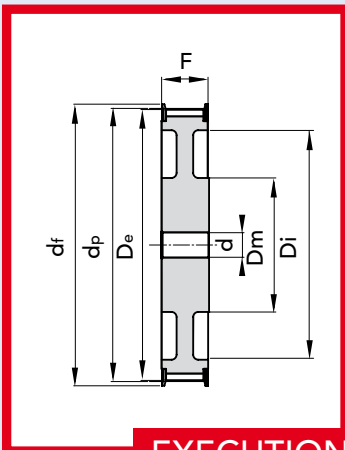

EXECUTION 6F

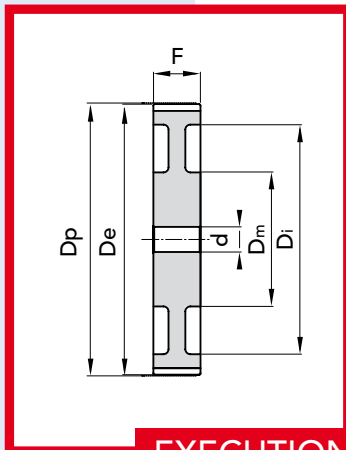

EXECUTION 7

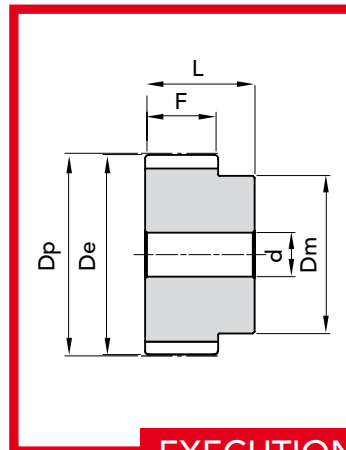

EXECUTION 8

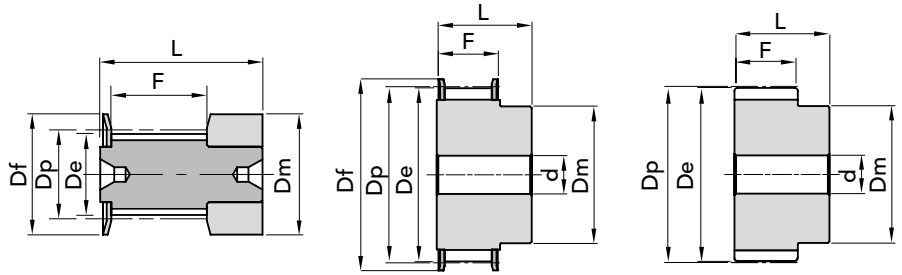
TYPE **3M 09**

EXEC. 0F

EXEC. 1F

EXEC. 8

TYPE	P. NUMBER	N. TEETH	EXEC.	Dp	De	Df FLANGE	Dm HUB	F	L	d Ø Bore	N. FLANGE	WEIGHT kg.
10- 3M- 09F	40109010	10	0F	9,55	8,79	13	13	10,2	17,5	-	501	0,01
12- 3M- 09F	40109012	12	0F	11,46	10,70	15	15	10,2	17,5	-	502	0,01
14- 3M- 09F	40109014	14	0F	13,37	12,61	16	16	10,2	17,5	-	503	0,01
15- 3M- 09F	40109015	15	0F	14,32	13,56	17,5	17,5	10,2	17,5	-	516	0,01
16- 3M- 09F	40109016	16	1F	15,28	14,52	17,5	10	12,8	20,6	4	504	0,01
18- 3M- 09F	40109018	18	1F	17,19	16,43	20	11	12,8	20,6	6	505	0,01
20- 3M- 09F	40109020	20	1F	19,10	18,34	23	13	12,8	20,6	6	517	0,01
21- 3M- 09F	40109021	21	1F	20,05	19,29	25	13	12,8	20,6	6	518	0,01
22- 3M- 09F	40109022	22	1F	21,01	20,25	25	13	12,8	20,6	6	518	0,01
24- 3M- 09F	40109024	24	1F	22,92	22,16	25	13	12,8	20,6	6	518	0,02
26- 3M- 09F	40109026	26	1F	24,83	24,07	28	16	12,8	20,6	6	508	0,02
28- 3M- 09F	40109028	28	1F	26,74	25,98	32	18	12,8	20,6	6	509	0,02
30- 3M- 09F	40109030	30	1F	28,65	27,89	32	20	12,8	20,6	6	509	0,30
32- 3M- 09F	40109032	32	1F	30,56	29,80	36	22	12,8	20,6	6	510	0,30
36- 3M- 09F	40109036	36	1F	34,38	33,62	39	26	13,4	22,2	6	519	0,05
40- 3M- 09F	40109040	40	1F	38,20	37,44	42	28	13,4	22,2	6	513	0,06
44- 3M- 09F	40109044	44	1F	42,02	41,26	48	33	13,4	22,2	6	520	0,07
48- 3M- 09	40109048	48	8	45,84	45,08	-	33	13,4	22,2	8	-	0,11
60- 3M- 09	40109060	60	8	57,30	56,54	-	33	13,4	22,2	8	-	0,11
72- 3M- 09	40109072	72	8	68,75	67,99	-	33	13,4	22,2	8	-	0,15

MATERIAL **ALUMINIUM**CAD drawings available on our site
www.chiaravalli.comQuantity, availability and prices
on B2B Chiaravalli



TYPE 3M 15

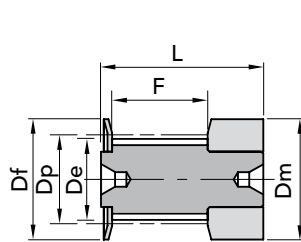

EXEC. 0F

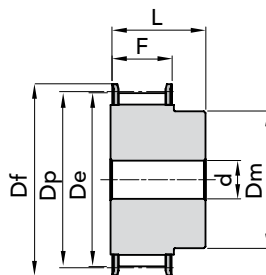

EXEC. 1F

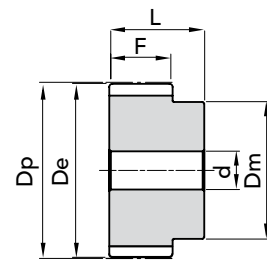

EXEC. 8

TYPE	P. NUMBER	N. TEETH	EXEC.	Dp	De	Df FLANGE	Dm HUB	F	L	d Ø Bore	N. FLANGE	WEIGHT kg.
10- 3M- 15F	40115010	10	0F	9,55	8,79	13	13	17	26	-	501	0,01
12- 3M- 15F	40115012	12	0F	11,46	10,70	15	15	17	26	-	502	0,01
14- 3M- 15F	40115014	14	0F	13,37	12,61	16	16	17	26	-	503	0,01
15- 3M- 15F	40115015	15	0F	14,32	13,56	17,5	17,5	17	26	-	516	0,01
16- 3M- 15F	40115016	16	1F	15,28	14,52	17,5	10	19,5	26	4	504	0,01
18- 3M- 15F	40115018	18	1F	17,19	16,43	20	11	19,5	26	6	505	0,01
20- 3M- 15F	40115020	20	1F	19,10	18,34	23	13	19,5	26	6	517	0,01
21- 3M- 15F	40115021	21	1F	20,05	19,29	25	13	19,5	26	6	518	0,02
22- 3M- 15F	40115022	22	1F	21,01	20,25	25	13	19,5	26	6	518	0,02
24- 3M- 15F	40115024	24	1F	22,92	22,16	25	13	19,5	26	6	518	0,02
26- 3M- 15F	40115026	26	1F	24,83	24,07	28	16	19,5	26	6	508	0,03
28- 3M- 15F	40115028	28	1F	26,74	25,98	32	18	19,5	26	6	509	0,03
30- 3M- 15F	40115030	30	1F	28,65	27,89	32	20	19,5	26	6	509	0,04
32- 3M- 15F	40115032	32	1F	30,56	29,80	36	22	19,5	26	6	510	0,04
36- 3M- 15F	40115036	36	1F	34,38	33,62	39	26	20	30	6	519	0,06
40- 3M- 15F	40115040	40	1F	38,20	37,44	42	28	20	30	6	513	0,08
44-3M- 15	40115044	44	1F	42,02	41,26	48	33	20	30	6	520	0,10
48- 3M- 15	40115048	48	8	45,84	45,08	-	33	20	30	8	-	0,10
60- 3M- 15	40115060	60	8	57,30	56,54	-	33	20	30	8	-	0,15
72- 3M- 15	40115072	72	8	68,75	67,99	-	33	20	30	8	-	0,21

MATERIAL ALUMINIUM

CAD drawings available on our site
www.chiaravalli.com

Quantity, availability and prices
on B2B Chiaravalli



The images do not identify the products.

PHOSPHATED

 TYPE **5M 09**

Aluminium pulleys are not phosphated.

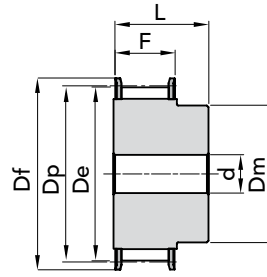
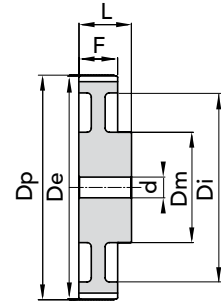
EXEC. 1F

EXEC. 3

TYPE	P. NUMBER	N. TEETH	EXEC.	Dp	De	Df FLANGE	Dm HUB	Di	F	L	d Ø Bore	N. FLANGE	WEIGHT kg.
12- 5M- 09F	40209012	12	1F	19,10	17,96	23	12	-	14,5	20	4	14	0,03
14- 5M- 09F	40209014	14	1F	22,28	21,14	25	13	-	14,5	20	6	2	0,04
15- 5M- 09F	40209015	15	1F	23,37	22,73	28	16	-	14,5	20	6	4	0,05
16- 5M- 09F	40209016	16	1F	25,46	24,32	28	16,5	-	14,5	20	6	4	0,06
18- 5M- 09F	40209018	18	1F	28,65	27,51	32	20	-	14,5	20	6	6	0,07
20- 5M- 09F	40209020	20	1F	31,83	30,69	36	23	-	14,5	22,5	6	8	0,10
21- 5M- 09F	40209021	21	1F	33,42	32,28	38	24	-	14,5	22,5	6	9	0,12
22- 5M- 09F	40209022	22	1F	35,01	33,87	39	25,5	-	14,5	22,5	6	15	0,13
24- 5M- 09F	40209024	24	1F	38,20	37,06	42	27	-	14,5	22,5	6	13	0,15
26- 5M- 09F	40209026	26	1F	41,38	40,24	44	30	-	14,5	22,5	6	12	0,18
28- 5M- 09F	40209028	28	1F	44,56	43,42	48	30,5	-	14,5	22,5	6	11	0,21
30- 5M- 09F	40209030	30	1F	47,75	46,60	51	35	-	14,5	22,5	6	16	0,25
32- 5M- 09F	40209032	32	1F	50,93	49,79	54	38	-	14,5	22,5	8	18	0,28
36- 5M- 09F	40209036	36	1F	57,30	56,16	60	38	-	14,5	22,5	8	21	0,33
40- 5M- 09F	40209040	40	1F	63,66	62,52	71	38	-	14,5	22,5	8	25	0,42
44- 5M- 09	40209044	44	3	70,03	68,89	-	38	54	14,5	25,5	8	-	0,17
48- 5M- 09	40209048	48	3	76,39	75,25	-	45	61	14,5	25,5	8	-	0,18
60- 5M- 09	40209060	60	3	95,49	94,35	-	45	80	14,5	25,5	8	-	0,23
72- 5M- 09	40209072	72	3	114,59	113,45	-	45	100	14,5	25,5	8	-	0,42

 MATERIAL **STEEL**

 MATERIAL **ALUMINIUM**

 CAD drawings available on our site
www.chiaravalli.com

 Quantity, availability and prices
 on B2B Chiaravalli





PHOSPHATED

TYPE 5M 15

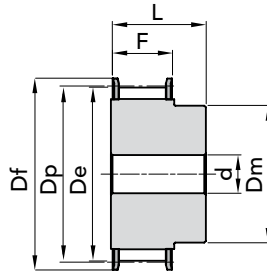
Aluminium pulleys are not phosphated.

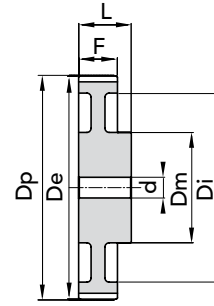

EXEC. 1F



EXEC. 3

TYPE	P. NUMBER	N. TEETH	EXEC.	Dp	De	Df FLANGE	Dm HUB	Di	F	L	d Ø Bore	N. FLANGE	WEIGHT kg.
12- 5M- 15F	40215012	12	1F	19,10	17,96	23	12	-	20,5	26	-	14	0,03
14- 5M- 15F	40215014	14	1F	22,28	21,14	25	13	-	20,5	26	6	2	0,04
15- 5M- 15F	40215015	15	1F	23,37	22,73	28	16	-	20,5	26	6	4	0,05
16- 5M- 15F	40215016	16	1F	25,46	24,32	28	16,5	-	20,5	26	6	4	0,06
18- 5M- 15F	40215018	18	1F	28,65	27,51	32	20	-	20,5	26	6	6	0,09
20- 5M- 15F	40215020	20	1F	31,83	30,69	36	23	-	20,5	26	6	8	0,12
21- 5M- 15F	40215021	21	1F	33,42	32,28	38	24	-	20,5	26	6	9	0,14
22- 5M- 15F	40215022	22	1F	35,01	33,87	39	25,5	-	20,5	26	6	15	0,15
24- 5M- 15F	40215024	24	1F	38,20	37,06	42	27	-	20,5	28	6	13	0,19
26- 5M- 15F	40215026	26	1F	41,38	40,24	44	30	-	20,5	28	6	12	0,23
28- 5M- 15F	40215028	28	1F	44,56	43,42	48	30,5	-	20,5	28	6	11	0,26
30- 5M- 15F	40215030	30	1F	47,75	46,60	51	35	-	20,5	28	6	16	0,32
32- 5M- 15F	40215032	32	1F	50,93	49,79	54	38	-	20,5	28	8	18	0,35
36- 5M- 15F	40215036	36	1F	57,30	56,16	60	38	-	20,5	28	8	21	0,43
40- 5M- 15F	40215040	40	1F	63,66	62,52	71	38	-	20,5	28	8	25	0,52
44- 5M- 15	40215044	44	3	70,03	68,89	-	38	54	20,5	30	8	-	0,23
48- 5M- 15	40215048	48	3	76,39	75,25	-	38	61	20,5	30	8	-	0,29
60- 5M- 15	40215060	60	3	95,49	94,35	-	50	80	20,5	30	8	-	0,30
72- 5M- 15	40215072	72	3	114,59	113,45	-	50	100	20,5	30	8	-	0,59

MATERIAL **STEEL**

MATERIAL **ALUMINIUM**

CAD drawings available on our site
www.chiaravalli.com

Quantity, availability and prices
on B2B Chiaravalli



The images do not identify the products.

HTD® TIMING PULLEYS with PILOT BORE "PHOSPHATED" 5M 15



PHOSPHATED

TYPE **5M 25**

Aluminium pulleys are not phosphated.

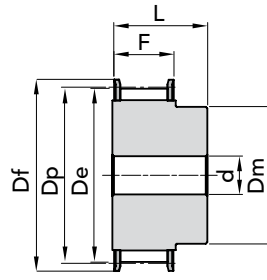

EXEC. 1F

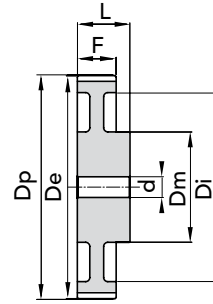

EXEC. 3

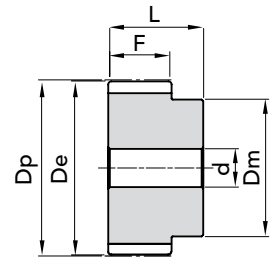

EXEC. 8

HTD® TIMING PULLEYS with PILOT BORE "PHOSPHATED" 5M 25

TYPE	P. NUMBER	N. TEETH	EXEC.	Dp	De	Df FLANGE	Dm HUB	Di	F	L	d Ø Bore	N. FLANGE	WEIGHT kg.
12- 5M- 25F	40225012	12	1F	19,10	17,96	23	12	-	30,5	36	-	14	0,05
14- 5M- 25F	40225014	14	1F	22,28	21,14	25	13	-	30,5	36	6	2	0,08
15- 5M- 25F	40225015	15	1F	23,87	22,73	28	16	-	30,5	36	6	4	0,09
16- 5M- 25F	40225016	16	1F	25,46	24,32	28	16,5	-	30,5	36	6	4	0,11
18- 5M- 25F	40225018	18	1F	28,65	27,51	32	20	-	30,5	36	6	6	0,13
20- 5M- 25F	40225020	20	1F	31,83	30,69	36	23	-	30,5	36	6	8	0,17
21- 5M- 25F	40225021	21	1F	33,42	32,28	38	24	-	30,5	38	6	9	0,20
22- 5M- 25F	40225022	22	1F	35,01	33,87	39	25,5	-	30,5	38	6	15	0,22
24- 5M- 25F	40225024	24	1F	38,20	37,06	42	27	-	30,5	38	6	13	0,26
26- 5M- 25F	40225026	26	1F	41,38	40,24	44	30	-	30,5	38	6	12	0,32
28- 5M- 25F	40225028	28	1F	44,56	43,42	48	30,5	-	30,5	38	6	11	0,37
30- 5M- 25F	40225030	30	1F	47,75	46,60	51	35	-	30,5	38	6	16	0,42
32- 5M- 25F	40225032	32	1F	50,93	49,79	54	38	-	30,5	38	8	18	0,48
36- 5M- 25F	40225036	36	1F	57,30	56,16	60	38	-	30,5	38	8	21	0,59
40- 5M- 25F	40225040	40	1F	63,66	62,52	71	38	-	30,5	38	8	25	0,75
44- 5M- 25	40225044	44	8	70,03	68,89	-	38	-	30,5	40	8	-	0,32
48- 5M- 25	40225048	48	3	76,39	75,25	-	38	61	30,5	40	8	-	0,28
60- 5M- 25	40225060	60	3	95,49	94,35	-	50	80	30,5	40	8	-	0,44
72- 5M- 25	40225072	72	3	114,59	113,45	-	50	100	30,5	40	8	-	0,85

MATERIAL **STEEL**MATERIAL **ALUMINIUM**

CAD drawings available on our site
www.chiaravalli.com

Quantity, availability and prices
 on B2B Chiaravalli





PHOSPHATED

TYPE **8M 20**

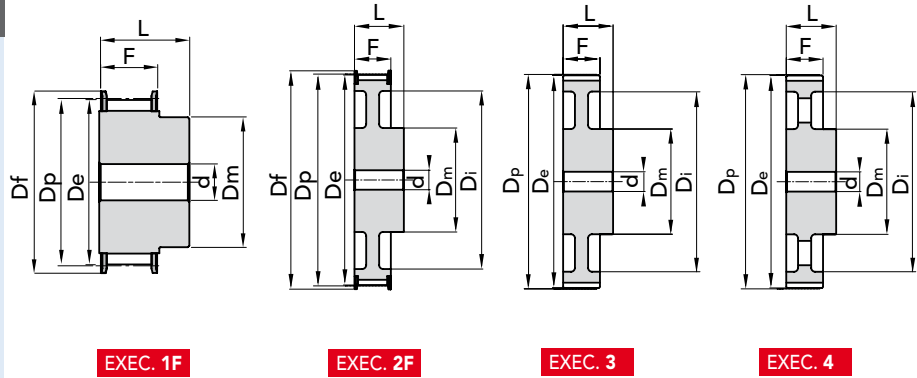

EXEC. 1F

EXEC. 2F

EXEC. 3

EXEC. 4

TYPE	P. NUMBER	N. TEETH	EXEC.	Dp	De	Df FLANGE	Dm HUB	Di	F	L	d Ø Bore	N. FLANGE	WEIGHT kg.
22- 8M- 20F	40420022	22	1F	56,02	54,65	60	43	-	28	38	12	53	0,54
24- 8M- 20F	40420024	24	1F	61,12	59,75	66	45	-	28	38	12	69	0,65
26- 8M- 20F	40420026	26	1F	66,21	64,85	70	48	-	28	38	12	61	0,80
28- 8M- 20F	40420028	28	1F	71,30	70,08	75	50	-	28	38	15	79	0,88
30- 8M- 20F	40420030	30	1F	76,39	75,13	82,5	55	-	28	38	15	64	1,00
32- 8M- 20F	40420032	32	1F	81,49	80,16	87	60	-	28	38	15	76	1,20
34- 8M- 20F	40420034	34	1F	86,58	85,22	91	66	-	28	38	15	66	1,40
36- 8M- 20F	40420036	36	1F	91,67	90,30	97	70	-	28	38	15	68	1,60
38- 8M- 20F	40420038	38	1F	96,77	95,39	102	75	-	28	38	15	70	1,70
40- 8M- 20F	40420040	40	1F	101,86	100,49	106	75	-	28	38	15	77	1,85
44- 8M- 20F	40420044	44	1F	112,05	110,67	120	75	-	28	38	15	75	2,10
48- 8M- 20F	40420048	48	1F	122,23	120,86	128	75	-	28	38	15	78	2,50
56- 8M- 20F	40420056	56	2F	142,60	141,23	150	80	116	28	38	15	85	2,82
64- 8M- 20F	40420064	64	2F	162,97	161,60	168	80	137	28	38	15	90	3,22
72- 8M- 20F	40420072	72	2F	183,35	181,97	192	80	158	28	38	15	97	3,74
80- 8M- 20	40420080	80	3	203,72	202,35	-	90	180	28	38	15	-	3,78
90- 8M- 20	40420090	90	3	229,18	227,81	-	90	204	28	38	15	-	4,57
112- -8M- 20	on demand	112	4	285,21	283,83	-	90	254	28	38	18	-	-
144- 8M- 20	40420144	144	4	366,69	365,32	-	90	336	28	38	20	-	5,20
168- 8M- 20	on demand	168	4	427,81	426,44	-	100	400	28	38	20	-	-
192- 8M- 21	on demand	192	4	488,92	487,55	-	100	460	28	38	20	-	-

HTD® TIMING PULLEYS with PILOT BORE "PHOSPHATED" 8M 20

7

MATERIAL **STEEL**

MATERIAL **CAST-IRON**

CAD drawings available on our site
www.chiaravalli.com

Quantity, availability and prices
on B2B Chiaravalli

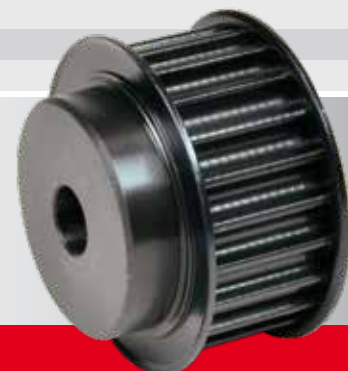

The images do not identify the products.

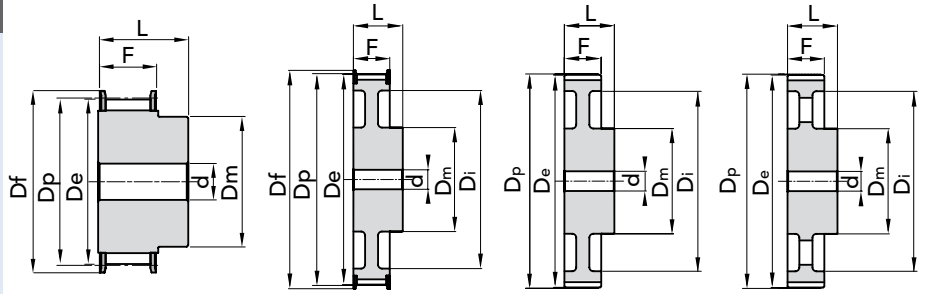

PHOSPHATED

TYPE **8M 30**

EXEC. 1F

EXEC. 2F

EXEC. 3

EXEC. 4

TYPE	P. NUMBER	N. TEETH	EXEC.	Dp	De	Df FLANGE	Dm HUB	Di	F	L	d Ø Bore	N. FLANGE	WEIGHT kg.
22- 8M- 30F	40430022	22	1F	56,02	54,65	60	43	-	38	48	12	53	0,75
24- 8M- 30F	40430024	24	1F	61,12	59,75	66	45	-	38	48	12	69	0,90
26- 8M- 30F	40430026	26	1F	66,21	64,85	70	48	-	38	48	12	61	1,10
28- 8M- 30F	40430028	28	1F	71,30	70,08	75	50	-	38	48	15	79	1,20
30- 8M- 30F	40430030	30	1F	76,39	75,13	82,5	55	-	38	48	15	73	1,32
32- 8M- 30F	40430032	32	1F	81,49	80,16	87	60	-	38	48	15	76	1,55
34- 8M- 30F	40430034	34	1F	86,58	85,22	91	66	-	38	48	15	66	1,80
36- 8M- 30F	40430036	36	1F	91,67	90,30	97	70	-	38	48	15	68	2,10
38- 8M- 30F	40430038	38	1F	96,77	95,39	102	75	-	38	48	15	70	2,30
40- 8M- 30F	40430040	40	1F	101,86	100,49	106	75	-	38	48	15	77	2,47
44- 8M- 30F	40430044	44	1F	112,05	110,67	120	75	-	38	48	15	75	2,95
48- 8M- 30F	40430048	48	1F	122,23	120,86	128	75	-	38	48	15	78	3,30
56- 8M- 30F	40430056	56	2F	142,60	141,23	150	90	116	38	48	15	85	4,02
64- 8M- 30F	40430064	64	2F	162,97	161,60	168	90	137	38	48	15	90	4,60
72- 8M- 30F	40430072	72	2F	183,35	181,97	192	95	158	38	48	15	97	5,41
80- 8M- 30	40430080	80	3	203,72	202,35	-	100	180	38	48	15	-	5,23
90- 8M- 30	40430090	90	3	229,18	227,81	-	100	204	38	48	15	-	6,42
112- 8M- 30	40430112	112	4	285,21	283,83	-	100	254	38	48	18	-	8,12
144- 8M- 30	40430144	144	4	366,69	365,32	-	100	336	38	48	20	-	10,36
168- 8M- 30	40430168	168	4	427,81	426,44	-	100	400	38	48	20	-	12,37
192- 8M- 30	40430192	192	4	488,92	487,55	-	100	460	38	48	20	-	14,31

MATERIAL **STEEL**MATERIAL **CAST-IRON**
 CAD drawings available on our site
www.chiaravalli.com

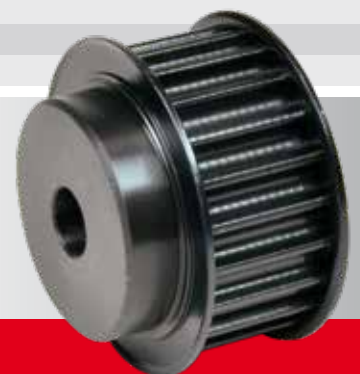
 Quantity, availability and prices
 on B2B Chiaravalli



PHOSPHATED

TYPE **8M 50**

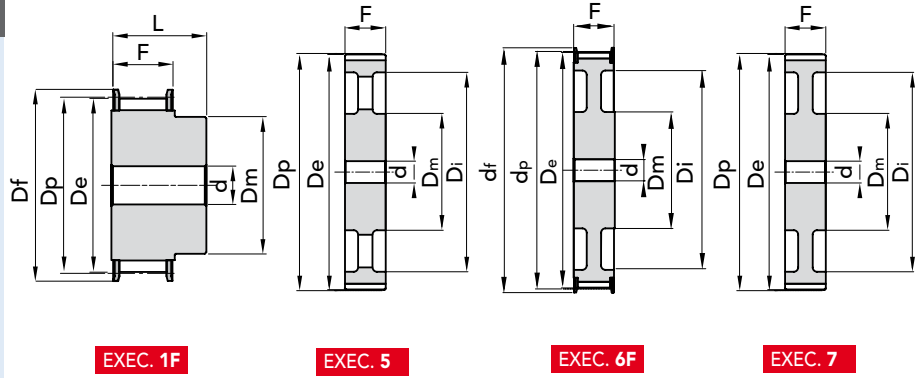

EXEC. 1F

EXEC. 5

EXEC. 6F

EXEC. 7

TYPE	P. NUMBER	N. TEETH	EXEC.	Dp	De	Df FLANGE	Dm HUB	Di	F	L	d Ø Bore	N. FLANGE	WEIGHT kg.
22- 8M- 50F	40450022	22	1F	56,02	54,65	60	43	-	60	70	-	53	1,10
24- 8M- 50F	40450024	24	1F	61,12	59,75	66	45	-	60	70	-	69	1,20
26- 8M- 50F	40450026	26	1F	66,21	64,85	70	48	-	60	70	-	61	1,60
28- 8M- 50F	40450028	28	1F	71,30	70,08	75	50	-	60	70	-	79	1,70
30- 8M- 50F	40450030	30	1F	76,39	75,13	82,5	55	-	60	70	-	73	2,00
32- 8M- 50F	40450032	32	1F	81,49	80,16	87	60	-	60	70	-	76	2,35
34- 8M- 50F	40450034	34	1F	86,58	85,22	91	66	-	60	70	-	66	2,80
36- 8M- 50F	40450036	36	1F	91,67	90,30	97	70	-	60	70	-	68	3,10
38- 8M- 50F	40450038	38	1F	96,77	95,39	102	75	-	60	70	-	70	3,30
40- 8M- 50F	40450040	40	1F	101,86	100,49	106	75	-	60	70	-	77	3,60
44- 8M- 50F	40450044	44	1F	112,05	110,67	120	75	-	60	70	-	75	4,40
48- 8M- 50F	40450048	48	1F	122,23	120,86	128	80	-	60	70	-	78	5,00
56- 8M- 50F	40450056	56	6F	142,60	141,23	150	90	116	60	60	18	85	5,68
64- 8M- 50F	40450064	64	6F	162,97	161,60	168	100	137	60	60	18	90	6,93
72- 8M- 50F	40450072	72	6F	183,35	181,97	192	100	158	60	60	18	97	7,95
80- 8M- 50	40450080	80	7	203,72	202,35	-	110	180	60	60	18	-	7,96
90- 8M- 50	40450090	90	7	229,18	227,81	-	110	204	60	60	18	-	9,20
112- 8M- 50	40450112	112	5	285,21	283,83	-	110	254	60	60	18	-	12,16
144- 8M- 50	40450144	144	5	366,69	365,32	-	110	336	60	60	20	-	15,68
168- 8M- 50	40450168	168	5	427,81	426,44	-	120	400	60	60	20	-	18,99
192- 8M- 50	40450192	192	5	488,92	487,55	-	130	460	60	60	20	-	21,09

HTD® TIMING PULLEYS with PILOT BORE "PHOSPHATED" 8M 50

7

MATERIAL **STEEL**

MATERIAL **CAST-IRON**

CAD drawings available on our site
www.chiaravalli.com

Quantity, availability and prices
on B2B Chiaravalli

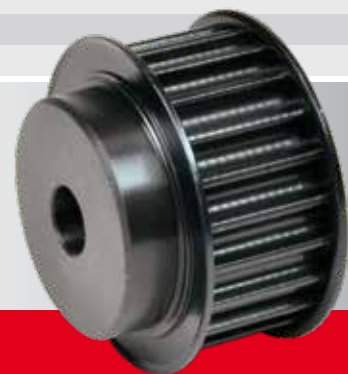

The images do not identify the products.

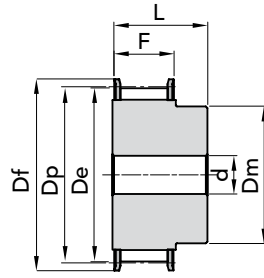

PHOSPHATED

TYPE **8M 85**

EXEC. 1F

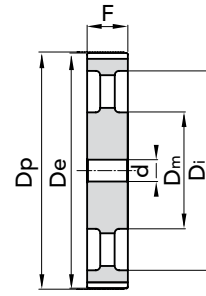

EXEC. 5

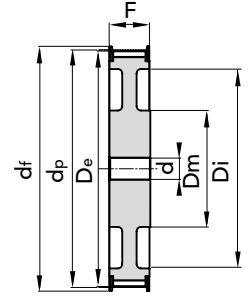

EXEC. 6F

TYPE	P. NUMBER	N. TEETH	EXEC.	Dp	De	Df FLANGE	Dm HUB	Di	F	L	d Ø Bore	N. FLANGE	WEIGHT kg.
22- 8M- 85F	40485022	22	1F	56,02	54,65	60	43	-	95	105	-	53	1,60
24- 8M- 85F	40485024	24	1F	61,12	59,75	66	45	-	95	105	-	69	1,95
26- 8M- 85F	40485026	26	1F	66,21	64,85	70	48	-	95	105	-	61	2,30
28- 8M- 85F	40485028	28	1F	71,30	70,08	75	50	-	95	105	-	79	2,60
30- 8M- 85F	40485030	30	1F	76,39	75,13	82,5	55	-	95	105	-	73	3,10
32- 8M- 85F	40485032	32	1F	81,49	80,16	87	60	-	95	105	-	76	3,70
34- 8M- 85F	40485034	34	1F	86,58	85,22	91	66	-	95	105	-	66	4,00
36- 8M- 85F	40485036	36	1F	91,67	90,30	97	70	-	95	105	-	68	4,70
38- 8M- 85F	40485038	38	1F	96,77	95,39	102	75	-	95	105	-	70	5,10
40- 8M- 85F	40485040	40	1F	101,86	100,49	106	75	-	95	105	-	77	5,40
44- 8M- 85F	40485044	44	1F	112,05	110,67	120	75	-	95	105	-	75	6,70
48- 8M- 85F	40485048	48	1F	122,23	120,86	128	80	-	95	105	-	78	7,20
56- 8M- 85F	40485056	56	1F	142,60	141,23	150	90	-	95	105	20	85	11,48
64- 8M- 85F	40485064	64	6F	162,97	161,60	168	100	137	95	95	20	90	11,02
72- 8M- 85F	40485072	72	6F	183,35	181,97	192	100	158	95	95	20	97	13,45
80- 8M- 85	40485080	80	5	203,72	202,35	-	110	180	95	95	20	-	12,36
90- 8M- 85	40485090	90	5	229,18	227,81	-	110	204	95	95	20	-	14,38
112- 8M- 85	40485112	112	5	285,21	283,83	-	110	254	95	95	24	-	18,66
144- 8M- 85	40485144	144	5	366,69	365,32	-	110	336	95	95	24	-	23,00
168- 8M- 85	on demand	168	5	427,81	426,44	-	120	400	95	95	24	-	-
192- 8M- 85	on demand	192	5	488,92	487,55	-	130	460	95	95	24	-	-

MATERIAL **STEEL**MATERIAL **CAST-IRON**
 CAD drawings available on our site
www.chiaravalli.com

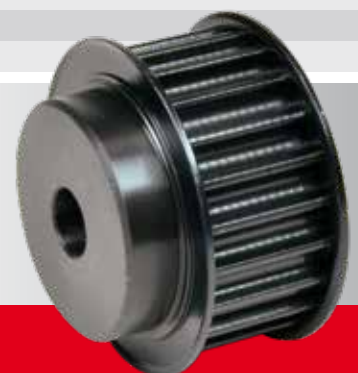
 Quantity, availability and prices
 on B2B Chiaravalli



PHOSPHATED

TYPE **14M 40**

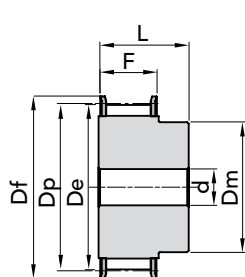

EXEC. 1F

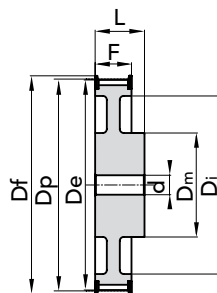

EXEC. 2F

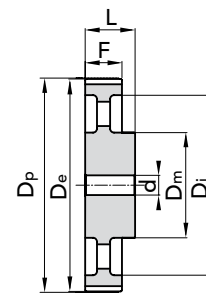

EXEC. 4

TYPE	P. NUMBER	N. TEETH	EXEC.	Dp	De	Df FLANGE	Dm HUB	Di	F	L	d Ø Bore	N. FLANGE	WEIGHT kg.
28-14M- 40F	40640028	28	1F	124,78	122,12	128	100	-	54	69	24	153	4,80
29-14M- 40F	40640029	29	1F	129,23	126,57	138	100	-	54	69	24	154	5,20
30-14M- 40F	40640030	30	1F	133,69	130,99	138	100	-	54	69	24	154	5,60
32-14M- 40F	40640032	32	1F	142,60	139,88	154	100	-	54	69	24	160	6,20
34-14M- 40F	40640034	34	1F	151,52	148,79	160	100	-	54	69	24	166	6,90
36-14M- 40F	40640036	36	1F	160,43	157,68	168	100	-	54	69	24	168	7,70
38-14M- 40F	40640038	38	1F	169,34	166,60	183	120	-	54	69	24	172	8,90
40-14M- 40F	40640040	40	1F	178,25	175,49	188	120	-	54	69	24	162	9,80
44-14M- 40F	40640044	44	1F	196,08	193,28	211	120	-	54	69	24	175	12,00
48-14M- 40F	40640048	48	2F	213,90	211,11	226	135	170	54	69	24	180	11,98
56-14M- 40F	40640056	56	2F	249,55	246,76	256	135	207	54	69	28	182	14,01
64-14M- 40F	40640064	64	2F	285,21	282,41	296	135	240	54	69	28	184	16,65
72-14M- 40	40640072	72	4	320,86	318,06	-	135	278	54	69	28	-	15,52
80-14M- 40	40640080	80	4	356,51	353,71	-	135	314	54	69	28	-	17,23
90-14M- 40	40640090	90	4	401,07	398,28	-	135	358	54	69	28	-	19,40
112-14M- 40	40640112	112	4	499,11	496,32	-	135	456	54	69	28	-	24,14
144-14M-40	on demand	144	4	641,71	638,92	-	135	600	54	69	28	-	-
168-14M-40	on demand	168	4	748,66	745,87	-	135	706	54	69	28	-	-
192-14M-40	on demand	192	4	855,62	852,82	-	135	813	54	69	28	-	-
216-14M-40	on demand	216	4	962,57	959,76	-	150	920	54	69	28	-	-

MATERIAL **STEEL**

MATERIAL **CAST-IRON**

CAD drawings available on our site
www.chiaravalli.com

Quantity, availability and prices
on B2B Chiaravalli



The images do not identify the products.

HTD® TIMING PULLEYS with PILOT BORE "PHOSPHATED" 14M 40

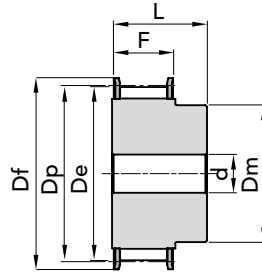

PHOSPHATED

TYPE **14M 55**

EXEC. 1F

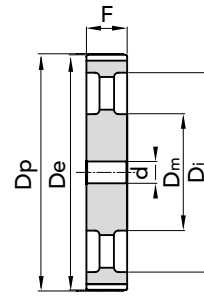

EXEC. 5

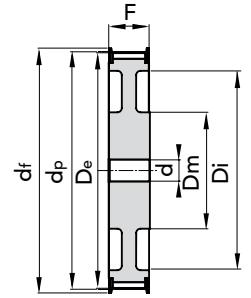

EXEC. 6F

TYPE	P. NUMBER	N. TEETH	EXEC.	Dp	De	Df FLANGE	Dm HUB	Di	F	L	d Ø Bore	N. FLANGE	WEIGHT kg.
28-14M- 55F	40655028	28	1F	124,78	122,12	128	100	-	70	85	24	153	5,70
29-14M- 55F	40655029	29	1F	129,23	126,57	138	100	-	70	85	24	154	6,40
30-14M- 55F	40655030	30	1F	133,69	130,99	138	100	-	70	85	24	154	7,10
32-14M- 55F	40655032	32	1F	142,60	139,88	154	100	-	70	85	24	160	7,90
34-14M- 55F	40655034	34	1F	151,52	148,79	160	100	-	70	85	24	166	9,33
36-14M- 55F	40655036	36	1F	160,43	157,68	168	100	-	70	85	24	168	10,49
38-14M- 55F	40655038	38	1F	169,34	166,60	183	120	-	70	85	24	172	12,11
39- 14M- 55F													
40-14M- 55F	40655040	40	1F	178,25	175,49	188	120	-	70	85	24	162	13,00
44-14M- 55F	40655044	44	1F	196,08	193,28	211	120	-	70	85	24	175	16,12
48-14M- 55F	40655048	48	6F	213,90	211,11	226	135	170	70	70	24	180	13,50
56-14M- 55F	40655056	56	6F	249,55	246,76	256	135	207	70	70	28	182	15,78
64-14M- 55F	40655064	64	6F	285,21	282,41	296	135	240	70	70	28	184	19,04
72-14M- 55	40655072	72	5	320,86	318,06	-	135	278	70	70	28	-	18,41
80-14M- 55	40655080	80	5	356,51	353,71	-	135	314	70	70	28	-	20,27
90-14M- 55	40655090	90	5	401,07	398,28	-	135	358	70	70	28	-	22,98
112-14M- 55	40655112	112	5	499,11	496,32	-	135	456	70	70	28	-	29,29
144-14M- 55	40655144	144	5	641,71	638,92	-	135	600	70	70	28	-	36,00
168-14M- 55	40655168	168	5	748,66	745,87	-	135	706	70	70	28	-	40,00
192-14M- 55	40655192	192	5	855,62	852,82	-	135	813	70	70	28	-	47,50
216-14M- 55	on demand	216	5	962,57	959,76	-	150	920	70	70	28	-	-

MATERIAL **STEEL**MATERIAL **CAST-IRON**
 CAD drawings available on our site
www.chiaravalli.com

 Quantity, availability and prices
 on B2B Chiaravalli



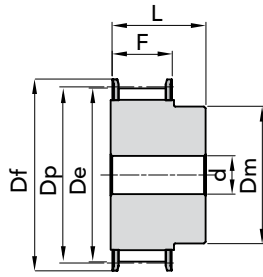

PHOSPHATED

TYPE **14M 85**

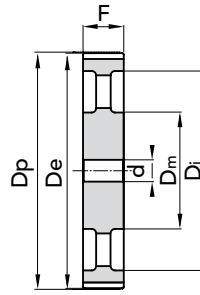

EXEC. 1F



EXEC. 5

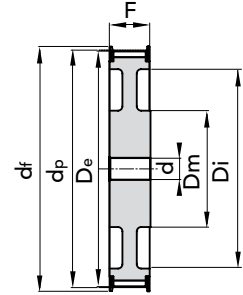

EXEC. 6F

TYPE	P. NUMBER	N. TEETH	EXEC.	Dp	De	Df FLANGE	Dm HUB	Di	F	L	d Ø Bore	N. FLANGE	WEIGHT kg.
28-14M- 85F	40685028	28	1F	124,78	122,12	128	100	-	102	117	-	153	8,77
29-14M- 85F	on demand	29	1F	129,23	126,57	138	100	-	102	117	-	154	-
30-14M- 85F	40685030	30	1F	133,69	130,99	138	100	-	102	117	-	154	9,45
32-14M- 85F	40685032	32	1F	142,60	139,88	154	100	-	102	117	-	160	10,13
34-14M- 85F	40685034	34	1F	151,52	148,79	160	100	-	102	117	-	166	11,65
36-14M- 85F	40685036	36	1F	160,43	157,68	168	100	-	102	117	-	168	14,48
38-14M- 85F	40685038	38	1F	169,34	166,60	183	120	-	102	117	-	172	16,62
40-14M- 85F	40685040	40	1F	178,25	175,49	188	135	-	102	117	-	162	18,84
44-14M- 85F	40685044	44	1F	196,08	193,28	211	135	-	102	117	-	175	23,00
48-14M- 85F	40685048	48	1F	213,90	211,11	226	150	-	102	117	-	180	27,58
56-14M- 85F	40685056	56	6F	249,55	246,76	256	150	207	102	102	32	182	24,19
64-14M- 85F	40685064	64	6F	285,21	282,41	296	150	240	102	102	32	184	28,57
72-14M- 85	40685072	72	5	320,86	318,06	-	150	278	102	102	32	-	28,26
80-14M- 85	40685080	80	5	356,51	353,71	-	150	314	102	102	32	-	31,00
90-14M- 85	40685090	90	5	401,07	398,28	-	150	358	102	102	32	-	35,00
112-14M- 85	40685112	112	5	499,11	496,32	-	150	456	102	102	32	-	43,50
144-14M- 85	40685144	144	5	641,71	638,92	-	150	600	102	102	32	-	50,00
168-14M- 85	40685168	168	5	748,66	745,87	-	150	706	102	102	32	-	63,00
192-14M- 85	40685192	192	5	855,62	852,82	-	165	813	102	102	32	-	76,00
216-14M- 85	on demand	216	5	962,57	959,76	-	165	920	102	102	32	-	-

MATERIAL **STEEL**

MATERIAL **CAST-IRON**

CAD drawings available on our site
www.chiaravalli.com

Quantity, availability and prices
on B2B Chiaravalli



The images do not identify the products.

HTD® TIMING PULLEYS with PILOT BORE "PHOSPHATED" 14M 85

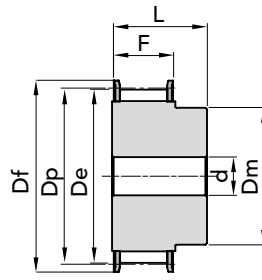

PHOSPHATED

TYPE **14M 115**

EXEC. 1F

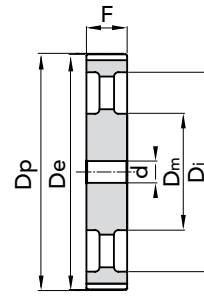

EXEC. 5

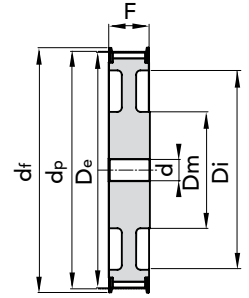

EXEC. 6F

TYPE	P. NUMBER	N. TEETH	EXEC.	Dp	De	Df FLANGE	Dm HUB	Di	F	L	d Ø Bore	N. FLANGE	WEIGHT kg.
28-14M- 115F	40690028	28	1F	124,78	122,12	128	100	-	133	148	-	153	11,00
29-14M- 115F	on demand	29	1F	129,23	126,57	138	100	-	133	148	-	154	-
30-14M- 115F	40690030	30	1F	133,69	130,99	138	100	-	133	148	-	154	12,52
32-14M- 115F	40690032	32	1F	142,60	139,88	154	100	-	133	148	-	160	14,48
34-14M- 115F	40690034	34	1F	151,52	148,79	160	100	-	133	148	-	166	16,45
36-14M- 115F	40690036	36	1F	160,43	157,68	168	120	-	133	148	-	168	18,99
38-14M- 115F	40690038	38	1F	169,34	166,60	183	120	-	133	148	-	172	21,31
40-14M- 115F	40690040	40	1F	178,25	175,49	188	135	-	133	148	-	162	24,04
44-14M- 115F	40690044	44	1F	196,08	193,28	211	140	-	133	148	-	175	29,00
48-14M- 115F	40690048	48	1F	213,90	211,11	226	150	-	133	148	-	180	35,00
56-14M- 115F	40690056	56	1F	249,55	246,76	256	150	-	133	148	-	182	48,00
64-14M- 115F	40690064	64	6F	285,21	282,41	296	150	240	133	133	32	184	36,00
72-14M- 115	40690072	72	5	320,86	318,06	-	150	278	133	133	32	-	36,00
80-14M- 115	40690080	80	5	356,51	353,71	-	150	314	133	133	32	-	40,00
90-14M- 115	40690090	90	5	401,07	398,28	-	150	358	133	133	32	-	45,00
112-14M- 115	40690112	112	5	499,11	496,32	-	150	456	133	133	32	-	55,50
144-14M- 115	40690144	144	5	641,71	638,92	-	165	600	133	133	32	-	71,00
168-14M- 115	40690168	168	5	748,66	745,87	-	165	706	133	133	32	-	83,00
192-14M- 115	40690192	192	5	855,62	852,82	-	165	813	133	133	32	-	96,00
216-14M- 115	on demand	216	5	962,57	959,76	-	165	920	133	133	32	-	-

MATERIAL **STEEL**MATERIAL **CAST-IRON**
 CAD drawings available on our site
www.chiaravalli.com

 Quantity, availability and prices
 on B2B Chiaravalli



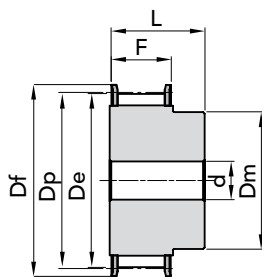

PHOSPHATED

TYPE **14M 170**

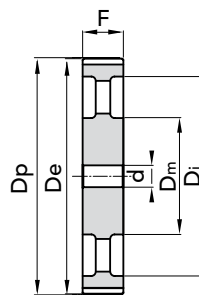

EXEC. 1F



EXEC. 5

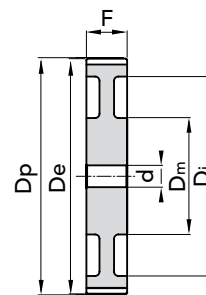

EXEC. 7

TYPE	P. NUMBER	N. TEETH	EXEC.	Dp	De	Df FLANGE	Dm HUB	Di	F	L	d Ø Bore	N. FLANGE	WEIGHT kg.
28-14M- 170F	40692028	28	1F	124,78	122,12	128	100	-	187	202	-	153	14,79
29-14M- 170F	on demand	29	1F	129,23	126,57	138	100	-	187	202	-	154	-
30-14M- 170F	40692030	30	1F	133,69	130,99	138	100	-	187	202	-	154	17,24
32-14M- 170F	40692032	32	1F	142,60	139,88	154	100	-	187	202	-	160	19,92
34-14M- 170F	40692034	34	1F	151,52	148,79	160	100	-	187	202	-	166	22,72
36-14M- 170F	40692036	36	1F	160,43	157,68	168	120	-	187	202	-	168	26,07
38-14M- 170F	40692038	38	1F	169,34	166,60	183	135	-	187	202	-	172	29,71
40-14M- 170F	40692040	40	1F	178,25	175,49	188	140	-	187	202	-	162	33,50
44-14M- 170F	on demand	44	1F	196,08	193,28	211	160	-	187	202	-	175	-
48-14M- 170F	on demand	48	1F	213,90	211,11	226	160	-	187	202	-	180	-
56-14M- 170F	on demand	56	1F	249,55	246,76	256	160	-	187	202	-	182	-
64-14M- 170F	on demand	64	1F	285,21	282,41	296	180	-	187	202	-	184	-
72-14M- 170	on demand	72	7	320,86	318,06	-	180	278	187	187	32	-	-
80-14M- 170	40692080	80	7	356,51	353,71	-	180	314	187	187	32	-	71,00
90-14M- 170	40692090	90	5	401,07	398,28	-	180	358	187	187	38	-	73,00
112-14M- 170	40692112	112	5	499,11	496,32	-	200	456	187	187	38	-	95,00
144-14M- 170	40692144	144	5	641,71	638,92	-	220	600	187	187	38	-	114,00
168-14M- 170	40692168	168	5	748,66	745,87	-	220	706	187	187	38	-	142,00
192-14M- 170	on demand	192	5	855,61	852,82	-	220	813	187	187	38	-	-
216-14M- 170	on demand	216	5	962,57	959,76	-	220	920	187	187	38	-	-

MATERIAL **STEEL**

MATERIAL **CAST-IRON**

CAD drawings available on our site
www.chiaravalli.com

Quantity, availability and prices
on B2B Chiaravalli



The images do not identify the products.

HTD® TIMING PULLEYS with PILOT BORE "PHOSPHATED" 14M 170



HTD® TAPER LOCK® EXECUTIONS TIMING PULLEYS "PHOSPHATED"

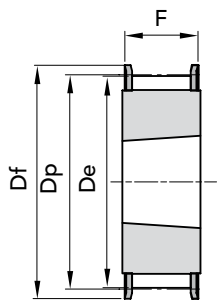

EXEC. 1F

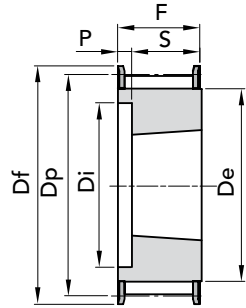

EXEC. 2F

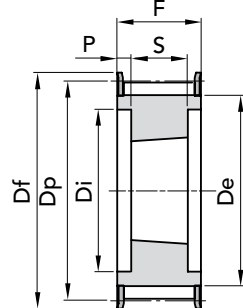

EXEC. 3F

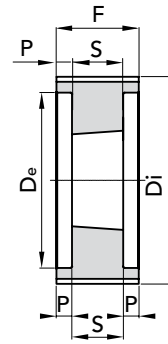

EXEC. 4

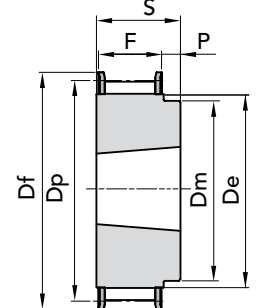

EXEC. 5F

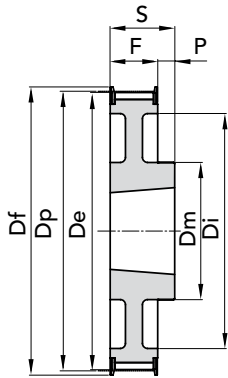

EXEC. 6F

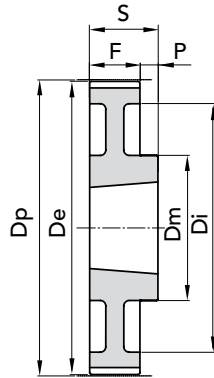

EXEC. 7

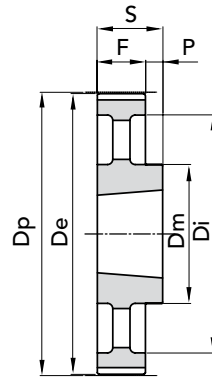

EXEC. 8

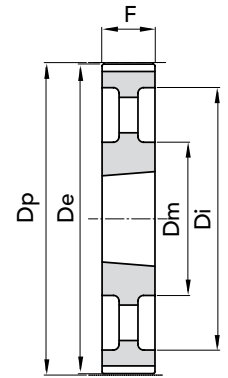

EXEC. 9

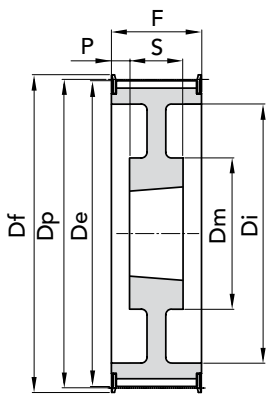

EXEC. 10F

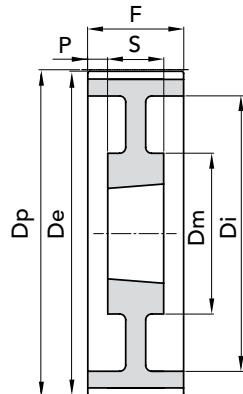

EXEC. 11

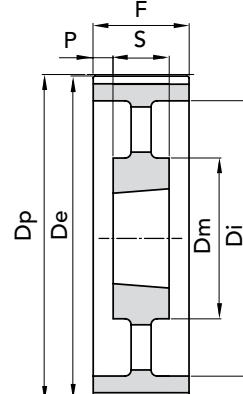

EXEC. 12

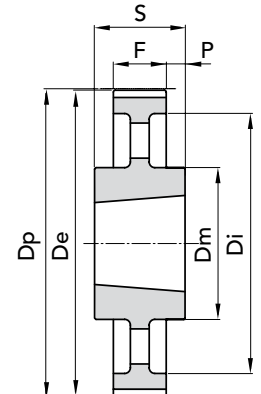

EXEC. 13



TYPE 5M 15

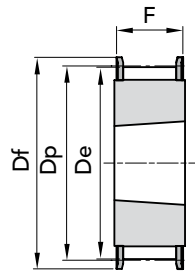

EXEC. 1F

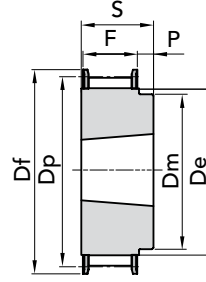

EXEC. 5F

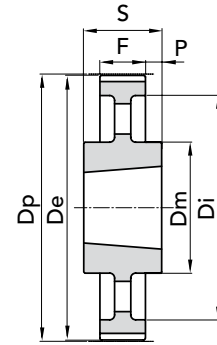

EXEC. 13

TYPE	P. NUMBER	N. TEETH	EXEC.	BUSH.	BORE MAX	Dp	De	Df FLANGE	Dm HUB	Ø Di	F	S	P	N. FLANGE	WEIGHT kg.
TL 34- 5M- 15	41215034	34	1F	1008	25	54,11	52,97	57	-	-	22	22	-	20	0,20
TL 36- 5M- 15	41215036	36	1F	1108	25	57,30	56,15	60	-	-	22	22	-	21	0,25
TL 38- 5M- 15	41215038	38	1F	1108	25	60,48	59,34	66,5	-	-	22	22	-	24	0,30
TL 40- 5M- 15	41215040	40	1F	1108	25	63,66	62,52	71	-	-	22	22	-	25	0,35
TL 44- 5M- 15	41215044	44	1F	1108	25	70,03	68,89	75	-	-	22	22	-	27	0,40
TL 48- 5M- 15	41215048	48	5F	1210	32	76,39	75,25	83	59	-	22	25	3	29	0,46
TL 56- 5M- 15	41215056	56	5F	1210	32	89,13	87,98	93	70	-	22	25	3	33	0,60
TL 64- 5M- 15	41215064	64	5F	1210	32	101,86	100,72	106	80	-	22	25	3	38	0,80
TL 72- 5M- 15	41215072	72	5	1610	42	114,59	113,45	-	92	-	22	25	3	-	1,20
TL 80- 5M- 15	41215080	80	5	1610	42	127,32	126,18	-	92	-	22	25	3	-	1,76
TL 90- 5M- 15	41215090	90	5	1610	42	143,24	142,10	-	92	-	22	25	3	-	2,32
TL 112- 5M- 15	41215112	112	5	2012	50	178,25	177,11	-	110	-	20	32	12	-	3,72
TL 136- 5M- 15	41215136	136	13	2012	50	216,45	215,31	-	110	199	20	32	6	-	3,82

MATERIAL **STEEL**

CAD drawings available on our site
www.chiaravalli.com

Quantity, availability and prices
on B2B Chiaravalli



The images do not identify the products.

HTD® TAPER LOCK® TIMING PULLEYS "PHOSPHATED" 5M 15

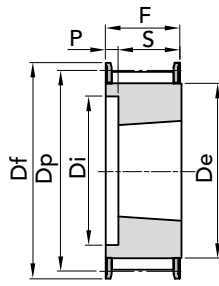
 TYPE **8M 20**

EXEC. 2F

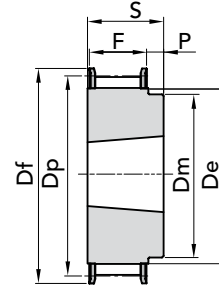

EXEC. 5F

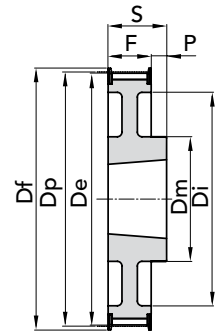

EXEC. 6F

TYPE	P. NUMBER	N. TEETH	EXEC.	BUSH.	BORE MAX	Dp	De	Df FLANGE	Dm HUB	Ø Di	F	S	P	N. FLANGE	WEIGHT kg.
TL 22- 8M- 20	41420022	22	2F	1008	25	56,02	54,65	60	-	37	28	22	6	53	0,25
TL 24- 8M- 20	41420024	24	2F	1108	28	61,12	59,75	66	-	44	28	22	6	69	0,30
TL 26- 8M- 20	41420026	26	2F	1108	28	66,21	64,85	70	-	45	28	22	6	61	0,36
TL 28- 8M- 20	41420028	28	2F	1108	28	71,30	70,08	75	-	50	28	22	6	79	0,45
TL 30- 8M- 20	41420030	30	2F	1108	28	76,39	75,13	82,5	-	58	28	22	6	73	0,55
TL 32- 8M- 20	41420032	32	2F	1610	42	81,49	80,16	87	-	63	28	25	3	76	0,43
TL 34- 8M- 20	41420034	34	2F	1610	42	86,58	85,22	91	-	64	28	25	3	66	0,57
TL 36- 8M- 20	41420036	36	2F	1610	42	91,67	90,30	97	-	68	28	25	3	68	0,70
TL 38- 8M- 20	41420038	38	2F	1610	42	96,77	95,39	102	-	72	28	25	3	70	0,82
TL 40- 8M- 20	41420040	40	2F	1610	42	101,86	100,49	106	-	76	28	25	3	77	1,10
TL 44- 8M- 20	41420044	44	5F	2012	50	112,05	110,67	120	92	-	28	32	4	75	1,20
TL 48- 8M- 20	41420048	48	5F	2012	50	122,23	120,86	128	96	-	28	32	4	78	1,65
TL 56- 8M- 20	41420056	56	5F	2012	50	142,60	141,23	150	110	-	28	32	4	85	2,50
TL 64- 8M- 20	41420064	64	6F	2012	50	162,97	161,60	168	110	137	28	32	4	90	2,60
TL 72- 8M- 20	41420072	72	6F	2012	50	183,35	181,97	192	110	158	28	32	4	97	3,40
TL 80- 8M- 20	41420080	80	7	2012	50	203,72	202,35	-	110	180	28	32	4	-	3,60
TL 90- 8M- 20	41420090	90	7	2012	50	229,18	227,81	-	110	204	28	32	4	-	4,10
TL 112-8M- 20	41420112	112	7	2517	60	285,21	283,83	-	125	254	28	45	17	-	4,57
TL 144- 8M- 20	41420144	144	13	2517	60	366,69	365,32	-	125	336	28	45	12	-	5,00

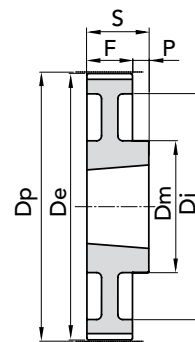

EXEC. 7

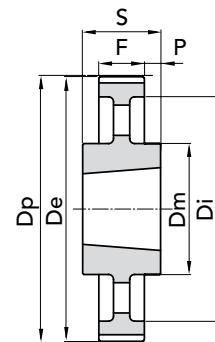

EXEC.13

MATERIAL **STEEL**MATERIAL **CAST-IRON**
 CAD drawings available on our site
www.chiaravalli.com

 Quantity, availability and prices
 on B2B Chiaravalli



TYPE 8M 30

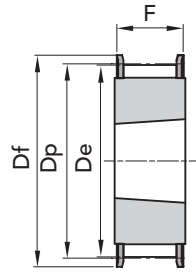

EXEC. 1F

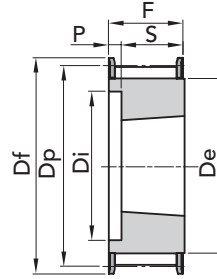

EXEC. 2F

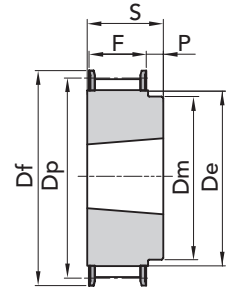

EXEC. 5F

TYPE	P. NUMBER	N. TEETH	EXEC.	BUSH.	BORE MAX	Dp	De	Df FLANGE	Dm HUB	Ø Di	F	S	P	N. FLANGE	WEIGHT kg.
TL 22- 8M- 30	41430022	22	2F	1008	25	56,02	54,65	60	-	37	38	22	16	53	0,33
TL 24- 8M- 30	41430024	24	2F	1108	28	61,12	59,75	66	-	44	38	22	16	69	0,40
TL 26- 8M- 30	41430026	26	2F	1108	28	66,21	64,85	70	-	44	38	22	16	61	0,45
TL 28- 8M- 30	41430028	28	2F	1210	32	71,30	70,08	75	-	50	38	25	13	79	0,50
TL 30- 8M- 30	41430030	30	1F	1615	42	76,39	75,13	82,5	-	-	38	38	-	73	0,55
TL 32- 8M- 30	41430032	32	1F	1615	42	81,49	80,16	87	-	-	38	38	-	76	0,60
TL 34- 8M- 30	41430034	34	1F	1615	42	86,58	85,22	91	-	-	38	38	-	66	0,80
TL 36- 8M- 30	41430036	36	1F	1615	42	91,57	90,30	97	-	-	38	38	-	68	1,00
TL 38- 8M- 30	41430038	38	1F	1615	42	96,77	95,39	102	-	-	38	38	-	70	1,10
TL 40- 8M- 30	41430040	40	1F	1615	42	101,86	100,49	106	-	-	38	38	-	77	1,34
TL 44- 8M- 30	41430044	44	2F	2012	50	112,05	110,67	120	-	86	38	32	6	75	1,30
TL 48- 8M- 30	41430048	48	2F	2012	50	122,23	120,86	128	-	90	38	32	6	78	1,80
TL 56- 8M- 30	41430056	56	2F	2012	50	142,60	141,23	150	-	110	38	32	6	85	3,80
TL 64- 8M- 30	41430064	64	5F	2517	60	162,97	161,60	168	125	-	38	45	7	90	4,30
TL 72- 8M- 30	41430072	72	6F	2517	60	183,35	181,97	192	125	158	38	45	7	97	4,40
TL 80- 8M- 30	41430080	80	7	2517	60	203,72	202,35	-	125	180	38	45	7	-	4,65
TL 90- 8M- 30	41430090	90	7	2517	60	229,18	227,81	-	125	204	38	45	7	-	5,80
TL 112-8M- 30	41430112	112	7	2517	60	285,21	283,83	-	125	254	38	45	7	-	6,20
TL 144- 8M- 30	41430144	144	8	2517	60	366,69	365,32	-	125	336	38	45	7	-	9,00
TL 168- 8M- 30	41430168	168	8	2517	60	427,81	426,44	-	125	395	38	45	7	-	11,80
TL 192- 8M- 30	41430192	192	13	3525	60	488,92	487,55	-	198	455	38	65	13,5	-	14,00

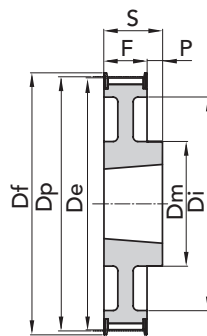

EXEC. 6F

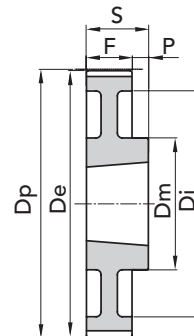

EXEC. 7

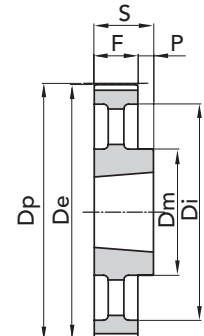

EXEC. 8

MATERIAL **STEEL**

MATERIAL **CAST-IRON**

CAD drawings available on our site
www.chiaravalli.com

Quantity, availability and prices
 on B2B Chiaravalli



The images do not identify the products.

HTD® TAPER LOCK® TIMING PULLEYS "PHOSPHATED" 8M 30



TYPE 8M 50

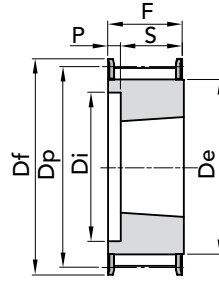

EXEC. 2F

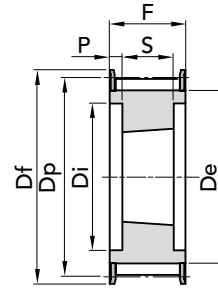

EXEC. 3F

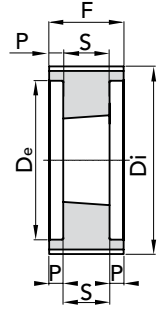

EXEC. 4

TYPE	P. NUMBER	N. TEETH	EXEC.	BUSH.	BORE MAX	Dp	De	Df FLANGE	Dm HUB	Ø Di	F	S	P	N. FLANGE	WEIGHT kg.
TL 28- 8M- 50	41450028	28	2F	1210	32	71,30	70,08	75	-	50	60	25	35	79	0,60
TL 30- 8M- 50	41450030	30	2F	1615	42	76,39	75,13	82,5	-	58	60	38	22	73	0,65
TL 32- 8M- 50	41450032	32	2F	1615	42	81,49	80,16	87	-	63	60	38	22	76	0,80
TL 34- 8M- 50	41450034	34	2F	1615	42	86,58	85,22	91	-	65	60	38	22	66	1,08
TL 36- 8M- 50	41450036	36	2F	1615	42	91,67	90,30	97	-	68	60	38	22	68	1,35
TL 38- 8M- 50	41450038	38	2F	1615	42	96,77	95,39	102	-	72	60	38	22	70	1,65
TL 40- 8M- 50	41450040	40	3F	2012	50	101,86	100,49	106	-	80	60	32	14	77	1,70
TL 44- 8M- 50	41450044	44	3F	2012	50	112,05	110,67	120	-	86	60	32	14	75	1,80
TL 48- 8M- 50	41450048	48	3F	2012	50	122,23	120,86	128	-	95	60	32	14	78	2,35
TL 56- 8M- 50	41450056	56	3F	2517	60	142,60	141,23	150	-	116	60	45	7,5	85	3,35
TL 64- 8M- 50	41450064	64	3F	2517	60	162,97	161,60	168	-	136	60	45	7,5	90	4,90
TL 72- 8M- 50	41450072	72	10F	2517	60	183,35	181,97	192	125	158	60	45	7,5	97	6,90
TL 80- 8M- 50	41450080	80	4	3020	75	203,72	202,30	-	-	180	60	51	4,5	-	8,90
TL 90- 8M- 50	41450090	90	11	3020	75	229,18	227,81	-	160	204	60	51	4,5	-	9,90
TL 112- 8M- 50	41450112	112	11	3020	75	285,21	283,83	-	170	254	60	51	4,5	-	12,10
TL 144- 8M- 50	41450144	144	12	3020	75	366,69	365,32	-	170	336	60	51	4,5	-	15,40
TL 168- 8M- 50	41450168	168	13	3525	90	427,81	426,44	-	198	395	60	65	2,5	-	22,80
TL 192- 8M- 50	41450192	192	13	3525	90	488,92	487,55	-	198	455	60	65	2,5	-	26,50

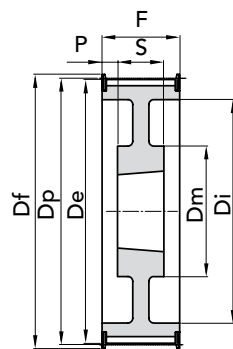

EXEC. 10F

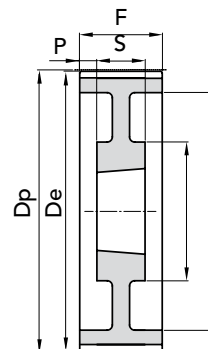

EXEC. 11

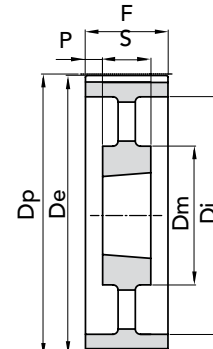

EXEC. 12

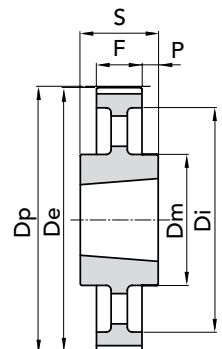

EXEC. 13

MATERIAL **STEEL**

MATERIAL **CAST-IRON**

CAD drawings available on our site
www.chiaravalli.com

Quantity, availability and prices
 on B2B Chiaravalli



TYPE 8M 85

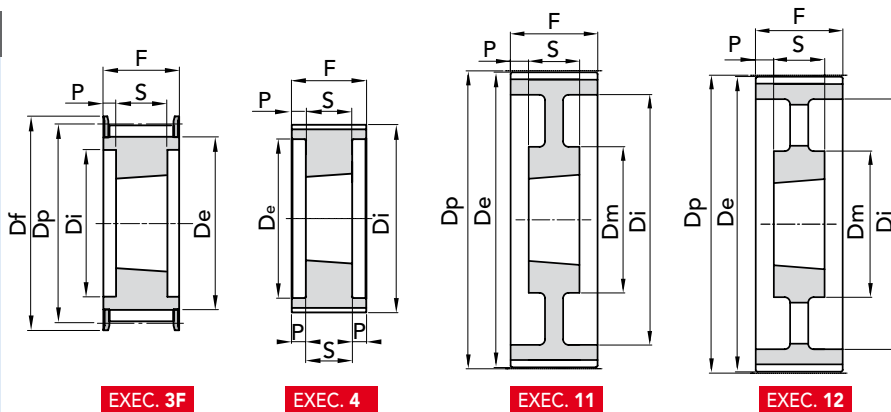

EXEC. 3F

EXEC. 4

EXEC. 11

EXEC. 12

TYPE	P. NUMBER	N. TEETH	EXEC.	BUSH.	BORE MAX	Dp	De	Df FLANGE	Dm HUB	Ø Di	F	S	P	N. FLANGE	WEIGHT kg.
TL 34- 8M- 85	41485034	34	3F	1615	42	86,58	85,22	91	-	65	95	38	28,5	66	1,50
TL 36- 8M- 85	41485036	36	3F	1615	42	91,67	90,30	97	-	68	95	38	28,5	68	1,90
TL 38- 8M- 85	41485038	38	3F	1615	42	96,77	95,39	102	-	72	95	38	28,5	70	2,20
TL 40- 8M- 85	41485040	40	3F	2012	50	101,86	100,49	106	-	80	95	32	31,5	77	1,90
TL 44- 8M- 85	41485044	44	3F	2012	50	112,05	110,67	120	-	86	95	32	31,5	75	2,30
TL 48- 8M- 85	41485048	48	3F	2517	60	122,23	120,86	128	-	97	95	45	25	78	2,70
TL 56- 8M- 85	41485056	56	3F	2517	60	142,60	141,23	150	-	116	95	45	25	85	4,50
TL 64- 8M- 85	41485064	64	3F	2517	60	162,97	161,60	168	-	136	95	45	25	90	6,30
TL 72- 8M- 85	41485072	72	3F	3020	75	183,35	181,97	192	-	150	95	51	22	97	8,10
TL 80- 8M- 85	41485080	80	4	3020	75	203,72	202,35	-	-	180	95	51	22	-	10,20
TL 90- 8M- 85	41485090	90	4	3020	75	229,18	227,81	-	-	204	95	51	22	-	11,20
TL 112- 8M- 85	41485112	112	11	3020	75	285,21	283,83	-	170	254	95	51	22	-	15,00
TL 144- 8M- 85	41485144	144	11	3525	90	366,69	365,32	-	198	336	95	65	15	-	20,20
TL 168- 8M- 85	41485168	168	12	3525	90	427,81	426,44	-	198	395	95	65	15	-	22,40
TL 192- 8M- 85	41485192	192	12	3525	90	488,92	487,55	-	198	455	95	65	15	-	28,20

MATERIAL **STEEL**

MATERIAL **CAST-IRON**

CAD drawings available on our site
www.chiaravalli.com

Quantity, availability and prices
 on B2B Chiaravalli

HTD® TAPER LOCK® TIMING PULLEYS "PHOSPHATED" 8M 85

The images do not identify the products.

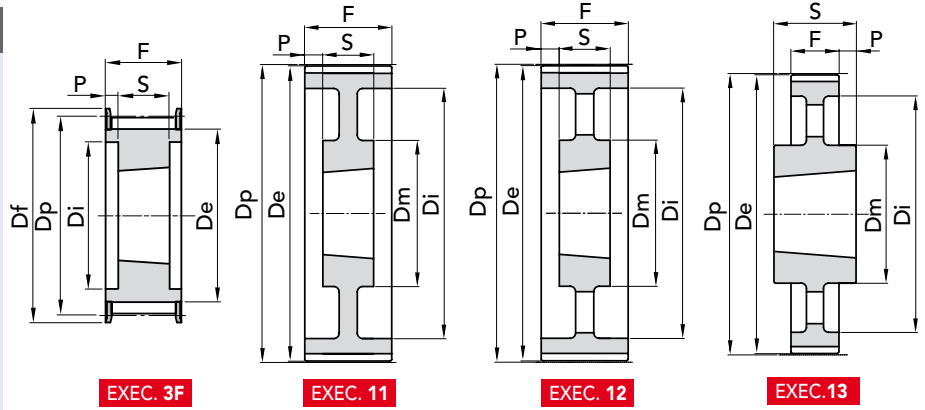
 TYPE **14M 40**

TYPE	P. NUMBER	N. TEETH	EXEC.	BUSH.	BORE MAX	Dp	De	Df FLANGE	Dm HUB	Ø Di	F	S	P	N. FLANGE	WEIGHT kg.
TL 28-14M- 40	41640028	28	3F	2012	50	124,78	122,12	128	-	94	54	32	11	153	2,10
TL 29-14M- 40	41640029	29	3F	2012	50	129,23	126,57	138	-	96	54	32	11	154	2,40
TL 30-14M- 40	41640030	30	3F	2012	50	133,69	139,99	138	-	98	54	32	11	154	2,70
TL 32-14M- 40	41640032	32	3F	2012	50	142,60	139,88	154	-	108	54	32	11	160	3,40
TL 34-14M- 40	41640034	34	3F	2517	60	151,52	148,79	160	-	110	54	45	4,5	166	3,90
TL 36-14M- 40	41640036	36	3F	2517	60	160,43	157,68	168	-	120	54	45	4,5	168	4,80
TL 38-14M- 40	41640038	38	3F	2517	60	169,34	166,60	183	-	130	54	45	4,5	172	5,40
TL 40-14M- 40	41640040	40	3F	2517	60	178,25	175,49	188	-	138	54	45	4,5	162	6,00
TL 42-14M- 40	41640042	42	3F	3020	75	187,16	184,37	200	-	147	54	51	1,5	SP	7,50
TL 44-14M- 40	41640044	44	3F	3020	75	196,08	193,28	211	-	155	54	51	1,5	175	9,00
TL 48-14M- 40	41640048	48	3F	3020	75	213,90	211,11	226	-	170	54	51	1,5	180	10,10
TL 56-14M- 40	41640056	56	3F	3020	75	249,55	246,76	256	-	208	54	51	1,5	182	13,40
TL 72-14M- 40	41640072	72	11	3020	75	320,86	318,06	-	170	280	54	51	1,5	-	15,00
TL 80-14M- 40	41640080	80	12	3020	75	356,51	353,71	-	170	315	54	51	1,5	-	16,00
TL 90-14M- 40	41640090	90	12	3020	75	401,70	398,28	-	170	360	54	51	1,5	-	18,00
TL 112-14M- 40	41640112	112	12	3020	75	499,11	496,32	-	170	457	54	51	1,5	-	25,50
TL 144-14M- 40	41640144	144	12	3020	75	641,71	638,92	-	170	600	54	51	1,5	-	32,00
TL 168-14M- 40	41640168	168	12	3020	75	748,66	745,87	-	170	706	54	51	1,5	-	53,60
TL 192-14M- 40	41640192	192	12	3020	75	855,62	852,82	-	170	813	54	51	1,5	-	65,40
TL 216-14M- 40	41640216	216	12	3020	75	962,57	959,76	-	170	920	54	51	1,5	-	87,30
TL 264-14M- 40	41640264	264	13	4040	100	1176,47	1173,66	-	230	1133	54	102	24	-	131,0

 MATERIAL **STEEL**

 MATERIAL **CAST-IRON**

 CAD drawings available on our site
www.chiaravalli.com

 Quantity, availability and prices
 on B2B Chiaravalli



TYPE 14M 55

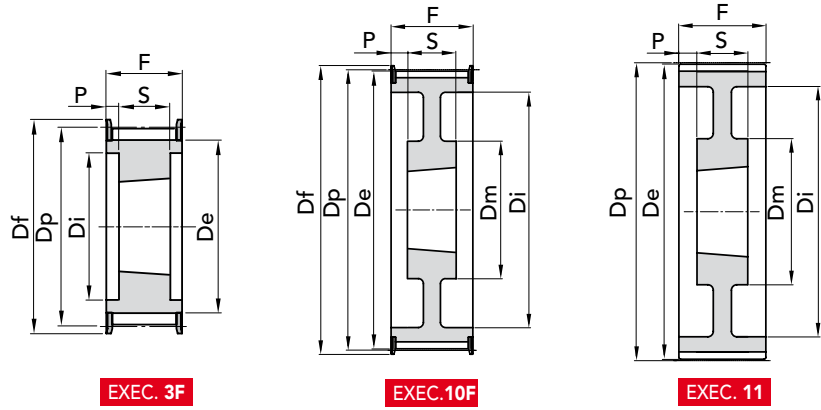

EXEC. 3F

EXEC. 10F

EXEC. 11

TYPE	P. NUMBER	N. TEETH	EXEC.	BUSH.	BORE MAX	Dp	De	Df FLANGE	Dm HUB	Ø Di	F	S	P	N. FLANGE	WEIGHT kg.
TL 28-14M- 55	41655028	28	3F	2012	50	124,78	122,12	128	-	94	70	32	19	153	2,20
TL 29-14M- 55	41655029	29	3F	2012	50	129,23	126,57	138	-	100	70	32,0	19	154	2,50
TL 30-14M- 55	41655030	30	3F	2517	60	133,69	130,99	138	-	100	70	45	12,5	154	2,70
TL 32-14M- 55	41655032	32	3F	2517	60	142,60	139,88	154	-	108	70	45	12,5	160	3,60
TL 34-14M- 55	41655034	34	3F	2517	60	151,52	148,79	160	-	110	70	45	12,5	166	4,50
TL 36-14M- 55	41655036	36	3F	2517	60	160,43	157,68	168	-	120	70	45	12,5	168	5,20
TL 38-14M- 55	41655038	38	3F	2517	60	169,34	166,60	183	-	130	70	45	12,5	172	6,20
TL 40-14M- 55	41655040	40	3F	2517	60	178,25	175,49	188	-	138	70	45	12,5	162	7,00
TL 42-14M- 55	41655042	42	3F	3020	75	187,16	184,37	200	-	147	70	51	9,5	SP	8,00
TL 44-14M- 55	41655044	44	3F	3020	75	196,08	193,28	211	-	155	70	51	9,5	175	8,60
TL 48-14M- 55	41655048	48	3F	3020	75	213,90	211,11	226	-	170	70	51	9,5	180	11,00
TL 56-14M- 55	41655056	56	3F	3020	75	249,55	246,76	256	-	208	70	51	9,5	182	13,50
TL 64-14M- 55	41655064	64	10F	3020	75	285,21	282,41	296	170	240	70	51	9,5	184	14,50
TL 72-14M- 55	41655072	72	11	3020	75	320,86	318,06	-	170	280	70	51	9,5	-	16,30
TL 80-14M- 55	41655080	80	12	3020	75	356,51	353,71	-	170	315	70	51	9,5	-	17,50
TL 90-14M- 55	41655090	90	12	3020	75	401,07	398,28	-	170	360	70	51	9,5	-	20,00
TL 112-14M- 55	41655112	112	12	3020	75	499,11	496,32	-	170	457	70	51	9,5	-	28,20
TL 144-14M- 55	41655144	144	12	3020	75	641,71	638,92	-	170	600	70	51	9,5	-	36,00
TL 168-14M- 55	41655168	168	12	3020	75	748,66	745,87	-	170	706	70	51	9,5	-	48,50
TL 192-14M- 55	41655192	192	12	3020	75	855,62	852,82	-	170	813	70	51	9,5	-	52,00
TL 216-14M- 55	41655216	216	13	3535	90	962,57	959,76	-	190	920	70	89	9,5	-	59,00
TL 264-14M- 55	41655264	264	13	4040	100	1176,47	1173,66	-	230	1133	70	102	16	-	97,50

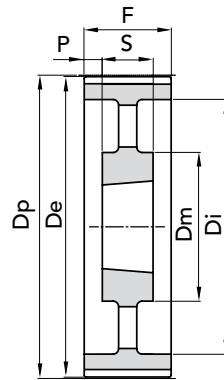

EXEC. 12

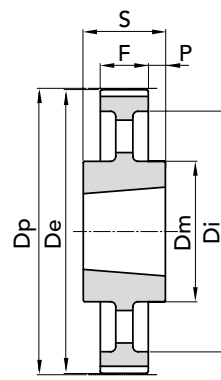

EXEC. 13

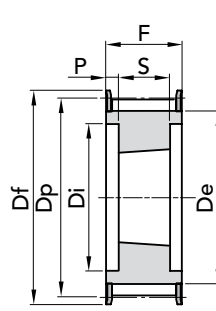

The images do not identify the products.

 TYPE **14M 85**

EXEC. 3F

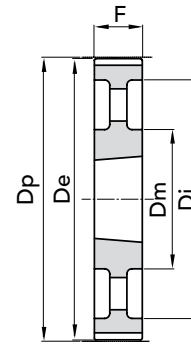

EXEC. 9

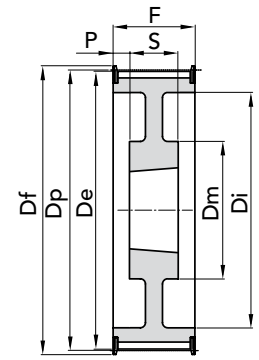

EXEC. 10F

TYPE	P. NUMBER	N. TEETH	EXEC.	BUSH.	BORE MAX	Dp	De	Df FLANGE	Dm HUB	Ø Di	F	S	P	N. FLANGE	WEIGHT kg.
TL 28-14M- 85	41685028	28	3F	2517	60	124,78	122,12	128	-	98	102	45	28,5	153	2,70
TL 29-14M- 85	41685029	29	3F	2517	60	129,23	126,57	138	-	100	102	45	28,5	154	3,50
TL 30-14M- 85	41685030	30	3F	2517	60	133,69	130,99	138	-	100	102	45	28,5	154	3,80
TL 32-14M- 85	41685032	32	3F	2517	60	142,60	139,88	154	-	108	102	45	28,5	160	4,70
TL 34-14M- 85	41685034	34	3F	2517	60	151,52	148,79	160	-	110	102	45	28,5	166	6,00
TL 36-14M- 85	41685036	36	3F	3020	75	160,43	157,68	168	-	125	102	51	25,5	168	5,70
TL 38-14M- 85	41685038	38	3F	3020	75	169,34	166,60	183	-	130	102	51	25,5	172	6,80
TL 40-14M- 85	41685040	40	3F	3020	75	178,25	175,49	188	-	138	102	51	25,5	162	8,00
TL 44-14M- 85	41685044	44	3F	3020	75	196,08	193,28	211	-	153	102	51	25,5	175	11,70
TL 48-14M- 85	41685048	48	3F	3020	75	213,90	211,11	226	-	171	102	51	25,5	180	15,00
TL 56-14M- 85	41685056	56	3F	3525	90	249,55	246,76	256	-	210	102	65	18,5	182	19,00
TL 64-14M- 85	41685064	64	10F	3525	90	285,21	282,41	296	190	240	102	65	18,5	184	24,00
TL 72-14M- 85	41685072	72	11	3525	90	320,86	318,06	-	190	280	102	65	18,5	-	25,00
TL 80-14M- 85	41685080	80	12	3525	90	356,51	353,71	-	190	315	102	65	18,5	-	26,00
TL 90-14M- 85	41685090	90	12	3525	90	401,70	398,28	-	190	360	102	65	18,5	-	28,00
TL 112-14M- 85	41685112	112	12	3525	90	499,11	496,32	-	190	457	102	65	18,5	-	36,00
TL 144-14M- 85	41685144	144	12	3525	90	641,71	638,92	-	190	600	102	65	18,5	-	48,00
TL 168-14M- 85	41685168	168	12	3525	90	748,66	745,87	-	190	706	102	65	18,5	-	60,00
TL 192-14M- 85	41685192	192	9	4040	100	855,62	852,82	-	230	813	102	102	-	-	85,00
TL 216-14M- 85	41685216	216	9	4040	100	962,57	959,76	-	230	920	102	102	-	-	101,50
TL 264-14M- 85	41685264	264	9	4040	100	1176,47	1173,66	-	230	1133	102	102	-	-	138,00

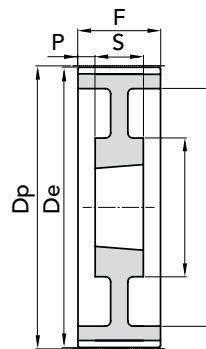

EXEC. 11

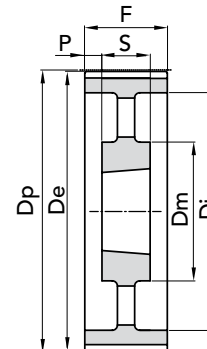

EXEC. 12

MATERIAL **STEEL**MATERIAL **CAST-IRON**
 CAD drawings available on our site
www.chiaravalli.com

 Quantity, availability and prices
 on B2B Chiaravalli



TYPE 14M 115

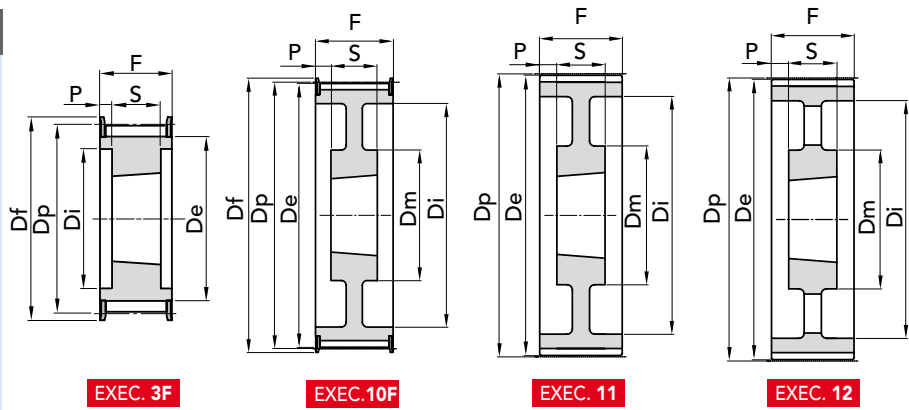

HTD® TAPER LOCK® TIMING PULLEYS "PHOSPHATED" 14M 115

TYPE	P. NUMBER	N. TEETH	EXEC.	BUSH.	BORE MAX	Dp	De	Df FLANGE	Dm HUB	Ø Di	F	S	P	N. FLANGE	WEIGHT kg.
TL 28-14M-115	41690028	28	3F	2517	60	124,78	122,12	128	-	98	133	45	44	153	3,80
TL 29-14M-115	on demand	29	3F	2517	60	129,23	126,57	138	-	100	133	45	44	154	-
TL 30-14M-115	41690030	30	3F	2517	60	133,69	130,99	138	-	100	133	45	44	154	5,00
TL 32-14M-115	41690032	32	3F	2517	60	142,60	139,88	154	-	108	133	45	44	160	6,80
TL 34-14M-115	41690034	34	3F	2517	60	151,52	148,79	160	-	110	133	45	44	166	6,90
TL 36-14M-115	41690036	36	3F	3020	75	160,43	157,68	168	-	125	133	51	41	168	7,00
TL 38-14M-115	41690038	38	3F	3020	75	169,34	166,60	183	-	130	133	51	41	172	8,50
TL 40-14M-115	41690040	40	3F	3020	75	178,25	175,49	188	-	138	133	51	41	162	9,10
TL 44-14M-115	41690044	44	3F	3030	75	196,08	193,28	211	-	155	133	76	28,5	175	13,00
TL 48-14M-115	41690048	48	3F	3030	75	213,90	211,11	226	-	170	133	76	28,5	180	16,00
TL 56-14M-115	41690056	56	3F	3535	90	249,55	246,76	256	-	210	133	89	22	182	24,00
TL 64-14M-115	41690064	64	10F	3535	90	285,21	282,41	296	190	240	133	89	22	184	32,00
TL 72-14M-115	41690072	72	11	3535	90	320,86	318,06	-	190	280	133	89	22	-	31,00
TL 80-14M-115	41690080	80	12	3535	90	356,51	353,71	-	190	315	133	89	22	-	32,00
TL 90-14M-115	41690090	90	12	3535	90	401,07	398,28	-	190	360	133	89	22	-	37,00
TL 112-14M-115	41690112	112	12	3535	90	499,11	496,32	-	190	457	133	89	22	-	45,00
TL 144-14M-115	41690144	144	12	4040	100	641,71	638,92	-	230	600	133	102	15,5	-	63,00
TL 168-14M-115	41690168	168	12	4040	100	748,66	745,87	-	230	706	133	102	15,5	-	77,50
TL 192-14M-115	41690192	192	12	4040	100	855,62	852,82	-	230	813	133	102	15,5	-	95,00
TL 216-14M-115	on demand	216	12	4040	100	962,57	959,76	-	230	920	133	102	15,5	-	-
TL 264-14M-115	41690264	264	12	5050	125	1176,47	1173,66	-	270	1133	133	127	3	-	120,0

MATERIAL **STEEL**

MATERIAL **CAST-IRON**

CAD drawings available on our site
www.chiaravalli.com

Quantity, availability and prices
 on B2B Chiaravalli

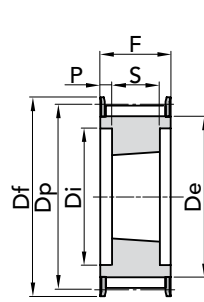

The images do not identify the products.

 TYPE **14M 170**

EXEC. 3F

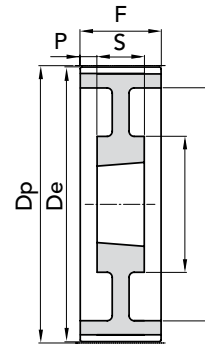

EXEC. 11

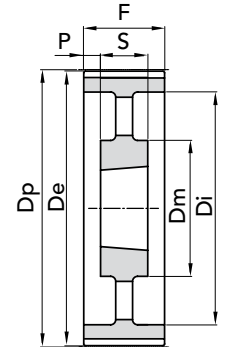

EXEC. 12

TYPE	P. NUMBER	N. TEETH	EXEC.	BUSH.	BORE MAX	Dp	De	Df FLANGE	Dm HUB	Ø Di	F	S	P	N. FLANGE	WEIGHT kg.
TL 38-14M-170	41692038	38	3F	3030	75	169,34	166,60	183	-	130	187	76	55,5	172	11,70
TL 40-14M-170	41692040	40	3F	3030	75	178,25	175,49	188	-	138	187	76	55,5	162	13,00
TL 44-14M-170	41692044	44	3F	3535	90	196,08	193,28	211	-	155	187	89	49	175	15,00
TL 48-14M-170	41692048	48	3F	3535	90	213,90	211,11	226	-	175	187	89	49	180	19,00
TL 56-14M-170	41692056	56	3F	3535	90	249,55	246,76	256	-	210	187	89	49	182	28,50
TL 64-14M-170	on demand	64	3F	4040	100	285,21	282,41	296	-	240	187	102	42,5	184	
TL 72-14M-170	on demand	72	11	4040	100	320,86	318,06	-	230	280	187	102	42,5	-	-
TL 80-14M-170	41692080	80	11	4040	100	356,51	353,71	-	230	315	187	102	42,5	-	48,00
TL 90-14M-170	41692090	90	12	4040	100	401,07	398,28	-	230	360	187	102	42,5	-	52,50
TL 112-14M-170	41692112	112	12	5050	125	499,11	496,32	-	265	457	187	127	30	-	74,50
TL 144-14M-170	41692144	144	12	5050	125	641,71	638,92	-	265	600	187	127	30	-	91,00
TL 168-14M-170	41692168	168	12	5050	125	748,66	745,87	-	265	706	187	127	30	-	116,00
TL 192-14M-170	on demand	192	12	5050	125	855,62	852,82	-	265	813	187	127	30	-	-
TL 216-14M-170	on demand	216	12	5050	125	962,57	959,76	-	265	920	187	127	30	-	-

 MATERIAL **STEEL**

 MATERIAL **CAST-IRON**

 CAD drawings available on our site
www.chiaravalli.com

 Quantity, availability and prices
 on B2B Chiaravalli

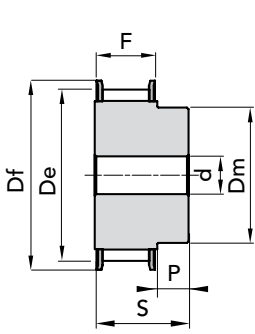
EXEC. 1F

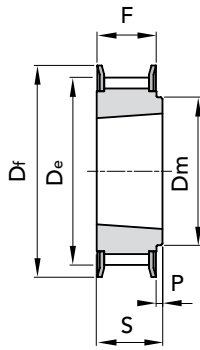

EXEC. 2F

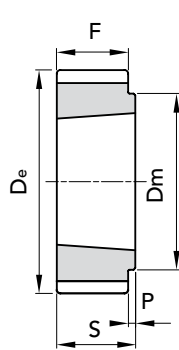

EXEC. 3

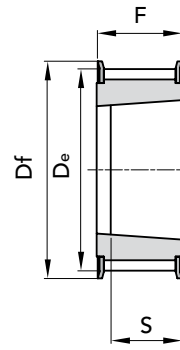

EXEC. 4F

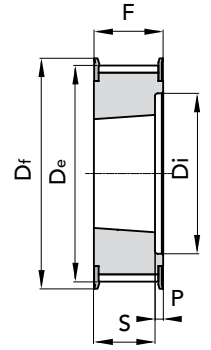

EXEC. 5F

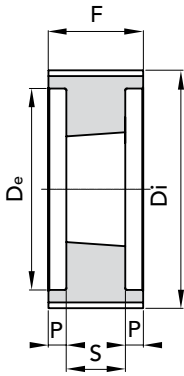

EXEC. 6

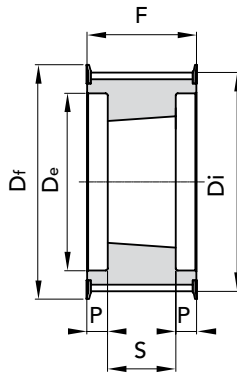

EXEC. 7F

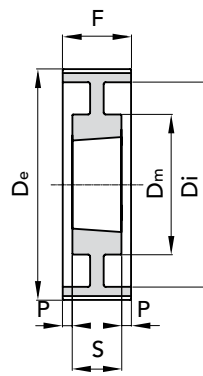

EXEC. 8

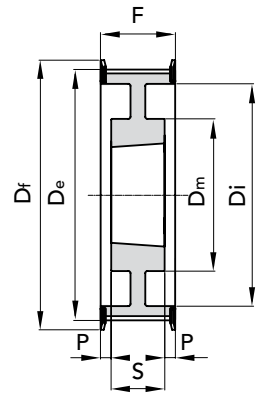

EXEC. 9F

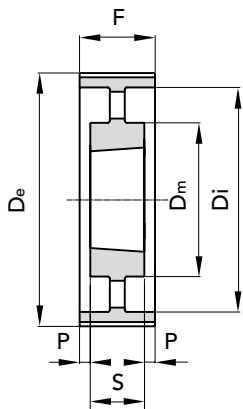

EXEC. 10

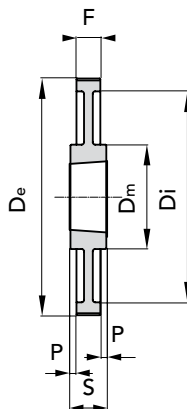

EXEC. 11

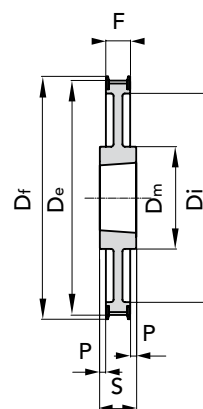

EXEC. 12F

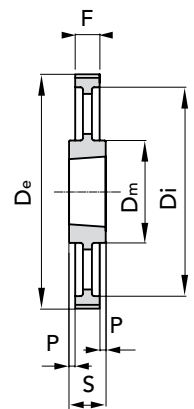

EXEC. 13



TAPER LOCK® PHOSPHATED

TYPE 8M-12

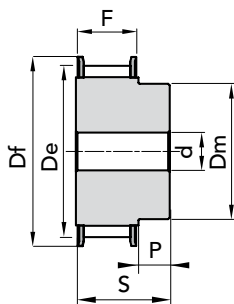

EXEC. 1F

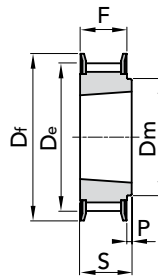

EXEC. 2F

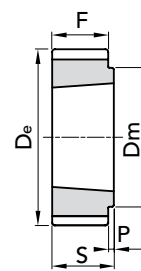

EXEC. 3

TYPE	P. NUMBER	N. TEETH	EXEC.	BUSH.	BORE MAX	Dp	De	Df FLANGE	Dm HUB	F	S	P	N. FLANGE	WEIGHT kg.
8M-22S- 12	48612022	22	1F	-	28	56,02	54,42	60	43	20	30	10	53	0,43
TL 8M-25S- 12	48612025	25	2F	1108	28	63,66	62,06	70	49	20	22	2	61	0,25
TL 8M-28S- 12	48612028	28	2F	1108	28	71,3	69,7	75	56	20	22	2	79	0,37
TL 8M-30S- 12	48612030	30	2F	1210	32	76,39	74,79	82,5	60	20	25	5	82	0,41
TL 8M-32S- 12	48612032	32	2F	1610	42	81,49	79,89	87	66	20	25	5	76	0,43
TL 8M-34S- 12	48612034	34	2F	1610	42	86,58	84,98	91	69	20	25	5	66	0,45
TL 8M-36S- 12	48612036	36	2F	1610	42	91,67	90,07	97	76	20	25	5	68	0,59
TL 8M-38S- 12	48612038	38	2F	1610	42	96,77	95,17	102	78	20	25	5	70	0,70
TL 8M-40S- 12	48612040	40	2F	1610	42	101,86	100,26	106	85	20	25	5	77	0,82
TL 8M-45S- 12	48612045	45	2F	2012	50	114,59	112,99	120	92	20	32	12	75	1,10
TL 8M-48S- 12	48612048	48	2F	2012	50	122,23	120,63	128	103	20	32	12	78	1,42
TL 8M-50S- 12	48612050	50	2F	2012	50	127,32	125,72	135	104	20	32	12	80	1,60
TL 8M-56S- 12	48612056	56	2F	2012	50	142,6	141	150	104	20	32	12	85	2,10
TL 8M-60S- 12	48612060	60	2F	2012	50	152,79	151,19	158	111	20	32	12	86	2,40
TL 8M-64S- 12	48612064	64	2F	2012	50	162,97	161,37	168	111	20	32	12	90	2,70
TL 8M-75S- 12	48612075	75	3	2012	50	190,99	189,39	-	111	20	32	12	-	3,70
TL 8M-80S- 12	48612080	80	3	2012	50	203,72	202,12	-	111	20	32	12	-	4,40
TL 8M-90S- 12	48612090	90	3	2012	50	229,18	227,58	-	111	20	32	12	-	5,50

MATERIAL **STEEL**
C 45

CAD drawings available on our site
www.chiaravalli.com

Quantity, availability and prices
on B2B Chiaravalli



The images do not identify the products.

POLY CHAIN® GT® TIMING PULLEYS TYPE 8M-12

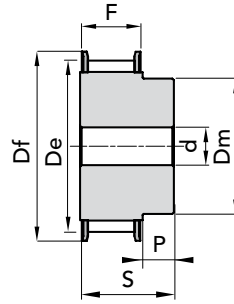
TAPER LOCK® PHOSPHATED
TYPE 8M-21

EXEC. 1F

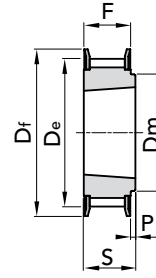

EXEC. 2F

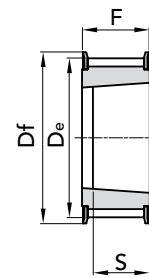

EXEC. 4F

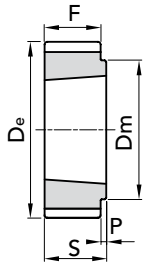

EXEC. 3

TYPE	P. NUMBER	N. TEETH	EXEC.	BUSH.	BORE MAX	Dp	De	Df FLANGE	Dm HUB	Ø Di	F	S	P	N. FLANGE	WEIGHT kg.
8M-22S- 21	48621022	22	1F	-	28	56,02	54,42	60	43	-	30	40	10	53	0,56
TL 8M-25S- 21	48621025	25	4F	1108	28	63,66	62,06	70	-	-	30	22	-	61	0,36
TL 8M-28S- 21	48621028	28	4F	1210	32	71,3	69,7	75	-	-	30	25	-	79	0,41
TL 8M-30S- 21	48621030	30	4F	1210	32	76,39	74,79	82,5	-	-	30	25	-	82	0,56
TL 8M-32S- 21	48621032	32	4F	1610	42	81,49	79,89	87	-	-	30	25	-	76	0,52
TL 8M-34S- 21	48621034	34	4F	1610	42	86,58	84,98	91	-	-	30	25	-	66	0,61
TL 8M-36S- 21	48621036	36	4F	1610	42	91,67	90,07	97	-	-	30	25	-	68	0,70
TL 8M-38S- 21	48621038	38	4F	1610	42	96,77	95,17	102	-	-	30	25	-	70	0,92
TL 8M-40S- 21	48621040	40	4F	1610	42	101,86	100,26	106	-	-	30	25	-	77	1,06
TL 8M-45S- 21	48621045	45	2F	2012	50	114,59	112,99	120	92	-	30	32	2	75	1,30
TL 8M-48S- 21	48621048	48	2F	2012	50	122,23	120,63	128	103	-	30	32	2	78	1,60
TL 8M-50S- 21	48621050	50	2F	2012	50	127,32	125,72	135	104	-	30	32	2	80	1,83
TL 8M-56S- 21	48621056	56	2F	2012	50	142,6	141	150	104	-	30	32	2	85	2,40
TL 8M-60S- 21	48621060	60	2F	2517	60	152,79	151,19	158	124	-	30	45	15	86	3,20
TL 8M-64S- 21	48621064	64	2F	2517	60	162,97	161,37	168	124	-	30	45	15	90	3,80
TL 8M-75S- 21	48621075	75	3	2517	60	190,99	189,39	-	124	-	30	45	15	-	6,20
TL 8M-80S- 21	48621080	80	3	2517	60	203,72	202,12	-	124	-	30	45	15	-	6,00
TL 8M-90S- 21	48621090	90	11	2517	60	229,18	227,58	-	124	198	30	45	7,5	-	5,40
TL 8M-112S- 21	48621112	112	11	2517	60	285,21	283,61	-	124	253	30	45	7,5	-	7,40
TL 8M-140S- 21	48621140	140	13	3020	75	356,51	354,91	-	150	324	30	51	10,5	-	9,00

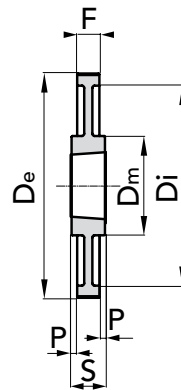

EXEC. 11

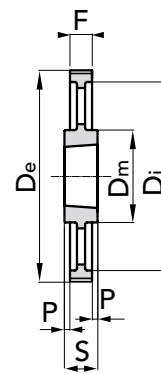

EXEC. 13

MATERIAL **STEEL**
C 45

MATERIAL **CAST-IRON**

CAD drawings available on our site
www.chiaravalli.com

Quantity, availability and prices
on B2B Chiaravalli





TAPER LOCK® PHOSPHATED

TYPE 8M-36

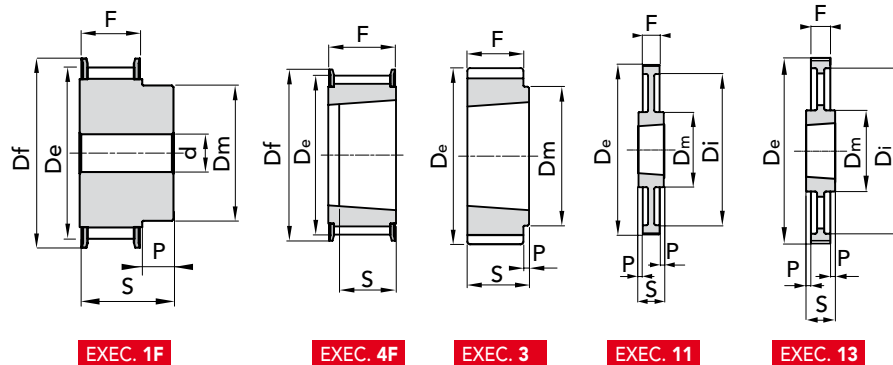

POLY CHAIN® GT® TIMING PULLEYS TYPE 8M-36

TYPE	P. NUMBER	N. TEETH	EXEC.	BUSH.	BORE MAX	Dp	De	Df FLANGE	Dm HUB	Ø Di	F	S	P	N. FLANGE	WEIGHT kg.
8M-25S- 36	48636025	25	1F	-	32	63,66	62,06	70	49	-	45	55	10	61	1,40
TL 8M-28S- 36	48636028	28	4F	1210	32	71,3	69,7	75	-	-	45	25	-	79	0,64
TL 8M-30S- 36	48636030	30	4F	1610	42	76,39	74,79	82,5	-	-	45	25	-	82	0,59
TL 8M-32S- 36	48636032	32	4F	1610	42	81,49	79,89	87	-	-	45	25	-	76	0,79
TL 8M-34S- 36	48636034	34	4F	1610	42	86,58	84,98	91	-	-	45	25	-	66	0,63
TL 8M-36S- 36	48636036	36	4F	1610	42	91,67	90,07	97	-	-	45	25	-	68	1,15
TL 8M-38S- 36	48636038	38	4F	1610	42	96,77	95,17	102	-	-	45	25	-	70	1,39
TL 8M-40S- 36	48636040	40	4F	2012	50	101,86	100,26	106	-	-	45	32	-	77	1,34
TL 8M-45S- 36	48636045	45	4F	2012	50	114,59	112,99	120	-	-	45	32	-	75	1,87
TL 8M-48S- 36	48636048	48	4F	2012	50	122,23	120,63	128	-	-	45	32	-	78	2,20
TL 8M-50S- 36	48636050	50	4F	2012	50	127,32	125,72	135	-	-	45	32	-	80	2,70
TL 8M-56S- 36	48636056	56	4F	2517	60	142,6	141	150	-	-	45	45	-	85	3,00
TL 8M-60S- 36	48636060	60	4F	2517	60	152,79	151,19	158	-	-	45	45	-	86	3,80
TL 8M-64S- 36	48636064	64	4F	2517	60	162,97	161,37	168	-	-	45	45	-	90	4,50
TL 8M-75S- 36	48636075	75	3	3020	75	190,99	189,39	-	150	-	45	51	6	-	6,20
TL 8M-80S- 36	48636080	80	3	3020	75	203,72	202,12	-	150	-	45	51	6	-	7,40
TL 8M-90S- 36	48636090	90	11	3020	75	229,18	227,58	-	150	197	45	51	3	-	7,20
TL 8M-112S- 36	48636112	112	11	3020	75	285,21	283,61	-	150	253	45	51	3	-	10,40
TL 8M-140S- 36	48636140	140	13	3020	75	356,51	354,91	-	150	324	45	51	3	-	12,70
TL 8M-168S- 36	48636168	168	13	3525	100	427,81	426,21	-	198	396	45	65	10	-	21,50
TL 8M-192S- 36	48636192	192	13	3525	100	488,92	487,32	-	198	457	45	65	10	-	27,00

MATERIAL **STEEL**
C 45

MATERIAL **CAST-IRON**

CAD drawings available on our site
www.chiaravalli.com

Quantity, availability and prices
on B2B Chiaravalli

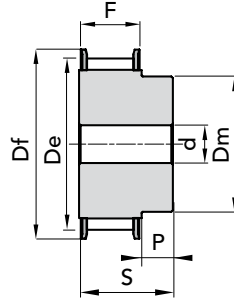

The images do not identify the products.

TAPER LOCK® PHOSPHATED
TYPE 8M-62

EXEC. 1F

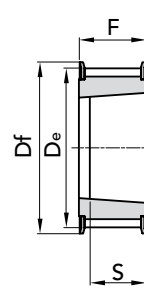

EXEC. 4F

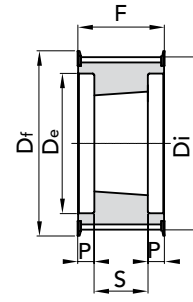

EXEC. 7F

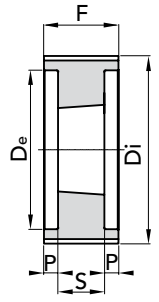

EXEC. 6

TYPE	P. NUMBER	N. TEETH	EXEC.	BUSH.	BORE MAX	Dp	De	Df FLANGE	Dm HUB	Ø Di	F	S	P	N. FLANGE	WEIGHT kg.
8M-30S- 62	48662030	30	1F	-	42	76,39	74,79	82,5	63	-	72	84	12	82	2,40
8M-32S- 62	48662032	32	1F	-	50	81,49	79,89	87	68	-	72	84	12	76	2,80
8M-34S- 62	48662034	34	1F	-	55	86,58	84,98	91	69	-	72	84	12	66	3,00
8M-36S- 63	48662036	36	1F	-	60	91,67	90,07	97	76	-	72	84	12	68	3,40
8M-38S- 62	48662038	38	1F	-	60	96,77	95,17	102	78	-	72	84	12	70	3,80
TL 8M-40S- 62	48662040	40	4F	2012	50	101,86	100,26	106	-	-	72	32	-	77	2,06
TL 8M-45S- 62	48662045	45	4F	2012	50	114,59	112,99	120	-	-	72	32	-	75	3,00
TL 8M-48S- 62	48662048	48	4F	2517	60	122,23	120,63	128	-	-	72	45	-	78	2,90
TL 8M-50S- 62	48662050	50	4F	2517	60	127,32	125,72	135	-	-	72	45	-	80	3,25
TL 8M-56S- 62	48662056	56	7F	2517	60	142,6	141	150	-	111	72	45	13,5	85	3,90
TL 8M-60S- 62	48662060	60	7F	2517	60	152,79	151,19	158	-	121	72	45	13,5	86	4,70
TL 8M-64S- 62	48662064	64	7F	2517	60	162,97	161,37	168	-	131	72	45	13,5	90	5,60
TL 8M-75S- 62	48662075	75	6	3020	75	190,99	189,39	-	-	159	72	51	10,5	-	7,50
TL 8M-80S- 62	48662080	80	6	3020	75	203,72	202,12	-	-	172	72	51	10,5	-	9,20
TL 8M-90S- 62	48662090	90	6	3020	75	229,18	227,58	-	-	197	72	51	10,5	-	7,70
TL 8M-112S- 62	48662112	112	8	3020	75	285,21	283,61	-	198	253	72	51	10,5	-	12,10
TL 8M-140S- 62	48662140	140	10	3525	100	356,51	354,91	-	150	324	72	65	3,5	-	22,70
TL 8M-168S- 62	48662168	168	10	3525	100	427,81	426,21	-	198	396	72	65	3,5	-	26,80
TL 8M-192S- 62	48662192	192	10	3525	100	488,92	487,32	-	198	457	72	65	3,5	-	34,20

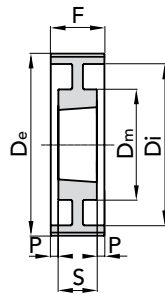

EXEC. 8

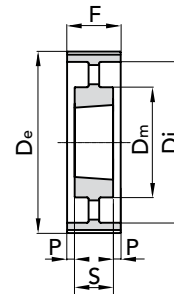

EXEC. 10

 MATERIAL **STEEL**
C 45

 MATERIAL **CAST-IRON**

 CAD drawings available on our site
www.chiaravalli.com

 Quantity, availability and prices
 on B2B Chiaravalli



TAPER LOCK® PHOSPHATED

TYPE 14M-20

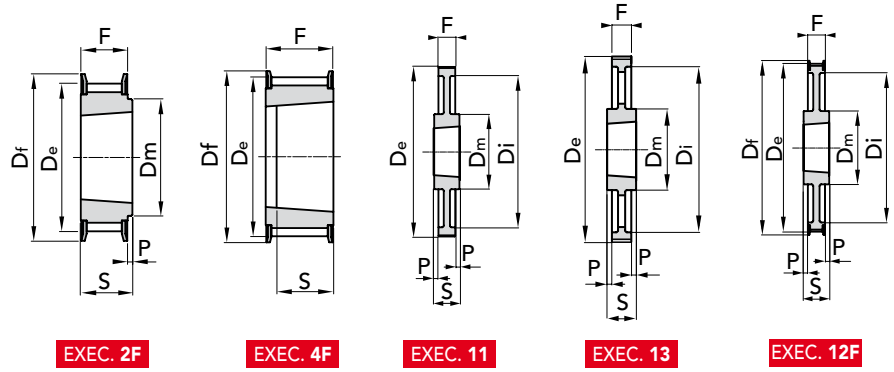

TYPE	P. NUMBER	N. TEETH	EXEC.	BUSH.	BORE MAX	Dp	De	Df FLANGE	Dm HUB	Ø Di	F	S	P	N. FLANGE	WEIGHT kg.
TL 14M-28S-20	48820028	28	4F	2012	50	124,78	121,98	128	-	-	33	32	1	153	1,66
TL 14M-30S-20	48820030	30	4F	2012	50	133,69	130,89	138	-	-	33	32	1	154	2,20
TL 14M-32S-20	48820032	32	4F	2012	50	142,6	139,8	154	-	-	33	32	1	160	3,20
TL 14M-34S-20	48820034	34	2F	2517	60	151,52	148,72	160	117	-	33	45	-	171	3,00
TL 14M-36S-20	48820036	36	2F	2517	60	160,43	157,63	168	117	-	33	45	-	168	3,60
TL 14M-38S-20	48820038	38	2F	2517	60	169,34	166,54	183	117	-	33	45	-	172	4,00
TL 14M-40S-20	48820040	40	2F	2517	60	178,25	175,45	188	117	-	33	45	-	174	4,70
TL 14M-44S-20	48820044	44	2F	3020	75	196,08	193,28	211	144	-	33	51	-	175	5,60
TL 14M-48S-20	48820048	48	2F	3020	75	213,9	211,11	226	144	-	33	51	-	180	6,80
TL 14M-50S-20	48820050	50	2F	3020	75	222,82	220,02	240	144	-	33	51	-	169	7,70
TL 14M-56S-20	48820056	56	12F	3020	75	249,55	246,76	256	144	207	33	51	9	182	7,70
TL 14M-60S-20	48820060	60	11	3020	75	267,38	264,58	-	159	224	33	51	9	-	8,50
TL 14M-64S-20	48820064	64	11	3020	75	285,21	282,41	-	159	242	33	51	9	-	10,20
TL 14M-72S-20	48820072	72	11	3020	75	320,86	318,06	-	159	278	33	51	9	-	11,50
TL 14M-80S-20	48820080	80	11	3020	75	356,51	353,71	-	159	314	33	51	9	-	13,50
TL 14M-90S-20	48820090	90	13	3020	75	401,07	398,27	-	159	360	33	51	9	-	14,20
TL 14M-112S-20	48820112	112	13	3020	75	499,11	496,31	-	159	456	33	51	9	-	18,10
TL 14M-140S-20	48820140	140	13	3020	75	623,89	621,09	-	159	581	33	51	9	-	22,90

MATERIAL **STEEL**
C 45

MATERIAL **CAST-IRON**

CAD drawings available on our site
www.chiaravalli.com

Quantity, availability and prices
on B2B Chiaravalli



The images do not identify the products.

POLY CHAIN® GT® TIMING PULLEYS TYPE 14M-20

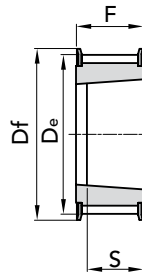

TAPER LOCK® PHOSPHATED

 TYPE **14M-37**

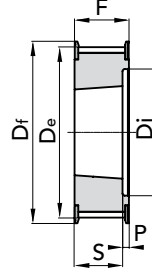
EXEC. 4F

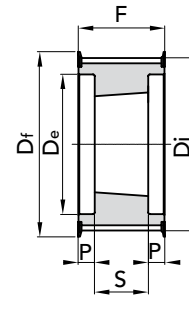

EXEC. 5F



EXEC. 7F

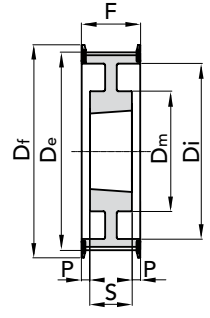

EXEC. 9F

TYPE	P. NUMBER	N. TEETH	EXEC.	BUSH.	BORE MAX	Dp	De	Df FLANGE	Dm HUB	Ø Di	F	S	P	N. FLANGE	WEIGHT kg.
TL 14M-28S-37	48837028	28	5F	2012	50	124,78	121,98	128	-	88	51	32	19	153	2,20
TL 14M-30S-37	48837030	30	7F	2517	60	133,69	130,89	138	-	98	51	45	3	154	2,50
TL 14M-32S-37	48837032	32	7F	2517	60	142,6	139,8	154	-	100	51	45	3	160	3,00
TL 14M-34S-37	48837034	34	7F	2517	60	151,52	148,72	160	-	109	51	45	3	171	3,80
TL 14M-36S-37	48837036	36	5F	2517	60	160,43	157,63	168	-	117	51	45	6	168	4,30
TL 14M-38S-37	48837038	38	5F	2517	60	169,34	166,54	183	-	126	51	45	6	172	5,10
TL 14M-40S-37	48837040	40	5F	2517	60	178,25	175,45	188	-	135	51	45	6	174	6,00
TL 14M-44S-37	48837044	44	4F	3020	75	196,08	193,82	211	-	-	51	51	-	175	7,00
TL 14M-48S-37	48837048	48	4F	3020	75	213,9	211,11	226	-	-	51	51	-	180	9,00
TL 14M-50S-37	48837050	50	4F	3020	75	222,82	220,02	240	-	-	51	51	-	169	10,00
TL 14M-56S-37	48837056	56	9F	3020	75	249,55	246,76	256	144	207	51	51	-	182	9,20
TL 14M-60S-37	48837060	60	8	3020	75	267,38	264,58	-	159	224	51	51	-	-	10,20
TL 14M-64S-37	48837064	64	8	3020	75	285,21	282,41	-	159	242	51	51	-	-	12,20
TL 14M-72S-37	48837072	72	8	3020	75	320,86	318,06	-	159	278	51	51	-	-	13,40
TL 14M-80S-37	48837080	80	8	3020	75	356,51	353,71	-	159	314	51	51	-	-	16,10
TL 14M-90S-37	48837090	90	10	3020	75	401,07	398,27	-	159	360	51	51	-	-	17,20
TL 14M-112S-37	48837112	112	10	3020	75	499,11	496,31	-	159	456	51	51	-	-	23,00
TL 14M-140S-37	48837140	140	13	3525	100	623,89	621,09	-	206	581	51	65	7	-	41,00
TL 14M-168S-37	48837168	168	13	3525	100	748,66	745,87	-	206	706	51	65	7	-	51,50
TL 14M-192S-37	48837192	192	13	4030	115	855,61	852,82	-	215	812	51	76	12,5	-	60,00

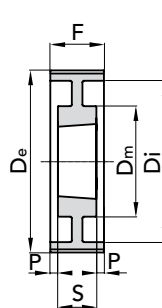

EXEC. 8

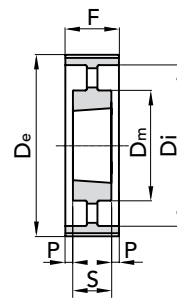

EXEC. 10

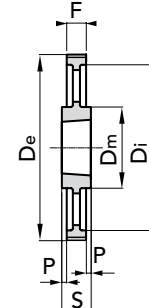

EXEC. 13

 MATERIAL **STEEL**
C 45

 MATERIAL **CAST-IRON**

 CAD drawings available on our site
www.chiaravalli.com

 Quantity, availability and prices
 on B2B Chiaravalli



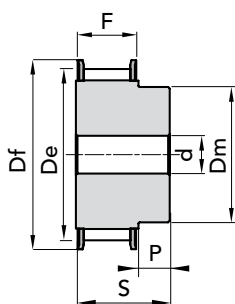

TAPER LOCK® PHOSPHATED

TYPE 14M-68

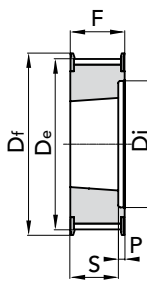

EXEC. 1F



EXEC. 5F

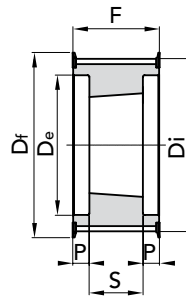

EXEC. 7F

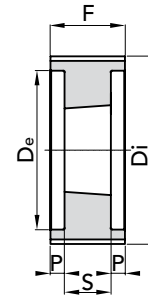

EXEC. 6

TYPE	P. NUMBER	N. TEETH	EXEC.	BUSH.	BORE MAX	Dp	De	Df FLANGE	Dm HUB	Ø Di	F	S	P	N. FLANGE	WEIGHT kg.
14M-34S- 68	48868034	34	1F	-	100	151,52	148,72	160	132	-	84	104	20	171	10,50
14M-36S- 68	48868036	36	1F	-	100	160,43	157,63	168	131	-	84	104	20	168	11,70
14M-38S- 68	48868038	38	1F	-	115	169,34	166,54	183	141	-	84	104	20	172	13,40
14M-40S- 68	48868040	40	1F	-	125	178,25	175,45	188	156	-	84	104	20	174	15,40
TL 14M-44S- 68	48868044	44	7F	3020	75	196,08	193,28	211	-	153	84	51	16,5	175	9,20
TL 14M-48S- 68	48868048	48	5F	3020	75	213,9	211,11	226	-	171	84	51	33	180	11,30
TL 14M-50S- 68	48868050	50	7F	3525	100	222,82	220,02	240	-	180	84	65	9,5	169	15,50
TL 14M-56S- 68	48868056	56	7F	3525	100	249,55	246,76	256	-	207	84	65	9,5	182	16,80
TL 14M-60S- 68	48868060	60	6	3525	100	267,38	264,58	-	-	224	84	65	9,5	-	20,40
TL 14M-64S- 68	48868064	64	6	3525	100	285,21	282,41	-	-	242	84	65	9,5	-	23,60
TL 14M-72S- 68	48868072	72	8	3525	100	320,86	318,06	-	178	278	84	65	9,5	-	20,30
TL 14M-80S- 68	48868080	80	10	3525	100	356,51	353,71	-	178	314	84	65	9,5	-	21,30
TL 14M-90S- 68	48868090	90	10	3525	100	401,07	398,27	-	178	360	84	65	9,5	-	24,40
TL 14M-112S- 68	48868112	112	10	3525	100	499,11	496,31	-	178	456	84	65	9,5	-	32,70
TL 14M-140S- 68	48868140	140	10	3525	100	623,89	621,09	-	206	581	84	65	9,5	-	55,00
TL 14M-168S- 68	48868168	168	10	3525	100	748,66	745,87	-	206	706	84	65	9,5	-	71,00
TL 14M-192S- 68	48868192	192	10	4030	115	855,61	852,82	-	215	812	84	76	4	-	80,50

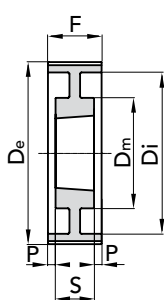

EXEC. 8

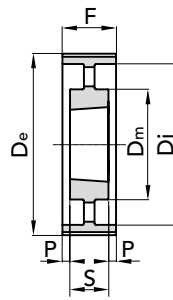

EXEC. 10

MATERIAL **STEEL**
C 45

MATERIAL **CAST-IRON**

CAD drawings available on our site
www.chiaravalli.com

Quantity, availability and prices
on B2B Chiaravalli



The images do not identify the products.

POLY CHAIN® GT® TIMING PULLEYS TYPE 14M-68

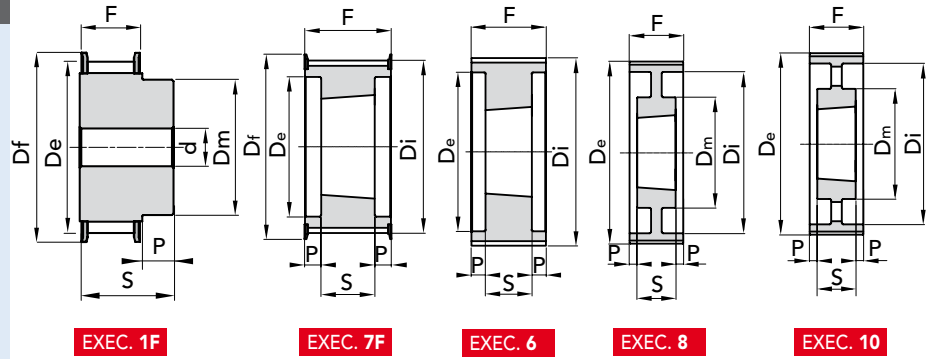
TAPER LOCK® PHOSPHATED
TYPE 14M-90

TYPE	P. NUMBER	N. TEETH	EXEC.	BUSH.	BORE MAX	Dp	De	Df FLANGE	Dm HUB	Ø Di	F	S	P	N. FLANGE	WEIGHT kg.
14M-36S-90	48890036	36	1F	-	110	160,43	157,63	168	131	-	106	136	30	168	14,50
14M-38S-90	48890038	38	1F	-	115	169,34	166,54	183	141	-	106	136	30	172	17,50
14M-40S-90	48890040	40	1F	-	125	178,25	175,45	188	156	-	106	136	30	174	19,10
14M-44S-90	48890044	44	1F	-	140	196,08	193,82	211	169	-	106	136	30	175	23,90
TL 14M-48S-90	48890048	48	7F	3525	100	213,9	211,11	226	-	171	106	66	20	180	12,70
TL 14M-50S-90	48890050	50	7F	3525	100	222,82	220,02	240	-	180	106	66	20	169	14,50
TL 14M-56S-90	48890056	56	7F	3525	100	249,55	246,76	256	-	207	106	66	20	182	19,00
TL 14M-60S-90	48890060	60	6	3525	100	267,38	264,58	-	-	224	106	66	20	-	22,50
TL 14M-64S-90	48890064	64	6	3525	100	285,21	282,41	-	-	242	106	66	20	-	24,00
TL 14M-72S-90	48890072	72	8	3525	100	320,86	318,06	-	178	278	106	66	20	-	22,60
TL 14M-80S-90	48890080	80	8	4030	115	356,51	353,71	-	215	314	106	76	15	-	27,00
TL 14M-90S-90	48890090	90	8	4030	115	401,07	398,27	-	215	360	106	76	15	-	34,10
TL 14M-112S-90	48890112	112	10	4535	125	499,11	496,31	-	215	456	106	90	8	-	46,00
TL 14M-140S-90	48890140	140	10	4535	125	623,89	621,09	-	215	581	106	90	8	-	61,00
TL 14M-168S-90	48890168	168	10	5040	130	748,66	745,87	-	267	706	106	102	2	-	90,00
TL 14M-192S-90	48890192	192	10	5040	130	855,61	852,82	-	267	812	106	102	2	-	108,50

 MATERIAL **STEEL**
C 45

 MATERIAL **CAST-IRON**

 CAD drawings available on our site
www.chiaravalli.com

 Quantity, availability and prices
 on B2B Chiaravalli



TAPER LOCK® PHOSPHATED

TYPE 14M-125

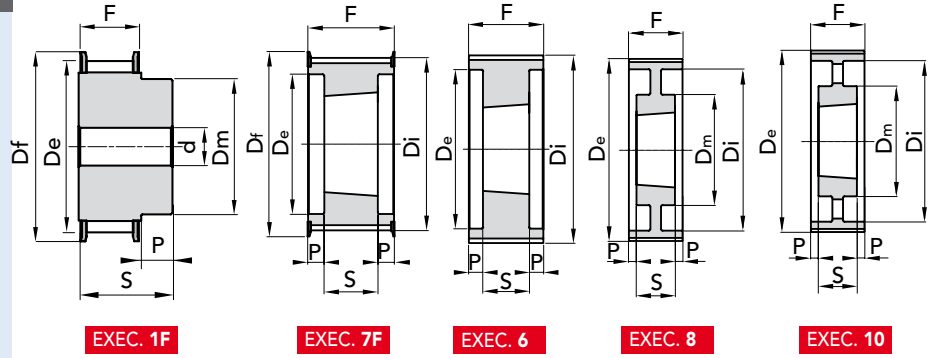

EXEC. 1F

EXEC. 7F

EXEC. 6

EXEC. 8

EXEC. 10

TYPE	P. NUMBER	N. TEETH	EXEC.	BUSH.	BORE MAX	Dp	De	Df FLANGE	Dm HUB	Ø Di	F	S	P	N. FLANGE	WEIGHT kg.
14M-38S-125	48892038	38	1F	-	115	169,34	166,54	183	141	-	141	161	20	172	20,30
14M-40S-125	48892040	40	1F	-	125	178,25	175,45	188	156	-	141	161	20	174	23,00
14M-44S-125	48892044	44	1F	-	140	196,08	193,82	211	169	-	141	161	20	175	28,80
14M-48S-125	48892048	48	1F	-	160	213,9	211,11	226	185	-	141	161	20	180	34,60
TL 14M-50S-125	48892050	50	7F	3525	100	222,82	220,02	240	-	180	141	65	38	169	16,80
TL 14M-56S-125	48892056	56	7F	3525	100	249,55	246,76	256	-	207	141	65	38	182	21,60
TL 14M-60S-125	48892060	60	6	4030	115	267,38	264,58	-	-	224	141	76	32,5	-	25,60
TL 14M-64S-125	48892064	64	6	4030	115	285,21	282,41	-	-	242	141	76	32,5	-	29,70
TL 14M-72S-125	48892072	72	8	4030	115	320,86	318,06	-	215	278	141	76	32,5	-	30,00
TL 14M-80S-125	48892080	80	8	4030	125	356,51	353,71	-	215	314	141	76	32,5	-	33,40
TL 14M-90S-125	48892090	90	8	4030	115	401,07	398,27	-	215	360	141	76	32,5	-	39,40
TL 14M-112S-125	48892112	112	10	4535	125	499,11	496,31	-	215	456	141	89	26	-	56,00
TL 14M-140S-125	48892140	140	10	4535	125	623,89	621,09	-	215	581	141	89	26	-	73,00
TL 14M-168S-125	48892168	168	10	5040	125	748,66	745,87	-	267	706	141	102	19,5	-	101,00
TL 14M-192S-125	48892192	192	10	5040	125	855,61	852,82	-	267	802	141	102	19,5	-	121,50

MATERIAL **CAST-IRON**

CAD drawings available on our site
www.chiaravalli.com

Quantity, availability and prices
on B2B Chiaravalli





"T" METRIC EXECUTIONS TIMING PULLEYS

DIMENSIONAL FEATURES

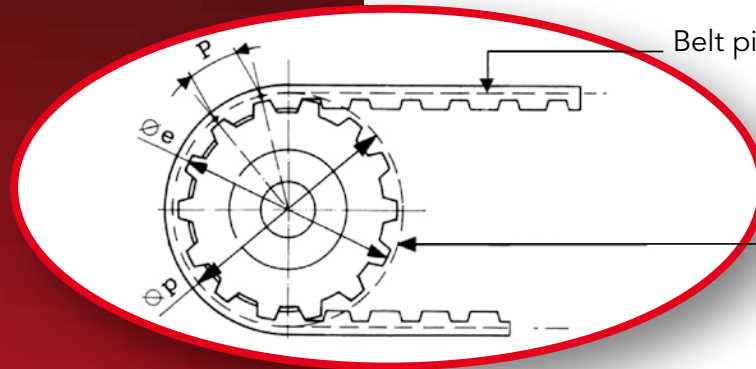

Belt pitch line circumference

Pulley pitch line circumference

SYMBOLS

- P = Pitch
- Z = N° of teeth
- Ø p = Pulley pitch line
- Ø e = External diameter
- Lp = Pulley width
- Lc = Belt width
- Lpc = Belt pitch line length

12 - T10 - 440

- 12 = Belt width in mm.
- T10 = Toothing pitch in mm.
- 440 = Pitch line length in mm.

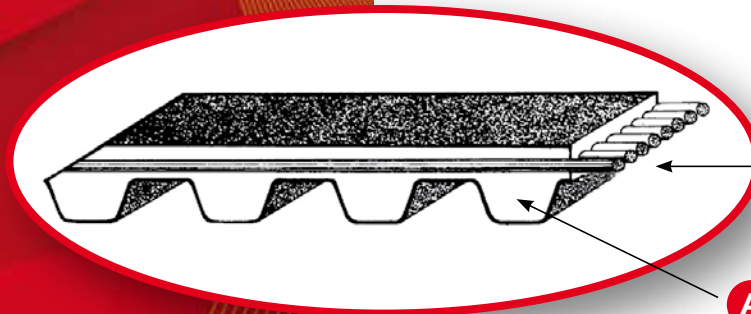

B
Steel reinforcing

A
Polyurethane belt body

STANDARD WIDTH FOR BELTS AND SHEARING TOLERANCES

belt pitch	belt width (mm)	width tolerance (mm)
T 2.5 (2.5 mm)	6	± 0.03
T 5 (5 mm)	10	± 0.5
	16	
	25	
T 10 (10 mm)	16	± 0.5
	25	
	32	
	50	

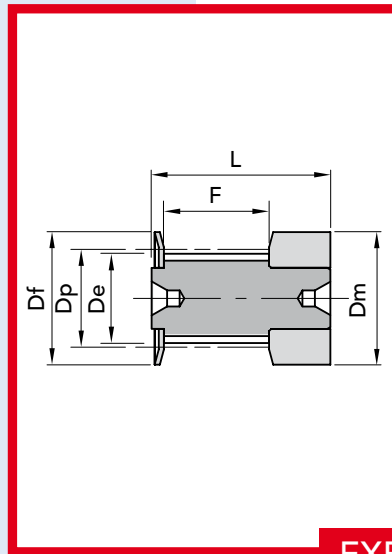

EXECUTION 0F

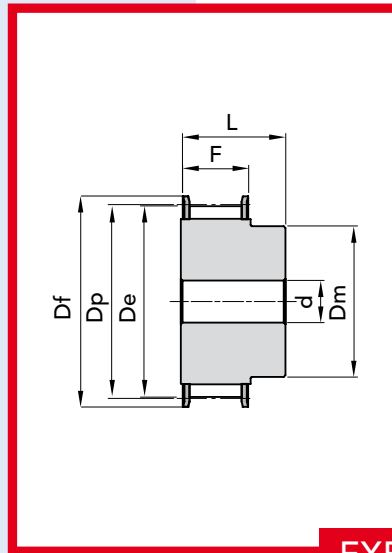

EXECUTION 1F

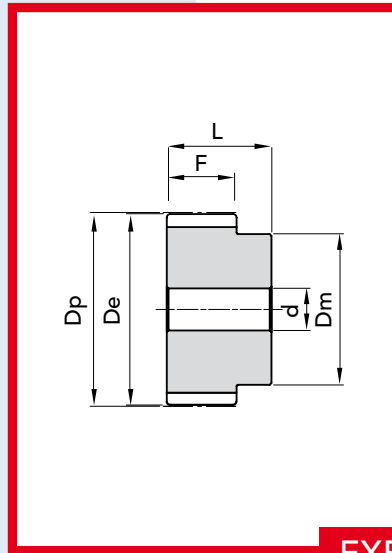

EXECUTION 2



TYPE T 2.5

PITCH 2.5 mm

for belt width 6mm

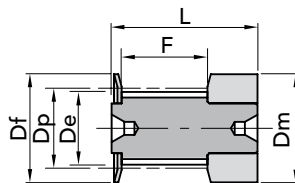

EXEC. 0F

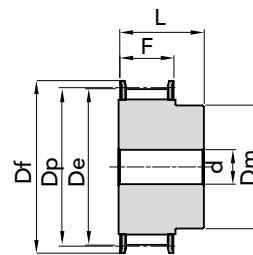

EXEC. 1F

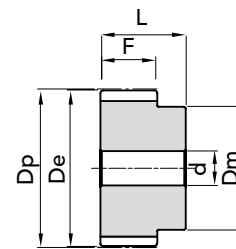

EXEC. 2

TYPE	P. NUMBER	EXEC.	N. TEETH	Dp	De	Df FLANGE	Dm HUB	F	L	d	N. FLANGE	WEIGHT Kg.
16 T2,5 12	45021612	0F	12	9,60	9,00	13,0	13	9	16	-	501	0,01
16 T2,5 14	45021614	0F	14	11,20	10,60	15,0	15	9	16	-	502	0,01
16 T2,5 15	45021615	0F	15	12,00	11,40	15,0	15	9	16	-	502	0,01
16 T2,5 16	45021616	0F	16	12,80	12,20	16,0	16	9	16	-	503	0,01
16 T2,5 18	45021618	1F	18	14,40	13,80	17,5	10	10	16	-	504	0,01
16 T2,5 19	45021619	1F	19	15,20	14,60	20,0	10	10	16	-	505	0,01
16 T2,5 20	45021620	1F	20	16,00	15,40	20,0	11	10	16	-	505	0,01
16 T2,5 22	45021622	1F	22	17,60	17,00	22,0	11	10	16	-	512	0,01
16 T2,5 24	45021624	1F	24	19,15	18,55	22,0	12	10	16	4	512	0,01
16 T2,5 25	45021625	1F	25	19,95	19,35	25,0	13	10	16	4	506	0,01
16 T2,5 26	45021626	1F	26	20,75	20,15	26,0	14	10	16	4	507	0,01
16 T2,5 28	45021628	1F	28	22,35	21,75	26,0	14	10	16	4	507	0,02
16 T2,5 30	45021630	1F	30	23,95	23,35	26,0	16	10	16	6	508	0,02
16 T2,5 32	45021632	1F	32	25,55	24,95	32,0	16	10	16	6	509	0,02
16 T2,5 36	45021636	1F	36	28,75	28,10	36,0	20	10	16	6	510	0,03
16 T2,5 40	45021640	1F	40	31,90	31,30	38,0	22	10	16	6	511	0,03
16 T2,5 44	45021644	2	44	35,10	34,50	-	24	10	16	6	-	0,04
16 T2,5 48	45021648	2	48	38,30	37,70	-	26	10	16	6	-	0,05
16 T2,5 60	45021660	2	60	47,85	47,25	-	34	10	16	8	-	0,07

MATERIAL ALUMINIUM

T20 pitch pulleys are manufactured on request.

CAD drawings available on our site
www.chiaravalli.com

Quantity, availability and prices
 on B2B Chiaravalli





"T" METRIC TIMING PULLEYS

TYPE T 5

PITCH 5 mm

for belt width 10mm

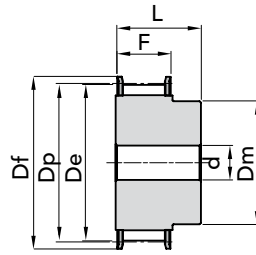

EXEC. 1F

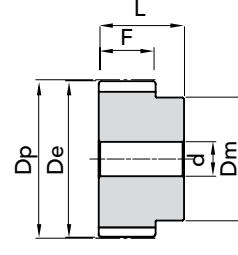

EXEC. 2

TYPE	P. NUMBER	EXEC.	N. TEETH	Dp	De	Df FLANGE	Dm HUB	F	L	d	N. FLANGE	WEIGHT Kg.
21 T5 10	45052110	1F	10	15,92	15,05	19,5	8	15	21	-	3	0,01
21 T5 12	45052112	1F	12	19,10	18,25	23,0	11	15	21	-	1	0,01
21 T5 14	45052114	1F	14	22,29	21,45	25,0	13	15	21	-	2	0,02
21 T5 15	45052115	1F	15	23,88	23,05	28,0	16	15	21	6	4	0,02
21 T5 16	45052116	1F	16	25,47	24,60	32,0	18	15	21	6	5	0,03
21 T5 18	45052118	1F	18	28,65	27,80	32,0	20	15	21	6	6	0,03
21 T5 19	45052119	1F	19	30,25	29,40	36,0	22	15	21	6	8	0,04
21 T5 20	45052120	1F	20	31,83	31,00	36,0	23	15	21	6	8	0,04
21 T5 22	45052122	1F	22	35,02	34,15	38,0	24	15	21	6	9	0,05
21 T5 24	45052124	1F	24	38,21	37,40	42,0	26	15	21	6	13	0,06
21 T5 25	45052125	1F	25	29,80	38,95	44,0	26	15	21	6	12	0,06
21 T5 26	45052126	1F	26	41,39	40,60	44,0	26	15	21	6	12	0,06
21 T5 27	45052127	1F	27	42,98	42,20	48,0	30	15	21	8	11	0,07
21 T5 28	45052128	1F	28	44,58	43,75	48,0	32	15	21	8	11	0,07
21 T5 30	45052130	1F	30	47,76	46,95	51,0	34	15	21	8	16	0,07
21 T5 32	45052132	1F	32	50,94	50,10	54,0	38	15	21	8	18	0,09
21 T5 36	45052136	1F	36	57,31	56,45	64,0	38	15	21	8	23	0,11
21 T5 40	45052140	1F	40	63,66	62,85	66,5	40	15	21	8	24	0,14
21 T5 42	45052142	1F	42	66,86	66,00	70,0	40	15	21	8	26	0,18
21 T5 44	45052144	2	44	70,05	69,20	-	45	15	21	8	-	0,18
21 T5 48	45052148	2	48	76,42	75,55	-	50	15	21	8	-	0,20
21 T5 60	45052160	2	60	95,52	94,65	-	65	15	21	8	-	0,31

"T" METRIC TIMING PULLEYS TYPE T 5 (PITCH 5mm)

MATERIAL ALUMINIUM

T20 pitch pulleys are manufactured on request.

CAD drawings available on our site www.chiaravalli.com

Quantity, availability and prices on B2B Chiaravalli



The images do not identify the products.



TYPE T 5

PITCH 5 mm

for belt width 16mm

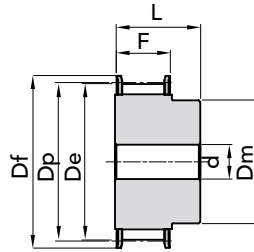

EXEC. 1F

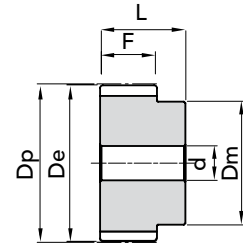

EXEC. 2

TYPE	P. NUMBER	EXEC.	N. TEETH	Dp	De	Df FLANGE	Dm HUB	F	L	d	N. FLANGE	WEIGHT kg.
27 T5 10	45052710	1F	10	15,92	15,05	19,5	8	21	27	-	3	0,02
27 T5 12	45052712	1F	12	19,10	18,25	23,0	11	21	27	-	1	0,02
27 T5 14	45052714	1F	14	22,29	21,45	25,0	13	21	27	-	2	0,03
27 T5 15	45052715	1F	15	23,88	23,05	28,0	16	21	27	6	4	0,03
27 T5 16	45052716	1F	16	25,47	24,60	32,0	18	21	27	6	5	0,04
27 T5 18	45052718	1F	18	28,65	27,80	32,0	20	21	27	6	6	0,04
27 T5 19	45052719	1F	19	30,25	29,40	36,0	22	21	27	6	8	0,05
27 T5 20	45052720	1F	20	31,83	31,00	36,0	23	21	27	6	8	0,06
27 T5 22	45052722	1F	22	35,02	34,15	38,0	24	21	27	6	9	0,06
27 T5 24	45052724	1F	24	38,21	37,40	42,0	26	21	27	6	13	0,08
27 T5 25	45052725	1F	25	39,80	38,95	44,0	26	21	27	6	12	0,08
27 T5 26	45052726	1F	26	41,39	40,60	44,0	26	21	27	6	12	0,09
27 T5 27	45052727	1F	27	42,98	42,20	48,0	30	21	27	8	11	0,09
27 T5 28	45052728	1F	28	44,58	43,75	48,0	32	21	27	8	11	0,09
27 T5 30	45052730	1F	30	47,76	46,95	51,0	34	21	27	8	16	0,10
27 T5 32	45052732	1F	32	50,94	50,10	54,0	38	21	27	8	18	0,12
27 T5 36	45052736	1F	36	57,31	56,45	64,0	38	21	27	8	23	0,16
27 T5 40	45052740	1F	40	63,66	62,85	66,5	40	21	27	8	24	0,19
27 T5 42	45052742	1F	42	66,86	66,00	70,0	40	21	27	8	26	0,20
27 T5 44	45052744	2	44	70,05	69,20	-	45	21	27	8	-	0,23
27 T5 48	45052748	2	48	76,42	75,55	-	50	21	27	8	-	0,28
27 T5 60	45052760	2	60	95,52	94,65	-	65	21	27	8	-	0,43

MATERIAL ALUMINIUM

T20 pitch pulleys are manufactured on request.

CAD drawings available on our site
www.chiaravalli.com

Quantity, availability and prices
 on B2B Chiaravalli





"T" METRIC TIMING PULLEYS

TYPE T 5

PITCH 5 mm

for belt width 25mm

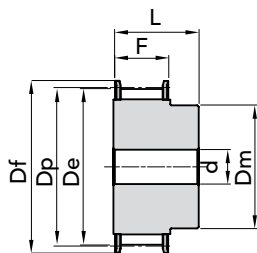

EXEC. 1F

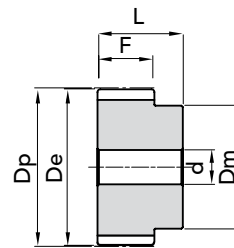

EXEC. 2

TYPE	P. NUMBER	EXEC.	N. TEETH	Dp	De	Df FLANGE	Dm HUB	F	L	d	N. FLANGE	WEIGHT Kg.
36 T5 10	45053610	1F	10	15,92	15,05	19,5	8	30	36	-	3	0,02
36 T5 12	45053612	1F	12	19,10	18,25	23,0	11	30	36	-	1	0,03
36 T5 14	45053614	1F	14	22,29	21,45	25,0	13	30	36	-	2	0,04
36 T5 15	45053615	1F	15	23,88	23,05	28,0	16	30	36	6	4	0,04
36 T5 16	45053616	1F	16	25,47	24,60	32,0	18	30	36	6	5	0,05
36 T5 18	45053618	1F	18	28,65	27,80	32,0	20	30	36	6	6	0,06
36 T5 19	45053619	1F	19	30,25	29,40	36,0	22	30	36	6	8	0,07
36 T5 20	45053620	1F	20	31,83	31,00	36,0	23	30	36	6	8	0,08
36 T5 22	45053622	1F	22	35,02	34,15	38,0	24	30	36	6	9	0,08
36 T5 24	45053624	1F	24	38,21	37,40	42,0	26	30	36	8	13	0,11
36 T5 25	45053625	1F	25	39,80	38,95	44,0	26	30	36	8	12	0,12
36 T5 26	45053626	1F	26	41,39	40,60	44,0	26	30	36	8	12	0,12
36 T5 27	45053627	1F	27	42,98	42,20	48,0	30	30	36	8	11	0,13
36 T5 28	45053628	1F	28	44,58	43,75	48,0	32	30	36	8	11	0,14
36 T5 30	45053630	1F	30	47,76	46,95	51,0	34	30	36	8	16	0,15
36 T5 32	45053632	1F	32	50,94	50,10	54,0	38	30	36	8	18	0,18
36 T5 36	45053636	1F	36	57,31	56,45	64,0	38	30	36	8	23	0,23
36 T5 40	45053640	1F	40	63,66	62,85	66,5	40	30	36	8	24	0,28
36 T5 42	45053642	1F	42	66,86	66,00	70,0	40	30	36	8	26	0,29
36 T5 44	45053644	2	44	70,05	69,20	-	45	30	36	8	-	0,31
36 T5 48	45053648	2	48	76,42	75,55	-	50	30	36	8	-	0,40
36 T5 60	45053660	2	60	95,52	94,65	-	65	30	36	8	-	0,61

MATERIAL ALUMINIUM

T20 pitch pulleys are manufactured on request.

CAD drawings available on our site www.chiaravalli.com

Quantity, availability and prices on B2B Chiaravalli



The images do not identify the products.

"T" METRIC TIMING PULLEYS TYPE T 5 (PITCH 5mm)



TYPE T 10

PITCH 10 mm

for belt width 16mm

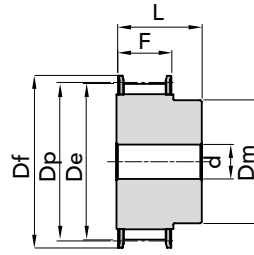

EXEC. 1F

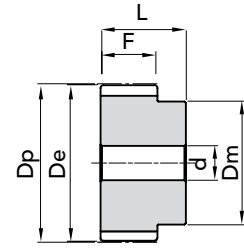

EXEC. 2

TYPE	P. NUMBER	EXEC.	N. TEETH	Dp	De	Df FLANGE	Dm HUB	F	L	d	N. FLANGE	WEIGHT Kg.
31 T10 12	45103112	1F	12	38,20	36,35	42,0	28	21	31	6	13	0,08
31 T10 14	45103114	1F	14	44,56	42,70	48,0	32	21	31	8	11	0,10
31 T10 15	45103115	1F	15	47,75	45,90	51,0	32	21	31	8	16	0,12
31 T10 16	45103116	1F	16	50,93	49,10	54,0	35	21	31	8	18	0,13
31 T10 18	45103118	1F	18	57,29	55,45	60,0	40	21	31	8	21	0,17
31 T10 19	45103119	1F	19	60,48	58,65	66,0	44	21	31	8	24	0,18
31 T10 20	45103120	1F	20	63,66	61,80	66,0	46	21	31	8	24	0,21
31 T10 22	45103122	1F	22	70,03	68,20	75,0	52	21	31	8	27	0,25
31 T10 24	45103124	1F	24	76,39	74,55	83,0	58	21	31	8	29	0,29
31 T10 25	45103125	1F	25	79,58	77,75	83,0	60	21	31	8	29	0,31
31 T10 26	45103126	1F	26	82,76	80,90	87,0	60	21	31	8	31	0,36
31 T10 27	45103127	1F	27	85,95	84,10	91,0	60	21	31	8	32	0,37
31 T10 28	45103128	1F	28	89,12	87,25	93,0	60	21	31	8	33	0,40
31 T10 30	45103130	1F	30	95,49	93,65	97,0	60	21	31	8	35	0,44
31 T10 32	45103132	1F	32	101,86	100,00	106,0	65	21	31	10	38	0,49
31 T10 36	45103136	1F	36	114,59	112,75	119,0	70	21	31	10	43	0,62
31 T10 40	45103140	1F	40	127,32	125,45	131,0	80	21	31	10	47	0,77
31 T10 44	45103144	2	44	140,05	138,20	-	88	21	31	10	-	1,00
31 T10 48	45103148	2	48	152,78	150,95	-	95	21	31	16	-	1,10
31 T10 60	45103160	2	60	190,98	189,10	-	110	21	31	16	-	1,70

MATERIAL ALUMINIUM

T20 pitch pulleys are manufactured on request.

CAD drawings available on our site
www.chiaravalli.com

Quantity, availability and prices
 on B2B Chiaravalli





TYPE T 10

PITCH 10 mm

for belt width 25mm

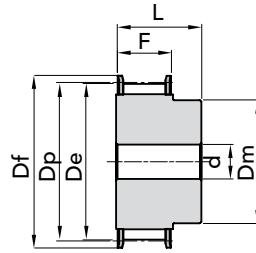

EXEC. 1F

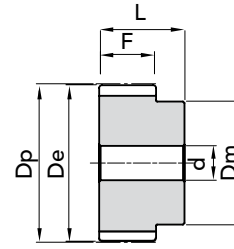

EXEC. 2

TYPE	P. NUMBER	EXEC.	N. TEETH	Dp	De	Df FLANGE	Dm HUB	F	L	d	N. FLANGE	WEIGHT kg.
40 T10 12	45104012	1F	12	38,20	36,35	42,0	28	30	40	6	13	0,10
40 T10 14	45104014	1F	14	44,56	42,70	48,0	32	30	40	8	11	0,13
40 T10 15	45104015	1F	15	47,75	45,90	51,0	32	30	40	8	16	0,15
40 T10 16	45104016	1F	16	50,93	49,10	54,0	35	30	40	8	18	0,18
40 T10 18	45104018	1F	18	57,29	55,45	60,0	40	30	40	8	21	0,22
40 T10 19	45104019	1F	19	60,48	58,65	66,0	44	30	40	8	24	0,25
40 T10 20	45104020	1F	20	63,66	61,80	66,0	46	30	40	8	24	0,28
40 T10 22	45104022	1F	22	70,03	68,20	75,0	52	30	40	8	27	0,34
40 T10 24	45104024	1F	24	76,39	74,55	83,0	58	30	40	8	29	0,39
40 T10 25	45104025	1F	25	79,58	77,75	83,0	60	30	40	8	29	0,42
40 T10 26	45104026	1F	26	82,76	80,90	87,0	60	30	40	8	31	0,48
40 T10 27	45104027	1F	27	85,95	84,10	91,0	60	30	40	8	32	0,54
40 T10 28	45104028	1F	28	89,12	87,25	93,0	60	30	40	8	33	0,55
40 T10 30	45104030	1F	30	95,49	93,65	97,0	60	30	40	8	35	0,64
40 T10 32	45104032	1F	32	101,86	100,00	106,0	65	30	40	10	38	0,69
40 T10 36	45104036	1F	36	114,59	112,75	119,0	70	30	40	10	43	0,87
40 T10 40	45104040	1F	40	127,32	125,45	131,0	80	30	40	10	47	1,07
40 T10 44	45104044	2	44	140,05	138,20	-	88	30	40	10	-	1,35
40 T10 48	45104048	2	48	152,78	150,95	-	95	30	40	16	-	1,52
40 T10 60	45104060	2	60	190,98	189,15	-	110	30	40	16	-	2,34

"T" METRIC TIMING PULLEYS TYPE T 10 (PITCH 10mm)

MATERIAL ALUMINIUM

T20 pitch pulleys are manufactured on request.

CAD drawings available on our site www.chiaravalli.com

Quantity, availability and prices on B2B Chiaravalli



The images do not identify the products.



TYPE T 10

PITCH 10 mm

for belt width 32mm

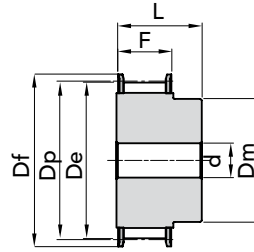

EXEC. 1F

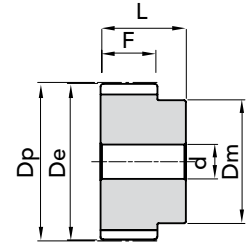

EXEC. 2

TYPE	P. NUMBER	EXEC.	N. TEETH	Dp	De	Df FLANGE	Dm HUB	F	L	d	N. FLANGE	WEIGHT Kg.
47 T10 18	45104718	1F	18	57,29	55,45	60,0	40	37	47	10	21	0,25
47 T10 19	45104719	1F	19	60,48	58,60	66,0	44	37	47	10	24	0,29
47 T10 20	45104720	1F	20	63,66	61,80	66,0	46	37	47	12	24	0,32
47 T10 22	45104722	1F	22	70,03	68,20	75,0	52	37	47	12	27	0,39
47 T10 24	45104724	1F	24	76,39	74,55	83,0	58	37	47	12	29	0,47
47 T10 25	45104725	1F	25	79,58	77,75	83,0	60	37	47	12	29	0,53
47 T10 26	45104726	1F	26	82,76	80,90	87,0	60	37	47	12	31	0,56
47 T10 27	45104727	1F	27	85,95	84,10	91,0	60	37	47	12	32	0,60
47 T10 28	45104728	1F	28	89,12	87,25	93,0	60	37	47	12	33	0,64
47 T10 30	45104730	1F	30	95,49	93,65	97,0	60	37	47	12	35	0,74
47 T10 32	45104732	1F	32	101,86	100,00	106,0	65	37	47	12	38	0,84
47 T10 36	45104736	1F	36	114,59	112,75	119,0	70	37	47	16	43	1,06
47 T10 40	45104740	1F	40	127,32	125,45	131,0	80	37	47	16	47	1,32
47 T10 44	45104744	2	44	140,05	138,20	-	88	37	47	16	-	1,61
47 T10 48	45104748	2	48	152,78	150,95	-	95	37	47	16	-	1,93
47 T10 60	45104760	2	60	190,98	189,10	-	110	37	47	16	-	3,00

MATERIAL ALUMINIUM

T20 pitch pulleys are manufactured on request.

CAD drawings available on our site
www.chiaravalli.com

Quantity, availability and prices
 on B2B Chiaravalli





"T" METRIC TIMING PULLEYS

TYPE T 10

PITCH 10 mm

for belt width 50mm

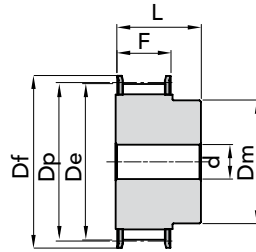

EXEC. 1F

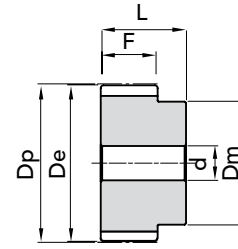

EXEC. 2

TYPE	P. NUMBER	EXEC.	N. TEETH	Dp	De	Df FLANGE	Dm HUB	F	L	d	N. FLANGE	WEIGHT Kg.
66 T10 18	45106618	1F	18	57,29	55,45	60,0	40	56	66	10	21	0,42
66 T10 19	45106619	1F	19	60,48	58,65	66,0	44	56	66	10	24	0,47
66 T10 20	45106620	1F	20	63,66	61,80	66,0	46	56	66	12	24	0,52
66 T10 22	45106622	1F	22	70,03	68,20	75,0	52	56	66	12	27	0,57
66 T10 24	45106624	1F	24	76,39	74,55	83,0	58	56	66	12	29	0,74
66 T10 25	45106625	1F	25	79,58	77,70	83,0	60	56	66	12	29	0,77
66 T10 26	45106626	1F	26	82,76	80,90	87,0	60	56	66	12	31	0,82
66 T10 27	45106627	1F	27	85,95	84,10	91,0	60	56	66	12	32	0,95
66 T10 28	45106628	1F	28	89,12	87,25	93,0	60	56	66	12	33	0,96
66 T10 30	45106630	1F	30	95,49	93,65	97,0	60	56	66	12	35	1,17
66 T10 32	45106632	1F	32	101,86	100,00	106,0	65	56	66	12	38	1,30
66 T10 36	45106636	1F	36	114,59	112,75	119,0	70	56	66	16	43	1,64
66 T10 40	45106640	1F	40	127,32	125,45	131,0	80	56	66	16	47	2,00
66 T10 44	45106644	2	44	140,05	138,20	-	88	56	66	16	-	2,36
66 T10 48	45106648	2	48	152,78	150,95	-	95	56	66	16	-	2,83
66 T10 60	45106660	2	60	190,98	189,10	-	110	56	66	16	-	4,37

"T" METRIC TIMING PULLEYS TYPE T 10 (PITCH 10mm)

MATERIAL ALUMINIUM

T20 pitch pulleys are manufactured on request.

CAD drawings available on our site www.chiaravalli.com

Quantity, availability and prices on B2B Chiaravalli



The images do not identify the products.



"CT" METRIC TIMING PULLEYS

DIMENSIONAL FEATURES

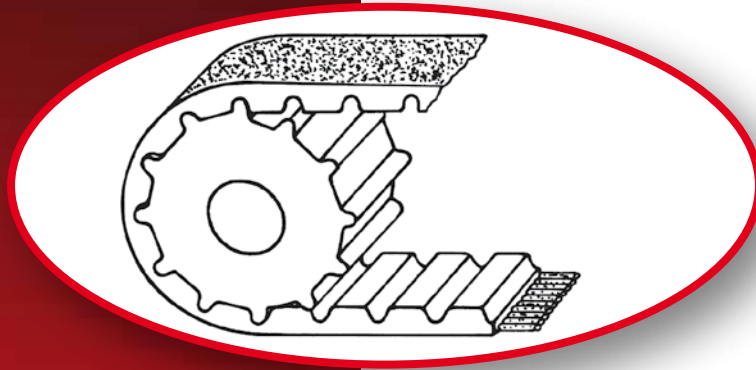

SYMBOLS

P	= Pitch
Z	= N° of teeth
$\varnothing p$	= Pulley pitch line
$\varnothing e$	= External diameter
Lp	= Pulley width
Lc	= Belt width
Lpc	= Belt pitch line length

16 - AT10 - 440

16	= Belt width in mm.
AT10	= Toothing pitch in mm.
440	= Pitch line length in mm.

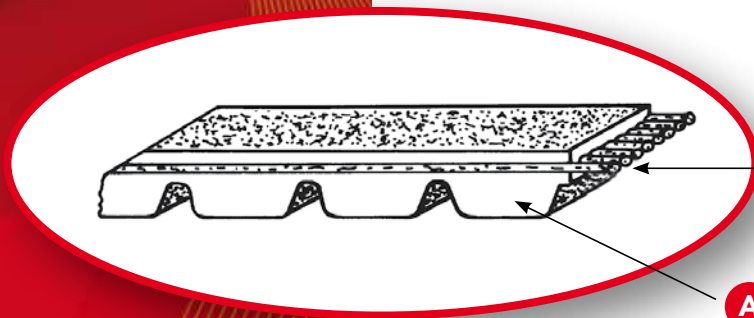

B
Steel reinforcing

A
Polyurethane belt body

N.B.

The "AT" profile represents an optimised version of the 'T' metric pitch, ensures enhanced belt meshing with subsequent reduced noise levels, the power transmitted is greater than ~ 30% compared with the 'T' version.

FIELDS OF APPLICATION:

machine tools, electrical household appliances, textile machines, packing machines, typewriters, sewing machines, etc.

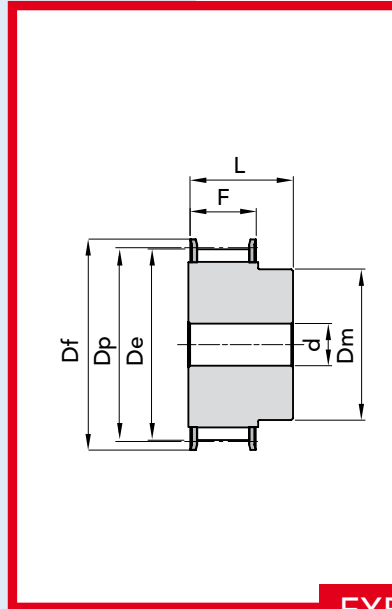

EXECUTION 1F

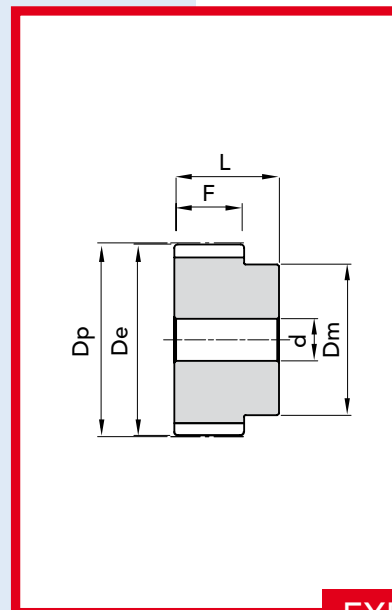

EXECUTION 2



TYPE **CT 5**

PITCH 5 mm

for belt width 10mm

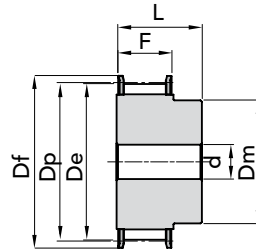

EXEC. 1F

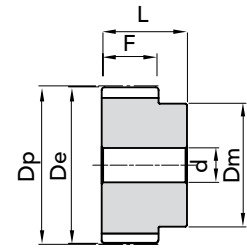

EXEC. 2

TYPE	P. NUMBER	EXEC.	N. TEETH	Dp	De	Df FLANGE	Dm HUB	F	L	d	N. FLANGE	WEIGHT Kg.
21 CT 5 Z 12	46052112	1F	12	19,10	17,85	23,0	11	15	21	-	1	0,01
21 CT 5 Z 14	46052114	1F	14	22,29	21,05	25,0	13	15	21	-	2	0,02
21 CT 5 Z 15	46052115	1F	15	23,88	22,65	28,0	16	15	21	6	4	0,02
21 CT 5 Z 16	46052116	1F	16	25,47	24,20	32,0	18	15	21	6	5	0,03
21 CT 5 Z 18	46052118	1F	18	28,65	27,40	32,0	20	15	21	6	6	0,03
21 CT 5 Z 19	46052119	1F	19	30,25	29,00	36,0	22	15	21	6	8	0,04
21 CT 5 Z 20	46052120	1F	20	31,83	30,60	36,0	23	15	21	6	8	0,04
21 CT 5 Z 22	46052122	1F	22	35,02	33,85	38,0	24	15	21	6	9	0,05
21 CT 5 Z 24	46052124	1F	24	38,21	37,00	42,0	26	15	21	6	13	0,06
21 CT 5 Z 25	46052125	1F	25	39,80	38,60	44,0	26	15	21	6	12	0,06
21 CT 5 Z 26	46052126	1F	26	41,39	40,20	44,0	26	15	21	6	12	0,06
21 CT 5 Z 27	46052127	1F	27	42,98	41,80	48,0	30	15	21	8	11	0,07
21 CT 5 Z 28	46052128	1F	28	44,58	43,35	48,0	32	15	21	8	11	0,07
21 CT 5 Z 30	46052130	1F	30	47,76	46,55	51,0	34	15	21	8	16	0,07
21 CT 5 Z 32	46052132	1F	32	50,94	49,70	54,0	38	15	21	8	18	0,09
21 CT 5 Z 36	46052136	1F	36	57,31	56,05	64,0	38	15	21	8	23	0,11
21 CT 5 Z 40	46052140	1F	40	63,66	62,45	66,5	40	15	21	8	24	0,14
21 CT 5 Z 42	46052142	1F	42	66,86	65,60	70,0	40	15	21	8	26	0,18
21 CT 5 Z 44	46052144	2	44	70,05	68,80	-	45	15	21	8	-	0,18
21 CT 5 Z 48	46052148	2	48	76,42	75,15	-	50	15	21	8	-	0,20
21 CT 5 Z 60	46052160	2	60	95,52	94,25	-	65	15	21	8	-	0,31

MATERIAL **ALUMINIUM**

CT 20 pitch pulleys are manufactured on request.

CAD drawings available on our site
www.chiaravalli.com

Quantity, availability and prices
 on B2B Chiaravalli





"CT" METRIC TIMING PULLEYS

TYPE CT 5

PITCH 5 mm

for belt width 16mm

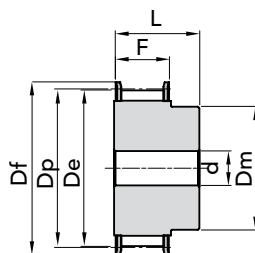

EXEC. 1F

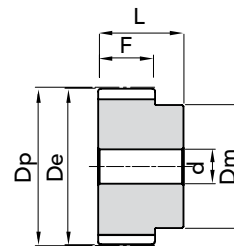

EXEC. 2

TYPE	P. NUMBER	EXEC.	N. TEETH	Dp	De	Df FLANGE	Dm HUB	F	L	d	N. FLANGE	WEIGHT Kg.
27 CT 5 Z 12	46052712	1F	12	19,10	17,85	23,0	11	21	27	-	1	0,02
27 CT 5 Z 14	46052714	1F	14	22,29	21,05	25,0	13	21	27	-	2	0,03
27 CT 5 Z 15	46052715	1F	15	23,88	22,65	28,0	16	21	27	6	4	0,03
27 CT 5 Z 16	46052716	1F	16	25,47	24,20	32,0	18	21	27	6	5	0,04
27 CT 5 Z 18	46052718	1F	18	28,65	27,40	32,0	20	21	27	6	6	0,04
27 CT 5 Z 19	46052719	1F	19	30,25	29,00	36,0	22	21	27	6	8	0,05
27 CT 5 Z 20	46052720	1F	20	31,83	30,60	36,0	23	21	27	6	8	0,06
27 CT 5 Z 22	46052722	1F	22	35,02	33,85	38,0	24	21	27	6	9	0,06
27 CT 5 Z 24	46052724	1F	24	38,21	37,00	42,0	26	21	27	6	13	0,08
27 CT 5 Z 25	46052725	1F	25	39,80	38,60	44,0	26	21	27	6	12	0,08
27 CT 5 Z 26	46052726	1F	26	41,39	40,20	44,0	26	21	27	6	12	0,09
27 CT 5 Z 27	46052727	1F	27	42,98	41,80	48,0	30	21	27	8	11	0,09
27 CT 5 Z 28	46052728	1F	28	44,58	43,35	48,0	32	21	27	8	11	0,09
27 CT 5 Z 30	46052730	1F	30	47,76	46,55	51,0	34	21	27	8	16	0,10
27 CT 5 Z 32	46052732	1F	32	50,94	49,70	54,0	38	21	27	8	18	0,12
27 CT 5 Z 36	46052736	1F	36	57,31	56,05	64,0	38	21	27	8	23	0,16
27 CT 5 Z 40	46052740	1F	40	63,66	62,45	66,5	40	21	27	8	24	0,19
27 CT 5 Z 42	46052742	1F	42	66,86	65,60	70,0	40	21	27	8	26	0,20
27 CT 5 Z 44	46052744	2	44	70,05	68,80	-	45	21	27	8	-	0,23
27 CT 5 Z 48	46052748	2	48	76,42	75,15	-	50	21	27	8	-	0,28
27 CT 5 Z 60	46052760	2	60	95,52	94,25	-	65	21	27	8	-	0,43

MATERIAL ALUMINIUM

CT 20 pitch pulleys are manufactured on request.

CAD drawings available on our site www.chiaravalli.com

Quantity, availability and prices on B2B Chiaravalli



The images do not identify the products.

"CT" METRIC TIMING PULLEYS TYPE CT 5 (PITCH 5mm)



TYPE CT 5

PITCH 5 mm

for belt width 25mm

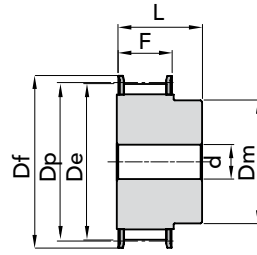

EXEC. 1F

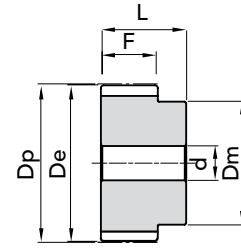

EXEC. 2

TYPE	P. NUMBER	EXEC.	N. TEETH	Dp	De	Df FLANGE	Dm HUB	F	L	d	N. FLANGE	WEIGHT Kg.
36 CT 5 Z 12	46053612	1F	12	19,10	17,85	23,0	11	30	36	-	1	0,03
36 CT 5 Z 14	46053614	1F	14	22,29	21,05	25,0	13	30	36	-	2	0,04
36 CT 5 Z 15	46053615	1F	15	23,88	22,65	28,0	16	30	36	6	4	0,04
36 CT 5 Z 16	46053616	1F	16	25,47	24,20	32,0	18	30	36	6	5	0,05
36 CT 5 Z 18	46053618	1F	18	28,65	27,40	32,0	20	30	36	6	6	0,06
36 CT 5 Z 19	46053619	1F	19	30,25	29,00	36,0	22	30	36	6	8	0,07
36 CT 5 Z 20	46053620	1F	20	31,83	30,60	36,0	23	30	36	6	8	0,08
36 CT 5 Z 22	46053622	1F	22	35,02	33,85	38,0	24	30	36	6	9	0,08
36 CT 5 Z 24	46053624	1F	24	38,21	37,00	42,0	26	30	36	6	13	0,11
36 CT 5 Z 25	46053625	1F	25	39,80	38,60	44,0	26	30	36	6	12	0,12
36 CT 5 Z 26	46053626	1F	26	41,39	40,20	44,0	26	30	36	6	12	0,12
36 CT 5 Z 27	46053627	1F	27	42,98	41,80	48,0	30	30	36	8	11	0,13
36 CT 5 Z 28	46053628	1F	28	44,58	43,35	48,0	32	30	36	8	11	0,14
36 CT 5 Z 30	46053630	1F	30	47,76	46,55	51,0	34	30	36	8	16	0,15
36 CT 5 Z 32	46053632	1F	32	50,94	49,70	54,0	38	30	36	8	18	0,18
36 CT 5 Z 36	46053636	1F	36	57,31	56,05	64,0	38	30	36	8	23	0,23
36 CT 5 Z 40	46053640	1F	40	63,66	62,45	66,5	40	30	36	8	24	0,28
36 CT 5 Z 42	46053642	1F	42	66,86	65,60	70,0	40	30	36	8	26	0,29
36 CT 5 Z 44	46053644	2	44	70,05	68,80	-	45	30	36	8	-	0,31
36 CT 5 Z 48	46053648	2	48	76,42	75,15	-	50	30	36	8	-	0,40
36 CT 5 Z 60	46053660	2	60	95,52	94,25	-	65	30	36	8	-	0,61

MATERIAL **ALUMINIUM**

CT 20 pitch pulleys are manufactured on request.

CAD drawings available on our site
www.chiaravalli.com

Quantity, availability and prices
 on B2B Chiaravalli





"CT" METRIC TIMING PULLEYS

TYPE CT 10

PITCH 10 mm

for belt width 16mm

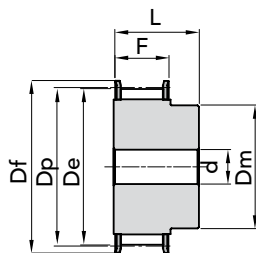

EXEC. 1F

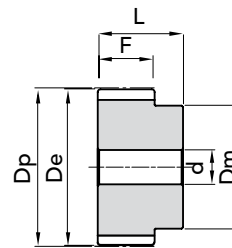

EXEC. 2

TYPE	P. NUMBER	EXEC.	N. TEETH	Dp	De	Df FLANGE	Dm HUB	F	L	d	N. FLANGE	WEIGHT Kg.
31 CT10 15	46103115	1F	15	47,75	45,90	51	32	21	31	8	16	0,12
31 CT10 16	46103116	1F	16	50,93	49,05	54	35	21	31	8	18	0,13
31 CT10 18	46103118	1F	18	57,29	55,45	60	40	21	31	8	21	0,17
31 CT10 19	46103119	1F	19	60,48	58,60	66,5	44	21	31	8	24	0,18
31 CT10 20	46103120	1F	20	63,66	61,80	66,5	46	21	31	8	24	0,21
31 CT10 22	46103122	1F	22	70,03	68,15	75	52	21	31	8	27	0,25
31 CT10 24	46103124	1F	24	76,39	74,55	83	58	21	31	8	29	0,29
31 CT10 25	46103125	1F	25	79,58	77,70	83	60	21	31	8	29	0,31
31 CT10 26	46103126	1F	26	82,76	80,90	87	60	21	31	8	31	0,36
31 CT10 27	46103127	1F	27	85,95	84,10	91	60	21	31	8	32	0,37
31 CT10 28	46103128	1F	28	89,12	87,25	93	60	21	31	8	33	0,40
31 CT10 30	46103130	1F	30	95,49	93,65	97	60	21	31	8	35	0,44
31 CT10 32	46103132	1F	32	101,86	100,00	106	65	21	31	10	38	0,49
31 CT10 36	46103136	1F	36	114,59	112,75	119	70	21	31	10	43	0,62
31 CT10 40	46103140	1F	40	127,32	125,45	131	80	21	31	10	47	0,77
31 CT10 44	46103144	2	44	140,05	138,20	-	88	21	31	10	-	1,00
31 CT10 48	46103148	2	48	152,78	150,95	-	95	21	31	16	-	1,10
31 CT10 60	46103160	2	60	190,98	189,10	-	110	21	31	16	-	1,70

"CT" METRIC TIMING PULLEYS TYPE CT 10 (PITCH 10mm)

MATERIAL ALUMINIUM

CT 20 pitch pulleys are manufactured on request.

CAD drawings available on our site www.chiaravalli.com

Quantity, availability and prices on B2B Chiaravalli



The images do not identify the products.



TYPE CT 10

PITCH 10 mm

for belt width 25mm

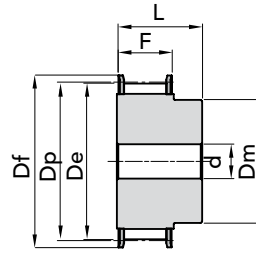

EXEC. 1F

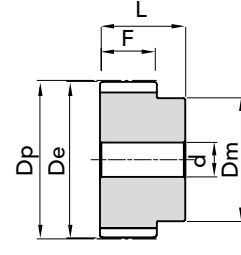

EXEC. 2

TYPE	P. NUMBER	EXEC.	N. TEETH	Dp	De	Df FLANGE	Dm HUB	F	L	d	N. FLANGE	WEIGHT Kg.
40 CT10 15	46104015	1F	15	47,75	45,90	51	32	30	40	8	16	0,15
40 CT10 16	46104016	1F	16	50,93	49,05	54	35	30	40	8	18	0,18
40 CT10 18	46104018	1F	18	57,29	55,45	60	40	30	40	8	21	0,22
40 CT10 19	46104019	1F	19	60,48	58,60	66,5	44	30	40	8	24	0,25
40 CT10 20	46104020	1F	20	63,66	61,80	66,5	46	30	40	8	24	0,28
40 CT10 22	46104022	1F	22	70,03	68,15	75	52	30	40	8	27	0,34
40 CT10 24	46104024	1F	24	76,39	74,55	83	58	30	40	8	29	0,39
40 CT10 25	46104025	1F	25	79,58	77,70	83	60	30	40	8	29	0,42
40 CT10 26	46104026	1F	26	82,76	80,90	87	60	30	40	8	31	0,48
40 CT10 27	46104027	1F	27	85,95	84,10	91	60	30	40	8	32	0,54
40 CT10 28	46104028	1F	28	89,12	87,25	93	60	30	40	8	33	0,55
40 CT10 30	46104030	1F	30	95,49	93,65	97	60	30	40	8	35	0,64
40 CT10 32	46104032	1F	32	101,86	100,00	106	65	30	40	10	38	0,69
40 CT10 36	46104036	1F	36	114,59	112,75	119	70	30	40	10	43	0,87
40 CT10 40	46104040	1F	40	127,32	125,45	131	80	30	40	10	47	1,07
40 CT10 44	46104044	2	44	140,05	138,20	-	88	30	40	10	-	1,35
40 CT10 48	46104048	2	48	152,78	150,95	-	95	30	40	16	-	1,52
40 CT10 60	46104060	2	60	190,98	189,10	-	110	30	40	16	-	2,34

MATERIAL **ALUMINIUM**

CT 20 pitch pulleys are manufactured on request.

CAD drawings available on our site
www.chiaravalli.com

Quantity, availability and prices
 on B2B Chiaravalli





"CT" METRIC TIMING PULLEYS

TYPE CT 10

PITCH 10 mm

for belt width 32mm

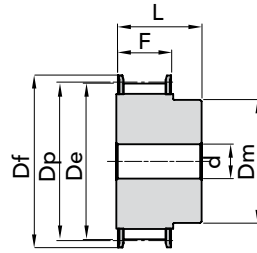

EXEC. 1F

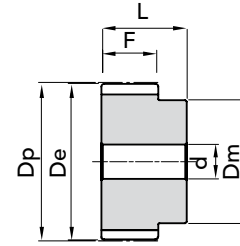

EXEC. 2

TYPE	P. NUMBER	EXEC.	N. TEETH	Dp	De	Df FLANGE	Dm HUB	F	L	d	N. FLANGE	WEIGHT Kg.
47 CT10 18	46104718	1F	18	57,29	55,45	60	40	37	47	10	21	0,25
47 CT10 19	46104719	1F	19	60,48	58,60	66,5	44	37	47	10	24	0,29
47 CT10 20	46104720	1F	20	63,66	61,80	66,5	46	37	47	12	24	0,32
47 CT10 22	46104722	1F	22	70,03	68,15	75	52	37	47	12	27	0,39
47 CT10 24	46104724	1F	24	76,39	74,55	83	58	37	47	12	29	0,47
47 CT10 25	46104725	1F	25	79,58	77,70	83	60	37	47	12	29	0,53
47 CT10 26	46104726	1F	26	82,76	80,90	87	60	37	47	12	31	0,56
47 CT10 27	46104727	1F	27	85,95	84,10	91	60	37	47	12	32	0,60
47 CT10 28	46104728	1F	28	89,12	87,25	93	60	37	47	12	33	0,64
47 CT10 30	46104730	1F	30	95,49	93,65	97	60	37	47	12	35	0,74
47 CT10 32	46104732	1F	32	101,86	100,00	106	65	37	47	12	38	0,84
47 CT10 36	46104736	1F	36	114,59	112,75	119	70	37	47	16	43	1,06
47 CT10 40	46104740	1F	40	127,32	125,45	131	80	37	47	16	47	1,32
47 CT10 44	46104744	2	44	140,05	138,20	-	88	37	47	16	-	1,61
47 CT10 48	46104748	2	48	152,78	150,95	-	95	37	47	16	-	1,93
47 CT10 60	46104760	2	60	190,98	189,10	-	110	37	47	16	-	3,00

"CT" METRIC TIMING PULLEYS TYPE CT 10 (PITCH 10mm)

MATERIAL ALUMINIUM

CT 20 pitch pulleys are manufactured on request.

CAD drawings available on our site www.chiaravalli.com

Quantity, availability and prices on B2B Chiaravalli



The images do not identify the products.



TYPE CT 10

PITCH 10 mm

for belt width 50mm

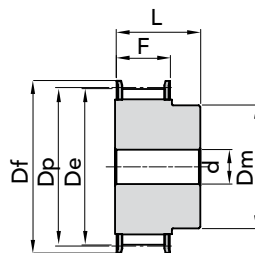

EXEC. 1F

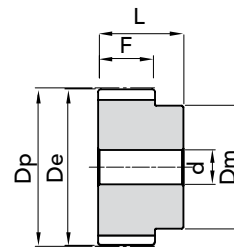

EXEC. 2

TYPE	P. NUMBER	EXEC.	N. TEETH	Dp	De	Df FLANGE	Dm HUB	F	L	d	N. FLANGE	WEIGHT Kg.
66 CT10 18	46106618	1F	18	57,29	55,45	60	40	56	66	10	21	0,42
66 CT10 19	46106619	1F	19	60,48	58,60	66,5	44	56	66	10	24	0,47
66 CT10 20	46106620	1F	20	63,66	61,80	66,5	46	56	66	12	24	0,52
66 CT10 22	46106622	1F	22	70,03	68,15	75	52	56	66	12	27	0,57
66 CT10 24	46106624	1F	24	76,39	74,55	83	58	56	66	12	29	0,74
66 CT10 25	46106625	1F	25	79,58	77,70	83	60	56	66	12	29	0,77
66 CT10 26	46106626	1F	26	82,76	80,90	87	60	56	66	12	31	0,82
66 CT10 27	46106627	1F	27	85,95	84,10	91	60	56	66	12	32	0,95
66 CT10 28	46106628	1F	28	89,12	87,25	93	60	56	66	12	33	0,96
66 CT10 30	46106630	1F	30	95,49	93,65	97	60	56	66	12	35	1,17
66 CT10 32	46106632	1F	32	101,86	100,00	106	65	56	66	12	38	1,30
66 CT10 36	46106636	1F	36	114,59	112,75	119	70	56	66	16	43	1,64
66 CT10 40	46106640	1F	40	127,32	125,45	131	80	56	66	16	47	2,00
66 CT10 44	46106644	2	44	140,05	138,20	-	88	56	66	16	-	2,36
66 CT10 48	46106648	2	48	152,78	150,95	-	95	56	66	16	-	2,83
66 CT10 60	46106660	2	60	190,98	189,10	-	110	56	66	16	-	4,37

MATERIAL **ALUMINIUM**

CT 20 pitch pulleys are manufactured on request.

CAD drawings available on our site
www.chiaravalli.com

Quantity, availability and prices
 on B2B Chiaravalli





V-BELT PULLEYS

V-BELT PULLEYS FOR TAPER BUSHES

SPZ	page 3
SPA	10
SPB	15
SPC	23

V-BELT PULLEYS PILOT BORE

SPA	31
SPB	36
SPC	42

V-BELT PULLEYS FOR LOCKING DEVICES

SPA	48
SPB	49
SPC	51

ADJUSTABLE V-BELT PULLEY PRB TYPE	52
--	----

V-BELT PULLEYS PPV-J MICRO V	57
-------------------------------------	----

V-BELT PULLEYS PPV-L MICRO V	58
-------------------------------------	----



CAST- IRON V-BELT PULLEYS

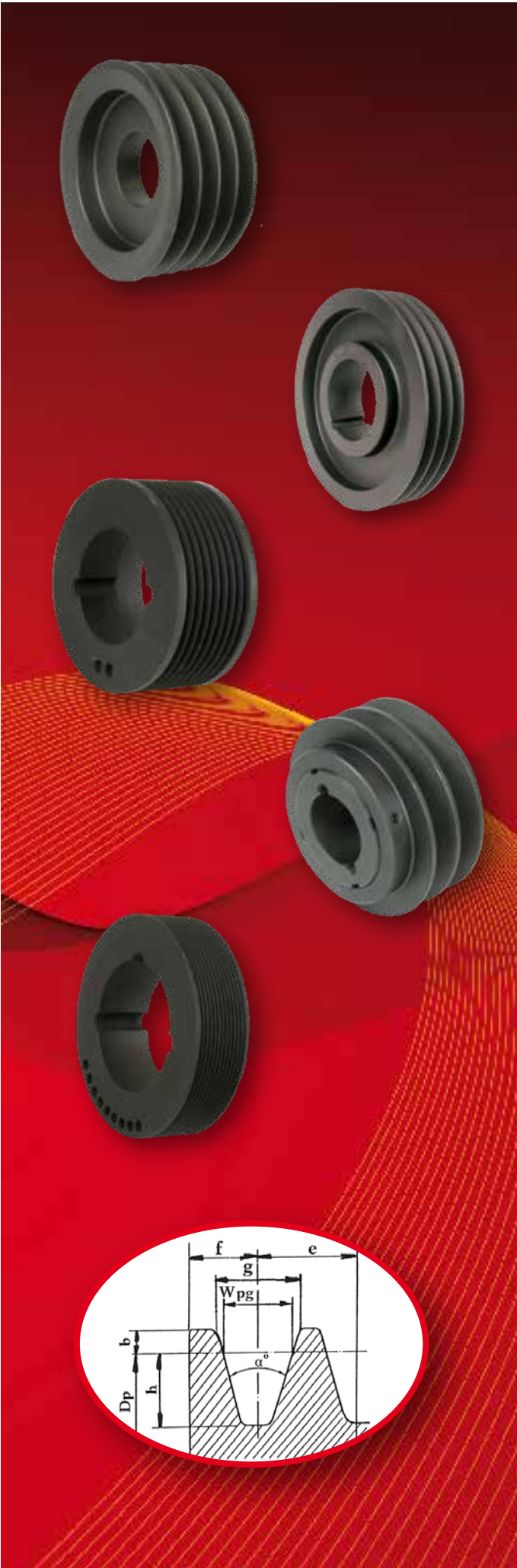

All V-belt pulleys are compliant with current legislation and are made of cast iron **GG 20** with protective phosphate.

Running in normal standard, the pulleys are statically balanced and this is sufficient for peripheral speeds up to **25 m/s**.

For higher speeds is essential dynamic balancing can be provided on request.

The Chiaravalli Group SpA is able to perform, upon request, balancing pulleys with diameters up to 630, with balancing CNC, accompanying certificate of balancing performed.

Over 35 m / sec, the pulleys in cast iron are not the most suitable and it requires the use of high-strength material.

D = diameter in meters

N = number of revolutions per minute

$$V_p = \frac{\pi \cdot D \cdot n}{60} = \frac{D \cdot n}{19,1} \text{ m/sec.}$$

Dimensions shown on the dimensional tables are not binding even if they are respected as far as possible.

We reserve the right to make variations and modifications without prior notice.

FEATURES OF THE GORGE

PROFILE	Dp mm	α°	W pg	g	h	b mm	f	e
SPZ	< 80	34°	8,5	9,7	9	2	8	12
	> 80	38°						
SPA	< 118	34°	11	12,7	11	2,8	10	15
	> 118	38°						
SPB	< 190	34°	14	16,3	14	3,5	12,5	19
	> 190	38°						
SPC	< 315	34°	19	22,0	19	4,8	17	25,5
	> 315	38°						

BAND WIDTH

N° GROOVES	SPZ	SPA	SPB	SPC
1	16	20	25	34
2	28	35	44	59,5
3	40	50	63	85
4	52	65	82	111
5	64	80	101	136
6		95	120	162
8			158	213
10			196	264

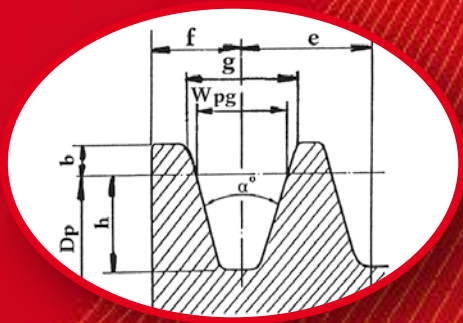



TAPER BUSHES

SPZ/01 TYPE

We are engaged to respect shapes and dimensions shown on this sheet but, we reserve the right to make changes and modifications without notice.

TYPE 1

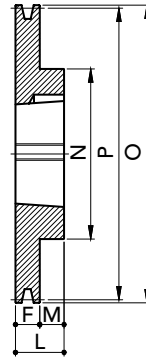

TYPE 4

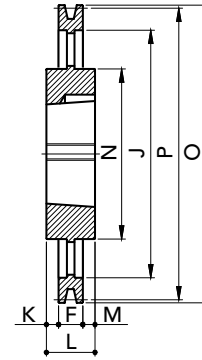

PRODUCT CODE	PRODUCT MODEL	GROOVES	P	O	TYPE	BUSH	MAX BORE	E	F	J	K	L	M	N	WEIGHT (Kg)
91100601	SPZ60-01	1	60	64	1	1008	25	-	22	-	-	22	-	-	0,3
91100631	SPZ63-01	1	63	67	1	1108	28	-	16	-	-	22	6	56	0,23
91100671	SPZ67-01	1	67	71	1	1108	28	-	16	-	-	22	6	60	0,3
91100711	SPZ71-01	1	71	75	1	1108	28	-	16	-	-	22	6	60	0,35
91100751	SPZ75-01	1	75	79	1	1108	28	-	16	-	-	22	6	60	0,4
91100801	SPZ80-01	1	80	84	1	1210	32	-	16	-	-	25	9	75	0,49
91100851	SPZ85-01	1	85	89	1	1210	32	-	16	-	-	25	9	80	0,6
91100901	SPZ90-01	1	90	94	1	1210	32	-	16	-	-	25	9	80	0,7
91100951	SPZ95-01	1	95	99	1	1210	32	-	16	-	-	25	9	85	0,8
91101001	SPZ100-01	1	100	104	1	1210	32	-	16	-	-	25	9	85	0,9
91101061	SPZ106-01	1	106	110	1	1610	42	-	16	-	-	25	9	92	0,92
91101121	SPZ112-01	1	112	116	1	1610	42	-	16	-	-	25	9	92	1,03
91101181	SPZ118-01	1	118	122	1	1610	42	-	16	-	-	25	9	92	1,16
91101251	SPZ125-01	1	125	129	1	1610	42	-	16	-	-	25	9	92	1,3
91101321	SPZ132-01	1	132	136	1	1610	42	-	16	-	-	25	9	92	1,45
91101401	SPZ140-01	1	140	144	1	1610	42	-	16	-	-	25	9	92	1,65
91101501	SPZ150-01	1	150	154	1	1610	42	-	16	-	-	25	9	92	1,92
91101601	SPZ160-01	1	160	164	1	1610	42	-	16	-	-	25	9	92	2,17
91101801	SPZ180-01	1	180	184	4	1610	42	-	16	152	-	25	9	92	1,9
91102001	SPZ200-01	1	200	204	4	2012	50	-	16	171	-	32	16	112	2,25
91102241	SPZ224-01	1	224	228	4	2012	50	-	16	195	-	32	16	112	2,93
91102501	SPZ250-01	1	250	254	4	2012	50	-	16	221	8	32	8	112	3,37
91102801	SPZ280-01	1	280	284	4	2012	50	-	16	251	8	32	8	112	3,7
91103151	SPZ315-01	1	315	319	4	2012	50	-	16	286	8	32	8	112	4,32
91103551	SPZ355-01	1	355	359	4	2012	50	-	16	326	8	32	8	112	5,1
91104001	SPZ400-01	1	400	404	4	2012	50	-	16	371	8	32	8	112	5,99
91104501	SPZ450-01	1	450	454	4	2517	60	-	16	421	14,5	45	14,5	124	7,19
91105001	SPZ500-01	1	500	504	4	2517	60	-	16	471	14,5	45	14,5	124	8,5

MATERIAL **CAST-IRON**

CAD drawings available on our site
www.chiaravalli.com

Quantity, availability and prices
 on B2B Chiaravalli



V-BELT PULLEYS for TAPER BUSHES

TAPER BUSHES

SPZ/02 TYPE

We are engaged to respect shapes and dimensions shown on this sheet but, we reserve the right to make changes and modifications without notice.

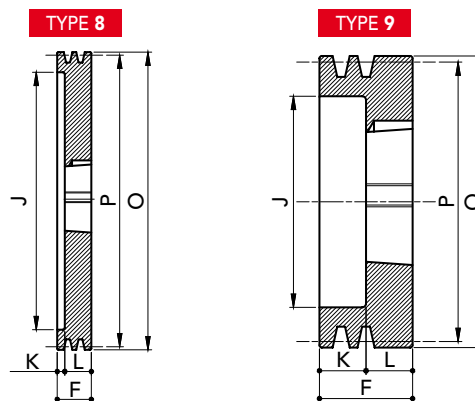

PRODUCT CODE	PRODUCT MODEL	GROOVES	P	O	TYPE	BUSH	MAX BORE	E	F	J	K	L	M	N	WEIGHT (Kg)
91100602	SPZ60-02	2	60	64	9	1108	28	-	49	36	27	22	-	-	0,6
91100632	SPZ63-02	2	63	67	8	1108	28	-	28	40	6	22	-	-	0,3
91100672	SPZ67-02	2	67	71	8	1108	28	-	28	42	6	22	-	-	0,36
91100712	SPZ71-02	2	71	75	8	1108	28	-	28	42	6	22	-	-	0,45
91100752	SPZ75-02	2	75	79	8	1210	32	-	28	51	3	25	-	-	0,41
91100802	SPZ80-02	2	80	84	8	1210	32	-	28	51	3	25	-	-	0,52
91100852	SPZ85-02	2	85	89	8	1610	42	-	28	60	3	25	-	-	0,5
91100902	SPZ90-02	2	90	94	8	1610	42	-	28	61	3	25	-	-	0,63
91100952	SPZ95-02	2	95	99	8	1610	42	-	28	66	3	25	-	-	0,74
91101002	SPZ100-02	2	100	104	8	1610	42	-	28	71	3	25	-	-	0,9
91101062	SPZ106-02	2	106	110	8	1610	42	-	28	76	3	25	-	-	1,05
91101122	SPZ112-02	2	112	116	8	1610	42	-	28	83	3	25	-	-	1,25
91101182	SPZ118-02	2	118	122	8	1610	42	-	28	90	3	25	-	-	1,45
91101252	SPZ125-02	2	125	129	8	1610	42	-	28	96	3	25	-	-	1,65

MATERIAL **CAST-IRON**

CAD drawings available on our site www.chiaravalli.com

Quantity, availability and prices on B2B Chiaravalli



TAPER BUSHES

SPZ/02 TYPE

We are engaged to respect shapes and dimensions shown on this sheet but, we reserve the right to make changes and modifications without notice.

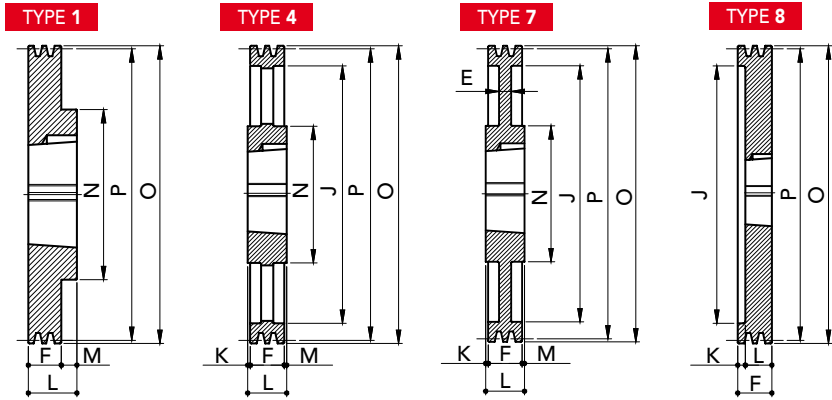

PRODUCT CODE	PRODUCT MODEL	GROOVES	P	O	TYPE	BUSH	MAX BORE	E	F	J	K	L	M	N	WEIGHT (Kg)
91101322	SPZ132-02	2	132	136	8	1610	42	-	28	103	3	25	-	-	1,9
91101402	SPZ140-02	2	140	144	8	1610	42	-	28	111	3	25	-	-	2,22
91101502	SPZ150-02	2	150	154	1	2012	50	-	28	-	-	32	4	112	2,74
91101602	SPZ160-02	2	160	164	1	2012	50	-	28	-	-	32	4	112	3,23
91101802	SPZ180-02	2	180	184	7	2012	50	10	28	152	-	32	4	112	3,18
91101902	SPZ190-02	2	190	194	7	2012	50	10	28	162	-	32	4	112	3,45
91102002	SPZ200-02	2	200	204	4	2012	50	-	28	171	-	32	4	112	4,2
91102242	SPZ224-02	2	224	228	4	2012	50	-	28	195	-	32	4	112	3,86
91102502	SPZ250-02	2	250	254	4	2012	50	-	28	221	2	32	2	112	4,22
91102802	SPZ280-02	2	280	284	4	2012	50	-	28	251	2	32	2	112	4,85
91103152	SPZ315-02	2	315	319	4	2012	50	-	28	286	2	32	2	112	5,49
91103552	SPZ355-02	2	355	359	4	2012	50	-	28	326	2	32	2	112	6,19
91104002	SPZ400-02	2	400	404	4	2517	60	-	28	371	8,5	45	8,5	124	8,95
91104502	SPZ450-02	2	450	454	4	2517	60	-	28	421	8,5	45	8,5	124	9,9
91105002	SPZ500-02	2	500	504	4	2517	60	-	28	471	8,5	45	8,5	124	10,25

V-BELT PULLEYS for TAPER BUSHES

MATERIAL **CAST-IRON**

CAD drawings available on our site
www.chiaravalli.com

Quantity, availability and prices
 on B2B Chiaravalli

TAPER BUSHES
SPZ/03 TYPE

We are engaged to respect shapes and dimensions shown on this sheet but, we reserve the right to make changes and modifications without notice.

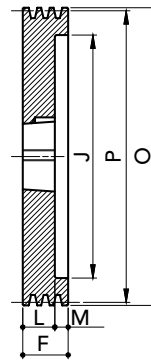
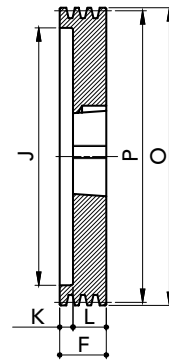
TYPE 2

TYPE 8

PRODUCT CODE	PRODUCT MODEL	GROOVES	P	O	TYPE	BUSH	MAX BORE	E	F	J	K	L	M	N	WEIGHT (Kg)
91100633	SPZ63-03	3	63	67	8	1108	28	-	40	40	18	22	-	-	0,41
91100673	SPZ67-03	3	67	71	8	1108	28	-	40	42	18	22	-	-	0,5
91100713	SPZ71-03	3	71	75	8	1108	28	-	40	42	18	22	-	-	0,53
91100753	SPZ75-03	3	75	79	8	1210	32	-	40	51	15	25	-	-	0,56
91100803	SPZ80-03	3	80	84	8	1210	32	-	40	51	15	25	-	-	0,7
91100853	SPZ85-03	3	85	89	8	1610	42	-	40	60	15	25	-	-	0,65
91100903	SPZ90-03	3	90	94	8	1610	42	-	40	61	15	25	-	-	0,84
91100953	SPZ95-03	3	95	99	8	1610	42	-	40	66	15	25	-	-	0,99
91101003	SPZ100-03	3	100	104	8	1610	42	-	40	71	15	25	-	-	1,12
91101063	SPZ106-03	3	106	110	8	1610	42	-	40	76	15	25	-	-	1,35
91101123	SPZ112-03	3	112	116	8	2012	50	-	40	83	8	32	-	-	1,37
91101183	SPZ118-03	3	118	122	8	2012	50	-	40	90	8	32	-	-	1,65
91101253	SPZ125-03	3	125	129	2	2012	50	-	40	96	-	32	8	-	1,9
91101323	SPZ132-03	3	132	136	2	2012	50	-	40	103	-	32	8	-	2,27
91101403	SPZ140-03	3	140	144	2	2012	50	-	40	111	-	32	8	-	2,7
91101503	SPZ150-03	3	150	154	2	2012	50	-	40	121	-	32	8	-	3,16
91101603	SPZ160-03	3	160	164	2	2012	50	-	40	131	-	32	8	-	3,77

 MATERIAL **CAST-IRON**

 CAD drawings available on our site
www.chiaravalli.com

 Quantity, availability and prices
 on B2B Chiaravalli



TAPER BUSHES

SPZ/03 TYPE

We are engaged to respect shapes and dimensions shown on this sheet but, we reserve the right to make changes and modifications without notice.

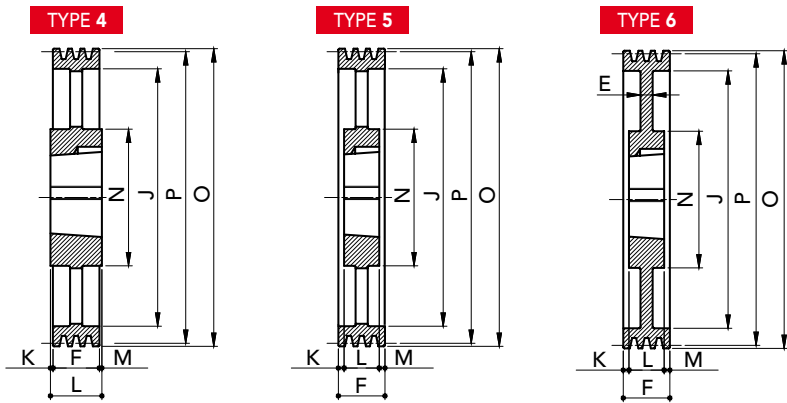

PRODUCT CODE	PRODUCT MODEL	GROOVES	P	O	TYPE	BUSH	MAX BORE	E	F	J	K	L	M	N	WEIGHT (Kg)
91101803	SPZ180-03	3	180	184	6	2012	50	7	40	151	-	32	8	106	3,36
91101903	SPZ190-03	3	190	194	6	2012	50	10	40	161	4	32	4	112	3,95
91102003	SPZ200-03	3	200	204	5	2012	50	-	40	171	4	32	4	112	4,15
91102243	SPZ224-03	3	224	228	5	2012	50	-	40	195	4	32	4	112	4,68
91102503	SPZ250-03	3	250	254	5	2012	60	-	40	221	4	32	4	112	5,35
91102803	SPZ280-03	3	280	284	4	2517	60	-	40	251	2,5	45	2,5	124	6,53
91103153	SPZ315-03	3	315	319	4	2517	60	-	40	286	2,5	45	2,5	124	7,3
91103553	SPZ355-03	3	355	359	4	2517	60	-	40	326	2,5	45	2,5	124	8,86
91104003	SPZ400-03	3	400	404	4	2517	60	-	40	371	2,5	45	2,5	124	10,5
91104503	SPZ450-03	3	450	454	4	2517	60	-	40	421	2,5	45	2,5	124	11,6
91105003	SPZ500-03	3	500	504	4	2517	60	-	40	471	2,5	45	2,5	124	13,3

V-BELT PULLEYS for TAPER BUSHES

MATERIAL **CAST-IRON**

CAD drawings available on our site www.chiaravalli.com

Quantity, availability and prices on B2B Chiaravalli



TAPER BUSHES

SPZ/04 TYPE

We are engaged to respect shapes and dimensions shown on this sheet but, we reserve the right to make changes and modifications without notice.

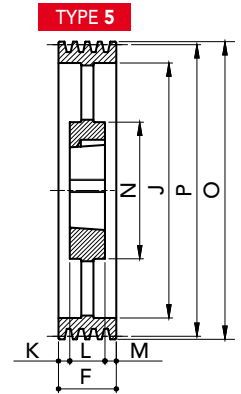
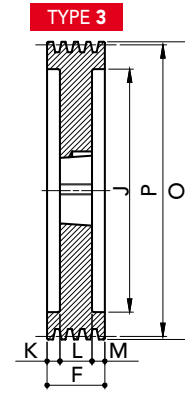
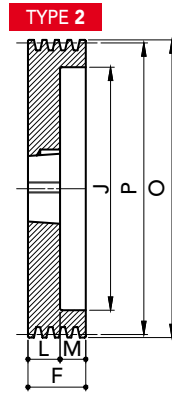

PRODUCT CODE	PRODUCT MODEL	GROOVES	P	O	TYPE	BUSH	MAX BORE	E	F	J	K	L	M	N	WEIGHT (Kg)
91100804	SPZ80-04	4	80	84	8	1210	32	-	52	51	27	25	-	-	0,87
91100854	SPZ85-04	4	85	89	8	1610	42	-	52	60	27	25	-	-	0,84
91100904	SPZ90-04	4	90	94	8	1610	42	-	52	61	27	25	-	-	1,08
91100954	SPZ95-04	4	95	99	8	1610	42	-	52	66	27	25	-	-	1,21
91101004	SPZ100-04	4	100	104	8	1610	42	-	52	71	27	25	-	-	1,38
91101064	SPZ106-04	4	106	110	8	1610	42	-	52	76	27	25	-	-	1,6
91101124	SPZ112-04	4	112	116	8	2012	50	-	52	83	20	32	-	-	1,65
91101184	SPZ118-04	4	118	122	8	2012	50	-	52	90	20	32	-	-	1,97
91101254	SPZ125-04	4	125	129	2	2012	50	-	52	96	-	32	20	-	2,24
91101324	SPZ132-04	4	132	136	2	2012	50	-	52	103	-	32	20	-	2,6
91101404	SPZ140-04	4	140	144	2	2012	50	-	52	111	-	32	20	-	3
91101504	SPZ150-04	4	150	154	2	2517	60	-	52	121	-	45	7	-	3,75
91101604	SPZ160-04	4	160	164	2	2517	60	-	52	131	-	45	7	-	4,45
91101804	SPZ180-04	4	180	184	2	2517	60	-	52	151	-	45	7	-	6,2
91101904	SPZ190-04	4	190	194	3	2517	60	-	52	161	3,5	45	3,5	-	7,1
91102004	SPZ200-04	4	200	204	6	2517	60	8	52	171	3,5	45	3,5	124	5,23
91102244	SPZ224-04	4	224	228	5	2517	60	-	52	195	3,5	45	3,5	124	6,43
91102504	SPZ250-04	4	250	254	5	2517	60	-	52	221	3,5	45	3,5	124	7,5
91102804	SPZ280-04	4	280	284	5	2517	60	-	52	251	3,5	45	3,5	124	9,4
91103154	SPZ315-04	4	315	319	5	2517	60	-	52	286	3,5	45	3,5	124	8,45
91103554	SPZ355-04	4	355	359	5	2517	60	-	52	326	3,5	45	3,5	124	10,37
91104004	SPZ400-04	4	400	404	5	2517	60	-	52	371	3,5	45	3,5	124	12,94
91104504	SPZ450-04	4	450	454	5	3020	75	-	52	421	0,5	51	0,5	146	15,92
91105004	SPZ500-04	4	500	504	5	3020	75	-	52	471	0,5	51	0,5	146	18

MATERIAL CAST-IRON

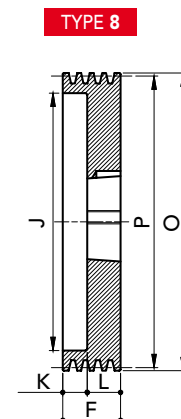
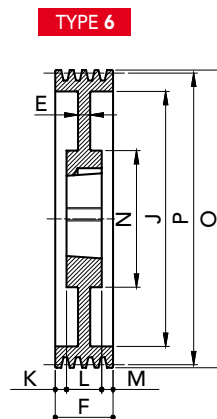

CAD drawings available on our site
www.chiaravalli.com

Quantity, availability and prices
 on B2B Chiaravalli



TAPER BUSHES

SPZ/05 TYPE

We are engaged to respect shapes and dimensions shown on this sheet but, we reserve the right to make changes and modifications without notice.

TYPE 2

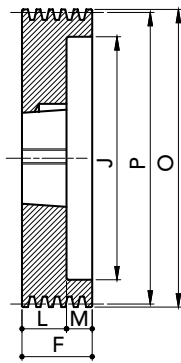

TYPE 3

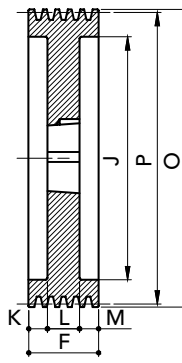

TYPE 4

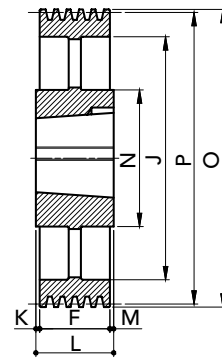

V-BELT PULLEYS for TAPER BUSHES

PRODUCT CODE	PRODUCT MODEL	GROOVES	P	O	TYPE	BUSH	MAX BORE	E	F	J	K	L	M	N	WEIGHT (Kg)
91100855	SPZ85-05	5	85	89	8	1610	42	-	64	60	39	25	-	-	1
91100905	SPZ90-05	5	90	94	8	1610	42	-	64	61	39	25	-	-	1,29
91100955	SPZ95-05	5	95	99	8	1610	42	-	64	66	39	25	-	-	1,45
91101005	SPZ100-05	5	100	104	8	2012	50	-	64	71	32	32	-	-	1,4
91101065	SPZ106-05	5	106	110	8	2012	50	-	64	76	32	32	-	-	1,72
91101125	SPZ112-05	5	112	116	8	2012	50	-	64	83	32	32	-	-	1,9
91101185	SPZ118-05	5	118	122	8	2012	50	-	64	90	32	32	-	-	2,2
91101255	SPZ125-05	5	125	129	8	2012	50	-	64	96	32	32	-	-	2,63
91101325	SPZ132-05	5	132	136	8	2517	60	-	64	103	19	45	-	-	2,75
91101405	SPZ140-05	5	140	144	2	2517	60	-	64	111	-	45	19	-	3,34
91101505	SPZ150-05	5	150	154	2	2517	60	-	64	121	-	45	19	-	4,15
91101605	SPZ160-05	5	160	164	2	2517	60	-	64	131	-	45	19	-	4,93
91101805	SPZ180-05	5	180	184	2	2517	60	-	64	151	-	45	19	-	6,72
91102005	SPZ200-05	5	200	204	3	2517	60	-	64	171	9,5	45	9,5	-	8,63
91102245	SPZ224-05	5	224	228	5	2517	60	-	64	195	9,5	45	9,5	124	7,59
91102505	SPZ250-05	5	250	254	5	2517	60	-	64	221	9,5	45	9,5	124	8,3
91102805	SPZ280-05	5	280	284	5	2517	60	-	64	251	9,5	45	9,5	124	9
91103155	SPZ315-05	5	315	319	5	2517	60	-	64	286	9,5	45	9,5	124	10,14
91103555	SPZ355-05	5	355	359	5	2517	60	-	64	326	9,5	45	9,5	124	11,96
91104005	SPZ400-05	5	400	404	5	3020	75	-	64	371	6,5	51	6,5	146	14,5
91104505	SPZ450-05	5	450	454	5	3020	75	-	64	421	6,5	51	6,5	146	17,55
91105005	SPZ500-05	5	500	504	4	3030	75	-	64	471	6	76	6	146	21,15

MATERIAL CAST-IRON

CAD drawings available on our site
www.chiaravalli.com

TYPE 5

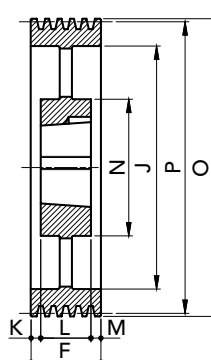

TYPE 8

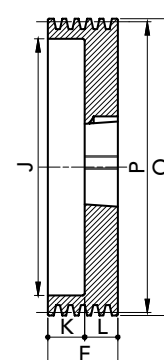

Quantity, availability and prices
 on B2B Chiaravalli



TAPER BUSHES

SPA/01 TYPE

We are engaged to respect shapes and dimensions shown on this sheet but, we reserve the right to make changes and modifications without notice.

TYPE 1

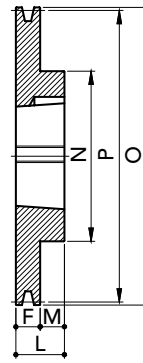

TYPE 4

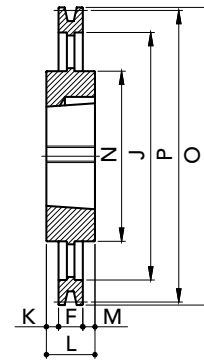

PRODUCT CODE	PRODUCT MODEL	GROOVES	P	O	TYPE	BUSH	MAX BORE	E	F	J	K	L	M	N	WEIGHT (Kg)
91200631	SPA63-01	1	63	68,5	1	1008	25	-	20	-	-	22	2	56	0,26
91200711	SPA71-01	1	71	76,5	1	1108	28	-	20	-	-	22	2	60	0,35
91200751	SPA75-01	1	75	80,5	1	1108	28	-	20	-	-	22	2	60	0,4
91200801	SPA80-01	1	80	85,5	1	1210	32	-	20	-	-	25	5	75	0,46
91200851	SPA85-01	1	85	90,5	1	1210	32	-	20	-	-	25	5	80	0,55
91200901	SPA90-01	1	90	95,5	1	1210	42	-	20	-	-	25	5	80	0,65
91200951	SPA95-01	1	95	100,5	1	1210	32	-	20	-	-	25	5	85	0,79
91201001	SPA100-01	1	100	105,5	1	1610	42	-	20	-	-	25	5	85	0,75
91201061	SPA106-01	1	106	111,5	1	1610	42	-	20	-	-	25	5	92	0,92
91201121	SPA112-01	1	112	117,5	1	1610	42	-	20	-	-	25	5	92	1,06
91201181	SPA118-01	1	118	123,5	1	1610	42	-	20	-	-	25	5	92	1,2
91201251	SPA125-01	1	125	130,5	1	1610	42	-	20	-	-	25	5	92	1,41
91201321	SPA132-01	1	132	137,5	1	1610	42	-	20	-	-	25	5	92	1,6
91201401	SPA140-01	1	140	145,5	1	1610	42	-	20	-	-	25	5	92	1,85
91201501	SPA150-01	1	150	155,5	1	1610	42	-	20	-	-	25	5	92	2,15
91201601	SPA160-01	1	160	165,5	1	1610	42	-	20	-	-	25	5	92	2,5
91201701	SPA170-01	1	170	175,5	1	1610	42	-	20	-	-	25	5	92	2,85
91201801	SPA180-01	1	180	185,5	4	1610	42	-	20	145	-	25	5	92	2,21
91201901	SPA190-01	1	190	195,5	4	1610	42	-	20	156	-	25	5	92	2,31
91202001	SPA200-01	1	200	205,5	4	2012	50	-	20	165	-	32	12	108	3
91202121	SPA212-01	1	212	217,5	4	2012	50	-	20	177	-	32	12	110	3,1
91202241	SPA224-01	1	224	229,5	4	2012	50	-	20	189	-	32	12	112	3,33
91202361	SPA236-01	1	236	241,5	4	2012	50	-	20	202	-	32	12	112	3,62
91202501	SPA250-01	1	250	255,5	4	2012	50	-	20	215	6	32	6	112	3,73
91202801	SPA280-01	1	280	285,5	4	2012	50	-	20	245	-	32	12	112	4,08
91203001	SPA300-01	1	300	305,5	4	2012	50	-	20	265	-	32	12	112	4,62
91203151	SPA315-01	1	315	320,5	4	2012	50	-	20	280	-	32	12	112	4,75
91203551	SPA355-01	1	355	360,5	4	2012	50	-	20	320	-	32	12	112	5,57
91204001	SPA400-01	1	400	405,5	4	2012	50	-	20	365	-	32	12	112	6,4
91204501	SPA450-01	1	450	455,5	4	2012	50	-	20	415	-	32	12	112	7,45
91205001	SPA500-01	1	500	505,5	4	2517	60	-	20	465	-	45	25	124	9,3

MATERIAL **CAST-IRON**

CAD drawings available on our site
www.chiaravalli.com

Quantity, availability and prices
 on B2B Chiaravalli



TAPER BUSHES

SPA/02 TYPE

We are engaged to respect shapes and dimensions shown on this sheet but, we reserve the right to make changes and modifications without notice.

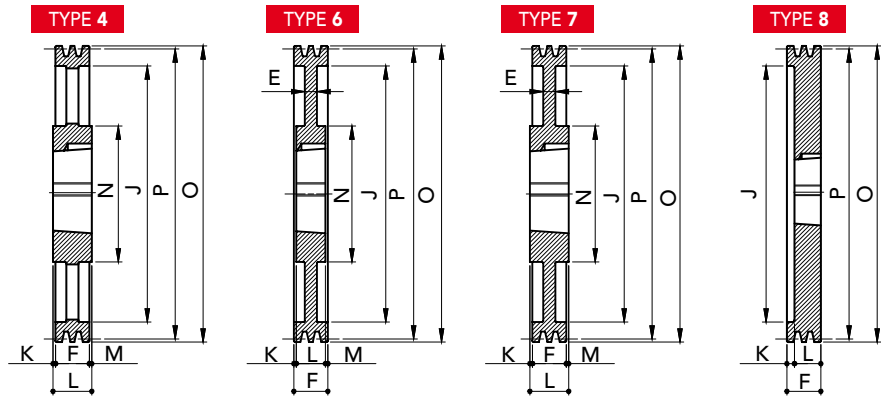

PRODUCT CODE	PRODUCT MODEL	GROOVES	P	O	TYPE	BUSH	MAX BORE	E	F	J	K	L	M	N	WEIGHT (Kg)
91200712	SPA71-02	2	71	76,5	8	1108	28	-	35	40	13	22	-	-	0,51
91200752	SPA75-02	2	75	80,5	8	1108	28	-	35	44	13	22	-	-	0,59
91200802	SPA80-02	2	80	85,5	8	1210	32	-	35	50	10	25	-	-	0,55
91200852	SPA85-02	2	85	90,5	8	1210	32	-	35	55	10	25	-	-	0,7
91200902	SPA90-02	2	90	95,5	8	1610	42	-	35	59	10	25	-	-	0,7
91200952	SPA95-02	2	95	100,5	8	1610	42	-	35	63	10	25	-	-	0,83
91201002	SPA100-02	2	100	105,5	8	1610	42	-	35	66	10	25	-	-	1
91201062	SPA106-02	2	106	111,5	8	1610	42	-	35	72	10	25	-	-	1,15
91201122	SPA112-02	2	112	117,5	8	1610	42	-	35	78	10	25	-	-	1,39
91201182	SPA118-02	2	118	123,5	8	1610	42	-	35	84	10	25	-	-	1,57
91201252	SPA125-02	2	125	130,5	8	1610	42	-	35	91	10	25	-	-	1,85
91201322	SPA132-02	2	132	137,5	8	2012	50	-	35	98	3	32	-	-	2,1
91201402	SPA140-02	2	140	145,5	8	2012	50	-	35	106	3	32	-	-	2,25
91201502	SPA150-02	2	150	155,5	8	2012	50	-	35	116	3	32	-	-	3
91201602	SPA160-02	2	160	165,5	8	2012	50	-	35	125	3	32	-	-	3,5
91201702	SPA170-02	2	170	175,5	8	2012	50	-	35	135	3	32	-	-	4,1
91201802	SPA180-02	2	180	185,5	6	2012	50	10	35	146	1,5	32	1,5	108	3,54
91201902	SPA190-02	2	190	195,5	6	2012	50	10	35	156	1,5	32	1,5	108	3,84
91202002	SPA200-02	2	200	205,5	7	2517	60	10	35	165	5	45	5	123	4,7
91202122	SPA212-02	2	212	217,5	4	2517	60	-	35	177	5	45	5	123	4,93
91202242	SPA224-02	2	224	229,5	4	2517	60	-	35	189	-	45	10	124	5,17
91202362	SPA236-02	2	236	241,5	4	2517	60	-	35	202	-	45	10	124	5,2
91202502	SPA250-02	2	250	255,5	4	2517	60	-	35	215	5	45	5	124	5,82
91202802	SPA280-02	2	280	285,5	4	2517	60	-	35	245	-	45	10	124	6,45
91203002	SPA300-02	2	300	305,5	4	2517	60	-	35	265	-	45	10	124	6,95
91203152	SPA315-02	2	315	320,5	4	2517	60	-	35	280	-	45	10	124	7,34
91203552	SPA355-02	2	355	360,5	4	2517	60	-	35	320	-	45	10	124	9,36
91204002	SPA400-02	2	400	405,5	4	2517	60	-	35	365	-	45	10	124	10,2
91204502	SPA450-02	2	450	455,5	4	2517	60	-	35	415	-	45	10	124	11,64
91205002	SPA500-02	2	500	505,5	4	2517	60	-	35	465	-	45	10	125	13,25
91206302	SPA630-02	2	630	635,5	4	3020	75	-	35	595	8	51	8	159	19,1

MATERIAL **CAST-IRON**

CAD drawings available on our site
www.chiaravalli.com

Quantity, availability and prices
 on B2B Chiaravalli



TAPER BUSHES

SPA/03 TYPE

We are engaged to respect shapes and dimensions shown on this sheet but, we reserve the right to make changes and modifications without notice.

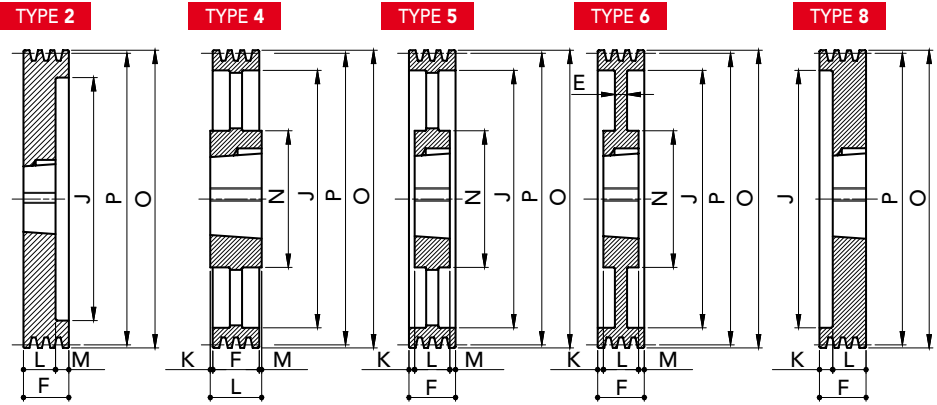

PRODUCT CODE	PRODUCT MODEL	GROOVES	P	O	TYPE	BUSH	MAX BORE	E	F	J	K	L	M	N	WEIGHT (Kg)
91200713	SPA71-03	3	71	76,5	8	1108	28	-	50	40	28	22	-	-	0,7
91200753	SPA75-03	3	75	80,5	8	1108	28	-	50	44	28	22	-	-	0,8
91200803	SPA80-03	3	80	85,5	8	1210	32	-	50	50	25	25	-	-	0,8
91200853	SPA85-03	3	85	90,5	8	1210	32	-	50	55	25	25	-	-	0,94
91200903	SPA90-03	3	90	95,5	8	1610	42	-	50	59	25	25	-	-	0,95
91200953	SPA95-03	3	95	100,5	8	1610	42	-	50	63	25	25	-	-	1,12
91201003	SPA100-03	3	100	105,5	2	1610	42	-	50	66	-	25	25	-	1,3
91201063	SPA106-03	3	106	111,5	2	1610	42	-	50	72	-	25	25	-	1,52
91201123	SPA112-03	3	112	117,5	8	2012	50	-	50	78	18	32	-	-	1,57
91201183	SPA118-03	3	118	123,5	2	2012	50	-	50	84	-	32	18	-	1,85
91201253	SPA125-03	3	125	130,5	2	2012	50	-	50	91	-	32	18	-	2,2
91201323	SPA132-03	3	132	137,5	2	2012	50	-	50	98	-	32	18	-	2,53
91201403	SPA140-03	3	140	145,5	8	2517	60	-	50	106	5	45	-	-	2,87
91201503	SPA150-03	3	150	155,5	8	2517	60	-	50	116	5	45	-	-	3,55
91201603	SPA160-03	3	160	165,5	8	2517	60	-	50	125	5	45	-	-	4,33
91201703	SPA170-03	3	170	175,5	8	2517	60	-	50	135	5	45	-	-	5,1
91201803	SPA180-03	3	180	185,5	8	2517	60	-	50	146	5	45	-	-	6
91201903	SPA190-03	3	190	195,5	8	2517	60	-	50	156	5	45	-	-	6,92
91202003	SPA200-03	3	200	205,5	6	2517	60	20	50	165	2,5	45	2,5	123	6,15
91202123	SPA212-03	3	212	217,5	5	2517	60	-	50	177	2,5	45	2,5	123	6,03
91202243	SPA224-03	3	224	229,5	5	2517	60	-	50	189	2,5	45	2,5	124	6,4
91202363	SPA236-03	3	236	241,5	5	2517	60	-	50	202	2,5	45	2,5	124	6,8
91202503	SPA250-03	3	250	255,5	5	2517	60	-	50	215	2,5	45	2,5	124	7,25
91202803	SPA280-03	3	280	285,5	5	2517	60	-	50	245	2,5	45	2,5	124	8,15
91203003	SPA300-03	3	300	305,5	4	3020	75	-	50	265	0,5	51	0,5	150	10,04
91203153	SPA315-03	3	315	320,5	4	3020	75	-	50	280	0,5	51	0,5	159	11,32
91203353	SPA335-03	3	335	340,5	4	3020	75	-	50	300	0,5	51	0,5	159	12,04
91203553	SPA355-03	3	355	360,5	4	3020	75	-	50	320	0,5	51	0,5	159	12,75
91204003	SPA400-03	3	400	405,5	4	3020	75	-	50	365	/	51	1	159	14,46
91204503	SPA450-03	3	450	455,5	4	3020	75	-	50	415	/	51	1	159	16,7
91205003	SPA500-03	3	500	505,5	4	3020	75	/	50	465	/	51	1	159	19,17
91205603	SPA560-03	3	560	565,5	4	3020	75	/	50	525	/	51	1	159	21,45
91206303	SPA630-03	3	630	635,5	4	3020	75	/	50	595	/	51	1	159	25,2
91208003	SPA800-03	3	800	805,5	4	3535	90	/	50	765	19,5	89	19,5	175	40

MATERIAL CAST-IRON

CAD drawings available on our site
www.chiaravalli.com

Quantity, availability and prices
 on B2B Chiaravalli



TAPER BUSHES

SPA/04 TYPE

We are engaged to respect shapes and dimensions shown on this sheet but, we reserve the right to make changes and modifications without notice.

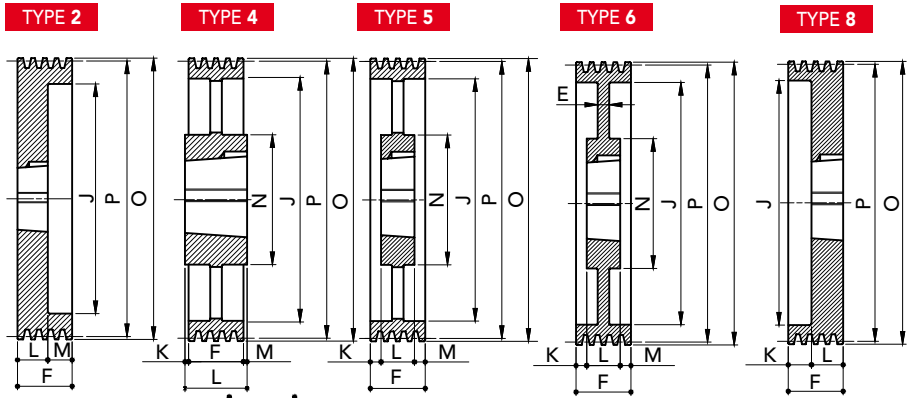

V-BELT PULLEYS for TAPER BUSHES

PRODUCT CODE	PRODUCT MODEL	GROOVES	P	O	TYPE	BUSH	MAX BORE	E	F	J	K	L	M	N	WEIGHT (Kg)
91200954	SPA95-04	4	95	100,5	8	1615	42	-	65	63	27	38	-	-	1,5
91201004	SPA100-04	4	100	105,5	2	1615	42	-	65	66	-	38	27	-	1,75
91201064	SPA106-04	4	106	111,5	8	2012	50	-	65	72	33	32	-	-	1,66
91201124	SPA112-04	4	112	117,5	8	2012	50	-	65	78	33	32	-	-	1,9
91201184	SPA118-04	4	118	123,5	2	2012	50	-	65	84	-	32	33	-	2,22
91201254	SPA125-04	4	125	130,5	2	2012	50	-	65	91	-	32	33	-	2,63
91201324	SPA132-04	4	132	137,5	2	2517	60	-	65	98	-	45	20	-	2,79
91201404	SPA140-04	4	140	145,5	2	2517	60	-	65	106	-	45	20	-	3,35
91201504	SPA150-04	4	150	155,5	2	2517	60	-	65	116	-	45	20	-	4,05
91201604	SPA160-04	4	160	165,5	2	2517	60	-	65	125	-	45	20	-	4,9
91201704	SPA170-04	4	170	175,5	2	2517	60	-	65	135	-	45	20	-	5,75
91201804	SPA180-04	4	180	185,5	2	2517	60	-	65	146	-	45	20	-	6,65
91201904	SPA190-04	4	190	195,5	2	2517	60	-	65	156	-	45	20	-	7,55
91202004	SPA200-04	4	200	205,5	2	3020	75	-	65	165	-	51	14	-	8,1
91202124	SPA212-04	4	212	217,5	2	3020	75	-	65	177	-	51	14	-	9,55
91202244	SPA224-04	4	224	229,5	2	3020	75	-	65	189	-	51	14	-	11,06
91202364	SPA236-04	4	236	241,5	6	3020	75	20	56	202	-	51	14	159	9,85
91202504	SPA250-04	4	250	255,5	5	3020	75	-	65	215	7	51	7	159	9,95
91202804	SPA280-04	4	280	285,5	5	3020	75	-	65	245	7	51	7	159	11,4
91203004	SPA300-04	4	300	305,5	5	3020	75	-	65	265	7	51	7	159	12,25
91203154	SPA315-04	4	315	320,5	5	3020	75	-	65	280	7	51	7	159	12,95
91203354	SPA335-04	4	335	340,5	5	3020	75	-	65	300	7	51	7	159	13,5
91203554	SPA355-04	4	355	360,5	5	3020	75	-	65	320	7	51	7	159	14,48
91204004	SPA400-04	4	400	405,5	5	3020	75	-	65	365	7	51	7	159	16,42
91204504	SPA450-04	4	450	455,5	5	3020	75	-	65	415	7	51	7	159	19,45
91205004	SPA500-04	4	500	505,5	5	3020	75	-	65	465	7	51	7	159	21,9
91205604	SPA560-04	4	560	565,5	4	3535	90	-	65	525	12	89	12	175	28,5
91206304	SPA630-04	4	630	635,5	4	3535	90	-	65	595	12	89	12	175	32,55
91208004	SPA800-04	4	800	805,5	4	3535	90	/	65	765	12	89	12	175	45,05

MATERIAL CAST-IRON

CAD drawings available on our site
www.chiaravalli.com

Quantity, availability and prices
 on B2B Chiaravalli



TAPER BUSHES

SPA/05 TYPE

We are engaged to respect shapes and dimensions shown on this sheet but, we reserve the right to make changes and modifications without notice.

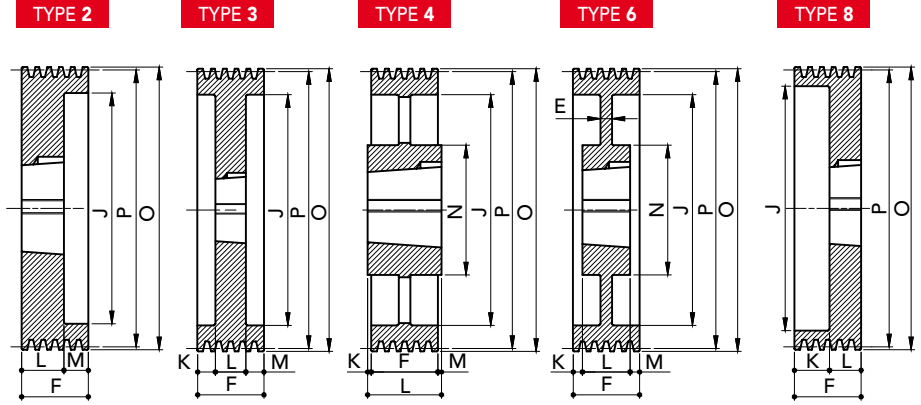

PRODUCT CODE	PRODUCT MODEL	GROOVES	P	O	TYPE	BUSH	MAX BORE	E	F	J	K	L	M	N	WEIGHT (Kg)
91201005	SPA100-05	5	100	105,5	2	1615	42	-	80	66	-	38	42	-	2,06

MATERIAL **CAST-IRON**

CAD drawings available on our site
www.chiaravalli.com

Quantity, availability and prices
 on B2B Chiaravalli



TAPER BUSHES

SPB/01 TYPE

We are engaged to respect shapes and dimensions shown on this sheet but, we reserve the right to make changes and modifications without notice.

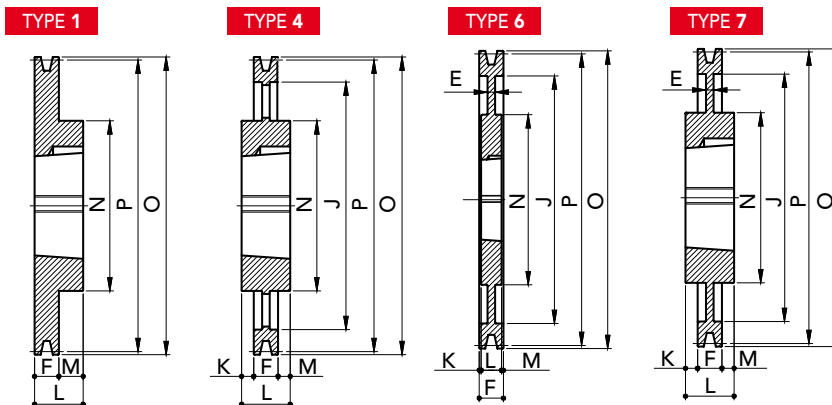

PRODUCT CODE	PRODUCT MODEL	GROOVES	P	O	TYPE	BUSH	MAX BORE	E	F	J	K	L	M	N	WEIGHT (Kg)
91301001	SPB100-01	1	100	107	1	1610	42	-	25	-	-	25	-	-	0,76
91301061	SPB106-01	1	106	113	1	1610	42	-	25	-	-	25	-	-	0,9
91301121	SPB112-01	1	112	119	1	1610	42	-	25	-	-	25	-	-	1,1
91301181	SPB118-01	1	118	125	1	1610	42	-	25	-	-	25	-	-	1,25
91301251	SPB125-01	1	125	132	1	1610	42	-	25	-	-	25	-	-	1,5
91301321	SPB132-01	1	132	139	1	1610	42	-	25	-	-	25	-	-	1,7
91301401	SPB140-01	1	140	147	1	1610	42	-	25	-	-	25	-	-	2
91301501	SPB150-01	1	150	157	1	1610	42	-	25	-	-	25	-	-	2,4
91301601	SPB160-01	1	160	167	1	1610	42	-	25	-	-	25	-	-	2,8
91301701	SPB170-01	1	170	177	1	1610	42	-	25	-	-	25	-	-	3,2
91301801	SPB180-01	1	180	187	6	1610	42	12	25	132	-	25	-	90	3,03
91301901	SPB190-01	1	190	197	7	2012	50	12	25	147	3,5	32	3,5	104	3,45
91302001	SPB200-01	1	200	207	4	2012	50	-	25	157	3,5	32	3,5	104	3,52
91302121	SPB212-01	1	212	219	4	2012	50	-	25	169	3,5	32	3,5	104	3,75
91302241	SPB224-01	1	224	231	4	2012	50	-	25	181	3,5	32	3,5	104	4
91302361	SPB236-01	1	236	243	4	2012	50	-	25	193	3,5	32	3,5	104	4,1
91302501	SPB250-01	1	250	257	4	2012	50	-	25	207	3,5	32	3,5	104	4,45
91302801	SPB280-01	1	280	287	4	2012	50	-	25	237	3,5	32	3,5	104	5,17
91303001	SPB300-01	1	300	307	4	2012	50	-	25	258	3,5	32	3,5	104	5,45
91303151	SPB315-01	1	315	322	4	2012	50	-	25	272	3,5	32	3,5	104	6,05

MATERIAL **CAST-IRON**

CAD drawings available on our site
www.chiaravalli.com

Quantity, availability and prices
 on B2B Chiaravalli



TAPER BUSHES

SPB/02 TYPE

We are engaged to respect shapes and dimensions shown on this sheet but, we reserve the right to make changes and modifications without notice.

TYPE 1

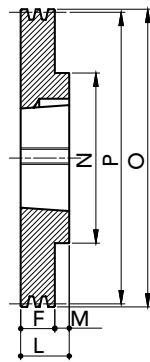

TYPE 2

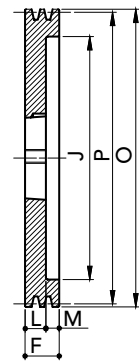

TYPE 4

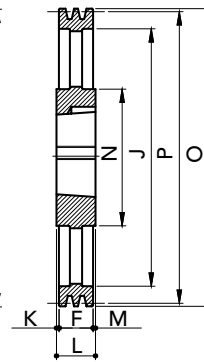

TYPE 7

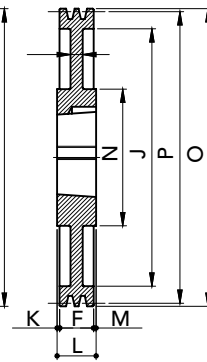

TYPE 8

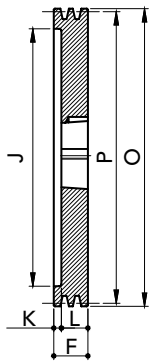

PRODUCT CODE	PRODUCT MODEL	GROOVES	P	O	TYPE	BUSH	MAX BORE	E	F	J	K	L	M	N	WEIGHT (Kg)
91301002	SPB100-02	2	100	107	8	1610	42	-	44	62	19	25	-	-	1,16
91301062	SPB106-02	2	106	113	8	1610	42	-	44	67	19	25	-	-	1,35
91301122	SPB112-02	2	112	119	8	1610	42	-	44	72	19	25	-	-	1,6
91301182	SPB118-02	2	118	125	2	1610	42	-	44	78	-	25	19	-	1,83
91301252	SPB125-02	2	125	132	2	2012	50	-	44	82	-	32	12	-	2,2
91301322	SPB132-02	2	132	139	2	2012	50	-	44	89	-	32	12	-	2,33
91301402	SPB140-02	2	140	147	2	2012	50	-	44	97	-	32	12	-	2,71
91301502	SPB150-02	2	150	157	2	2012	50	-	44	107	-	32	12	-	3,25
91301602	SPB160-02	2	160	167	2	2012	50	-	44	117	-	32	12	-	3,8
91301702	SPB170-02	2	170	177	2	2012	50	-	44	127	-	32	12	-	4,4
91301802	SPB180-02	2	180	187	1	2517	60	-	44	-	-	45	1	120	5,45
91301902	SPB190-02	2	190	197	1	2517	60	-	44	-	-	45	1	120	6,3
91302002	SPB200-02	2	200	207	1	2517	60	-	44	-	-	45	1	117	7,3
91302122	SPB212-02	2	212	219	7	2517	60	15	44	169	-	45	1	117	6,05
91302242	SPB224-02	2	224	231	4	2517	60	-	44	181	-	45	1	117	5,84
91302362	SPB236-02	2	236	243	4	2517	60	-	44	193	-	45	1	117	6,28
91302502	SPB250-02	2	250	257	4	2517	60	-	44	207	-	45	1	125	7
91302802	SPB280-02	2	280	287	4	2517	60	-	44	237	-	45	1	125	8,06
91303002	SPB300-02	2	300	307	4	2517	60	-	44	257	-	45	1	125	8,67
91303152	SPB315-02	2	315	322	4	2517	60	-	44	272	-	45	1	125	9,15
91303352	SPB335-02	2	335	342	4	2517	60	-	44	292	-	45	1	125	9,82
91303552	SPB355-02	2	355	362	4	3020	75	-	44	312	3,5	51	3,5	144	10,98
91304002	SPB400-02	2	400	407	4	3020	75	-	44	357	3,5	51	3,5	150	13,6
91304502	SPB450-02	2	450	457	4	3020	75	-	44	407	3,5	51	3,5	150	15,2
91305002	SPB500-02	2	500	507	4	3020	75	-	44	457	3,5	51	3,5	150	17,14
91305602	SPB560-02	2	560	567	4	3030	75	-	44	517	4	76	28	150	21,55

MATERIAL CAST-IRON

CAD drawings available on our site
www.chiaravalli.com

Quantity, availability and prices
 on B2B Chiaravalli



TAPER BUSHES

SPB/03 TYPE

We are engaged to respect shapes and dimensions shown on this sheet but, we reserve the right to make changes and modifications without notice.

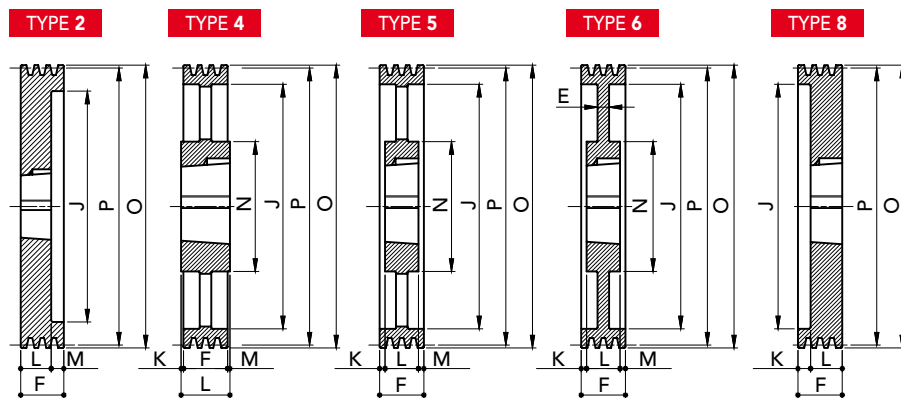

V-BELT PULLEYS for TAPER BUSHES

PRODUCT CODE	PRODUCT MODEL	GROOVES	P	O	TYPE	BUSH	MAX BORE	E	F	J	K	L	M	N	WEIGHT (Kg)
91301063	SPB106-03	3	106	113	8	1610	42	-	63	67	38	25	-	-	1,8
91301123	SPB112-03	3	112	119	8	1610	42	-	63	72	38	25	-	-	2,08
91301183	SPB118-03	3	118	125	2	1610	42	-	63	78	-	25	38	-	2,35
91301253	SPB125-03	3	125	132	2	2012	50	-	63	82	-	32	31	-	2,6
91301323	SPB132-03	3	132	139	2	2012	50	-	63	89	-	32	31	-	3
91301403	SPB140-03	3	140	147	2	2012	50	-	63	97	-	32	31	-	3,45
91301503	SPB150-03	3	150	157	2	2517	60	-	63	107	-	45	18	-	3,9
91301603	SPB160-03	3	160	167	2	2517	60	-	63	117	-	45	18	-	4,72
91301703	SPB170-03	3	170	177	2	2517	60	-	63	127	-	45	18	-	5,55
91301803	SPB180-03	3	180	187	2	2517	60	-	63	137	-	45	18	-	6,42
91301903	SPB190-03	3	190	197	2	2517	60	-	63	147	-	45	18	-	7,37
91302003	SPB200-03	3	200	207	2	2517	60	-	63	157	-	45	18	-	8,55
91302123	SPB212-03	3	212	219	6	2517	60	15	63	169	-	45	18	117	7,37
91302243	SPB224-03	3	224	231	5	2517	60	-	63	181	-	45	18	117	7,47
91302363	SPB236-03	3	236	243	5	2517	60	-	63	193	-	45	18	117	7,95
91302503	SPB250-03	3	250	257	5	3020	75	-	63	207	-	51	12	144	9,53
91302803	SPB280-03	3	280	287	5	3020	75	-	63	237	6	51	6	144	10,86
91303003	SPB300-03	3	300	307	5	3020	75	-	63	257	6	51	6	144	11,45
91303153	SPB315-03	3	315	322	5	3020	75	-	63	272	6	51	6	144	12,25
91303353	SPB335-03	3	335	342	5	3020	75	-	63	292	6	51	6	144	12,75
91303553	SPB355-03	3	355	362	5	3020	75	-	63	312	6	51	6	144	14,85
91304003	SPB400-03	3	400	407	4	3535	90	-	63	357	13	89	13	175	20,95
91304503	SPB450-03	3	450	457	4	3535	90	-	63	407	-	89	26	175	24,5
91305003	SPB500-03	3	500	507	4	3535	90	-	63	457	-	89	26	175	27,5
91305603	SPB560-03	3	560	567	4	3535	90	-	63	517	-	89	26	175	29,32
91306303	SPB630-03	3	630	637	4	3535	90	-	63	587	-	89	26	175	35,1
91307103	SPB710-03	3	710	717	4	3535	90	-	63	664	13	89	13	175	42,3
91308003	SPB800-03	3	800	807	4	3535	90	-	63	754	13	89	13	175	48,75
91309003	SPB900-03	3	900	907	4	3535	90	-	63	854	13	89	13	175	55,5
91310003	SPB1000-03	3	1000	1007	4	4040	100	-	63	954	19,5	102	19,5	210	76,4
91312503	SPB1250-03	3	1250	1257	4	4040	100	-	63	1204	19,5	102	19,5	210	102

MATERIAL **CAST-IRON**

CAD drawings available on our site
www.chiaravalli.com

Quantity, availability and prices
 on B2B Chiaravalli



TAPER BUSHES

SPB/04 TYPE

We are engaged to respect shapes and dimensions shown on this sheet but, we reserve the right to make changes and modifications without notice.

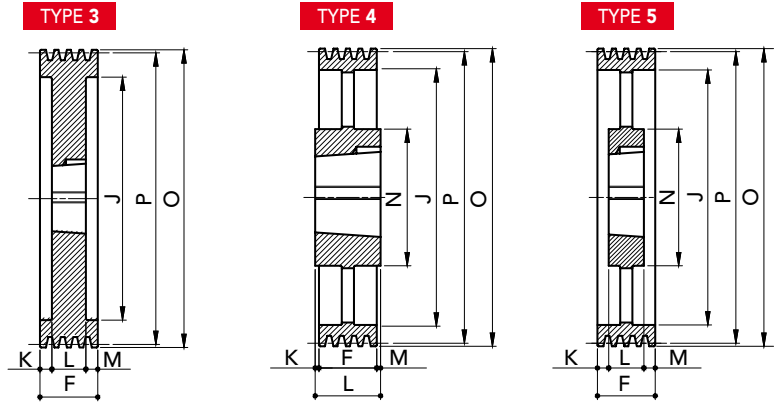

PRODUCT CODE	PRODUCT MODEL	GROOVES	P	O	TYPE	BUSH	MAX BORE	E	F	J	K	L	M	N	WEIGHT (Kg)
91301254	SPB125-04	4	125	132	3	2012	50	-	82	82	25	32	25	-	3,27
91301324	SPB132-04	4	132	139	3	2012	50	-	82	89	25	32	25	-	3,65
91301404	SPB140-04	4	140	147	3	2517	60	-	82	100	18,5	45	18,5	-	3,76
91301504	SPB150-04	4	150	157	3	2517	60	-	82	107	18,5	45	18,5	-	4,7
91301604	SPB160-04	4	160	167	3	2517	60	-	82	117	18,5	45	18,5	-	5,55
91301704	SPB170-04	4	170	177	3	2517	60	-	82	127	18,5	45	18,5	-	6,48
91301804	SPB180-04	4	180	187	3	2517	60	-	82	137	18,5	45	18,5	-	7,4
91301904	SPB190-04	4	190	197	3	2517	60	-	82	147	18,5	45	18,5	-	8,4
91302004	SPB200-04	4	200	207	3	3020	75	-	82	157	15,5	51	15,5	-	9,14
91302124	SPB212-04	4	212	219	3	3020	75	-	82	169	15,5	51	15,5	-	10,6
91302244	SPB224-04	4	224	231	3	3020	75	-	82	181	15,5	51	15,5	-	12,1
91302364	SPB236-04	4	236	243	3	3020	75	-	82	193	15,5	51	15,5	-	13,8
91302504	SPB250-04	4	250	257	5	3020	75	-	82	207	15,5	51	15,5	144	11,2
91302804	SPB280-04	4	280	287	5	3020	75	-	82	237	15,5	51	15,5	144	12,95
91303004	SPB300-04	4	300	307	4	3535	90	-	82	257	-	89	7	175	18,25
91303154	SPB315-04	4	315	322	4	3535	90	-	82	272	3,5	89	3,5	175	19,25
91303354	SPB335-04	4	335	342	4	3535	90	-	82	292	3,5	89	3,5	175	20,75
91303554	SPB355-04	4	355	362	4	3535	90	-	82	312	3,5	89	3,5	175	21,62
91303754	SPB375-04	4	375	382	4	3535	90	-	82	332	3,5	89	3,5	175	23,05
91304004	SPB400-04	4	400	407	4	3535	90	-	82	357	3,5	89	3,5	175	24,76
91304504	SPB450-04	4	450	457	4	3535	90	-	82	407	-	89	7	175	27,83
91305004	SPB500-04	4	500	507	4	3535	90	-	82	457	-	89	7	175	30,84
91305604	SPB560-04	4	560	567	4	3535	90	-	82	517	-	89	7	175	36,05
91306304	SPB630-04	4	630	637	4	3535	90	-	82	587	-	89	7	175	40,12
91307104	SPB710-04	4	710	717	4	3535	90	-	82	664	3,5	89	3,5	175	47,5
91308004	SPB800-04	4	800	807	4	4040	100	-	82	754	10	102	10	210	63,4
91309004	SPB900-04	4	900	907	4	4040	100	-	82	854	10	102	10	210	75
91310004	SPB1000-04	4	1000	1007	4	4040	100	-	82	954	10	102	10	210	86,15
91312504	SPB1250-04	4	1250	1257	4	4545	110	/	82	1204	16	114	16	242	116

MATERIAL CAST-IRON

CAD drawings available on our site
www.chiaravalli.com

Quantity, availability and prices
 on B2B Chiaravalli



TAPER BUSHES

SPB/05 TYPE

We are engaged to respect shapes and dimensions shown on this sheet but, we reserve the right to make changes and modifications without notice.

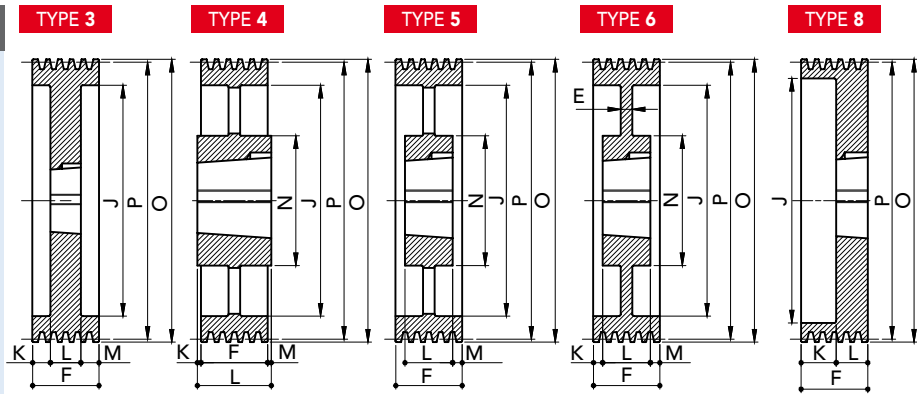

V-BELT PULLEYS for TAPER BUSHES

PRODUCT CODE	PRODUCT MODEL	GROOVES	P	O	TYPE	BUSH	MAX BORE	E	F	J	K	L	M	N	WEIGHT (Kg)
91301255	SPB125-05	5	125	132	8	2012	50	-	101	87	69	32	-	-	3,55
91301325	SPB132-05	5	132	139	8	2517	60	-	101	94	56	45	-	-	3,65
91301405	SPB140-05	5	140	147	3	2517	60	-	101	97	28	45	28	-	4,6
91301505	SPB150-05	5	150	157	3	2517	60	-	101	107	28	45	28	-	5,5
91301605	SPB160-05	5	160	167	3	2517	60	-	101	117	28	45	28	-	6,45
91301705	SPB170-05	5	170	177	3	3020	75	-	101	127	25	51	25	-	6,53
91301805	SPB180-05	5	180	187	3	3020	75	-	101	137	25	51	25	-	7,55
91301905	SPB190-05	5	190	197	3	3020	75	-	101	147	25	51	25	-	8,81
91302005	SPB200-05	5	200	207	3	3020	75	-	101	157	25	51	25	-	10,25
91302125	SPB212-05	5	212	219	3	3020	75	-	101	169	25	51	25	-	11,8
91302245	SPB224-05	5	224	231	3	3020	75	-	101	181	25	51	25	-	13,5
91302365	SPB236-05	5	236	243	3	3535	90	-	101	193	6	89	6	-	19,08
91302505	SPB250-05	5	250	257	3	3535	90	-	101	207	6	89	6	-	20,32
91302805	SPB280-05	5	280	287	6	3535	90	25	101	237	6	89	6	175	20,9
91303005	SPB300-05	5	300	307	5	3535	90	-	101	257	6	89	6	175	19,45
91303155	SPB315-05	5	315	322	5	3535	90	-	101	272	6	89	6	175	20,2
91303355	SPB335-05	5	335	342	5	3535	90	-	101	292	6	89	6	175	22,7
91303555	SPB355-05	5	355	362	5	3535	90	-	101	312	6	89	6	175	24,3
91304005	SPB400-05	5	400	407	5	3535	90	-	101	357	6	89	6	175	27,78
91304505	SPB450-05	5	450	457	5	3535	90	-	101	407	-	89	12	175	31,35
91305005	SPB500-05	5	500	507	5	3535	90	-	101	457	-	89	12	175	35,15
91305605	SPB560-05	5	560	567	4	4040	100	-	101	517	-	102	1	210	45,3
91306305	SPB630-05	5	630	637	4	4040	100	-	101	587	-	102	1	210	50,15
91307105	SPB710-05	5	710	717	4	4040	100	-	101	664	-	102	1	210	60,2
91308005	SPB800-05	5	800	807	4	4040	100	-	101	754	-	102	1	210	68
91310005	SPB1000-05	5	1000	1007	4	4545	110	-	101	954	6,5	114	6,5	242	99,75
91312505	SPB1250-05	5	1250	1257	4	4545	110	-	101	1204	6,5	114	6,5	242	133,2

MATERIAL **CAST-IRON**

CAD drawings available on our site
www.chiaravalli.com

Quantity, availability and prices
 on B2B Chiaravalli



TAPER BUSHES

SPB/06 TYPE

We are engaged to respect shapes and dimensions shown on this sheet but, we reserve the right to make changes and modifications without notice.

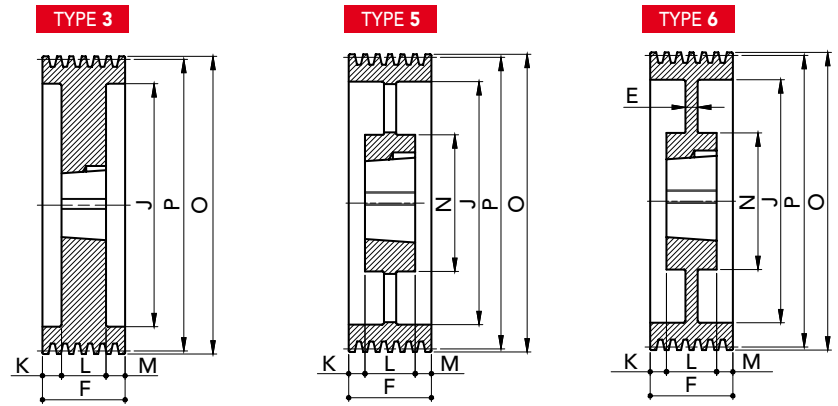

PRODUCT CODE	PRODUCT MODEL	GROOVES	P	O	TYPE	BUSH	MAX BORE	E	F	J	K	L	M	N	WEIGHT (Kg)
91301406	SPB140-06	6	140	147	3	2517	60	-	120	100	37,5	45	37,5	-	5,1
91301506	SPB150-06	6	150	157	3	2517	60	-	120	107	37,5	45	37,5	-	6,25
91301606	SPB160-06	6	160	167	3	3020	75	-	120	119	34,5	51	34,5	-	6,18
91301706	SPB170-06	6	170	177	3	3020	75	-	120	127	34,5	51	34,5	-	7,35
91301806	SPB180-06	6	180	187	3	3020	75	-	120	137	34,5	51	34,5	-	8,57
91301906	SPB190-06	6	190	197	3	3020	75	-	120	147	34,5	51	34,5	-	9,75
91302006	SPB200-06	6	200	207	3	3020	75	-	120	157	34,5	51	34,5	-	11,46
91302126	SPB212-06	6	212	219	3	3535	90	-	120	169	15,5	89	15,5	-	14,95
91302246	SPB224-06	6	224	231	3	3535	90	-	120	181	15,5	89	15,5	-	17,57
91302366	SPB236-06	6	236	243	3	3535	90	-	120	193	15,5	89	15,5	-	20,25
91302506	SPB250-06	6	250	257	3	3535	90	-	120	207	15,5	89	15,5	-	23,74
91302806	SPB280-06	6	280	287	6	3535	90	25	120	237	15,5	89	15,5	175	22,52
91303006	SPB300-06	6	300	307	5	3535	90	-	120	257	15,5	89	15,5	175	22,35
91303156	SPB315-06	6	315	322	5	3535	90	-	120	272	15,5	89	15,5	175	23,55
91303356	SPB335-06	6	335	342	5	3535	90	-	120	292	15,5	89	15,5	175	25,05
91303556	SPB355-06	6	355	362	5	3535	90	-	120	312	15,5	89	15,5	175	26,08
91304006	SPB400-06	6	400	407	5	3535	90	-	120	357	15,5	89	15,5	175	29,85
91304506	SPB450-06	6	450	457	5	4040	100	-	120	407	/	102	18	210	39,3
91305006	SPB500-06	6	500	507	5	4040	100	-	120	457	/	102	18	210	43,43
91305606	SPB560-06	6	560	567	5	4040	100	-	120	517	/	102	18	210	48,55
91306306	SPB630-06	6	630	637	5	4040	100	-	120	587	/	102	18	210	54,7
91307106	SPB710-06	6	710	717	5	4040	100	-	120	664	9	102	9	210	65,98
91308006	SPB800-06	6	800	807	5	4545	110	-	120	754	3	114	3	242	77,52
91310006	SPB1000-06	6	1000	1007	5	4545	110	-	120	954	3	114	3	242	111
91312506	SPB1250-06	6	1250	1257	5	4545	110	-	120	1204	3	114	3	242	144

MATERIAL CAST-IRON

CAD drawings available on our site
www.chiaravalli.com

Quantity, availability and prices
 on B2B Chiaravalli



V-BELT PULLEYS for TAPER BUSHES

TAPER BUSHES

SPB/08 TYPE

We are engaged to respect shapes and dimensions shown on this sheet but, we reserve the right to make changes and modifications without notice.

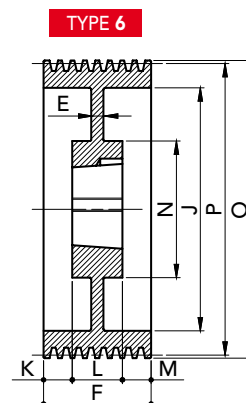
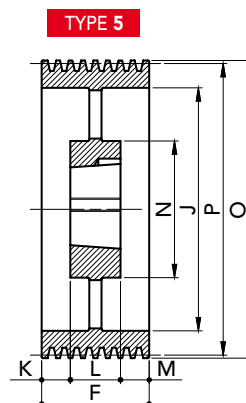
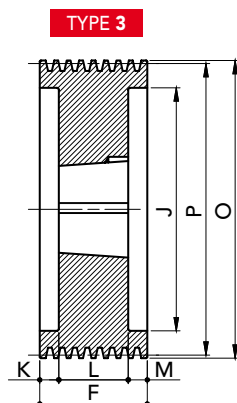

V-BELT PULLEYS for TAPER BUSHES

PRODUCT CODE	PRODUCT MODEL	GROOVES	P	O	TYPE	BUSH	MAX BORE	E	F	J	K	L	M	N	WEIGHT (Kg)
91301408	SPB140-08	6	140	147	3	2517	60	-	158	97	56,5	45	56,5	-	6,78
91301608	SPB160-08	6	160	167	3	3020	60	-	158	118	53,5	51	53,5	-	7,85
91301808	SPB180-08	8	180	187	3	3030	75	-	158	137	41	76	41	-	12
91301908	SPB190-08	8	190	197	3	3030	75	-	158	147	41	76	41	-	13,55
91302008	SPB200-08	8	200	207	3	3535	75	-	158	157	34,5	89	34,5	-	14,6
91302128	SPB212-08	8	212	219	3	3535	75	-	158	169	34,5	89	34,5	-	17,02
91302248	SPB224-08	8	224	231	3	3535	75	-	158	181	34,5	89	34,5	-	20,16
91302368	SPB236-08	8	236	243	3	3535	90	-	158	193	34,5	89	34,5	-	22,9
91302508	SPB250-08	8	250	257	3	3535	90	-	158	207	34,5	89	34,5	-	26,69
91302808	SPB280-08	8	280	287	6	3535	90	25	158	237	34,5	89	34,5	175	25,87
91303008	SPB300-08	8	300	307	6	3535	90	25	158	257	34,5	89	34,5	175	28,55
91303158	SPB315-08	8	315	322	5	3535	90	-	158	272	34,5	89	34,5	175	28,35
91303358	SPB335-08	8	335	342	5	3535	90	-	158	292	34,5	89	34,5	175	31,1
91303558	SPB355-08	8	355	362	5	3535	90	-	158	312	34,5	89	34,5	175	31,4
91304008	SPB400-08	8	400	407	5	4040	100	-	158	357	28	102	28	210	41,5
91304508	SPB450-08	8	450	457	5	4040	100	-	158	407	28	102	28	210	46,75
91305008	SPB500-08	8	500	507	5	4040	100	-	158	457	28	102	28	210	52,35
91305608	SPB560-08	8	560	567	5	4545	110	-	158	517	22	114	22	242	65,7
91306308	SPB630-08	8	630	637	5	4545	110	-	158	587	22	114	22	242	72,06
91307108	SPB710-08	8	710	717	5	4545	110	-	158	664	22	114	22	242	83
91308008	SPB800-08	8	800	807	5	4545	110	-	158	754	22	114	22	242	97,56
91310008	SPB1000-08	8	1000	1007	5	5050	125	-	158	954	15,5	127	15,5	267	130
91312508	SPB1250-08	8	1250	1257	5	5050	125	-	158	1204	15,5	127	15,5	267	161,4

MATERIAL CAST-IRON

CAD drawings available on our site
www.chiaravalli.com

Quantity, availability and prices
 on B2B Chiaravalli



V-BELT PULLEYS for TAPER BUSHES

TAPER BUSHES

SPB/10 TYPE

We are engaged to respect shapes and dimensions shown on this sheet but, we reserve the right to make changes and modifications without notice.

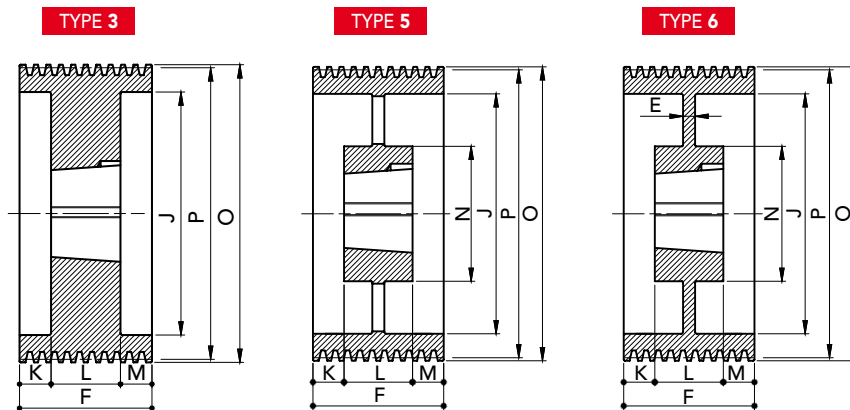

PRODUCT CODE	PRODUCT MODEL	GROOVES	P	O	TYPE	BUSH	MAX BORE	E	F	J	K	L	M	N	WEIGHT (Kg)
91302210	SPB224-10	10	224	231	3	3535	90	-	196	181	53,5	89	53,5	-	23,1
91303510	SPB355-10	10	355	362	5	4040	100	-	196	312	47	102	47	210	43
91307010	SPB710-10	10	710	717	5	4545	110	-	196	664	41	114	41	242	95,7
91308010	SPB800-10	10	800	807	5	4545	110	-	196	754	41	114	41	242	112
91310010	SPB1000-10	10	1000	1007	5	5050	125	-	196	954	34,5	127	34,5	267	150
91312510	SPB1250-10	10	1250	1257	5	5050	125	-	196	1204	34,5	127	34,5	267	201

MATERIAL **CAST-IRON**

CAD drawings available on our site
www.chiaravalli.com

Quantity, availability and prices
 on B2B Chiaravalli



TAPER BUSHES

SPC/02 TYPE

We are engaged to respect shapes and dimensions shown on this sheet but, we reserve the right to make changes and modifications without notice.

TYPE 2

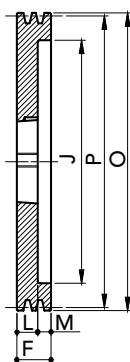

TYPE 5

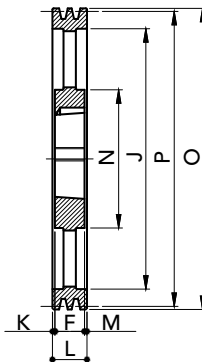

TYPE 4

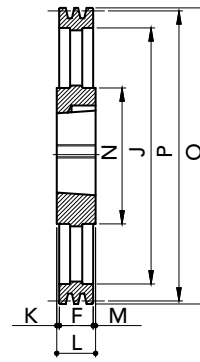

PRODUCT CODE	PRODUCT MODEL	GROOVES	P	O	TYPE	BUSH	MAX BORE	E	F	J	K	L	M	N	WEIGHT (Kg)
91402002	SPC200-02	2	200	209,6	2	2517	60	-	59,5	144	-	45	14,5	-	8,23
91402242	SPC224-02	2	224	233,6	2	3020	75	-	59,5	168	-	51	8,5	-	10,3
91402502	SPC250-02	2	250	259,6	2	3020	75	-	59,5	194	-	51	8,5	-	13,75
91402802	SPC280-02	2	280	289,6	2	3020	75	-	59,5	224	-	51	8,5	-	21,26
91403002	SPC300-02	2	300	309,6	5	3020	75	-	59,5	244	4,25	51	4,25	144	12,9
91403152	SPC315-02	2	315	324,6	5	3020	75	-	59,5	259	4,25	51	4,25	144	13,5
91403352	SPC335-02	2	335	344,6	5	3020	75	-	59,5	279	4,25	51	4,25	144	15,42
91403552	SPC355-02	2	355	364,6	4	3535	90	-	59,5	299	14,75	89	14,75	175	23,00
91404002	SPC400-02	2	400	409,6	4	3535	90	-	59,5	344	14,75	89	14,75	175	25,00
91404502	SPC450-02	2	450	459,6	4	3535	90	-	59,5	394	14,75	89	14,75	175	27,00

V-BELT PULLEYS for TAPER BUSHES

MATERIAL **CAST-IRON**

CAD drawings available on our site
www.chiaravalli.com

Quantity, availability and prices
 on B2B Chiaravalli



TAPER BUSHES

SPC/03 TYPE

We are engaged to respect shapes and dimensions shown on this sheet but, we reserve the right to make changes and modifications without notice.

TYPE 1

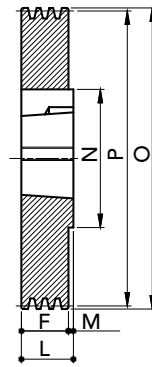

TYPE 3

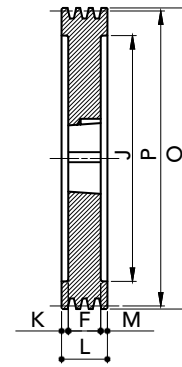

TYPE 4

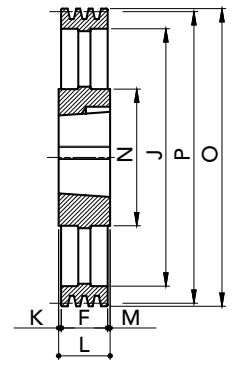

PRODUCT CODE	PRODUCT MODEL	GROOVES	P	O	TYPE	BUSH	MAX BORE	E	F	J	K	L	M	N	WEIGHT (Kg)
91401803	SPC180-03	3	180	189,6	3	2517	60	-	85	124	20	45	20	-	7,94
91402003	SPC200-03	3	200	209,6	3	2517	60	-	85	144	20	45	20	-	10,06
91402243	SPC224-03	3	224	233,6	3	3020	75	-	85	168	17	51	17	-	12,35
91402503	SPC250-03	3	250	259,6	3	3020	75	-	85	194	17	51	17	-	16,15
91402803	SPC280-03	3	280	289,6	1	3535	90	-	85	-	-	89	4	175	27,05
91403003	SPC300-03	3	300	309,6	4	3535	90	-	85	244	2	89	2	175	20,63
91403153	SPC315-03	3	315	324,6	4	3535	90	-	85	259	2	89	2	175	21,91
91403353	SPC335-03	3	335	344,6	4	3535	90	-	85	279	2	89	2	175	23,65
91403553	SPC355-03	3	355	364,6	4	3535	90	-	85	299	2	89	2	175	24,2
91404003	SPC400-03	3	400	409,6	4	3535	90	-	85	344	2	89	2	175	27,63
91404503	SPC450-03	3	450	459,6	4	3535	90	-	85	394	2	89	2	175	31,6
91405003	SPC500-03	3	500	509,6	4	3535	90	-	85	444	2	89	2	175	36,3
91405603	SPC560-03	3	560	569,6	4	3535	90	-	85	504	2	89	2	175	40,12
91406303	SPC630-03	3	630	639,6	4	4040	100	-	85	574	8,5	102	8,5	210	51,45
91408003	SPC800-03	3	800	809,6	4	4545	110	-	85	737	14,5	114	14,5	242	79
91410003	SPC1000-03	3	1000	1009,6	4	5050	125	-	85	937	21	127	21	267	120,5
91412503	SPC1250-03	3	1250	1259,6	4	5050	125	-	85	1187	21	127	21	267	136

MATERIAL CAST-IRON

CAD drawings available on our site
www.chiaravalli.com

Quantity, availability and prices
 on B2B Chiaravalli



TAPER BUSHES

SPC/04 TYPE

We are engaged to respect shapes and dimensions shown on this sheet but, we reserve the right to make changes and modifications without notice.

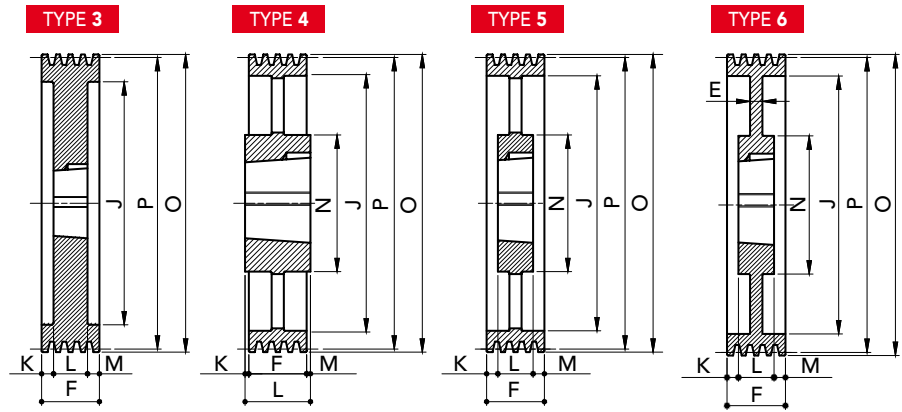

PRODUCT CODE	PRODUCT MODEL	GROOVES	P	O	TYPE	BUSH	MAX BORE	E	F	J	K	L	M	N	WEIGHT (Kg)
91401804	SPC180-04	4	180	189,6	3	3020	75	-	111	124	30	51	30	-	8,65
91402004	SPC200-04	4	200	209,6	3	3020	75	-	111	144	30	51	30	-	11,15
91402244	SPC224-04	4	224	233,6	3	3535	90	-	111	168	11	89	11	-	16,3
91402504	SPC250-04	4	250	259,6	3	3535	90	-	111	194	11	89	11	-	22
91402804	SPC280-04	4	280	289,6	6	3535	90	18	111	224	11	89	11	175	22,51
91403004	SPC300-04	4	300	309,6	6	3535	90	20	111	244	11	89	11	175	24,6
91403154	SPC315-04	4	315	324,6	5	3535	90	-	111	259	11	89	11	175	24,73
91403354	SPC335-04	4	335	344,6	5	3535	90	-	111	279	11	89	11	175	27,45
91403554	SPC355-04	4	355	364,6	5	3535	90	-	111	299	11	89	11	175	29,5
91404004	SPC400-04	4	400	409,6	5	3535	90	-	111	344	11	89	11	175	33,27
91404504	SPC450-04	4	450	459,6	5	3535	90	-	111	394	11	89	11	175	36,8
91405004	SPC500-04	4	500	509,6	5	3535	90	-	111	444	11	89	11	175	42,6
91405604	SPC560-04	4	560	569,6	5	4040	100	-	111	504	4,5	102	4,5	210	53,15
91406304	SPC630-04	4	630	639,6	4	4545	110	-	111	574	1,5	114	1,5	242	68,2
91407104	SPC710-04	4	710	719,6	4	5050	125	-	111	654	8	127	8	267	86,16
91408004	SPC800-04	4	800	809,6	4	5050	125	-	111	737	8	127	8	267	97,15
91410004	SPC1000-04	4	1000	1009,6	4	5050	125	-	111	937	8	127	8	267	125
91412504	SPC1250-04	4	1250	1259,6	4	5050	125	-	111	1187	8	127	8	267	166

V-BELT PULLEYS for TAPER BUSHES

MATERIAL **CAST-IRON**

CAD drawings available on our site
www.chiaravalli.com

Quantity, availability and prices
 on B2B Chiaravalli

TAPER BUSHES
SPC/05 TYPE

We are engaged to respect shapes and dimensions shown on this sheet but, we reserve the right to make changes and modifications without notice.

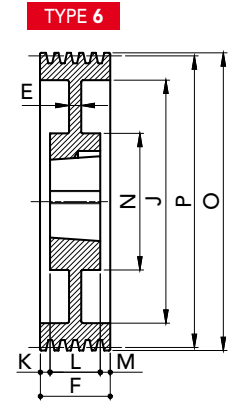
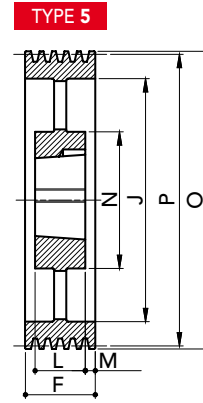
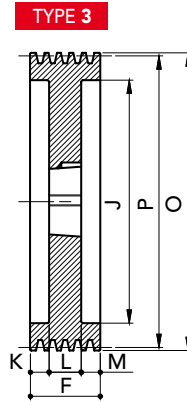

PRODUCT CODE	PRODUCT MODEL	GROOVES	P	O	TYPE	BUSH	MAX BORE	E	F	J	K	L	M	N	WEIGHT (Kg)
91401805	SPC180-05	5	180	189,6	3	3020	75	-	136	124	42,5	51	42,5	-	9,2
91402005	SPC200-05	5	200	209,6	3	3535	90	-	136	144	23,5	89	23,5	-	13,07
91402245	SPC224-05	5	224	233,6	3	3535	90	-	136	168	23,5	89	23,5	-	18,3
91402505	SPC250-05	5	250	259,6	3	3535	90	-	136	194	23,5	89	23,5	-	24,55
91402805	SPC280-05	5	280	289,6	3	3535	90	-	136	224	23,5	89	23,5	-	32,81
91403005	SPC300-05	5	300	309,6	6	3535	90	20	136	244	23,5	89	23,5	175	29,8
91403155	SPC315-05	5	315	324,6	5	3535	90	-	136	259	23,5	89	23,5	210	28,21
91403355	SPC335-05	5	335	344,6	5	3535	90	-	136	279	23,5	89	23,5	210	30,7
91403555	SPC355-05	5	355	364,6	5	3535	90	-	136	299	23,5	89	23,5	242	33,12
91404005	SPC400-05	5	400	409,6	5	3535	90	-	136	344	23,5	89	23,5	267	37,4
91404505	SPC450-05	5	450	459,6	5	4040	100	-	136	394	17	102	17	267	48,1
91405005	SPC500-05	5	500	509,6	5	4040	100	-	136	444	17	102	17	267	54
91405605	SPC560-05	5	560	569,6	5	4545	110	-	136	504	11	114	11	267	66,77
91406305	SPC630-05	5	630	639,6	5	5050	125	-	136	574	4,5	127	4,5	267	82
91407105	SPC710-05	5	710	719,6	5	5050	125	-	136	654	4,5	127	4,5	267	93,2
91408005	SPC800-05	5	800	809,6	5	5050	125	-	136	737	4,5	127	4,5	267	110
91410005	SPC1000-05	5	1000	1009,6	5	5050	125	-	136	937	4,5	127	4,5	267	154
91412505	SPC1250-05	5	1250	1259,6	5	5050	125	-	136	1187	4,5	127	4,5	267	188

 MATERIAL **CAST-IRON**

 CAD drawings available on our site
www.chiaravalli.com

 Quantity, availability and prices
 on B2B Chiaravalli



TAPER BUSHES

SPC/06 TYPE

We are engaged to respect shapes and dimensions shown on this sheet but, we reserve the right to make changes and modifications without notice.

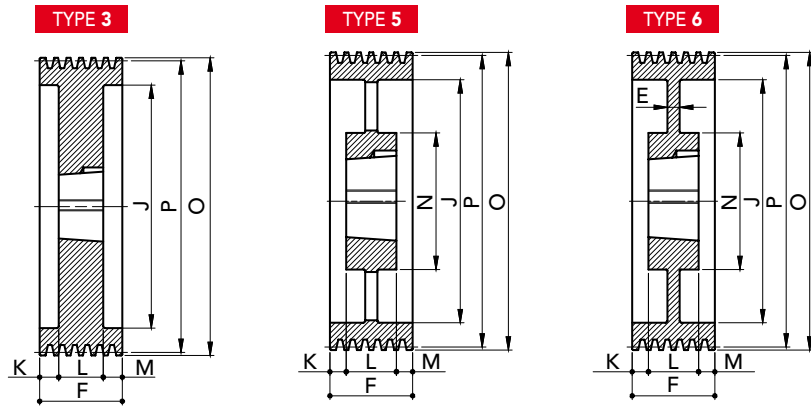

PRODUCT CODE	PRODUCT MODEL	GROOVES	P	O	TYPE	BUSH	MAX BORE	E	F	J	K	L	M	N	WEIGHT (Kg)
91401806	SPC180-06	6	180	189,6	3	3020	75	-	162	124	55,5	51	55,5	-	11,88
91402006	SPC200-06	6	200	209,6	3	3535	90	-	162	144	36,5	89	36,5	-	14,8
91402246	SPC224-06	6	224	233,6	3	3535	90	-	162	168	36,5	89	36,5	-	20,3
91402366	SPC236-06	6	236	245,6	3	3535	90	-	162	180	36,5	89	36,5	-	23,31
91402506	SPC250-06	6	250	259,6	3	3535	90	-	162	194	36,5	89	36,5	-	27,17
91402806	SPC280-06	6	280	289,6	6	3535	90	20	162	224	36,5	89	36,5	175	28,9
91403006	SPC300-06	6	300	309,6	6	3535	90	20	162	244	36,5	89	36,5	175	30,35
91403156	SPC315-06	6	315	324,6	5	3535	90	-	162	259	36,5	89	36,5	175	31,35
91403356	SPC335-06	6	335	344,6	5	3535	90	-	162	279	36,5	89	36,5	175	35
91403556	SPC355-06	6	355	364,6	5	3535	90	-	162	299	36,5	89	36,5	175	37,1
91404006	SPC400-06	6	400	409,6	5	4040	100	-	162	344	30	102	30	210	47,76
91404506	SPC450-06	6	450	459,6	5	4545	110	-	162	394	24	114	24	242	60,98
91405006	SPC500-06	6	500	509,6	5	4545	110	-	162	444	24	114	24	242	67,6
91405606	SPC560-06	6	560	569,6	5	5050	125	-	162	504	17,5	127	17,5	267	81,4
91406306	SPC630-06	6	630	639,6	5	5050	125	-	162	574	17,5	127	17,5	267	89,7
91407106	SPC710-06	6	710	719,6	5	5050	125	-	162	654	17,5	127	17,5	267	102,6
91408006	SPC800-06	6	800	809,6	5	5050	125	-	162	737	17,5	127	17,5	267	123,6
91410006	SPC1000-06	6	1000	1009,6	5	5050	125	-	162	937	17,5	127	17,5	267	160
91412506	SPC1250-06	6	1250	1259,6	5	5050	125	-	162	1187	17,5	127	17,5	267	201

V-BELT PULLEYS for TAPER BUSHES

MATERIAL **CAST-IRON**

CAD drawings available on our site
www.chiaravalli.com

Quantity, availability and prices
 on B2B Chiaravalli



TAPER BUSHES

SPC/08 TYPE

We are engaged to respect shapes and dimensions shown on this sheet but, we reserve the right to make changes and modifications without notice.

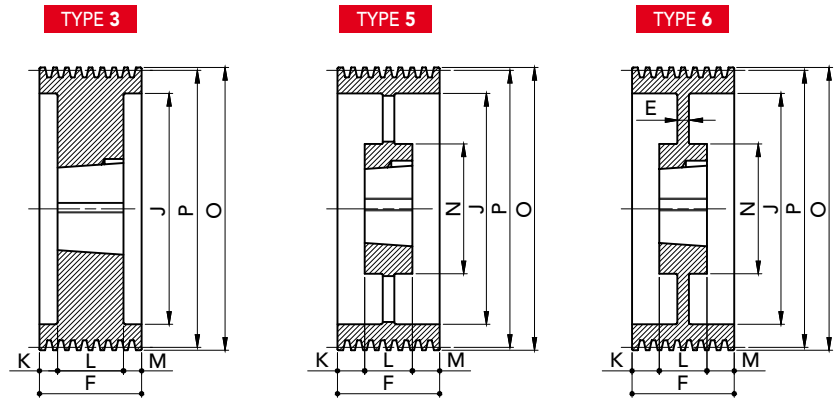

PRODUCT CODE	PRODUCT MODEL	GROOVES	P	O	TYPE	BUSH	MAX BORE	E	F	J	K	L	M	N	WEIGHT (Kg)
91402008	SPC200-08	8	200	209,6	3	3535	90	-	213	144	62	89	62	-	18,52
91402248	SPC224-08	8	224	233,6	3	3535	90	-	213	168	62	89	62	-	24,85
91402508	SPC250-08	8	250	259,6	3	3535	90	-	213	194	62	89	62	-	31,9
91402808	SPC280-08	8	280	289,6	3	3535	90	-	213	224	62	89	62	-	40,6
91403008	SPC300-08	8	300	309,6	3	4040	100	-	213	244	55,5	102	55,5	-	47,71
91403158	SPC315-08	8	315	324,6	3	4040	100	-	213	259	55,5	102	55,5	-	53,92
91403358	SPC335-08	8	335	344,6	6	4040	100	50	213	279	55,5	102	55,5	210	53
91403558	SPC355-08	8	355	364,6	5	4040	100	-	213	299	55,5	102	55,5	210	50,67
91404008	SPC400-08	8	400	409,6	5	4545	110	-	213	344	49,5	114	49,5	242	65,1
91404508	SPC450-08	8	450	459,6	5	5050	125	-	213	394	43	127	43	267	77,33
91405008	SPC500-08	8	500	509,6	5	5050	125	-	213	444	43	127	43	267	88,7
91405608	SPC560-08	8	560	569,6	5	5050	125	-	213	504	43	127	43	267	95,8
91406308	SPC630-08	8	630	639,6	5	5050	125	-	213	574	43	127	43	267	106
91407108	SPC710-08	8	710	719,6	5	5050	125	-	213	654	43	127	43	267	124
91408008	SPC800-08	8	800	809,6	5	5050	125	-	213	737	43	127	43	267	150
91410008	SPC1000-08	8	1000	1009,6	5	5050	125	-	213	937	43	127	43	267	191
91412508	SPC1250-08	8	1250	1259,6	5	5050	125	-	213	1187	43	127	43	267	255

MATERIAL **CAST-IRON**

CAD drawings available on our site
www.chiaravalli.com

Quantity, availability and prices
 on B2B Chiaravalli



TAPER BUSHES

SPC/10 TYPE

We are engaged to respect shapes and dimensions shown on this sheet but, we reserve the right to make changes and modifications without notice.

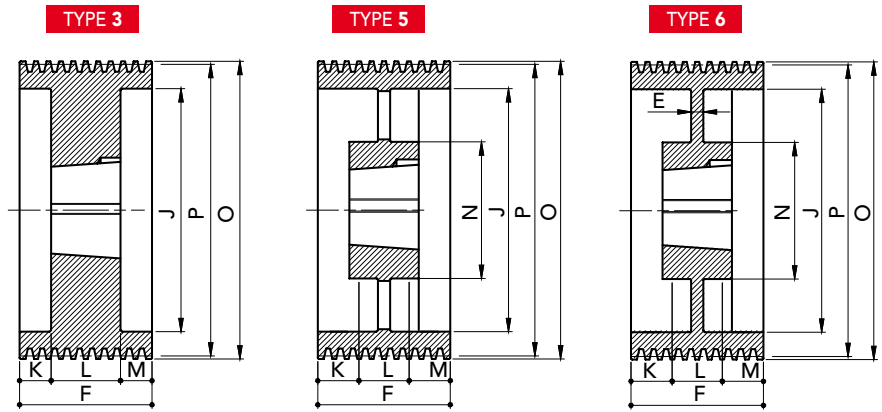

PRODUCT CODE	PRODUCT MODEL	GROOVES	P	O	TYPE	BUSH	MAX BORE	E	F	J	K	L	M	N	WEIGHT (Kg)
91402210	SPC224-10	10	224	233,6	3	4040	100	-	264	168	81	102	81	-	27
91402510	SPC250-10	10	250	259,6	3	4040	100	-	264	194	81	102	81	-	35,35
91402810	SPC280-10	10	280	289,6	3	4040	100	-	264	224	81	102	81	-	45,92
91403010	SPC300-10	10	300	309,6	3	4545	110	-	264	244	75	114	75	-	54
91403110	SPC315-10	10	315	324,6	3	4545	110	-	264	259	75	114	75	-	59,7
91403310	SPC335-10	10	335	344,6	3	4545	110	-	264	279	75	114	75	-	71
91403510	SPC355-10	10	355	364,6	3	4545	110	-	264	299	75	114	75	-	80,5
91404010	SPC400-10	10	400	409,6	6	5050	125	70	264	344	68,5	127	68,5	267	92
91404510	SPC450-10	10	450	459,6	5	5050	125	-	264	394	68,5	127	68,5	267	89,4
91405010	SPC500-10	10	500	509,6	5	5050	125	-	264	444	68,5	127	68,5	267	100
91405610	SPC560-10	10	560	569,6	5	5050	125	-	264	504	68,5	127	68,5	267	114
91406310	SPC630-10	10	630	639,6	5	5050	125	-	264	574	68,5	127	68,5	267	128
91407110	SPC710-10	10	710	719,6	5	5050	125	-	264	654	68,5	127	68,5	267	148
91408010	SPC800-10	10	800	809,6	5	5050	125	-	264	737	68,5	127	68,5	267	174
91410010	SPC1000-10	10	1000	1009,6	5	5050	125	-	264	937	68,5	127	68,5	267	222
91412510	SPC1250-10	10	1250	1259,6	5	5050	125	-	264	1187	68,5	127	68,5	267	311

V-BELT PULLEYS for TAPER BUSHES

MATERIAL **CAST-IRON**

CAD drawings available on our site
www.chiaravalli.com

Quantity, availability and prices
 on B2B Chiaravalli



CAST IRON V-BELT PULLEYS





SOLID HUB

SPA/1 TYPE

TYPE 1

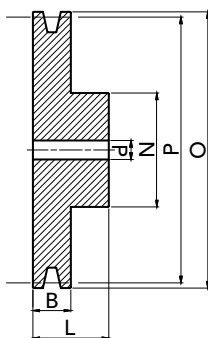

TYPE 3

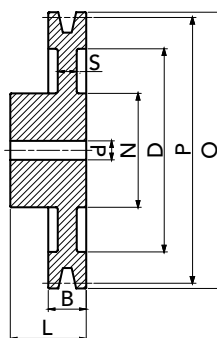

TYPE 5

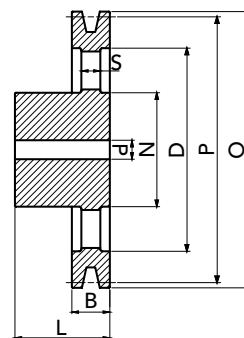

V-PULLEYS PILOT BORE

PRODUCT CODE	PRODUCT MODEL	P	O	GROOVES	N	L	D	S	B	TYPE	d (H9)	WEIGHT (Kg)
91220401	SPA40-1	40	45,5	1	40	35	-	-	20	1	10	0,26
91220501	SPA50-1	50	55,5	1	40	35	-	-	20	1	10	0,35
91220551	SPA55-1	55	60,5	1	40	35	-	-	20	1	10	0,41
91220601	SPA60-1	60	65,5	1	40	35	-	-	20	1	10	0,46
91220631	SPA63-1	63	68,5	1	40	35	-	-	20	1	10	0,49
91220651	SPA65-1	65	70,5	1	40	40	-	-	20	1	10	0,55
91220701	SPA70-1	70	75,5	1	40	40	-	-	20	1	10	0,68
91220751	SPA75-1	75	80,5	1	40	40	-	-	20	1	10	0,7
91220801	SPA80-1	80	85,5	1	45	40	-	-	20	1	10	0,84
91220851	SPA85-1	85	90,5	1	45	40	-	-	20	1	10	0,92
91220901	SPA90-1	90	95,5	1	45	40	-	-	20	1	10	1,02
91220951	SPA95-1	95	100,5	1	45	40	-	-	20	1	10	1,11
91221001	SPA100-1	100	105,5	1	48	40	-	-	20	1	10	1,25
91221051	SPA105-1	105	110,5	1	48	40	-	-	20	1	10	1,37
91221121	SPA112-1	112	117,5	1	48	40	-	-	20	1	10	1,55
91221201	SPA120-1	120	125,5	1	60	40	-	-	20	1	15	1,86
91221251	SPA125-1	125	130,5	1	60	40	-	-	20	1	15	2,06
91221301	SPA130-1	130	135,5	1	60	40	-	-	20	1	15	2,12
91221401	SPA140-1	140	145,5	1	60	40	107	10	20	3	15	1,98
91221501	SPA150-1	150	155,5	1	60	40	117	10	20	3	15	2,18
91221601	SPA160-1	160	165,5	1	60	40	127	10	20	3	15	2,36
91221701	SPA170-1	170	175,5	1	60	40	137	10	20	3	15	2,57
91221801	SPA180-1	180	185,5	1	65	40	147	10	20	3	20	2,85
91222001	SPA200-1	200	205,5	1	65	45	167	10	20	3	20	3,45
91222251	SPA225-1	225	230,5	1	65	45	193	10	20	3	20	4,07
91222501	SPA250-1	250	255,5	1	75	50	217	12	20	3	20	5,69
91222801	SPA280-1	280	285,5	1	75	50	247	14	20	5	20	4,46
91223001	SPA300-1	300	305,5	1	75	50	267	14	20	5	20	4,99
91223551	SPA355-1	355	360,5	1	75	50	322	14	20	5	20	6,5
91224001	SPA400-1	400	405,5	1	90	50	367	14	20	5	20	8,5
91224501	SPA450-1	450	455,5	1	90	50	417	14	20	5	20	9,4
91225001	SPA500-1	500	505,5	1	90	50	467	14	20	5	20	10,5
91225601	SPA560-1	560	565,5	1	100	50	527	15	20	5	25	12,7
91226001	SPA600-1	600	605,5	1	100	50	567	16	20	5	25	14,35

MATERIAL **CAST-IRON**

CAD drawings available on our site
www.chiaravalli.com

Quantity, availability and prices
 on B2B Chiaravalli



SOLID HUB

SPA/2 TYPE

TYPE 1

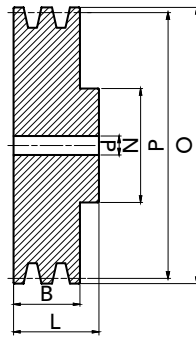

TYPE 3

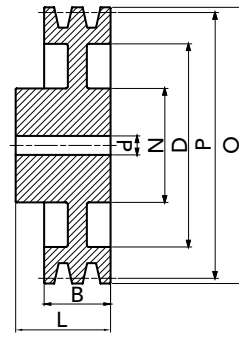

TYPE 5

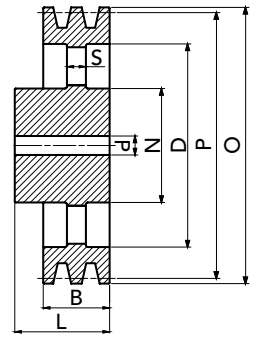

PRODUCT CODE	PRODUCT MODEL	P	O	GROOVES	N	L	D	S	B	TYPE	d (H9)	WEIGHT (Kg)
91220502	SPA50-2	50	55,5	2	40	45	-	-	35	1	10	0,44
91220552	SPA55-2	55	60,5	2	40	45	-	-	35	1	10	0,55
91220602	SPA60-2	60	65,5	2	40	45	-	-	35	1	10	0,60
91220632	SPA63-2	63	68,5	2	40	45	-	-	35	1	10	0,68
91220652	SPA65-2	65	70,5	2	40	45	-	-	35	1	10	0,74
91220702	SPA70-2	70	75,5	2	50	45	-	-	35	1	10	0,91
91220752	SPA75-2	75	80,5	2	50	45	-	-	35	1	10	1,05
91220802	SPA80-2	80	85,5	2	50	45	-	-	35	1	10	1,17
91220852	SPA85-2	85	90,5	2	50	45	-	-	35	1	10	1,32
91220902	SPA90-2	90	95,5	2	60	45	-	-	35	1	15	1,50
91220952	SPA95-2	95	100,5	2	60	45	-	-	35	1	15	1,67
91221002	SPA100-2	100	105,5	2	60	45	-	-	35	1	15	1,84
91221052	SPA105-2	105	110,5	2	60	45	-	-	35	1	15	2,07
91221122	SPA112-2	112	117,5	2	60	45	-	-	35	1	15	2,30
91221202	SPA120-2	120	125,5	2	60	45	-	-	35	1	15	2,68
91221252	SPA125-2	125	130,5	2	60	45	-	-	35	1	15	2,94
91221302	SPA130-2	130	135,5	2	60	45	-	-	35	1	15	3,25
91221402	SPA140-2	140	145,5	2	60	45	107	10	35	3	15	2,57
91221502	SPA150-2	150	155,5	2	60	45	117	10	35	3	15	2,80
91221602	SPA160-2	160	165,5	2	60	45	127	10	35	3	15	3,02
91221702	SPA170-2	170	175,5	2	60	45	137	10	35	3	20	3,30
91221802	SPA180-2	180	185,5	2	70	50	147	12	35	3	20	4,07
91221902	SPA190-2	190	195,5	2	70	50	157	12	35	3	20	4,40
91222002	SPA200-2	200	205,5	2	70	50	167	12	35	3	20	4,74
91222252	SPA225-2	225	230,5	2	70	50	193	12	35	3	20	5,54
91222502	SPA250-2	250	255,5	2	75	50	217	12	35	3	20	6,60
91222802	SPA280-2	280	285,5	2	80	50	247	14	35	5	20	5,92
91223002	SPA300-2	300	305,5	2	80	50	267	14	35	5	20	6,48
91223152	SPA315-2	315	320,5	2	80	50	282	14	35	5	20	6,94
91223552	SPA355-2	355	360,5	2	80	50	322	14	35	5	20	8,30
91224002	SPA400-2	400	405,5	2	90	50	367	14	35	5	20	10,5
91224502	SPA450-2	450	455,5	2	100	50	417	14	35	5	25	12
91225002	SPA500-2	500	505,5	2	100	50	467	16	35	5	25	14
91225602	SPA560-2	560	565,5	2	100	50	527	18	35	5	25	16
91226302	SPA630-2	630	635,5	2	110	50	597	18	35	5	25	21

MATERIAL **CAST-IRON**CAD drawings available on our site
www.chiaravalli.comQuantity, availability and prices
on B2B Chiaravalli



SOLID HUB

SPA/3 TYPE

TYPE 3

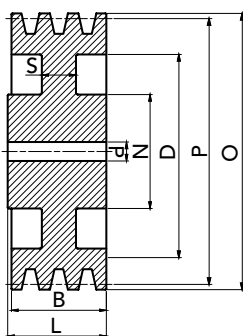

TYPE 5

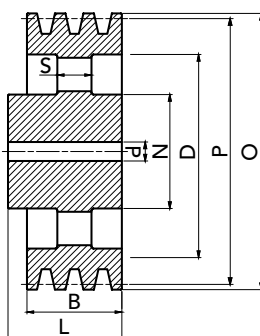

TYPE 7

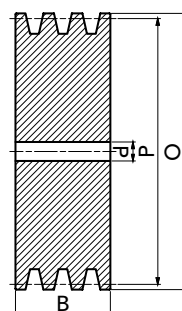

V-PULLEYS PILOT BORE

PRODUCT CODE	PRODUCT MODEL	P	O	GROOVES	N	L	D	S	B	TYPE	d (H9)	WEIGHT (Kg)
91220603	SPA60-3	60	65,5	3	-	-	-	-	50	7	10	0,75
91220633	SPA63-3	63	68,5	3	-	-	-	-	50	7	10	0,84
91220653	SPA65-3	65	70,5	3	-	-	-	-	50	7	10	0,91
91220703	SPA70-3	70	75,5	3	-	-	-	-	50	7	10	1,08
91220753	SPA75-3	75	80,5	3	-	-	-	-	50	7	10	1,24
91220803	SPA80-3	80	85,5	3	-	-	-	-	50	7	15	1,41
91220853	SPA85-3	85	90,5	3	-	-	-	-	50	7	15	1,62
91220903	SPA90-3	90	95,5	3	-	-	-	-	50	7	15	1,84
91220953	SPA95-3	95	100,5	3	-	-	-	-	50	7	15	2,07
91221003	SPA100-3	100	105,5	3	-	-	-	-	50	7	15	2,32
91221053	SPA105-3	105	110,5	3	-	-	-	-	50	7	15	4,33
91221123	SPA112-3	112	117,5	3	-	-	-	-	50	7	15	3,02
91221203	SPA120-3	120	125,5	3	-	-	-	-	50	7	15	3,50
91221253	SPA125-3	125	130,5	3	-	-	-	-	50	7	15	3,88
91221303	SPA130-3	130	135,5	3	-	-	-	-	50	7	15	4,33
91221403	SPA140-3	140	145,5	3	65	52	107	18	50	3	20	3,60
91221503	SPA150-3	150	155,5	3	65	52	117	18	50	3	20	3,95
91221603	SPA160-3	160	165,5	3	70	52	127	18	50	3	20	4,45
91221703	SPA170-3	170	175,5	3	70	52	137	18	50	3	20	4,94
91221803	SPA180-3	180	185,5	3	70	52	147	12	50	3	20	4,72
91222003	SPA200-3	200	205,5	3	70	52	167	12	50	3	20	5,42
91222253	SPA225-3	225	230,5	3	80	52	193	12	50	3	20	6,72
91222503	SPA250-3	250	255,5	3	80	60	217	12	50	3	20	8,11
91222803	SPA280-3	280	285,5	3	80	60	247	14	50	5	20	7,30
91223003	SPA300-3	300	305,5	3	80	60	267	14	50	5	20	7,96
91223553	SPA355-3	355	360,5	3	90	60	322	14	50	5	20	11
91224003	SPA400-3	400	405,5	3	100	60	367	16	50	5	25	13
91224503	SPA450-3	450	455,5	3	100	60	417	16	50	5	25	15
91225003	SPA500-3	500	505,5	3	105	60	467	20	50	5	25	18,6
91225603	SPA560-3	560	565,5	3	120	65	527	20	50	5	25	23
91226303	SPA630-3	630	635,5	3	120	65	597	20	50	5	25	26,7

MATERIAL **CAST-IRON**

CAD drawings available on our site
www.chiaravalli.com

Quantity, availability and prices
 on B2B Chiaravalli



SOLID HUB

SPA/4 TYPE

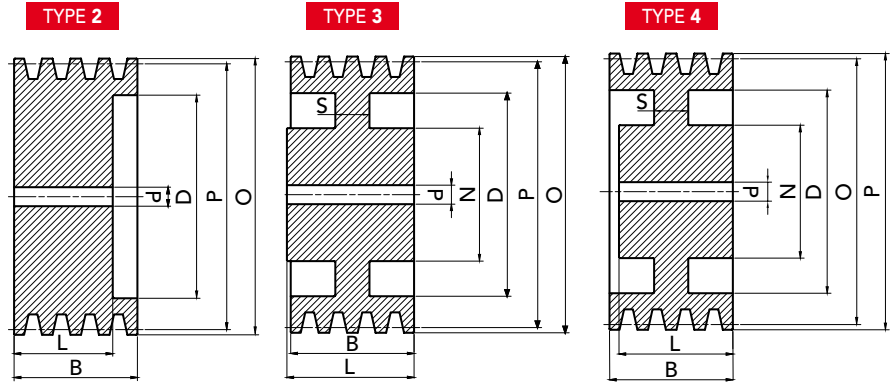

PRODUCT CODE	PRODUCT MODEL	P	O	GROOVES	N	L	D	S	B	TYPE	d (H9)	WEIGHT (Kg)
91220704	SPA70-4	70	75,5	4	-	-	-	-	65	7	10	1,42
91220754	SPA75-4	75	80,5	4	-	-	-	-	65	7	10	1,58
91220804	SPA80-4	80	85,5	4	-	-	-	-	65	7	15	1,81
91220854	SPA85-4	85	90,5	4	-	-	-	-	65	7	15	2,08
91220904	SPA90-4	90	95,5	4	-	-	-	-	65	7	15	2,38
91220954	SPA95-4	95	100,5	4	-	-	-	-	65	7	15	2,67
91221004	SPA100-4	100	105,5	4	-	52	67	-	65	2	15	2,67
91221054	SPA105-4	105	110,5	4	-	52	72	-	65	2	15	3,13
91221124	SPA112-4	112	117,5	4	-	52	79	-	65	2	15	3,60
91221204	SPA120-4	120	125,5	4	-	52	87	-	65	2	15	3,76
91221254	SPA125-4	125	130,5	4	-	52	97	-	65	2	15	4,29
91221304	SPA130-4	130	135,5	4	-	52	97	-	65	2	15	4,95
91221404	SPA140-4	140	145,5	4	-	52	107	-	65	2	20	5,50
91221504	SPA150-4	150	155,5	4	-	52	117	-	65	2	20	6,29
91221604	SPA160-4	160	165,5	4	70	52	127	18	65	4	20	5,33
91221704	SPA170-4	170	175,5	4	80	52	137	18	65	4	20	5,79
91221804	SPA180-4	180	185,5	4	80	60	147	18	65	4	20	6,93
91222004	SPA200-4	200	205,5	4	80	60	167	18	65	4	20	7,55
91222254	SPA225-4	225	230,5	4	90	60	192	18	65	4	20	9,10
91222504	SPA250-4	250	255,5	4	90	65	217	18	65	3	20	11,08
91222804	SPA280-4	280	285,5	3	90	65	247	16	65	5	20	9,55
91223004	SPA300-4	300	305,5	4	90	65	267	16	65	5	20	10,22
91223554	SPA355-4	355	360,5	4	90	65	322	16	65	5	25	12,67
91224004	SPA400-4	400	405,5	4	100	65	367	20	65	5	25	16,4
91224504	SPA450-4	450	455,5	4	105	65	417	20	65	6	25	17
91225004	SPA500-4	500	505,5	4	105	65	467	20	65	6	25	18
91225604	SPA560-4	560	565,5	4	120	65	527	22	65	5	25	26,5
91226304	SPA630-4	630	635,5	4	120	65	597	22	65	5	25	35

MATERIAL CAST-IRON

CAD drawings available on our site
www.chiaravalli.com

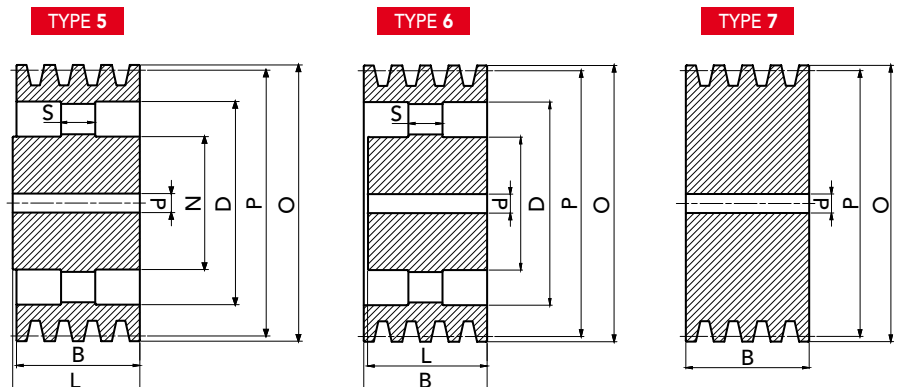

Quantity, availability and prices
 on B2B Chiaravalli



SOLID HUB

SPA/5 TYPE

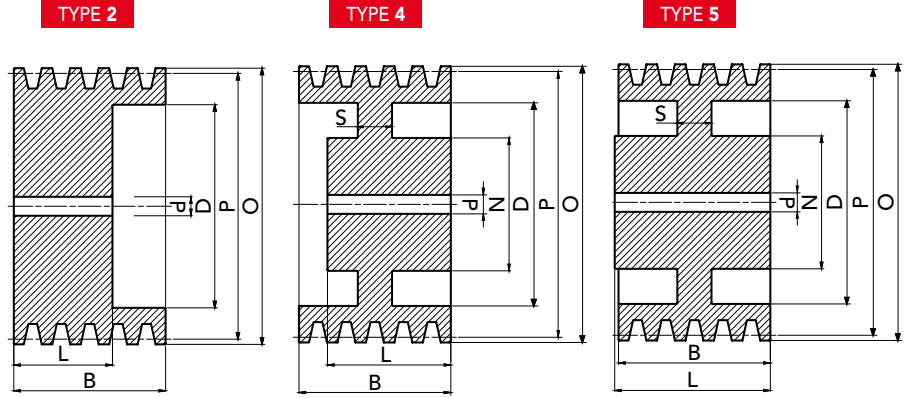

V-PULLEYS PILOT BORE

PRODUCT CODE	PRODUCT MODEL	P	O	GROOVES	N	L	D	S	B	TYPE	d (H9)	WEIGHT (Kg)
91220705	SPA70-5	70	75,5	5	-	-	-	-	80	7	10	1,70
91220755	SPA75-5	75	80,5	5	-	-	-	-	80	7	10	2,20
91220805	SPA80-5	80	85,5	5	-	-	-	-	80	7	15	2,23
91220855	SPA85-5	85	90,5	5	-	-	-	-	80	7	15	2,55
91220905	SPA90-5	90	95,5	5	-	-	-	-	80	7	15	2,91
91220955	SPA95-5	95	100,5	5	-	-	-	-	80	7	15	2,94
91221005	SPA100-5	100	105,5	5	-	52	67	-	80	2	15	2,97
91221055	SPA105-5	105	110,5	5	-	52	72	-	80	2	15	3,30
91221125	SPA112-5	112	117,5	5	-	52	79	-	80	2	15	3,77
91221205	SPA120-5	120	125,5	5	-	52	87	-	80	2	15	4,30
91221305	SPA130-5	130	135,5	5	-	52	97	-	80	2	15	5,45
91221405	SPA140-5	140	145,5	5	-	52	107	-	80	2	20	6,30
91221505	SPA150-5	150	155,5	5	-	52	117	-	80	2	20	6,84
91221605	SPA160-5	160	165,5	5	80	52	127	22	80	4	20	6,12
91221705	SPA170-5	170	175,5	5	80	52	137	18	80	4	20	6,80
91221805	SPA180-5	180	185,5	5	80	65	147	22	80	4	20	7,7
91222005	SPA200-5	200	205,5	5	80	65	167	20	80	4	20	8,72
91222255	SPA225-5	225	230,5	5	90	65	192	20	80	4	20	10,50
91222505	SPA250-5	250	255,5	5	90	65	217	20	80	4	20	11,5
91222805	SPA280-5	280	285,5	5	100	65	247	18	80	6	25	12
91223005	SPA300-5	300	305,5	5	100	65	267	18	80	6	25	12,24
91223555	SPA355-5	355	360,5	5	100	65	322	18	80	6	25	15,2
91224005	SPA400-5	400	405,5	5	100	65	367	22	80	6	25	18
91224505	SPA450-5	450	455,5	5	105	65	417	22	80	6	25	21,4
91225005	SPA500-5	500	505,5	5	110	65	467	22	80	6	25	24,6
91225605	SPA560-5	560	565,5	5	120	80	527	24	80	5	25	28
91226005	SPA600-5	600	605,5	5	120	80	567	26	80	5	25	32
91226305	SPA630-5	630	635,5	5	120	80	597	24	80	5	25	35

MATERIAL CAST-IRON

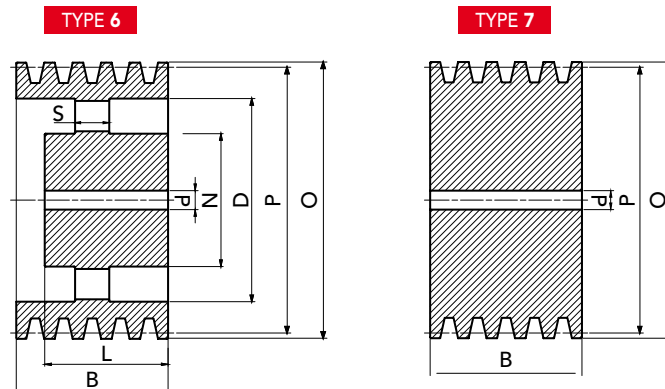

CAD drawings available on our site
www.chiaravalli.com

Quantity, availability and prices
on B2B Chiaravalli



SOLID HUB

SPB/1 TYPE

TYPE 1

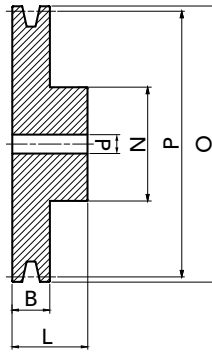

TYPE 3

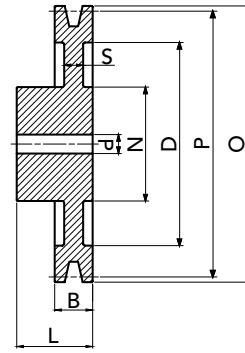

TYPE 5

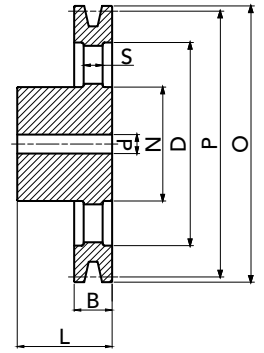

PRODUCT CODE	PRODUCT MODEL	P	O	GROOVES	N	L	D	S	B	TYPE	d (H9)	WEIGHT (Kg)
91320701	SPB70-1	70	77	1	45	45	-	-	25	1	10	0,77
91320801	SPB80-1	80	87	1	50	45	-	-	25	1	10	1,01
91320901	SPB90-1	90	97	1	50	45	-	-	25	1	10	1,24
91321001	SPB100-1	100	107	1	52	45	-	-	25	1	10	1,48
91321121	SPB112-1	112	119	1	55	45	-	-	25	1	15	1,83
91321201	SPB120-1	120	127	1	55	45	-	-	25	1	15	2,06
91321251	SPB125-1	125	132	1	58	45	-	-	25	1	15	2,26
91321301	SPB130-1	130	137	1	60	45	-	-	25	1	15	2,46
91321401	SPB140-1	140	147	1	65	45	-	-	25	1	20	2,84
91321501	SPB150-1	150	157	1	65	45	-	-	25	1	20	3,21
91321601	SPB160-1	160	167	1	65	45	118	12	25	3	20	2,93
91321701	SPB170-1	170	177	1	65	45	128	12	25	3	20	3,25
91321801	SPB180-1	180	187	1	65	45	138	12	25	3	20	3,48
91322001	SPB200-1	200	207	1	70	45	158	14	25	3	20	4,47
91322121	SPB212-1	212	219	1	70	45	170	14	25	3	20	4,89
91322251	SPB225-1	225	232	1	70	45	184	14	25	3	20	5,25
91322501	SPB250-1	250	257	1	70	50	208	14	25	3	20	6,52
91322801	SPB280-1	280	287	1	76	50	238	14	25	3	20	8,08
91323001	SPB300-1	300	307	1	76	50	258	15	25	5	20	5,98
91323151	SPB315-1	315	322	1	76	50	273	15	25	5	20	6,25
91323401	SPB340-1	340	347	1	80	50	298	15	25	5	20	6,70
91323551	SPB355-1	355	362	1	80	50	313	15	25	5	20	7,85
91323801	SPB380-1	380	387	1	85	55	338	18	25	5	20	8,50
91324001	SPB400-1	400	407	1	85	55	358	18	25	5	20	10,5
91324501	SPB450-1	450	457	1	90	60	408	18	25	5	20	12,8
91325001	SPB500-1	500	507	1	100	60	458	18	25	5	25	14,1
91325601	SPB560-1	560	567	1	100	60	518	18	25	5	25	17
91326001	SPB600-1	600	607	1	100	60	558	18	25	5	25	17,75
91326301	SPB630-1	630	637	1	100	60	588	18	25	5	25	19,85

MATERIAL CAST-IRON

CAD drawings available on our site
www.chiaravalli.com

Quantity, availability and prices
 on B2B Chiaravalli



SOLID HUB

SPB/2 TYPE

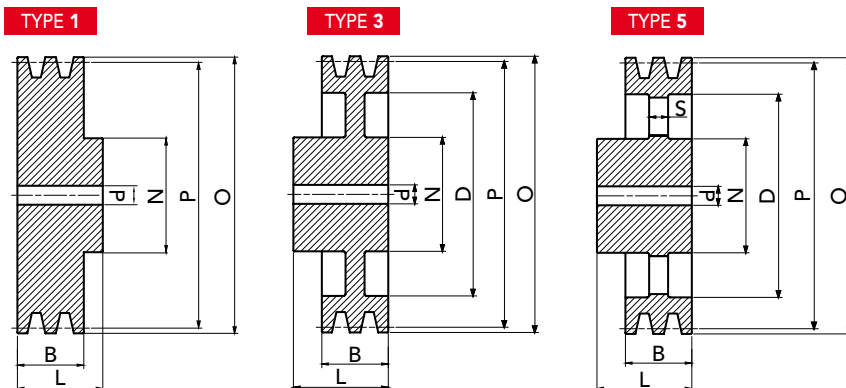

V-PULLEYS PILOT BORE

PRODUCT CODE	PRODUCT MODEL	P	O	GROOVES	N	L	D	S	B	TYPE	d (H9)	WEIGHT (Kg)
91320702	SPB70-2	70	77	2	45	55	-	-	44	1	10	1,03
91320802	SPB80-2	80	87	2	50	55	-	-	44	1	10	1,37
91320902	SPB90-2	90	97	2	50	55	-	-	44	1	10	1,73
91321002	SPB100-2	100	107	2	55	55	-	-	44	1	15	2,17
91321122	SPB112-2	112	119	2	60	55	-	-	44	1	15	2,77
91321202	SPB120-2	120	127	2	60	55	-	-	44	1	15	3,16
91321252	SPB125-2	125	132	2	60	55	-	-	44	1	15	3,47
91321302	SPB130-2	130	137	2	60	55	-	-	44	1	15	3,75
91321402	SPB140-2	140	147	2	65	55	-	-	44	1	20	4,36
91321502	SPB150-2	150	157	2	65	55	-	-	44	1	20	4,99
91321602	SPB160-2	160	167	2	70	55	118	12	44	3	20	4,19
91321702	SPB170-2	170	177	2	70	55	128	12	44	3	20	4,48
91321802	SPB180-2	180	187	2	70	55	138	12	44	3	20	4,82
91322002	SPB200-2	200	207	2	70	55	158	12	44	3	20	5,66
91322122	SPB212-2	212	219	2	77	55	170	14	44	3	20	6,58
91322252	SPB225-2	225	232	2	77	55	184	14	44	3	20	7,07
91322502	SPB250-2	250	257	2	77	55	208	14	44	3	20	8,30
91322802	SPB280-2	280	287	2	80	55	238	14	44	3	20	10,5
91323002	SPB300-2	300	307	2	80	55	258	15	44	5	20	8,20
91323152	SPB315-2	315	322	2	88	60	273	15	44	5	20	9,36
91323402	SPB340-2	340	347	2	88	60	298	15	44	5	20	10,00
91323552	SPB355-2	355	362	2	88	60	313	15	44	5	20	10,72
91323802	SPB380-2	380	387	2	88	60	338	15	44	5	20	12,50
91324002	SPB400-2	400	407	2	88	60	358	18	44	5	20	13,40
91324502	SPB450-2	450	457	2	90	60	408	18	44	5	20	14,20
91325002	SPB500-2	500	507	2	100	65	458	20	44	5	25	18,84
91325602	SPB560-2	560	567	2	100	65	518	20	44	5	25	22
91326302	SPB630-2	630	637	2	100	65	588	20	44	5	25	25,20

MATERIAL **CAST-IRON**

CAD drawings available on our site
www.chiaravalli.com

Quantity, availability and prices
 on B2B Chiaravalli



SOLID HUB

SPB/3 TYPE

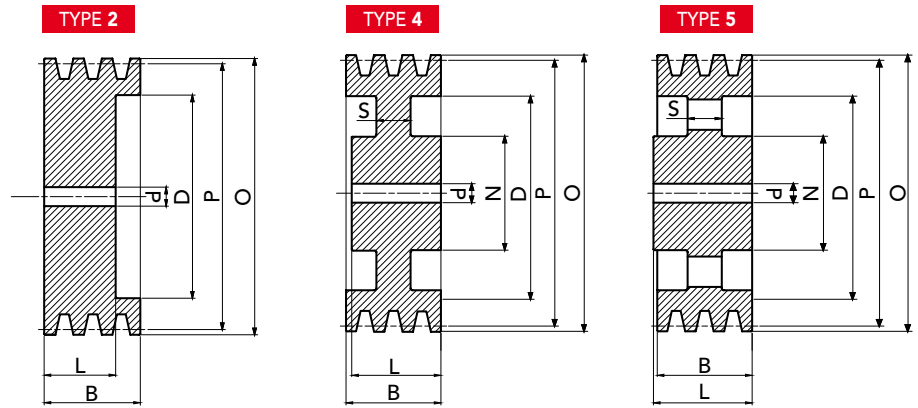

PRODUCT CODE	PRODUCT MODEL	P	O	GROOVES	N	L	D	S	B	TYPE	d (H9)	WEIGHT (Kg)
91320603	SPB60-3	60	67	3	-	-	-	-	63	7	15	0,94
91320703	SPB70-3	70	77	3	-	-	-	-	63	7	15	1,21
91320803	SPB80-3	80	87	3	-	-	-	-	63	7	15	1,67
91320903	SPB90-3	90	97	3	-	-	-	-	63	7	15	2,15
91321003	SPB100-3	100	107	3	-	-	-	-	63	7	15	2,78
91321123	SPB112-3	112	119	3	-	-	-	-	63	7	15	3,58
91321203	SPB120-3	120	127	3	-	-	-	-	63	7	15	4,22
91321253	SPB125-3	125	132	3	-	60	83	-	63	2	15	4,47
91321303	SPB130-3	130	137	3	-	60	86	-	63	2	15	4,86
91321403	SPB140-3	140	147	3	-	60	98	-	63	2	20	5,69
91321503	SPB150-3	150	157	3	-	60	108	-	63	2	20	6,60
91321603	SPB160-3	160	167	3	-	60	118	-	63	2	20	7,50
91321703	SPB170-3	170	177	3	70	60	128	30	63	4	20	6,67
91321803	SPB180-3	180	187	3	80	60	138	18	63	4	20	6,88
91322003	SPB200-3	200	207	3	80	60	158	18	63	4	20	7,88
91322123	SPB212-3	212	219	3	80	60	170	18	63	4	20	8,63
91322253	SPB225-3	225	232	3	80	60	184	18	63	4	20	9,31
91322503	SPB250-3	250	257	3	80	60	208	18	63	4	20	10,92
91322803	SPB280-3	280	287	3	90	60	238	18	63	4	20	12,95
91323003	SPB300-3	300	307	3	90	60	258	18	63	6	20	11,21
91323153	SPB315-3	315	322	3	90	60	273	18	63	6	20	11,78
91323403	SPB340-3	340	347	3	92	60	298	18	63	6	25	14,00
91323553	SPB355-3	355	362	3	92	60	313	18	63	6	25	14,12
91323803	SPB380-3	380	387	3	96	65	338	22	63	6	25	17,00
91324003	SPB400-3	400	407	3	96	65	358	22	63	5	25	18,13
91324253	SPB425-3	425	432	3	96	65	383	22	63	5	20	22,3
91324503	SPB450-3	450	457	3	96	65	408	22	63	5	25	23,5
91325003	SPB500-3	500	507	3	104	75	458	24	63	5	25	25,3
91325603	SPB560-3	560	567	3	104	75	518	24	63	5	25	28,6
91326003	SPB600-3	600	607	3	104	75	558	24	63	5	25	32
91326303	SPB630-3	637	637	3	105	75	588	26	63	5	25	34,8

MATERIAL CAST-IRON

CAD drawings available on our site
www.chiaravalli.com

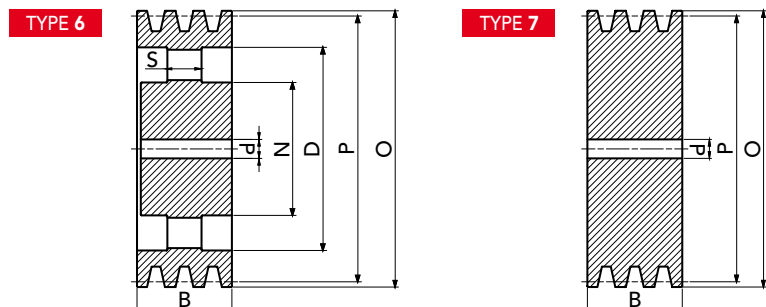

Quantity, availability and prices
 on B2B Chiaravalli



SOLID HUB

SPB/4 TYPE

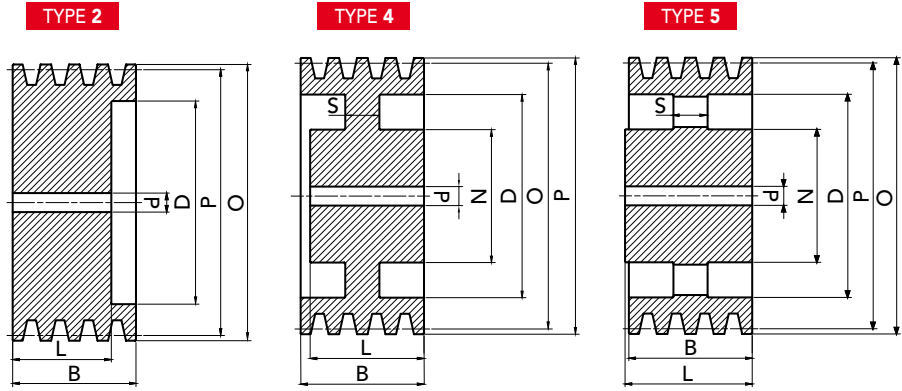

V-PULLEYS PILOT BORE

PRODUCT CODE	PRODUCT MODEL	P	O	GROOVES	N	L	D	S	B	TYPE	d (H9)	WEIGHT (Kg)
91320704	SPB70-4	70	77	4	-	-	-	-	82	7	15	1,60
91320804	SPB80-4	80	87	4	-	-	-	-	82	7	15	2,10
91320904	SPB90-4	90	97	4	-	-	-	-	82	7	15	2,80
91321004	SPB100-4	100	107	4	-	-	-	-	82	7	15	3,60
91321124	SPB112-4	112	119	4	-	-	-	-	82	7	20	4,57
91321204	SPB120-4	120	127	4	-	-	-	-	82	7	20	5,30
91321254	SPB125-4	125	132	4	-	60	83	-	82	2	20	5,00
91321304	SPB130-4	130	137	4	-	60	88	-	82	2	20	5,66
91321404	SPB140-4	140	147	4	-	60	98	-	82	2	20	6,38
91321504	SPB150-4	150	157	4	-	60	108	-	82	2	20	7,31
91321604	SPB160-4	160	167	4	-	60	118	-	82	2	20	8,39
91321704	SPB170-4	170	177	4	70	60	128	30	82	4	20	7,51
91321804	SPB180-4	180	187	4	80	60	138	30	82	4	20	8,57
91322004	SPB200-4	200	207	4	88	60	158	25	82	4	20	10,06
91322124	SPB212-4	212	219	4	88	60	170	25	82	4	20	10,92
91322244	SPB224-4	224	231	4	88	60	183	25	82	4	20	11,77
91322254	SPB225-4	225	232	4	88	60	184	25	82	4	20	11,88
91322364	SPB236-4	236	243	4	88	60	194	25	82	4	20	12,5
91322504	SPB250-4	250	257	4	96	65	208	25	82	4	25	14,46
91322804	SPB280-4	280	287	4	96	65	238	25	82	4	25	16,6
91323004	SPB300-4	300	307	4	96	65	258	20	82	6	25	13,67
91323154	SPB315-4	315	322	4	96	65	273	20	82	6	25	14,36
91323404	SPB340-4	340	347	4	96	65	298	20	82	6	25	19,89
91323554	SPB355-4	355	362	4	96	65	313	20	82	6	25	20
91323804	SPB380-4	380	387	4	104	75	338	24	82	6	25	21
91324004	SPB400-4	400	407	4	104	75	358	24	82	6	25	22
91324254	SPB425-4	425	432	4	104	75	383	24	82	6	25	26
91324504	SPB450-4	450	457	4	104	75	408	24	82	6	25	29
91325004	SPB500-4	500	507	4	112	85	458	28	82	5	25	31
91325604	SPB560-4	560	567	4	112	85	518	28	82	5	25	36
91326004	SPB600-4	600	607	4	115	85	558	28	82	5	25	39
91326304	SPB630-4	630	637	4	120	85	588	28	82	5	25	41

TYPE 6

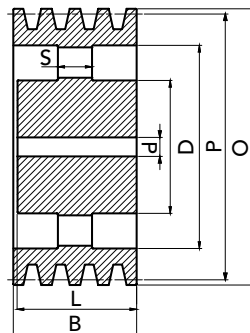

TYPE 7

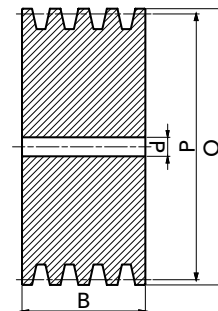

MATERIAL CAST-IRON

CAD drawings available on our site www.chiaravalli.com

Quantity, availability and prices on B2B Chiaravalli



SOLID HUB

SPB/5 TYPE

TYPE 2

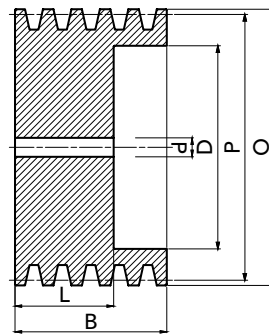

TYPE 4

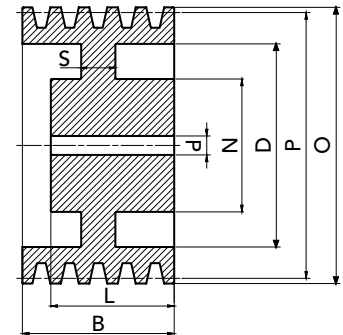

PRODUCT CODE	PRODUCT MODEL	P	O	GROOVES	N	L	D	S	B	TYPE	d (H9)	WEIGHT (Kg)
91320705	SPB70-5	70	77	5	-	-	-	-	101	7	15	1,70
91320805	SPB80-5	80	87	5	-	-	-	-	101	7	15	2,62
91320905	SPB90-5	90	97	5	-	-	-	-	101	7	15	3,50
91321005	SPB100-5	100	107	5	-	-	-	-	101	7	15	4,36
91321125	SPB112-5	112	119	5	-	-	-	-	101	7	20	5,62
91321205	SPB120-5	120	127	5	-	-	-	-	101	7	20	7,50
91321255	SPB125-5	125	132	5	-	60	83	-	101	2	20	5,70
91321305	SPB130-5	130	137	5	-	60	88	-	101	2	20	6,34
91321405	SPB140-5	140	147	5	-	60	98	-	101	2	20	7,02
91321505	SPB150-5	150	157	5	-	60	108	-	101	2	20	8,12
91321605	SPB160-5	160	167	5	-	60	118	-	101	2	20	9,25
91321705	SPB170-5	170	177	5	70	60	128	30	101	4	20	8,35
91321805	SPB180-5	180	187	5	80	70	138	30	101	4	20	10,56
91322005	SPB200-5	200	207	5	96	70	158	30	101	4	25	12,76
91322125	SPB212-5	212	219	5	96	70	170	30	101	4	25	13,42
91322255	SPB225-5	225	232	5	96	70	183	25	101	4	25	13,75
91322505	SPB250-5	250	257	5	104	75	208	25	101	4	25	16,85
91322805	SPB280-5	280	287	5	104	75	238	25	101	4	25	19,74
91323005	SPB300-5	300	307	5	104	75	258	22	101	6	25	16,93
91323155	SPB315-5	315	322	5	104	75	273	22	101	6	25	17,66
91323405	SPB340-5	340	347	5	104	75	298	22	101	6	25	22,48
91323555	SPB355-5	355	362	5	104	75	313	22	101	6	25	21,40
91323805	SPB380-5	380	387	5	112	85	338	24	101	6	25	23,00
91324005	SPB400-5	400	407	5	112	85	358	26	101	6	25	26,30
91324255	SPB425-5	425	432	5	112	85	383	26	101	6	25	28,00
91324505	SPB450-5	450	457	5	112	85	408	26	101	6	25	30
91325005	SPB500-5	500	507	5	120	90	458	30	101	6	25	35
91325605	SPB560-5	560	567	5	120	90	518	30	101	6	25	37
91326005	SPB600-5	600	607	5	120	90	558	30	101	6	25	42
91326305	SPB630-5	630	637	5	128	90	588	30	101	6	25	45

MATERIAL CAST-IRON

TYPE 6

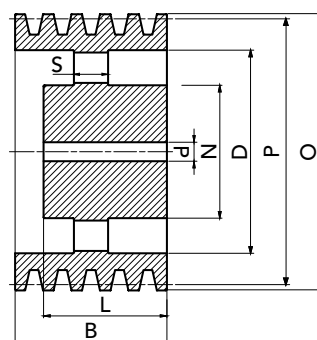

TYPE 7

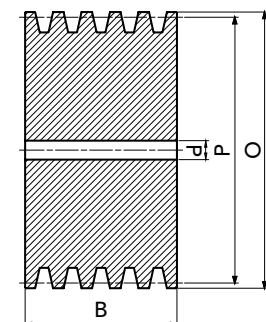

CAD drawings available on our site
www.chiaravalli.com

Quantity, availability and prices
 on B2B Chiaravalli



SOLID HUB

SPB/6 TYPE

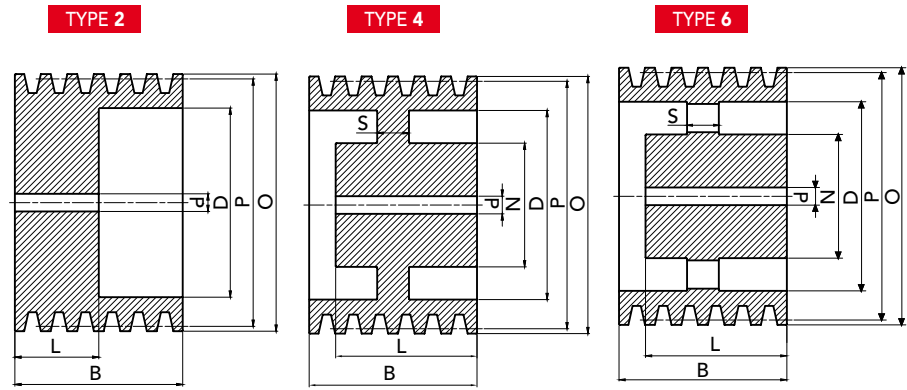

V-PULLEYS PILOT BORE

PRODUCT CODE	PRODUCT MODEL	P	O	GROOVES	N	L	D	S	B	TYPE	d (H9)	WEIGHT (Kg)
91321406	SPB140-6	140	147	6	-	60	98	-	120	2	20	8,00
91321506	SPB150-6	150	157	6	-	60	108	-	120	2	20	8,90
91321606	SPB160-6	160	167	6	-	65	118	-	120	2	20	10,38
91321706	SPB170-6	170	177	6	70	65	128	40	120	4	20	12,70
91321806	SPB180-6	180	187	6	80	70	138	40	120	4	20	12,99
91322006	SPB200-6	200	207	6	96	70	158	40	120	4	25	14,29
91322126	SPB212-6	212	219	6	104	80	170	35	120	4	25	14,91
91322256	SPB225-6	225	232	6	104	80	183	30	120	4	25	16,65
91322506	SPB250-6	250	257	6	104	80	208	25	120	4	25	18,82
91322806	SPB280-6	280	287	6	104	80	238	25	120	4	25	22
91323006	SPB300-6	300	307	6	104	80	258	24	120	6	25	21
91323156	SPB315-6	315	322	6	120	90	273	24	120	6	25	22,3
91323406	SPB340-6	340	347	6	120	90	298	24	120	6	25	23
91323556	SPB355-6	355	362	6	120	90	313	24	120	6	25	24,95
91323806	SPB380-6	380	387	6	120	100	338	28	120	6	25	29
91324006	SPB400-6	400	407	6	120	100	358	28	120	6	25	31
91324256	SPB425-6	425	432	6	120	100	383	28	120	6	25	33,50
91324506	SPB450-6	450	457	6	120	100	408	28	120	6	25	36
91325006	SPB500-6	500	507	6	128	105	458	33	120	6	25	45
91325606	SPB560-6	560	567	6	128	105	518	33	120	6	25	47
91326006	SPB600-6	600	607	6	129	105	558	33	120	6	25	49,05

MATERIAL CAST-IRON

CAD drawings available on our site
www.chiaravalli.com

Quantity, availability and prices
on B2B Chiaravalli



SOLID HUB

SPC/1 TYPE

TYPE 1

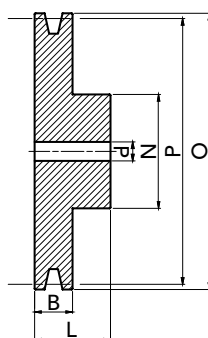

TYPE 3

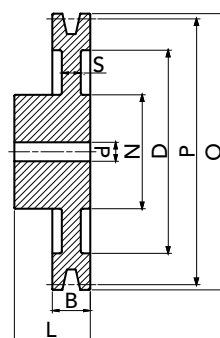

PRODUCT CODE	PRODUCT MODEL	P	O	GROOVES	N	L	D	S	B	TYPE	d (H9)	WEIGHT (Kg)
91421201	SPC120-1	120	129,6	1	65	50	-	-	34	1	15	2,66
91421401	SPC140-1	140	149,6	1	70	50	-	-	34	1	20	3,55
91421501	SPC150-1	150	159,6	1	70	50	-	-	34	1	20	4,09
91421601	SPC160-1	160	169,6	1	72	50	-	-	34	1	20	4,68
91421801	SPC180-1	180	189,6	1	76	50	123	16	34	3	20	5,05
91422001	SPC200-1	200	209,6	1	76	50	143	16	34	3	20	5,85
91422251	SPC225-1	225	234,6	1	86	50	168	16	34	3	20	7,20
91422501	SPC250-1	250	259,6	1	86	50	193	16	34	3	20	8,51
91422801	SPC280-1	280	289,6	1	86	50	223	16	34	3	20	10,18
91423001	SPC300-1	300	309,6	1	86	50	243	16	34	3	20	11,76

MATERIAL **CAST-IRON**CAD drawings available on our site
www.chiaravalli.comQuantity, availability and prices
on B2B Chiaravalli



SOLID HUB

SPC/2 TYPE

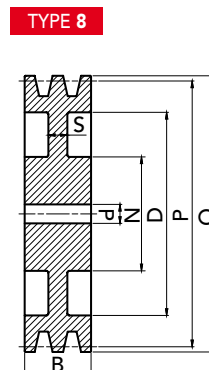
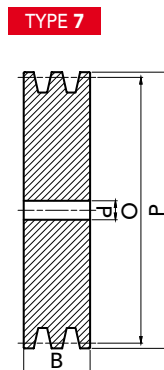
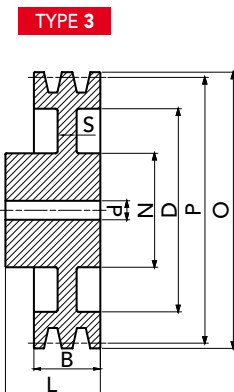

V-PULLEYS PILOT BORE

PRODUCT CODE	PRODUCT MODEL	P	O	GROOVES	N	L	D	S	B	TYPE	d (H9)	WEIGHT (Kg)
91421202	SPC120-2	120	129,6	2	-	-	-	-	59,5	7	15	3,9
91421402	SPC140-2	140	149,6	2	-	-	-	-	59,5	7	20	5,3
91421502	SPC150-2	150	159,6	2	-	-	-	-	59,5	7	20	6,16
91421602	SPC160-2	160	169,6	2	-	-	-	-	59,5	7	20	7,13
91421802	SPC180-2	180	189,6	2	80	-	123	30	59,5	8	20	7,82
91422002	SPC200-2	200	209,6	2	80	60	143	20	59,5	3	20	9,71
91422252	SPC225-2	225	234,6	2	88	60	169	18	59,5	3	20	10,13
91422502	SPC250-2	250	259,6	2	92	60	193	18	59,5	3	20	11,93
91422802	SPC280-2	280	289,6	2	92	60	223	18	59,5	3	20	14,18
91423002	SPC300-2	300	309,6	2	92	60	243	18	59,5	3	20	15,8

MATERIAL CAST-IRON

CAD drawings available on our site
www.chiaravalli.com

Quantity, availability and prices
on B2B Chiaravalli



V-PULLEYS PILOT BORE

SOLID HUB

SPC/3 TYPE

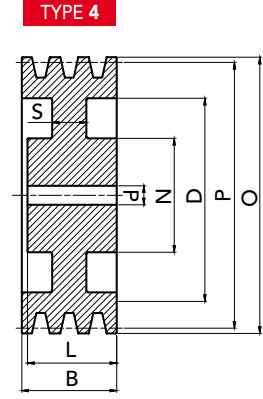
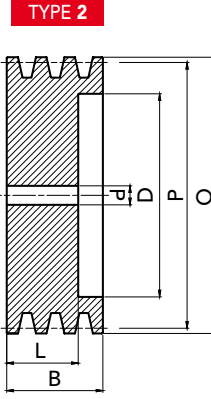

PRODUCT CODE	PRODUCT MODEL	P	O	GROOVES	N	L	D	S	B	TYPE	d (H9)	WEIGHT (Kg)
91421403	SPC140-3	140	149,6	3	-	65	83	-	85	2	20	6,7
91421503	SPC150-3	150	159,6	3	-	65	93	-	85	2	20	7,65
91421603	SPC160-3	160	169,6	3	-	65	103	-	85	2	20	8,92
91421803	SPC180-3	180	189,6	3	82	65	123	35	85	4	20	9,83
91422003	SPC200-3	200	209,6	3	86	65	143	25	85	4	20	11,13
91422253	SPC225-3	225	234,6	3	90	70	169	21	85	4	20	13,11
91422503	SPC250-3	250	259,6	3	92	70	193	21	85	4	20	15,31
91422803	SPC280-3	280	289,6	3	92	70	223	21	85	4	20	18,11
91423003	SPC300-3	300	309,6	3	92	70	243	21	85	4	20	20

MATERIAL **CAST-IRON**

CAD drawings available on our site www.chiaravalli.com

Quantity, availability and prices on B2B Chiaravalli



SOLID HUB

SPC/4 TYPE

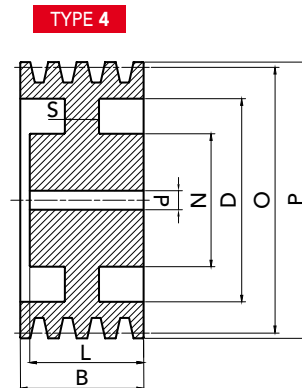
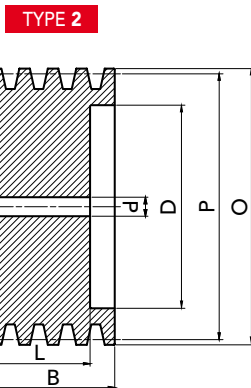

V-PULLEYS PILOT BORE

PRODUCT CODE	PRODUCT MODEL	P	O	GROOVES	N	L	D	S	B	TYPE	d (H9)	WEIGHT (Kg)
91421404	SPC140-4	140	149,6	4	-	80	83	-	110,5	2	20	8,5
91421504	SPC150-4	150	159,6	4	-	80	93	-	110,5	2	20	9,76
91421604	SPC160-4	160	169,6	4	-	80	103	-	110,5	2	20	11,16
91421804	SPC180-4	180	189,6	4	82	80	123	60	110,5	4	20	13,28
91422004	SPC200-4	200	209,6	4	90	90	143	60	110,5	4	20	17,41
91422254	SPC225-4	225	234,6	4	90	90	169	50	110,5	4	25	19,16
91422504	SPC250-4	250	259,6	4	100	90	193	30	110,5	4	25	20,48
91422804	SPC280-4	280	289,6	4	100	90	223	25	110,5	4	25	23,14
91423004	SPC300-4	300	309,6	4	100	90	243	25	110,5	4	25	25,5

MATERIAL CAST-IRON

CAD drawings available on our site
www.chiaravalli.com

Quantity, availability and prices
 on B2B Chiaravalli

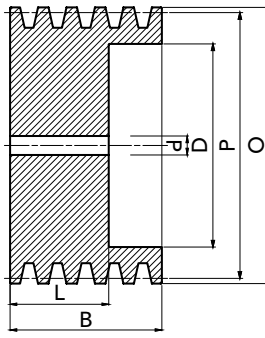
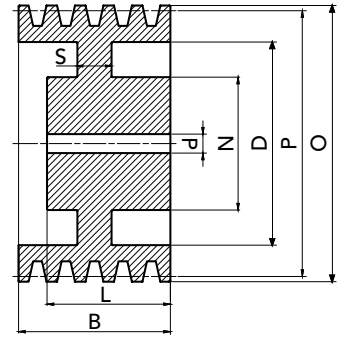
SOLID HUB
SPC/5 TYPE
TYPE 2

TYPE 4

PRODUCT CODE	PRODUCT MODEL	P	O	GROOVES	N	L	D	S	B	TYPE	d (H9)	WEIGHT (Kg)
91421505	SPC150-5	150	159,6	5	-	96	93	-	136	2	20	12,5
91421605	SPC160-5	160	169,6	5	-	96	103	-	136	2	20	14,5
91421805	SPC180-5	180	189,6	5	82	96	123	75	136	4	20	16,2
91422005	SPC200-5	200	209,6	5	90	100	143	80	136	4	25	20,23
91422255	SPC225-5	225	234,6	5	90	100	169	60	136	4	25	22,86
91422505	SPC250-5	250	259,6	5	102	100	193	50	136	4	25	26,7
91422805	SPC280-5	280	289,6	5	102	100	223	40	136	4	25	29,93
91423005	SPC300-5	300	309,6	5	104	100	243	25	136	4	25	28,4

 MATERIAL **CAST-IRON**

 CAD drawings available on our site
www.chiaravalli.com

 Quantity, availability and prices
 on B2B Chiaravalli



PULEGGE A GOLA TRAPEZOIDALI IN GHISA

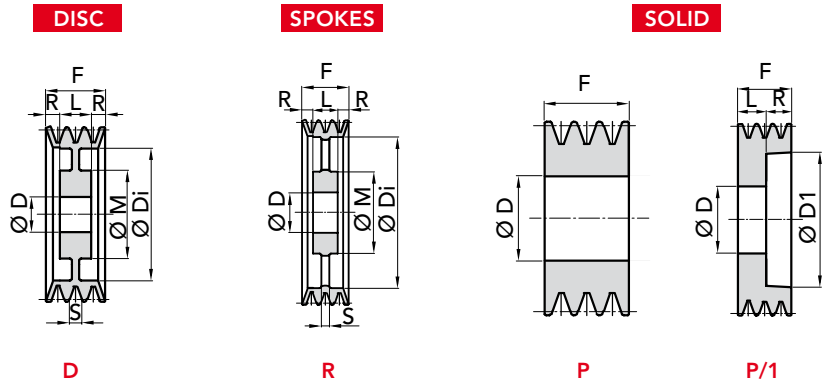

for LOCKING DEVICES
SPA TYPE

Dp	P. NUMBER Ø 55 H8	P. NUMBER Ø 65 H8	P. NUMBER Ø 80 H8	N° GROOVES	EXEC.	F	L	Ø M	R	Ø Di	S	WEIGHT Kg.
90	91250902			2	P	35						0,20
	91250903			3	P	50						1,10
	91250905			5	P	80						2,00
95	91250952			2	P	35						0,85
100	91251001			1	P	20						0,50
	91251002	91261002		2	P	35						0,90
	91251003			3	P	50						1,30
105	91251052			2	P	35						0,95
120	91251202			2	P/1	35	27		8	88		1,00
125		91261252		2	P/1	35	27		8	92		1,00
		91261253		3	P/1	50	27		23	92		1,80
		91261254		4	P/1	65	27		38	92		2,40
130		91261303		3	P/1	50	27		23	97		1,75
140		91261403		4	P/1	65	27		38	107		1,50
150	91251502			2	P/1	35	27		8	117		1,35
		91261504		4	P/1	65	27		38	117		2,15
160	91251602	91261602		2	P/1	35	27		8	127		1,50
		91261603		3	P/1	50	27		23	127		1,90
170	91251702			2	D	35	27		4	137	27	1,60
180	91251802	91261802		2	D	35	27		4	147	27	1,70
	91251803	91271803		3	D	50	27		11,5	147	27	2,40
190		91261902		2	D	35	27	120	4	157	12	1,80
		91261903		3	D	50	27	120	11,5	157	12	2,50
200	91252002	91262002		2	D	35	27	120	4	167	12	1,90
		91262003		3	D	50	27	120	11,5	167	14	2,60
		91262004		4	D	65	27	120	19	167	14	3,30
225	91252252	91262252		2	D	35	27	120	4	192	12	2,20
		91262253		3	D	50	27	120	11,5	192	14	2,80
250	91252502			2	R	35	27	130	4	217	14	2,80
			91282503	3	R	50	27	130	11,5	217	14	3,50
		91262504		4	R	65	27	130	19	217	14	4,20
300			91283004	4	R	65	27	130	19	267	14	3,40

MATERIAL CAST-IRON

 CAD drawings available on our site
www.chiaravalli.com

 Quantity, availability and prices
 on B2B Chiaravalli



for LOCKING DEVICES

SPB TYPE

DISC

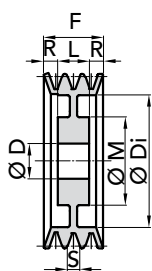

D

SPOKES

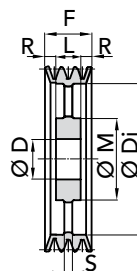

R

SOLID

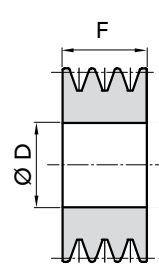

P

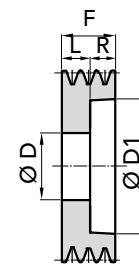

P/1

Dp	P. NUMBER Ø 55 H8	P. NUMBER Ø 65 H8	P. NUMBER Ø 80 H8	N° GROOVES	EXEC.	F	L	Ø M	R	Ø Di	S	WEIGHT Kg.
112	91351121			1	P	25						1,50
	91351122			2	P/1	44	27		17	70		1,90
120		91361202		2	P/1	44	27		17	78		2,10
		91361203		3	P/1	63	27		36	78		3,80
		91361204		4	P/1	82	27		55	78		4,20
125	91351251			1	P	25						1,90
		91371252		2	P/1	44	27		17	83		2,40
		91361253		3	P/1	63	27		36	83		4,00
130		91361302	91381302	2	P/1	44	27		17	90		2,60
		91361303	91381303	3	P/1	63	27		36	90		4,20
		91361304	91381304	4	P/1	82	27		55	90		5,00
			91381305	5	P/1	101	27		74	90		5,50
			91381306	6	P/1	120	27		93	90		6,00
140	91351402	91361402	91381402	2	P/1	44	27		17	98		2,90
		91361403	91381403	3	P/1	63	27		36	98		4,40
		91361404	91381404	4	P/1	82	27		55	98		5,30
			91381405	5	P/1	101	27		74	98		5,80
150	91351501 91351502	91361501		1	P	25						2,40
		91361502	91381502	2	P/1	44	27		17	108		3,20
		91361503	91381503	3	P/1	63	27		36	108		4,60
		91361504	91381504	4	P/1	82	27		55	108		5,50
			91381505	5	P/1	101	27		74	108		6,00
160	91351601	91361601		1	P	25						2,50
		91361602	91381602	2	P/1	44	27		17	118		3,30
		91361603	91381603	3	P/1	63	27		36	118		4,80
			91381604	4	P/1	82	27		55	118		5,70
			91381605	5	P/1	101	27		74	118		7,00
			91381606	6	P/1	120	27		93	118		8,30
170			91381702	2	D	44	27		8,5	128	27	3,40
		91361703	91381703	3	D	63	27		18	128	27	5,10
			91381704	4	D	82	27		27,5	128	27	5,90
			91381705	5	D	101	27		37	128	27	7,40
180				1	P	25						3,10
		91361802	91381802	2	D	44	27		8,5	138	27	3,90
		91361803	91381803	3	D	63	27		18	138	27	5,20
		91361804	91381804	4	D	82	27		27,5	138	27	6,20
			91381805	5	D	101	27		37	138	27	7,50
			91381806	6	D	120	27		46,5	138	27	8,90

MATERIAL **CAST-IRON**

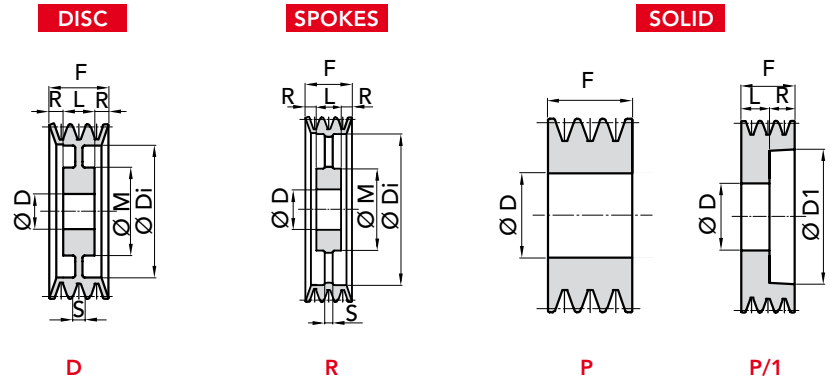

for LOCKING DEVICES

SPB TYPE

Dp	P. NUMBER Ø 55 H8	P. NUMBER Ø 65 H8	P. NUMBER Ø 80 H8	N° GROOVES	EXEC.	F	L	Ø M	R	Ø Di	S	WEIGHT Kg.
190		91361901	91381902	1	P	25						3,50
			91381903	2	D	44	27		8,5	148	27	6,50
			91381904	3	D	63	27		18	148	27	7,00
			91381905	4	D	82	27		27,5	148	27	8,00
				5	D	101	27		37	148	27	9,00
200		91362001 91372002 91362003 91362004	91382001	1	P	25						4,00
			91382002	2	D	44	27	120	8,5	158	15	7,00
			91382003	3	D	63	27	120	18	158	15	8,00
			91382004	4	D	82	27	120	27,5	158	15	9,00
			91382005	5	D	101	27	120	37	158	15	10,0
			91382006	6	D	120	27	120	46,5	158	18	11,0
212		91362122 91362123 91362124	91382122	2	D	44	27	120	8,5	170	15	7,00
			91382123	3	D	63	27	120	18	170	15	8,50
			91382124	4	D	82	27	120	27,5	170	15	10,0
			91382125	5	D	101	27	120	37	170	15	11,0
225	91352253	91372252 91362253 91362254	91382252	2	D	44	27	120	8,5	183	15	7,70
			91382253	3	D	63	27	120	18	183	15	9,00
			91382254	4	D	82	27	120	27,5	183	15	10,5
			91382255	5	D	101	27	120	37	183	15	11,5
			91382256	6	D	120	27	120	46,5	183	18	13,0
240			91382403	3	D	63	27	120	18	198	16	11,0
250	91352501 91352502	91372502 91372503 91362504	91382502	1	D	25	25	130		208	16	6,20
			91382503	2	D	44	27	130	8,5	208	16	8,50
			91382504	3	D	63	27	130	18	208	16	11,0
			91382505	4	D	82	27	130	27,5	208	16	12,0
			91382506	5	D	101	27	130	37	208	16	18,0
				6	D	120	27	130	46,5	208	18	22,0
280			91382802	1	D	25	25	120		238	16	6,50
			91382803	2	D	44	27	120	8,5	238	16	10,0
			91382804	3	D	63	27	120	18	238	16	12,5
			91382805	4	D	82	27	120	27,5	238	16	14,0
				5	D	101	27	130	37	238	16	21,0
300	91353001		91383004	1	R	25	25	130		258	15	7,00
			91383005	4	R	82	27	130	27,5	258	20	16,0
				5	R	101	27	130	37	258	22	19,0
315		91363153	91383154	3	R	63	27	130	18	273	18	14,0
			91383155	4	R	82	27	130	27,5	273	20	20,0
				5	R	101	27	130	37	273	22	22,0
355	91353551			1	R	25	25	130		308	16	16,0

 MATERIAL **CAST-IRON**

 CAD drawings available on our site
www.chiaravalli.com

 Quantity, availability and prices
 on B2B Chiaravalli



for LOCKING DEVICES

SPC TYPE

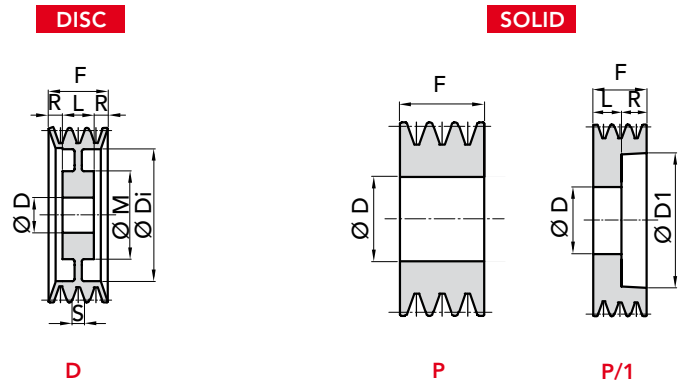

Dp	P. NUMBER Ø 55 H8	P. NUMBER Ø 65 H8	P. NUMBER Ø 80 H8	N° GROOVES	EXEC.	F	L	Ø M	R	Ø Di	S	WEIGHT Kg.
160			91481603	3	P/1	85	27		58	103		2,60
190			91481903	3	P/1	85	27		58	133		2,90
225			91482253	3	D	85	27	120	29	168	25	3,40

V-BELT PULLEYS for LOCKING DEVICES SPC

MATERIAL **CAST-IRON**

CAD drawings available on our site
www.chiaravalli.com

Quantity, availability and prices
 on B2B Chiaravalli

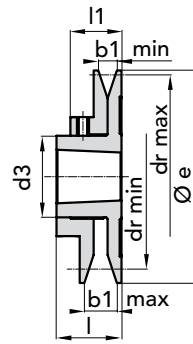

EXECUTION 1

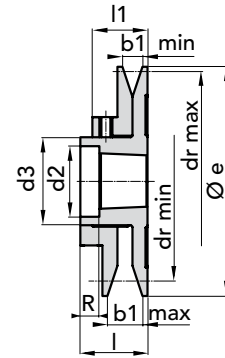

EXECUTION 2

PULLEY TYPE	P. NUMBER	EXEC.	N° GROOVES	BUSHE	Ø e	l	l1	b1		dr		d2	d3	R	GRUB DIN 916 UNI 5929	SECTION BELT	WEIGHT Kg.
								min	max	min	max						
PRB - 93	90000931	2	1	1108	93	36,5	29	10	17,5	57	78	46	M60x2	13,5	No.4 M6x6	Z 10x6 A 13x8	0,86
PRB - 108	90001081	1	1	1215	108	38	30,5	10	17,5	68	92	-	M72x2	-	No.4 M6x6	Z 10x6 A 13x8 SPZ SPA	1,18
PRB - 120	90001201	1	1	1215	120	38	30,5	10	17,5	80	104	-	M72x2	-	No.4 M6x6	Z 10x6 A 13x8 SPZ SPA	1,46
PRB - 138	90001381	1	1	1615	138	38	30,5	10	17,5	98	122	-	M85x2	-	No.4 M6x6	Z 10x6 A 13x8 SPZ SPA	2,00
PRB - 160	90001601	2	1	1615	160	45	35,5	13	22,5	108	138	69	M85x2	6,5	No.4 M8x8	A 13x8 B 17x11 SPA SPB	3,04
PRB - 180	90001801	2	1	2012	180	45	35,5	13	22,5	128	158	87	M110x2	12,5	No.4 M8x8	A 13x8 B 17x11 SPA SPB	3,80
PRB - 200	90002001	2	1	2012	200	45	35,5	13	22,5	149	177	87	M110x2	12,5	No.4 M8x8	A 13x8 B 17x11 SPA SPB	4,75

MATERIAL **CAST-IRON G20**
UNI 5007

CAD drawings available on our site
www.chiaravalli.com

Quantity, availability and prices
on B2B Chiaravalli



ADJUSTABLE V-BELTS PULLEY PRB TYPE

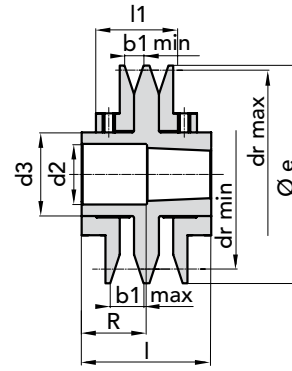

EXECUTION 3

ADJUSTABLE V-BELTS PULLEY PRB TYPE

PULLEY TYPE	P. NUMBER	EXEC. N°	BUSHE GROOVES	Ø e	l	l1	b1		dr		d2	d3	R	GRUB DIN 916 UNI 5929	SECTION BELT	WEIGHT Kg.	
							min	max	min	max							
PRB2 - 108	90001082	3	2	1215	108	73	58	10	17,5	68	92	57	M72x2	34,5	No. 8 M6x6	Z 10x6 A 13x8 SPZ SPA	2,40
										70	100						
										75	93						
										76	102						
PRB2 - 120	90001202	3	2	1215	120	73	58	10	17,5	80	104	57	M72x2	34,5	No. 8 M6x6	Z 10x6 A 13x8 SPZ SPA	2,65
										82	112						
										87	105						
										88	114						
PRB2 - 138	90001382	3	2	1615	138	73	58	10	17,5	98	122	69	M85x2	34,5	No. 8 M6x6	Z 10x6 A 13x8 SPZ SPA	3,60
										100	130						
										105	123						
										106	132						
PRB2 - 160	90001602	3	2	1615	160	87	68	13	22,5	108	138	69	M85x2	48,5	No. 8 M8x8	A 13x8 B 17x11 SPA SPB	5,60
										112	150						
										114	140						
										117	153						
PRB2 - 180	90001802	3	2	2012	180	87	68	13	22,5	128	158	87	M110x2	54	No. 8 M8x8	A 13x8 B 17x11 SPA SPB	7,15
										132	170						
										134	160						
										137	173						
PRB2 - 200	90002002	3	2	2012	200	87	68	13	22,5	149	177	87	M110x2	54	No. 8 M8x8	A 13x8 B 17x11 SPA SPB	8,92
										152	190						
										155	179						
										159	193						

MATERIAL **CAST-IRON G20**
UNI 5007

CAD drawings available on our site
www.chiaravalli.com

Quantity, availability and prices
on B2B Chiaravalli



TYPES

Grooved pulleys designed for industrial transmissions are identified by reference to the dimensions and the groove pitch in the following types: **PPV-J – PPV-L**

PROFILE DIMENSIONS

The transverse profile dimensions of a grooved pulley are shown in the figure and in the table.

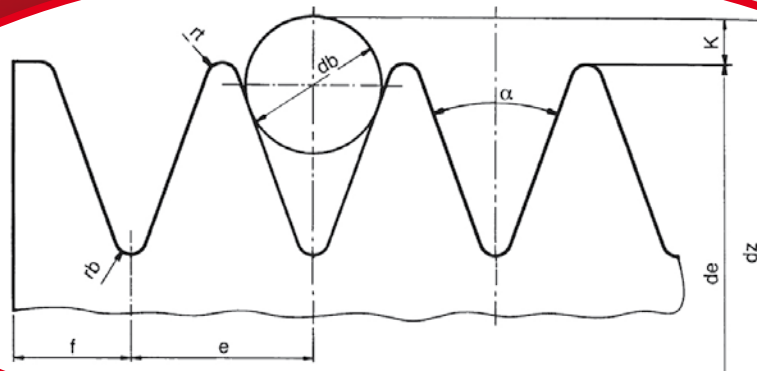

TABLE

TYPE	PPV-J	PPV-L
Grooves pitch e	2.34	4.70
Tolerance for e*	± 0.03	± 0.05
Sum of tolerances e**	± 0.30	± 0.30
Race angle a** ±0,5	40°	40°
rt min.	0.20	0.40
rb max	0.40	0.40
Diameter of the control sphere or roller db ± 0.01	1.50	3.50
2K** nominal	0.23	2.36
f min.	1.8	3.3

* = this tolerance applies to the distance between the axes of two consecutive grooves

** = the sum of all the tolerances "e" for all the races of each pulley must not exceed the value foreseen in the table

* = the axis of each groove must form a $90^\circ \pm 0.5^\circ$ angle with the pulley axis

** = K is not in relation to the pulley's nominal diameter but is measured from the position of the measurement sphere or roller.



PITCH LINE DIAMETER

The position of a grooved belt in contact with the corresponding pulley is shown in cross-section in the figure.

The real pitch line diameter **dp** of a grooved pulley measured along the belt is slightly greater than the actual diameter **de** and the exact value depends on the type of belt used.

For the purposes of illustration, the table shows the value **be** normally adopted to calculate the transmission ratio.

In practice it is sufficient to use the actual diameter **de** to calculate the transmission ratio.

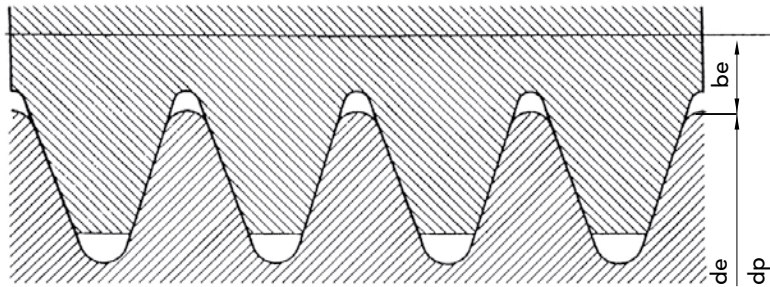

$$dp \approx de + 2be$$

TYPE	PPV-J	PPV-L
2 be	2	5

DESIGNATION

The designation includes the following details, in the order given: the "pulley" domination, the reference of the current standard, the number of grooves, the type and the actual diameter expressed in millimetres.

An example of the designation for a PPV-J type grooved pulley designed for industrial transmissions with 8 grooves and an actual diameter of 200mm

8 PPV-J 200

DEGREE OF FINISH OF THE GROOVES

The surface roughness of the grooves shall be Ra 3.2 in compliance with ISO 254.

MATERIALS

C45 UNI 7845

Pulleys are manufactured in steel.

BALANCING

UNI 4218 – ISO 1940

Pulleys prepared for a tapered bush are statically balanced within grade G.6.3.

It is possible to perform dynamic balancing, on request.

Dynamic balancing is essential for speeds exceeding 30 m/s.



DESIGN POWER CALCULATION

Make a note of the nominal power to be transmitted **P** (kw) (normally the nominal power of the electric motor), select the service factor **Co** based on the table and calculate the design power output **Pc** (kw) as follows: **Pc = Co x P**

Service factor (Co)

MOTOR TYPE

CLASS A

- Synchronous and asynchronous, squirrel cage, normal torque, alternating current motor.
- Shunt winding direct current motor
- Internal combustion engine (steady-state condition ³ 700 r.p.m.)
- Turbines

CLASS B

- Asynchronous, squirrel cage, high torque alternating current motor
- Compound winding direct current motor
- Internal combustion engine (steady-state condition ³ 700 r.p.m.)
- Clutches

TYPE OF MACHINE DRIVEN	Class A Motor			Class B Motor		
	Number of daily operating hours					
	<10	10÷16	>16	<10	<10÷16	>16
• Liquid mixers • Blowers • Extractors • Centrifuge fans • Lightweight conveyors	1	1.1	1.2	1.1	1.2	1.3
• Mixers designed for pasty products • Blenders • Generators • Laundry machines • Machine tools	1.1	1.2	1.3	1.2	1.3	1.4
• Rotary compressors • Rotary pumps • Sieves • Heavyweight conveyors • Spraying systems • Dynamo • Bakery machines • Printing machines • Wood working machines • Axial fans • Brick making machines	1.2	1.3	1.4	1.3	1.4	1.5
• Piston compressors • Piston pumps • Crushers • Bucket elevators • Elevators • Paper making machines • Mills • Hoists	1.4	1.5	1.6	1.5	1.6	1.8
• Grinding machines • Crushing machines • Drainage systems • Calenders and extruders for rubber and plastics	1.6	1.7	1.8	1.7	1.8	2

CROSS-SECTION SELECTION

R.p.m. of smallest pulley The type of cross-section is selected by using the diagram shown below.

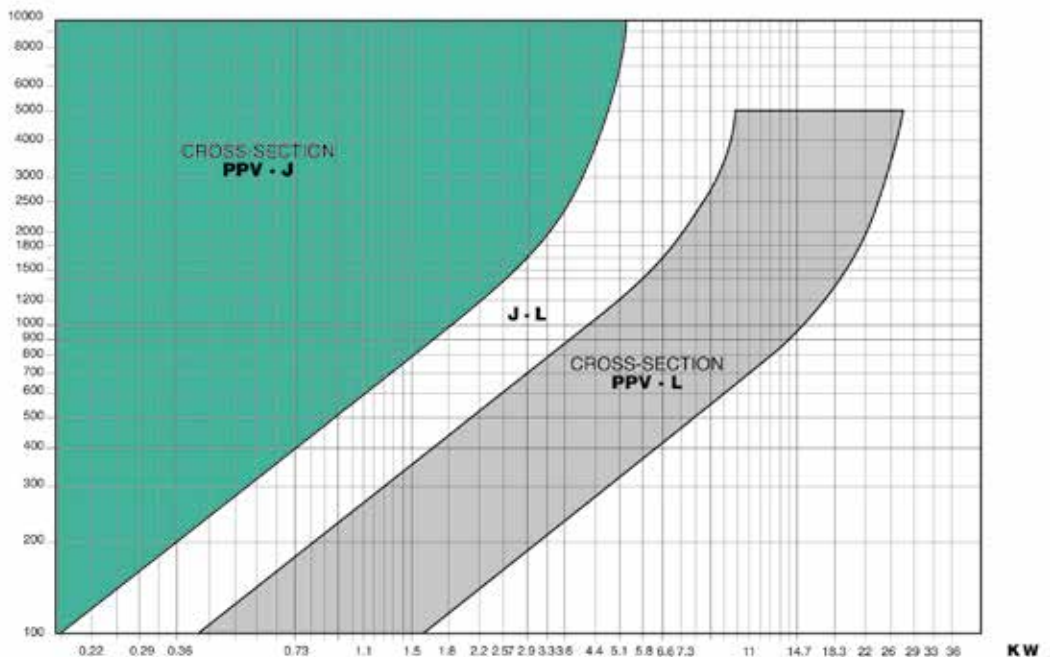



V-BELT PULLEYS PPV-J MICRO V DIMENSIONS

PPV-J TYPE pitch $2,34 \pm 0,025$

N° GROOVES	F±0.1	P
8	23	3.31
12	32.5	3.38
16	42	3.45

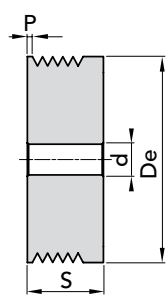

EXEC. 1

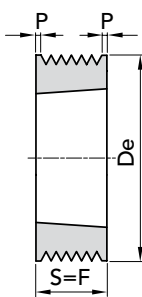

EXEC. 2

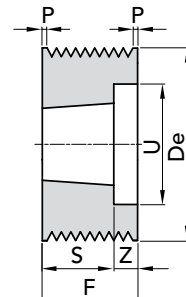

EXEC. 3

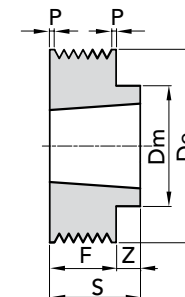

EXEC. 4

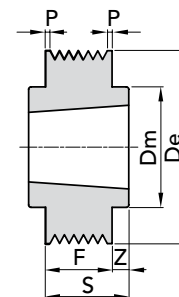

EXEC. 5

De	P. NUMBER	EXEC.	N° GROOVES	BUSHE	S	Z	Dm	U	d	WEIGHT Kg.
40	48108040	1	8	-	32	-	-	-	12	0,24
	48112040	1	12	-	41,5	-	-	-	12	0,31
	48116040	1	16	-	51	-	-	-	12	0,38
45	48108045	1	8	-	32	-	-	-	12	0,32
	48112045	1	12	-	41,5	-	-	-	12	0,41
	48116045	1	16	-	51	-	-	-	12	0,50
50	48108050	1	8	-	32	-	-	-	12	0,40
	48112050	1	12	-	41,5	-	-	-	12	0,52
	48116050	1	16	-	51	-	-	-	12	0,63
56	48108056	2	8	1108	23	-	-	-	-	0,39
	48112056	3	12	1108	23	9,5	-	40	-	0,65
	48116056	1	16	-	51	-	-	-	12	0,81
63	48108063	2	8	1108	23	-	-	-	-	0,50
	48112063	3	12	1108	23	9,5	-	46	-	0,39
	48116063	1	16	-	51	-	-	-	12	1,05
71	48108071	2	8	1108	23	-	-	-	-	0,64
	48112071	3	12	1108	23	9,5	-	46	-	0,57
	48116071	2	16	1215	42	-	-	55	-	0,63
75	48108075	2	8	1108	23	-	-	-	-	0,72
	48112075	3	12	1610	26	6,5	-	60	-	0,38
	48116075	3	16	1610	26	16	-	60	-	0,46
80	48108080	4	8	1610	26	3	70	-	-	0,41
	48112080	3	12	1610	26	6,5	-	60	-	0,52
	48116080	3	16	1610	26	16	-	60	-	0,64
85	48108085	4	8	1610	26	3	70	-	-	0,51
	48112085	3	12	1610	26	6,5	-	60	-	0,66
	48116085	3	16	1610	26	16	-	60	-	0,84
90	48108090	4	8	1610	26	3	70	-	-	0,62
	48112090	3	12	1610	26	6,5	-	74	-	0,76
	48116090	3	16	1610	26	16	-	74	-	0,87
95	48108095	4	8	1610	26	3	82	-	-	0,78
	48112095	3	12	1610	26	6,5	-	74	-	0,93
	48116095	3	16	1610	26	16	-	74	-	1,08
100	48108100	4	8	1610	26	3	82	-	-	0,90
	48112100	3	12	1610	26	6,5	-	74	-	1,10
	48116100	3	16	1610	26	16	-	74	-	1,32

De	P. NUMBER	EXEC.	N° GROOVES	BUSHE	S	Z	Dm	U	d	WEIGHT Kg.
106	48108106	4	8	1610	26	3	82	-	-	1,05
	48112106	3	12	1610	26	6,5	-	88	-	1,24
	48116106	3	16	1610	26	16	-	88	-	1,40
112	48108112	4	8	1610	26	3	90	-	-	1,25
	48112112	3	12	1610	26	6,5	-	88	-	1,47
	48116112	3	16	1610	26	16	-	88	-	1,70
118	48108118	4	8	1610	26	3	90	-	-	1,43
	48112118	3	12	2012	32	0,5	-	98	-	1,55
	48116118	3	16	2012	32	10	-	98	-	1,79
125	48108125	4	8	1610	26	3	90	-	-	1,64
	48112125	3	12	2012	32	0,5	-	98	-	1,90
	48116125	3	16	2012	32	10	-	98	-	2,18
132	48108132	4	8	1610	26	3	90	-	-	1,88
	48112132	3	12	2012	32	0,5	-	98	-	2,21
	48116132	3	16	2012	32	10	-	98	-	2,60
140	48108140	4	8	1610	26	3	90	-	-	1,60
	48112140	4	12	2517	45	12,5	120	-	-	7,10
	48116140	4	16	2517	45	3	120	-	-	9,60
160	48108160	5	8	2012	32	4,5	110	-	-	3,01
	48112160	4	12	2517	45	12,5	120	-	-	3,80
	48116160	4	16	2517	45	3	120	-	-	4,37
180	48108180	5	8	2012	32	4,5	110	-	-	3,92
	48112180	5	12	2517	45	6,25	120	-	-	5,03
	48116180	5	16	2517	45	1,5	120	-	-	5,97
200	48108200	5	8	2012	32	4,5	110	-	-	4,88
	48112200	5	12	2517	45	6,25	120	-	-	6,40
	48116200	5	16	2517	45	1,5	120	-	-	7,75
224	48108224	5	8	2012	32	4,5	110	-	-	6,17
	48112224	5	12	2517	45	6,25	120	-	-	8,29
	48116224	5	16	2517	45	1,5	120	-	-	10,10
250	48108250	5	8	2012	32	4,5	110	-	-	7,73
	48112250	5	12	2517	45	6,25	120	-	-	7,95
	48116250	5	16	2517	45	1,5	120	-	-	8,20



PPV-L TYPE

pitch $4,70 \pm 0,050$

N° GROOVES

F±0.1

8	48	7.55
12	67	7.65
16	86	7.75

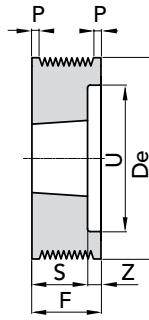

EXEC. 3

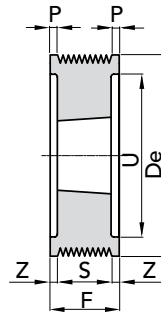

EXEC. 6

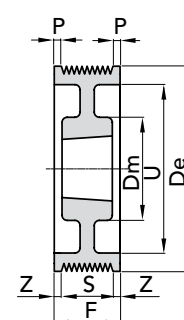

EXEC. 7

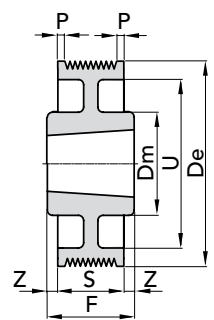

EXEC. 8

De	P. NUMBER	EXEC.	N° GROOVES	BUSHE	S	Z	Dm	U	WEIGHT Kg.
75	48208075	3	8	1210	26	22	-	56	0,66
	48212075	3	12	1215	42	25	-	56	0,97
80	48208080	3	8	1210	26	22	-	56	0,86
	48212080	3	12	1215	42	25	-	56	1,25
85	48208085	3	8	1210	26	22	-	61	1,00
	48212085	3	12	1215	42	25	-	61	1,47
	48216085	6	16	1215	42	22	-	61	1,76
90	48208090	3	8	1610	26	22	-	66	1,01
	48212090	3	12	1615	42	25	-	66	1,45
	48216090	6	16	1615	42	22	-	66	1,78
95	48208095	3	8	1610	26	22	-	71	1,16
	48212095	3	12	1615	42	25	-	71	1,71
	48216095	6	16	1615	42	22	-	71	2,02
100	48208100	3	8	1610	26	22	-	76	1,31
	48212100	3	12	2012	32	35	-	79	1,39
	48216100	6	16	2012	32	27	-	79	1,69
106	48208106	3	8	1610	26	22	-	82	1,53
	48212106	3	12	2012	32	35	-	82	1,76
	48216106	6	16	2012	32	27	-	82	2,12
112	48208112	3	8	1610	26	22	-	88	1,75
	48212112	3	12	2012	32	35	-	88	2,02
	48216112	6	16	2012	32	27	-	88	2,42
118	48208118	3	8	2012	32	16	-	94	1,88
	48212118	6	12	2517	45	11	-	97	1,96
	48216118	6	16	2517	45	20,5	-	97	2,31
125	48208125	3	8	2012	32	16	-	101	2,22
	48212125	6	12	2517	45	11	-	101	2,46
	48216125	6	16	2517	45	20,5	-	101	2,92
132	48208132	3	8	2012	32	16	-	108	2,54
	48212132	6	12	2517	45	11	-	108	2,97
	48216132	6	16	2517	45	20,5	-	108	3,44

De	P. NUMBER	EXEC.	N° GROOVES	BUSHE	S	Z	Dm	U	WEIGHT Kg.
140	48208140	3	8	2517	45	3	82	116	3,02
	48212140	6	12	2517	45	11	-	116	3,55
	48216140	6	16	2517	45	20,5	-	116	4,05
150	48208150	3	8	2517	45	3	-	126	3,75
	48212150	6	12	2517	45	11	-	126	4,30
	48216150	6	16	2517	45	20,5	-	126	4,85
160	48208160	3	8	2517	45	3	-	136	4,54
	48212160	6	12	2517	45	11	-	136	5,12
	48216160	6	16	3020	52	17	-	136	4,88
170	48208170	3	8	2517	45	3	-	146	5,35
	48212170	6	12	2517	45	11	-	146	6,03
	48216170	6	16	3020	52	17	-	146	5,96
180	48208180	7	8	2517	45	1,5	120	156	4,52
	48212180	7	12	2517	45	11	120	156	5,34
	48216180	6	16	3020	52	17	-	156	7,09
200	48208200	7	8	2517	45	1,5	120	176	5,07
	48212200	7	12	3020	52	7,5	146	176	6,99
	48216200	7	16	3020	52	17	146	176	7,92
224	48208224	7	8	2517	45	1,5	120	202	9,77
	48212224	7	12	3020	52	7,5	146	202	11,0
	48216224	7	16	3020	52	17	146	202	14,12
250	48208250	8	8	3020	52	2	146	228	13,12
	48212250	7	12	3020	52	7,5	146	228	15,60
	48216250	8	16	3535	89	1,5	178	228	16,13
280	48208280	8	8	3020	52	2	146	256	18,18
	48212280	7	12	3020	52	7,5	146	256	21,75
	48216280	8	16	3535	89	1,5	178	256	24,45
315	48208315	8	8	3020	52	2	146	285	24,82
	48212315	8	12	3535	89	11	178	285	42,64
	48216315	8	16	3535	89	1,5	178	285	35,34

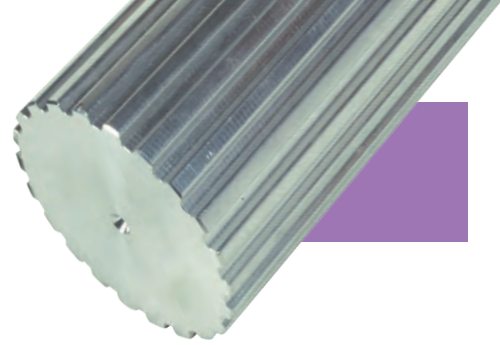

TIMING BARS

POLY CHAIN GT[®] TIMING BARS 8M - 14M	page	4
TIMING BARS FOR POSITIVE BELTS MXL - XL - L		5
HTD[®] TIMING BARS 5M - 8M		8
METRIC TIMING BARS FOR METRIC BELTS "T" 2.5 - 5 - 10		10
METRIC TIMING BARS "CT" FOR METRIC BELTS "AT" 5 - 10		13

FLANGES FOR PULLEYS

FLANGES FOR PULLEYS	17
FLANGES SIZES	
Thickness 0,5 mm	18
Thickness 1 mm	18
Thickness 1,5 mm	19
Thickness 2,5 mm	19

CLAMPING BELTS PLATES

PLATE FOR TIMING BELT POWERGRIP[®] POSITIVE	24
PLATE FOR TIMING BELT POWERGRIP[®] HTD[®]	25
PLATE FOR TIMING BELT METRIC PITCH "T"	26
PLATE FOR TIMING BELT METRIC PITCH "AT"	27



TIMING BELT BARS

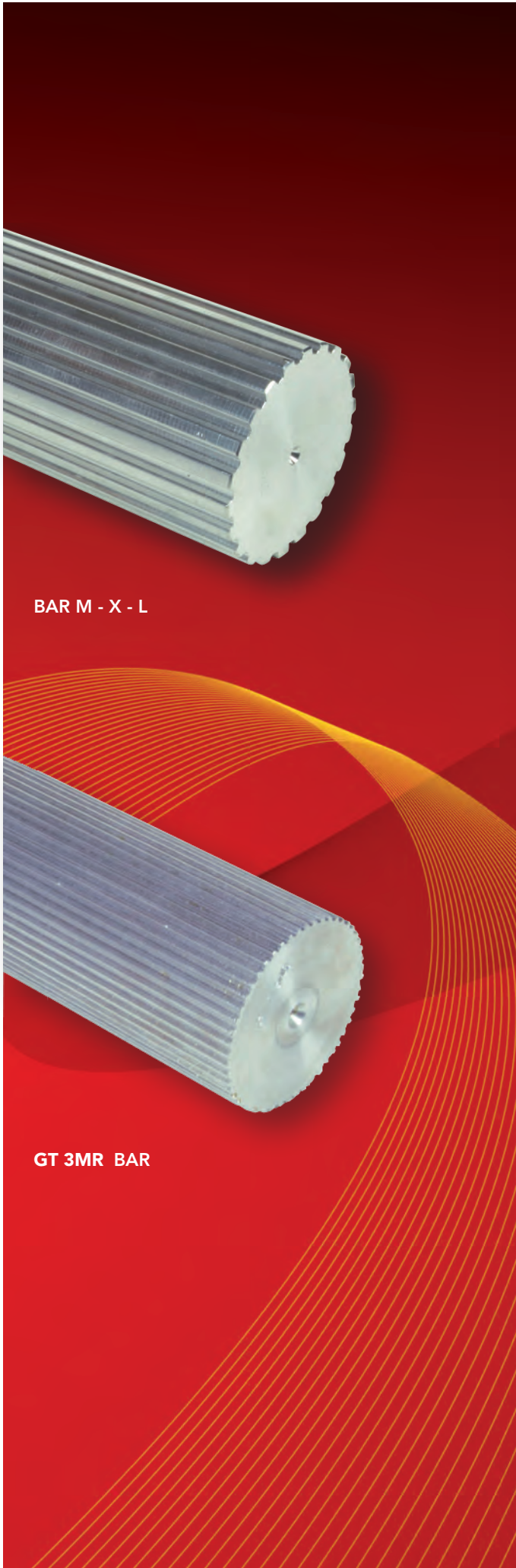

BAR M - X - L

GT 3MR BAR

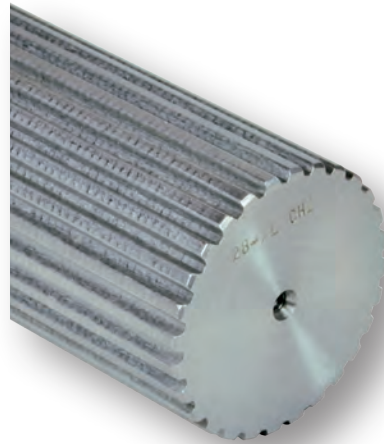

BAR XL

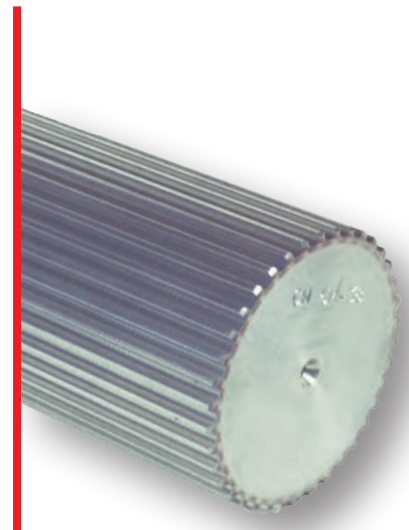

HTD BAR



GT 5MR BAR



TIMING BELT BARS



GT BAR

METRIC BAR CT

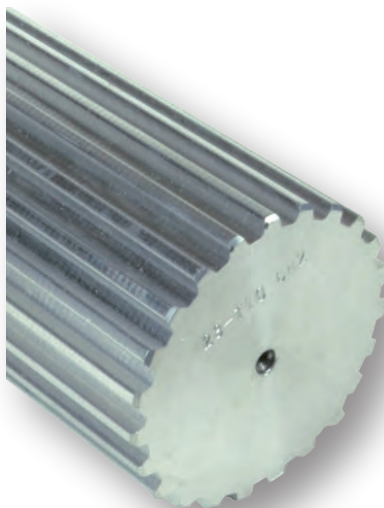

METRIC BAR T



TIMING BARS MXL 0.080"

MXL 0.080" (2.032 mm)

The **MXL** bars are built in **Aluminium** suitable for the hard oxidation thickness.

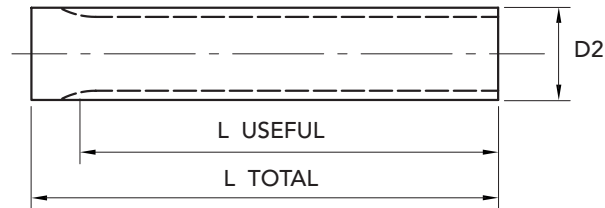

TIMING BARS MXL 0.080" (2.032 mm)

TYPE	PART NUMBER	N. TEETH	De EXTERNAL	L USEFUL	L TOTAL	WEIGHT Kg.
MXL 12	42023012	12	7,26	50	75	0,01
MXL 14	42023014	14	8,56	50	75	0,01
MXL 15	42023015	15	9,19	50	75	0,01
MXL 16	42023016	16	9,83	50	75	0,02
MXL 18	42023018	18	11,12	50	75	0,02
MXL 20	42023020	20	12,42	90	120	0,04
MXL 22	42023022	22	13,72	125	140	0,05
MXL 24	42023024	24	15,01	125	140	0,06
MXL 25	42023025	25	15,67	125	140	0,07
MXL 26	42023026	26	16,31	125	140	0,08
MXL 28	42023028	28	17,60	125	140	0,09
MXL 30	42023030	30	18,90	125	140	0,10
MXL 32	42023032	32	20,19	125	140	0,12
MXL 34	42023034	34	21,49	125	140	0,13
MXL 36	42023036	36	22,78	132	140	0,15
MXL 38	42023038	38	24,09	132	140	0,17
MXL 40	42023040	40	25,37	132	140	0,19
MXL 42	42023042	42	26,67	140	140	0,20
MXL 44	42023044	44	27,94	140	140	0,23
MXL 45	42023045	45	28,60	140	140	0,24
MXL 48	42023048	48	30,53	140	140	0,27
MXL 50	42023050	50	31,83	140	140	0,30
MXL 60	42023060	60	38,30	160	160	0,49
MXL 70	42023070	70	44,78	160	160	0,67
MXL 72	42023072	72	46,05	160	160	0,72

MATERIAL **ALUMINIUM**

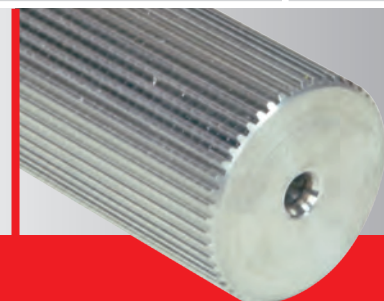

CAD drawings available on our site
www.chiaravalli.com

Quantity, availability and prices
on B2B Chiaravalli



XL 1/5" (5.08 mm)

The **XL** bars are built in **Steel** and **Aluminium** suitable for the hard oxidation thickness.

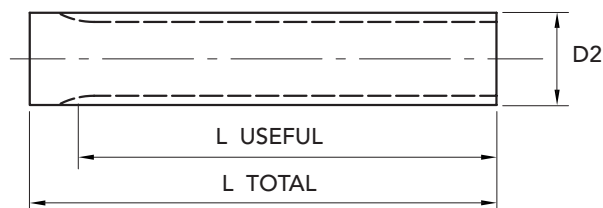

TYPE	PART NUMBER STEEL	PART NUMBER ALUMINIUM	N. TEETH	De EXTERNAL	L USEFUL	L TOTAL	ALUMINIUM WEIGHT Kg.	STEEL WEIGHT Kg.
XL 10	42000010	42003010	10	15,66	125	140	0,07	0,84
XL 11	42000011	42003011	11	17,28	125	140	0,08	0,92
XL 12	42000012	42003012	12	18,90	125	140	0,10	1,20
XL 13	42000013	42003013	13	20,51	125	140	0,11	1,08
XL 14	42000014	42003014	14	22,13	132	140	0,13	1,12
XL 15	42000015	42003015	15	23,75	132	140	0,16	1,44
XL 16	42000016	42003016	16	25,36	140	140	0,18	1,27
XL 17	42000017	42003017	17	26,98	140	140	0,20	1,31
XL 18	42000018	42003018	18	28,60	140	140	0,23	1,51
XL 19	42000019	42003019	19	30,22	140	140	0,26	1,70
XL 20	42000020	42003020	20	31,83	140	140	0,28	1,60
XL 21	42000021	42003021	21	33,45	160	160	0,36	2,06
XL 22	42000022	42003022	22	35,07	160	160	0,40	2,12
XL 23	42000023	42003023	23	36,60	160	160	0,44	2,32
XL 24	42000024	42003024	24	38,30	160	160	0,48	2,41
XL 25	42000025	42003025	25	39,93	160	160	0,51	2,75
XL 26	42000026	42003026	26	41,53	160	160	0,56	2,79
XL 27	42000027	42003027	27	43,15	160	160	0,60	3,90
XL 28	42000028	42003028	28	44,77	160	160	0,65	3,41
XL 29	42000029	42003029	29	46,39	160	160	0,70	3,42
XL 30	42000030	42003030	30	48,00	160	160	0,75	3,78
XL 32	42000032	42003032	32	51,24	160	160	0,87	3,93
XL 33	42000033	42003033	33	52,76	160	160	0,92	4,00
XL 34	42000034	42003034	34	54,47	160	160	0,98	4,48
XL 35	42000035	42003035	35	56,09	160	160	1,04	4,50
XL 36	42000036	42003036	36	57,7	160	160	1,1	4,60
XL 38	42000038	42003038	38	60,94	160	160	1,23	5,15
XL 39	42000039	42003039	39	62,56	160	160	1,3	5,20
XL 40	42000040	42003040	40	64,17	160	160	1,37	5,75
XL 41	42000041	42003041	41	65,79	160	160	1,43	6,00
XL 42	42000042	42003042	42	67,41	160	160	1,51	6,10
XL 43	42000043	42003043	43	69,02	160	160	1,58	6,50
XL 44	42000044	42003044	44	70,64	160	160	1,65	6,60
XL 48	42000048	42003048	48	77,11	160	160	1,98	7,57
XL 56	42000056	42003056	56	90,04	160	160	2,71	10,66
XL 60	42000060	42003060	60	96,51	160	160	3,1	10,90
XL 72	42000072	42003072	72	115,92	160	160	4,52	15,20

MATERIAL **STEEL C40
UNI 7845**

ALUMINIUM

CAD drawings available on our site
www.chiaravalli.com

Quantity, availability and prices
on B2B Chiaravalli





TIMING BARS L 3/8"

L 3/8" (9.525 mm)

The L bars are built in **Steel** and **Aluminium** suitable for the hard oxidation thickness.

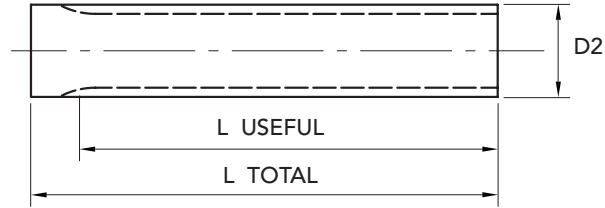

TIMING BARS L 3/8" (9.525 mm)

TYPE	PART NUMBER STEEL	PART NUMBER ALUMINIUM	N. TEETH	De EXTERNAL	L USEFUL	L TOTAL	STEEL WEIGHT Kg.	ALUMINIUM WEIGHT Kg.
L 10	42010010	42013010	10	29,56	140	140	0,66	0,23
L 11	42010011	42013011	11	32,59	140	140	0,81	0,28
L 12	42010012	42013012	12	35,62	160	160	1,12	0,39
L 13	42010013	42013013	13	38,65	160	160	1,32	0,46
L 14	42010014	42013014	14	41,68	160	160	1,57	0,55
L 15	42010015	42013015	15	44,72	160	160	1,81	0,63
L 16	42010016	42013016	16	47,75	160	160	2,08	0,73
L 17	42010017	42013017	17	50,78	160	160	2,34	0,82
L 18	42010018	42013018	18	53,81	160	160	2,64	0,93
L 19	42010019	42013019	19	56,84	160	160	2,96	1,04
L 20	42010020	42013020	20	59,88	160	160	3,32	1,16
L 21	42010021	42013021	21	62,91	160	160	3,67	1,28
L 22	42010022	42013022	22	65,94	160	160	4,07	1,41
L 23	42010023	42013023	23	68,97	160	160	4,44	1,55
L 24	42010024	42013024	24	72,00	160	160	4,86	1,69
L 27	42010027	42013027	27	81,10	160	160	6,20	2,15
L 30	42010030	42013030	30	90,20	160	160	7,72	2,67

MATERIAL **STEEL C40 UNI 7845**

ALUMINIUM

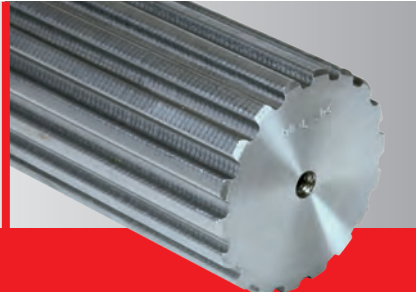

CAD drawings available on our site www.chiaravalli.com

Quantity, availability and prices on B2B Chiaravalli



HTD® 5M (Pitch 5 mm)

Aluminium material suitable for the hard oxidation.

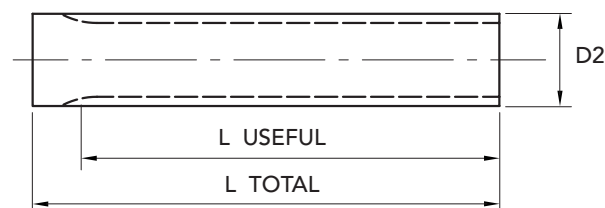

TYPE	PART NUMBER	N. TEETH	Dp	De EXTERNAL	L USEFUL	L TOTAL	WEIGHT Kg.
5M- 12	40200012	12	19,10	17,96	150	160	0,08
5M- 13	40200013	13	20,69	19,55	150	160	0,10
5M- 14	40200014	14	22,28	21,14	175	200	0,16
5M- 15	40200015	15	23,87	22,73	175	200	0,19
5M- 16	40200016	16	25,47	24,33	175	200	0,21
5M- 17	40200017	17	27,06	25,92	175	200	0,24
5M- 18	40200018	18	28,65	27,51	200	200	0,27
5M- 19	40200019	19	30,24	29,1	200	200	0,31
5M- 20	40200020	20	31,83	30,69	200	200	0,35
5M- 21	40200021	21	33,42	32,28	200	200	0,39
5M- 22	40200022	22	35,02	33,88	200	200	0,43
5M- 23	40200023	23	36,61	35,47	200	200	0,48
5M- 24	40200024	24	38,20	37,06	200	200	0,52
5M- 25	40200025	25	39,79	38,65	200	200	0,57
5M- 26	40200026	26	41,38	40,24	200	200	0,62
5M- 27	40200027	27	42,97	41,83	200	200	0,67
5M- 28	40200028	28	44,56	43,42	200	200	0,73
5M- 30	40200030	30	47,75	46,61	200	200	0,84
5M- 32	40200032	32	50,93	49,79	200	200	0,97
5M- 34	40200034	34	54,11	52,97	200	200	1,11
5M- 36	40200036	36	57,30	56,16	200	200	1,25
5M- 38	40200038	38	60,48	59,34	200	200	1,40
5M- 40	40200040	40	63,66	62,52	200	200	1,55
5M- 42	40200042	42	66,85	65,71	200	200	1,73
5M- 44	40200044	44	70,03	68,89	200	200	1,90
5M- 45	40200045	45	71,62	70,48	200	200	1,99
5M- 48	40200048	48	76,40	75,26	200	200	2,27
5M- 50	40200050	50	79,58	78,44	200	200	2,48
5M- 60	40200060	60	95,5	94,36	200	200	3,60
5M- 72	40200072	72	114,59	113,45	200	200	5,28

MATERIAL **ALUMINIUM**

CAD drawings available on our site
www.chiaravalli.com

Quantity, availability and prices
 on B2B Chiaravalli

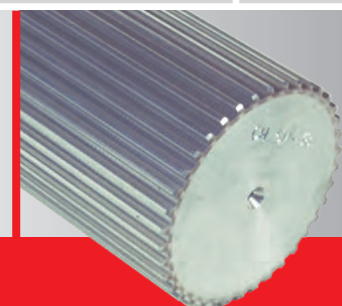



HTD® 8M (Pitch 8 mm)

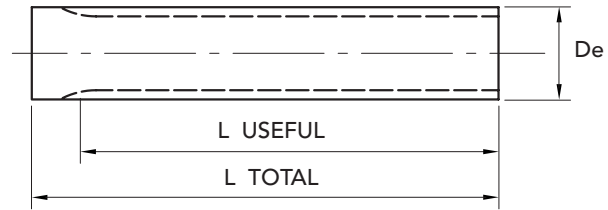

HTD® 8M TIMING BARS (pitch 8 mm)

TYPE	PART NUMBER	N. TEETH	De Ø PITCH	De EXTERNAL	L USEFUL	L TOTAL	WEIGHT Kg.
8M- 18	40400018	18	45,84	44,47	200	200	2,03
8M- 19	40400019	19	48,38	47,01	200	200	2,30
8M- 20	40400020	20	50,93	49,56	200	200	2,57
8M- 21	40400021	21	53,48	52,11	200	200	2,88
8M- 22	40400022	22	56,02	54,65	200	200	3,18
8M- 23	40400023	23	58,57	57,20	200	200	3,52
8M- 24	40400024	24	61,12	59,75	200	200	3,86
8M- 25	40400025	25	63,66	62,29	200	200	4,23
8M- 26	40400026	26	66,21	64,84	200	200	4,60
8M- 28	40400028	28	71,30	69,93	200	200	5,40
8M- 30	40400030	30	76,40	75,03	200	200	6,27
8M- 32	40400032	32	81,49	80,12	200	200	7,20
8M- 34	40400034	34	86,58	85,21	200	200	8,20
8M- 35	40400035	35	89,13	87,76	200	200	8,71
8M- 36	40400036	36	91,68	90,31	200	200	9,26
8M- 38	40400038	38	96,77	95,40	200	200	19,39
8M- 40	40400040	40	101,86	100,49	200	200	11,58
8M- 44	40400044	44	112,05	110,67	200	200	14,16
8M- 48	40400048	48	122,23	120,86	200	200	16,99

MATERIAL **STEEL C40**
UNI 7845

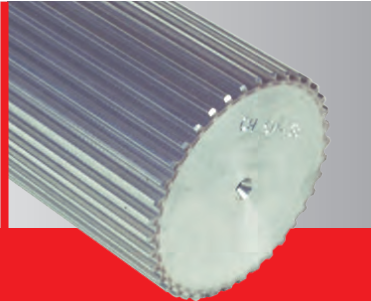

CAD drawings available on our site
www.chiaravalli.com

Quantity, availability and prices
on B2B Chiaravalli



T 2.5 (Pitch 2.5 mm)

The T 2.5 bars are built in **Aluminium** suitable for the hard oxidation thickness.

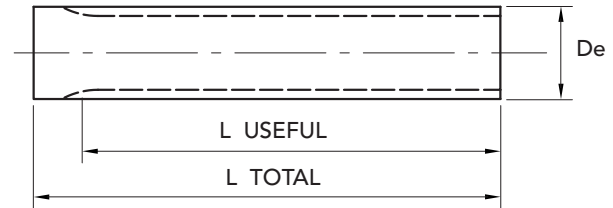

TYPE	PART NUMBER	N. TEETH	De EXTERNAL	L USEFUL	L TOTAL	WEIGHT Kg.
T 2,5- 10	45020010	10	7,45	50	75	0,01
T 2,5- 12	45020012	12	9,00	50	75	0,01
T 2,5- 13	45020013	13	9,80	50	75	0,02
T 2,5- 14	45020014	14	10,60	50	75	0,02
T 2,5- 15	45020015	15	11,40	50	75	0,02
T 2,5- 16	45020016	16	12,20	50	75	0,03
T 2,5- 17	45020017	17	13,00	50	75	0,03
T 2,5- 18	45020018	18	13,80	50	75	0,03
T 2,5- 19	45020019	19	14,60	90	120	0,05
T 2,5- 20	45020020	20	15,40	90	120	0,06
T 2,5- 21	45020021	21	16,20	90	120	0,06
T 2,5- 22	45020022	22	17,00	125	140	0,08
T 2,5- 24	45020024	24	18,55	125	140	0,09
T 2,5- 26	45020026	26	20,15	125	140	0,10
T 2,5- 27	45020027	27	20,95	125	140	0,12
T 2,5- 28	45020028	28	21,75	125	140	0,13
T 2,5- 29	45020029	29	22,55	125	140	0,14
T 2,5- 30	45020030	30	23,35	125	140	0,16
T 2,5- 32	45020032	32	24,95	125	140	0,18
T 2,5- 34	45020034	34	26,55	125	140	0,20
T 2,5- 35	45020035	35	27,35	132	140	0,20
T 2,5- 36	45020036	36	28,10	132	140	0,22
T 2,5- 38	45020038	38	29,70	140	140	0,25
T 2,5- 40	45020040	40	31,30	140	140	0,28
T 2,5- 42	45020042	42	32,90	140	140	0,31
T 2,5- 44	45020044	44	34,50	140	140	0,34
T 2,5- 45	45020045	45	35,30	140	140	0,36
T 2,5- 48	45020048	48	37,70	140	140	0,41
T 2,5- 50	45020050	50	39,29	160	160	0,51
T 2,5- 60	45020060	60	47,25	160	160	0,74
T 2,5- 65	45020065	65	51,20	160	160	0,90
T 2,5- 70	45020070	70	55,20	160	160	1,01
T 2,5- 72	45020072	72	56,80	160	160	1,07
T 2,5- 90	45020090	90	71,12	160	160	1,64
T 2,5- 100	45020100	100	79,08	160	160	2,09

MATERIAL **ALUMINIUM**

ON REQUEST T 20
bars are available.

CAD drawings available on our site
www.chiaravalli.com

Quantity, availability and prices
on B2B Chiaravalli

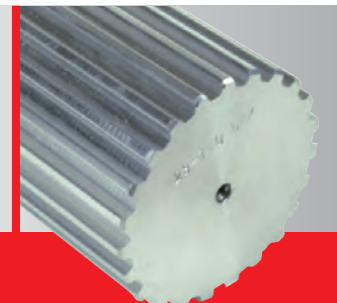



METRIC TIMING BARS FOR METRIC BELTS "T" 5

11

T 5 (Pitch 5 mm)

The T5 bars are built in **Aluminium** suitable for the hard oxidation thickness.

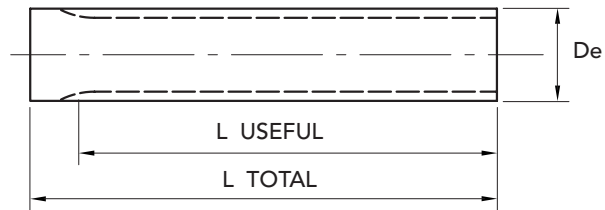

METRIC TIMING BARS FOR METRIC "T" 5 (Pitch 5 mm)

TYPE	PART NUMBER	N. TEETH	De EXTERNAL	L USEFUL	L TOTAL	WEIGHT Kg.
T 5- 10	45050010	10	15,05	125	140	0,07
T 5- 11	45050011	11	16,65	125	140	0,08
T 5- 12	45050012	12	18,25	125	140	0,10
T 5- 13	45050013	13	19,85	125	140	0,12
T 5- 14	45050014	14	21,45	140	140	0,13
T 5- 15	45050015	15	23,05	140	140	0,16
T 5- 16	45050016	16	24,60	140	140	0,18
T 5- 17	45050017	17	26,20	140	140	0,20
T 5- 18	45050018	18	27,00	140	140	0,22
T 5- 19	45050019	19	29,40	140	140	0,24
T 5- 20	45050020	20	31,00	160	160	0,31
T 5- 21	45050021	21	32,70	160	160	0,33
T 5- 22	45050022	22	34,15	160	160	0,36
T 5- 23	45050023	23	35,85	160	160	0,40
T 5- 24	45050024	24	37,40	160	160	0,44
T 5- 25	45050025	25	38,95	160	160	0,48
T 5- 26	45050026	26	40,60	160	160	0,53
T 5- 27	45050027	27	42,20	160	160	0,57
T 5- 28	45050028	28	43,75	160	160	0,61
T 5- 29	45050029	29	45,35	160	160	0,66
T 5- 30	45050030	30	46,95	160	160	0,69
T 5- 32	45050032	32	50,10	160	160	0,81
T 5- 34	45050034	34	53,25	160	160	0,91
T 5- 35	45050035	35	54,85	160	160	0,98
T 5- 36	45050036	36	56,45	160	160	1,04
T 5- 37	45050037	37	58,06	160	160	1,10
T 5- 38	45050038	38	59,65	160	160	1,17
T 5- 40	45050040	40	62,85	160	160	1,33
T 5- 42	45050042	42	66,00	160	160	1,43
T 5- 44	45050044	44	69,20	160	160	1,58
T 5- 45	45050045	45	70,80	160	160	1,65
T 5- 46	45050046	46	72,40	160	160	1,72
T 5- 48	45050048	48	75,55	160	160	1,88
T 5- 50	45050050	50	78,75	160	160	2,05
T 5- 60	45050060	60	94,65	160	160	3,00
T 5- 72	45050072	72	113,75	160	160	4,34
T 5- 80	45050080	80	126,48	160	160	5,38
T 5- 90	45050090	90	142,40	160	160	6,84
T 5- 100	45050100	100	158,31	160	160	8,46

MATERIAL **ALUMINIUM**

ON REQUEST T 20
bars are available.

CAD drawings available on our site
www.chiaravalli.com

Quantity, availability and prices
on B2B Chiaravalli





METRIC TIMING BARS FOR METRIC BELTS "T" 10

METRIC TIMING BARS FOR METRIC BELTS "T" 10 (Pitch 10 mm)

T 10 (Pitch 10 mm)

The T 10 bars are built in **Aluminium** suitable for the hard oxidation thickness.

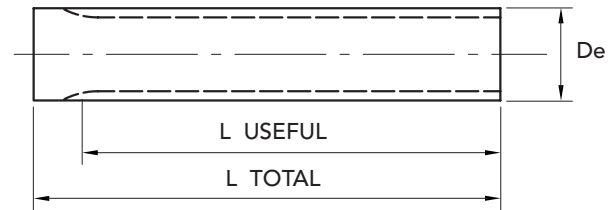

TYPE	PART NUMBER	N. TEETH	De EXTERNAL	L USEFUL	L TOTAL	WEIGHT Kg.
T 10- 10	45100010	10	29,98	140	140	0,23
T 10- 11	45100011	11	33,16	140	140	0,29
T 10- 12	45100012	12	36,35	140	140	0,35
T 10- 13	45100013	13	39,55	140	140	0,42
T 10- 14	45100014	14	42,70	160	160	0,56
T 10- 15	45100015	15	45,90	160	160	0,66
T 10- 16	45100016	16	49,10	160	160	0,76
T 10- 17	45100017	17	52,25	160	160	0,86
T 10- 18	45100018	18	55,45	160	160	0,99
T 10- 19	45100019	19	58,65	160	160	1,10
T 10- 20	45100020	20	61,80	160	160	1,22
T 10- 21	45100021	21	65,00	160	160	1,32
T 10- 22	45100022	22	68,15	160	160	1,45
T 10- 23	45100023	23	71,35	160	160	1,60
T 10- 24	45100024	24	74,55	160	160	1,76
T 10- 26	45100026	26	80,90	160	160	2,08
T 10- 28	45100028	28	87,25	160	160	2,44
T 10- 30	45100030	30	93,65	160	160	2,84
T 10- 32	45100032	32	100,00	160	160	3,25
T 10- 34	45100034	34	106,40	160	160	3,69
T 10- 36	45100036	36	112,75	160	160	4,15
T 10- 38	45100038	38	119,10	160	160	4,62
T 10- 40	45100040	40	125,45	160	160	5,15
T 10- 45	45100045	45	141,40	160	160	6,59
T 10- 48	45100048	48	150,95	160	160	7,55
T 10- 60	45100060	60	189,15	160	160	11,78
T 10- 72	45100072	72	227,29	160	160	17,16

MATERIAL **ALUMINIUM**

ON REQUEST T 20
bars are available.

CAD drawings available on our site
www.chiaravalli.com

Quantity, availability and prices
on B2B Chiaravalli

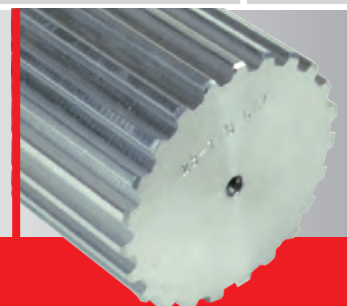



CT 5 (Pitch 5 mm)

The CT 5 bars are built in **Aluminium** suitable for the hard oxidation thickness.

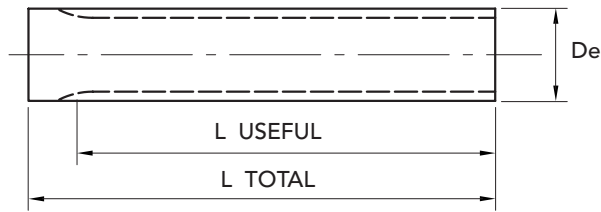

METRIC TIMING BARS FOR METRIC BELTS "AT" 5 (Pitch 5 mm)

TYPE	PART NUMBER	N. TEETH	De EXTERNAL	L USEFUL	L TOTAL	WEIGHT Kg.
CT5- 12	46050012	12	17,85	140	140	0,08
CT5- 13	46050013	13	19,45	140	140	0,10
CT5- 14	46050014	14	21,05	140	140	0,12
CT5- 15	46050015	15	22,65	140	140	0,14
CT5- 16	46050016	16	24,20	140	140	0,15
CT5- 18	46050018	18	27,40	140	140	0,20
CT5- 19	46050019	19	29,00	140	140	0,23
CT5- 20	46050020	20	30,60	160	160	0,30
CT5- 21	46050021	21	32,30	160	160	0,33
CT5- 22	46050022	22	33,85	160	160	0,36
CT5- 23	46050023	23	35,45	160	160	0,40
CT5- 24	46050024	24	37,00	160	160	0,44
CT5- 25	46050025	25	38,55	160	160	0,47
CT5- 26	46050026	26	40,20	160	160	0,51
CT5- 28	46050028	28	43,25	160	160	0,60
CT5- 30	46050030	30	46,55	160	160	0,69
CT5- 32	46050032	32	49,70	160	160	0,81
CT5- 34	46050034	34	52,85	160	160	0,90
CT5- 36	46050036	36	56,05	160	160	1,02
CT5- 38	46050038	38	59,25	160	160	1,14
CT5- 40	46050040	40	62,45	160	160	1,28
CT5- 42	46050042	42	65,60	160	160	1,41
CT5- 44	46050044	44	68,80	160	160	1,55
CT5- 46	46050046	46	72,00	160	160	1,70
CT5- 48	46050048	48	75,15	160	160	1,85
CT5- 52	46050052	52	81,55	160	160	2,19
CT5- 56	46050056	56	87,90	160	160	2,55
CT5- 60	46050060	60	94,25	160	160	2,94
CT5- 64	46050064	64	100,65	160	160	3,36
CT5- 72	46050072	72	113,35	160	160	4,29

MATERIAL **ALUMINIUM**

ON REQUEST T 20
bars are available.

CAD drawings available on our site
www.chiaravalli.com

Quantity, availability and prices
on B2B Chiaravalli

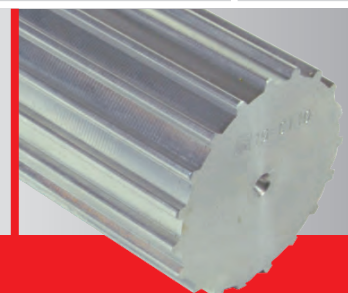



METRIC TIMING BARS FOR METRIC BELTS "AT" 10

METRIC TIMING BARS FOR METRIC BELTS "AT" 10 (Pitch 10 mm)

CT 10 (Pitch 10 mm)

The CT 10 bars are built in **Aluminium** suitable for the hard oxidation thickness.

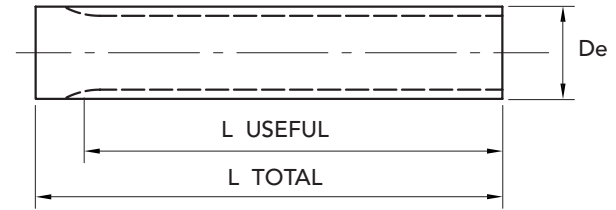

TYPE	PART NUMBER	N. TEETH	De EXTERNAL	L USEFUL	L TOTAL	WEIGHT Kg.
CT10- 15	46100015	15	45,90	160	160	0,62
CT10- 16	46100016	16	49,14	160	160	0,72
CT10- 18	46100018	18	55,45	160	160	0,92
CT10- 19	46100019	19	58,65	160	160	1,05
CT10- 20	46100020	20	61,80	160	160	1,17
CT10- 21	46100021	21	65,00	160	160	1,31
CT10- 22	46100022	22	68,20	160	160	1,44
CT10- 23	46100023	23	71,35	160	160	1,60
CT10- 24	46100024	24	74,55	160	160	1,75
CT10- 25	46100025	25	77,75	160	160	1,91
CT10- 26	46100026	26	80,90	160	160	2,06
CT10- 28	46100028	28	87,25	160	160	2,42
CT10- 30	46100030	30	93,65	160	160	2,79
CT10- 32	46100032	32	100,00	160	160	3,20
CT10- 34	46100034	34	106,40	160	160	3,65
CT10- 36	46100036	36	112,75	160	160	4,09
CT10- 38	46100038	38	119,10	160	160	4,59
CT10- 40	46100040	40	125,45	160	160	5,16
CT10- 42	46100042	42	131,85	160	160	5,65
CT10- 44	46100044	44	138,20	160	160	6,22
CT10- 46	46100046	46	144,55	160	160	6,84
CT10- 48	46100048	48	150,95	160	160	7,45
CT10- 52	46100052	52	163,65	160	160	8,93
CT10- 56	46100056	56	176,40	160	160	10,39
CT10- 60	46100060	60	189,15	160	160	11,78

MATERIAL **ALUMINIUM**

ON REQUEST T 20
bars are available.

CAD drawings available on our site
www.chiaravalli.com

Quantity, availability and prices
on B2B Chiaravalli

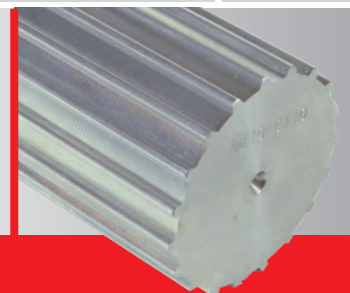



FLANGES FOR PULLEYS

FLANGES FOR PULLEYS

page 17

FLANGES SIZES

Thickness **0,5 mm**

18

Thickness **1 mm**

18

Thickness **1,5 mm**

19

Thickness **2,5 mm**

19



FLANGES FOR PULLEYS

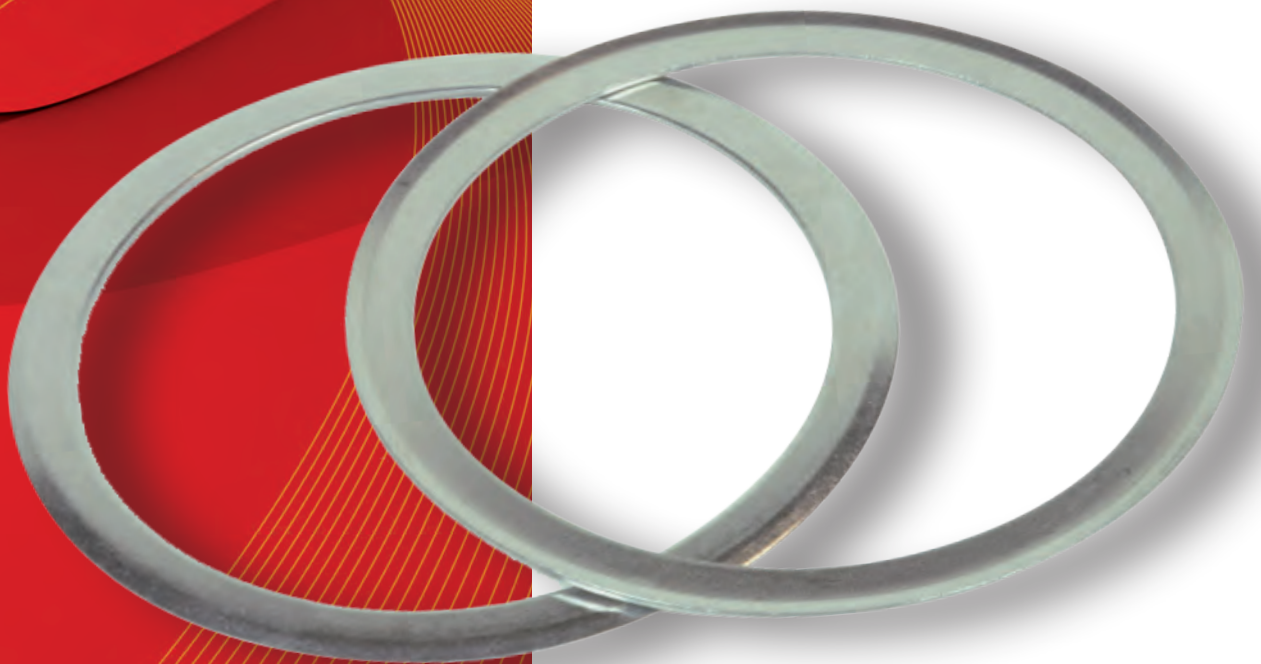
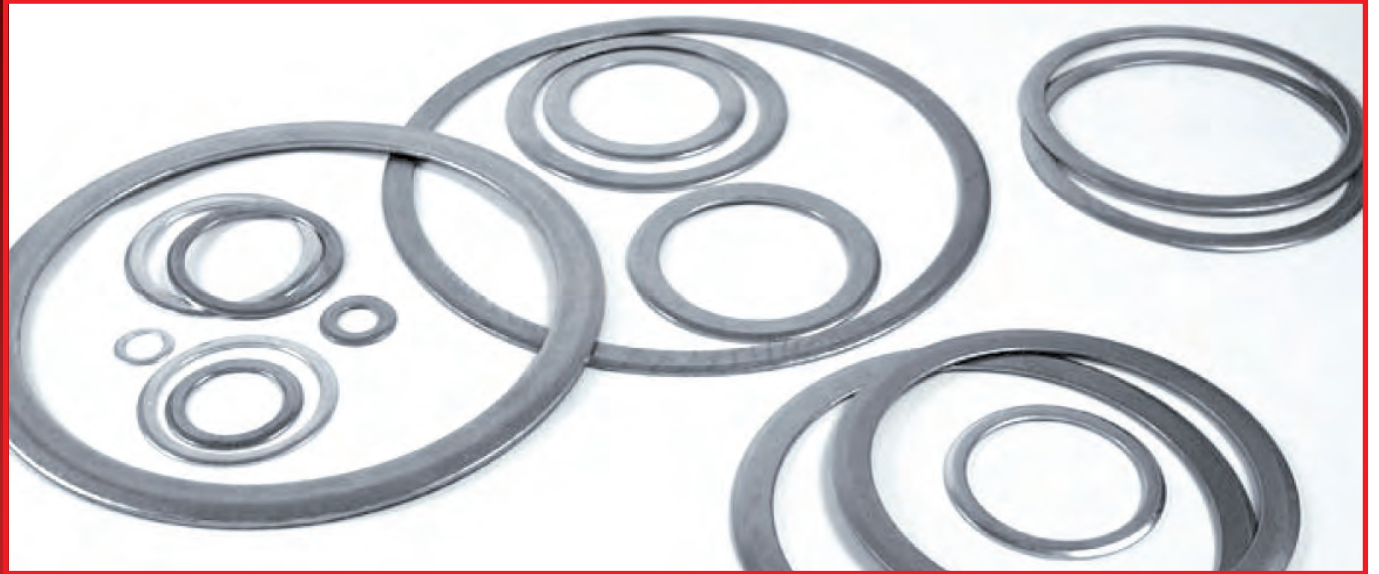

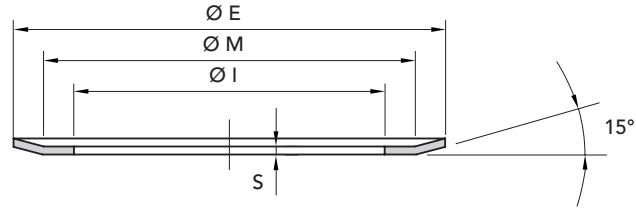

TYPE PULLEYS

No TEETH PULLEY	MXL	XL	L	H	XH	XXH	GT 3MR HTD 3M	GT 5MR HTD 5M	HTD 8M	HTD 14M	PC GT 8M	PC GT 14M	T 2,5	CT 5 T 5	CT 10 T 10
N. FLANGE															
10		1	50				501							3	7
11		1	50											1	9
12		2	52				502	14					501	1	13
13		2	83										501	2	12
14		4	54	59			503	2					502	2	11
15		4	55	60			516	4					502	4	16
16	502	5	56	61			504	4					503	5	18
17		6	57	62									503	5	20
18	503	7	58	63	155	163	505	6					504	6	21
19		7	59	64	156								505	8	24
20	503	9	60	76	157	165	517	8					505	8	24
21		9	61	66	158		518	9					505	9	26
22	504	10	62	67	159	169	518	15	53		53		512	9	27
23		13	63	68									512	10	27
24	505	12	63	70	161	173	518	13	69				512	13	29
25		12	64	71	162						61		506	12	29
26		11	65	72	163	178	508	12	61				507	12	31
27		11	65	74	164								507	11	32
28	506	16	66	75	165		509	11	79	153	79	153	507	11	33
29		16		75									507	16	
30	506	18	68	78	167		509	16	73	154	82	154	508	16	35
32	507	20	70	80	169		510	18	76	160	76	160	509	18	38
33			71	81									509		
34		22	72	81	170			20	66	166	66	171	509	21	72
35		22	72	85									509	22	
36	508	23	74	85			519	21	68	168	68	168	510	23	43
37													510	23	
38		24		86				24	70	172	70	172	510	24	78
39		24													
40	509	26	78	90			513	25	77	162	77	174	511	24	47
41		26													
42	509	27	80	94									511	26	
43		27													
44	510	27	81	95			520	27	75	175		175	513	27	
45			81	96							75			27	85
46														29	
48		29	85	100				29	78	180	78	180	513	29	86
50											80	169	514	31	
56		35						33	85	182	85	182			
60		38									86		515	38	100
64								38	90	184	90				
72								43	97						





FLANGES SIZES

FLANGES SIZES THICKNESS 0,5 mm - 1 mm

THICKNESS 0,5 mm - 1 mm

MATERIAL **FE ZINCPLATED**

MATERIAL **FE**

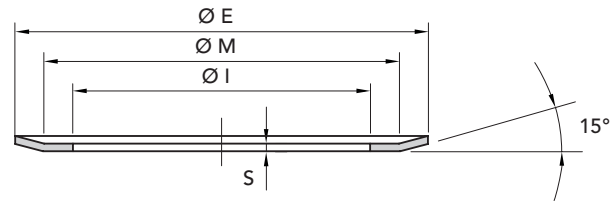

THICKNESS 0,5 mm

THICKNESS 1 mm

No FLANGE	PART NUMBER	Thickness S = 0,5 mm			Weight Kg.
		Ø E	Ø I	Ø M	
501	49200501	13	6	10	0,0004
502	49200502	15	8	12	0,0005
503	49200503	16	9,5	13	0,0005
504	49200504	17,5	11,6	14,5	0,0005
505	49200505	20	12,2	16,5	0,0008
506	49200506	25	14,5	21,5	0,001
507	49200507	26	17,8	24	0,001
508	49200508	28	20	25	0,001
509	49200509	32	23	27,5	0,001
510	49200510	36	25	31	0,002
511	49200511	38	26,5	34	0,002
512	49200512	22	14,5	19	0,0008
513	49200513	42	30,5	38	0,003
514	49200514	44	32,5	40,5	0,003
515	49200515	51	40	47	0,003
516	49200516	17,5	10,5	14,5	0,0006
517	49200517	23	14	20	0,001
518	49200518	25	15	21,5	0,001
519	49200519	39	28	34,5	0,002
520	49200520	48	37	43,5	0,003

No FLANGE	PART NUMBER	Thickness S = 1 mm			Weight Kg.
		Ø E	Ø I	Ø M	
1	49200001	23	12,5	18	0,003
2	49200002	25	15	21,5	0,003
3	49200003	19,5	12	17,5	0,002
4	49200004	28	17,8	24	0,003
5	49200005	32	20	26	0,004
6	49200006	32	23	27,5	0,003
7	49200007	35	23	30,5	0,004
8	49200008	36	25	31	0,004
9	49200009	38	26,5	34	0,005
10	49200010	41	30	36	0,005
11	49200011	48	37	43,5	0,006
12	49200012	44	32,5	40,5	0,006
13	49200013	42	30,5	38	0,005
14	49200014	23	14	20	0,002
15	49200015	39	28	34,5	0,004
16	49200016	51	40	47	0,006
17					
18	49200018	54	43	50,5	0,007
19					
20	49200020	57	47	51,5	0,006
21	49200021	60	47	57	0,008
22	49200022	61	49	56,5	0,008
23	49200023	64	47	57	0,012
24	49200024	66,5	52	63	0,011
25	49200025	71	56	64	0,012
26	49200026	70	53	66,5	0,012
27	49200027	75	60	68,5	0,012
28					
29	49200029	83	68	78	0,014
30					
31	49200031	87	72	82,5	0,014
32	49200032	91	76	85,5	0,016
33	49200033	93	80	89	0,014
34					
35	49200035	102	83	93,8	0,021
36					
37					
38	49200038	106	90	101	0,019
39					
40					
41					
42					
43	49200043	119	103	113,5	0,021
44					
45					
46					
47	49200047	131	115	125,5	0,024

CAD drawings available on our site
www.chiaravalli.com

Quantity, availability and prices
on B2B Chiaravalli



FLANGES SIZES

THICKNESS 1,5 mm - 2,5 mm

MATERIAL **FE**

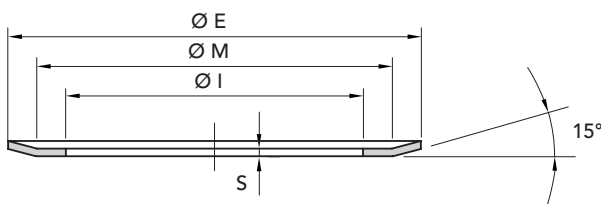

FLANGES SIZES THICKNESS 1,5 mm - 2,5 mm

THICKNESS 1,5 mm					
No FLANGE	PART NUMBER	Thickness S = 1,5 mm			Weight Kg.
		Ø E	Ø I	Ø M	
50	49200050	37	25	33	0,007
51	49200051	39	28	34,5	0,007
52	49200052	43	31	39	0,008
53	49200053	60	47	57	0,013
54	49200054	48	37	42	0,009
55	49200055	51	38,5	45	0,020
56	49200056	54	43	48	0,009
57	49200057	57	46	51	0,020
58	49200058	60	48	54,2	0,011
59	49200059	64	47	57	0,017
60	49200060	66,5	53	60,2	0,014
61	49200061	70	53	64	0,019
62	49200062	75	57	68	0,021
63	49200063	79	60	72,5	0,024
64	49200064	82,5	64	76	0,024
65	49200065	86	68	81,5	0,025
66	49200066	91	73	86	0,028
67	49200067	94	76	88	0,028
68	49200068	97	79	92	0,029
69	49200069	66	52	61,5	0,015
70	49200070	102	82,5	97	0,033
71	49200071	106	86	100	0,034
72	49200072	112	91	105,5	0,038
73	49200073	83	68	76,5	0,021
74	49200074	115	94	109	0,039
75	49200075	120	99,5	112,5	0,041
76	49200076	87	72	82,5	0,021
77	49200077	106	90	101	0,027
78	49200078	128	107	121	0,045
79	49200079	75	60	70,5	0,018
80	49200080	135	115	128,5	0,046
81	49200081	142	120	137	0,051
82	49200082	82,5	67	76	0,021
83	49200083	44	32,5	40,5	0,008
84					
85	49200085	150	130	145	0,052
86	49200086	158	138,5	153	0,054
87					
88					
89					
90	49200090	168	148	161	0,058
91					
92					
93					
94	49200094	180	154	174	0,078
95	49200095	184	162	177	0,068
96	49200096	192	165	181,5	0,090
97	49200097	192	173	187	0,060
98					
99					
100	49200100	200	180	193	0,076

THICKNESS 2,5 mm					
No FLANGE	PART NUMBER	Thickness S = 2,5 mm			Weight Kg.
		Ø E	Ø I	Ø M	
150					
151					
152					
153	49200153	128	107	124	0,075
154	49200154	138	112	131	0,098
155	49200155	140	107	125	0,125
156	49200156	146	107	133	0,155
157	49200157	155	107	139	0,191
158	49200158	160	120	148	0,173
159	49200159	170	120	153	0,225
160	49200160	154	122	142	0,133
161	49200161	184	135	168	0,241
162	49200162	188	150	176	0,191
163	49200163	198	150	180	0,255
164	49200164	205	160	189	0,254
165	49200165	212	162	200	0,288
166	49200166	160	130	150	0,132
167	49200167	227	176	210	0,318
168	49200168	168	135	162	0,154
169	49200169	240	192	224	0,342
170	49200170	256	220	240	0,269
171	49200171	160	136	150	0,105
172	49200172	183	145	170	0,195
173	49200173	267	220	240	0,362
174	49200174	188	160	177	0,146
175	49200175	211	173	198	0,216
176					
177	49200177	297	249	280	0,391
178	49200178	290	230	260	0,312
179					
180	49200180	226	190	214	0,232
181					
182	49200182	256	225	247	0,228
183					
184	49200184	296	260	287	0,311



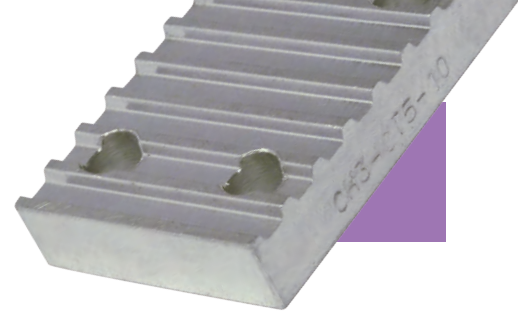

CLAMPING BELTS PLATES

PLATE FOR TIMING BELT POWERGRIP [®] POSITIVE	page 24
PLATE FOR TIMING BELT POWERGRIP [®] HTD [®]	25
PLATE FOR TIMING BELT METRIC PITCH "T"	26
PLATE FOR TIMING BELT METRIC PITCH "AT"	27



CLAMPING PLATES FOR TIMING BELT

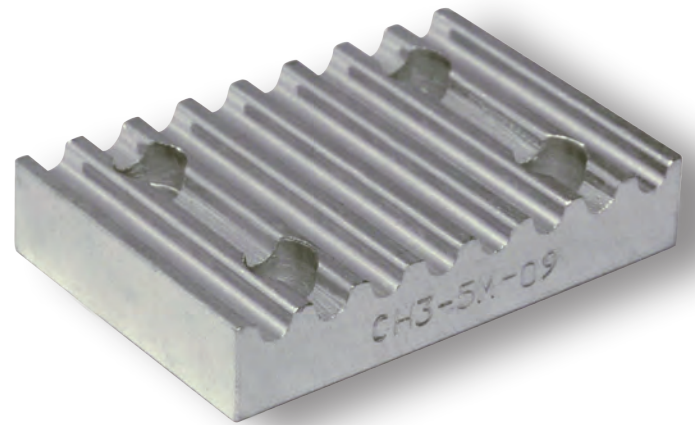
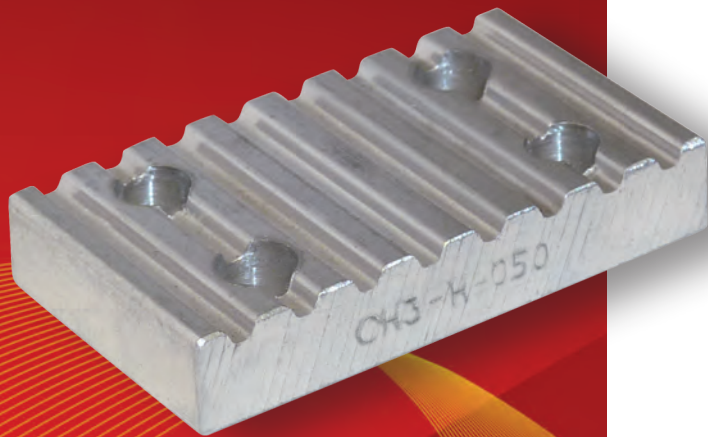

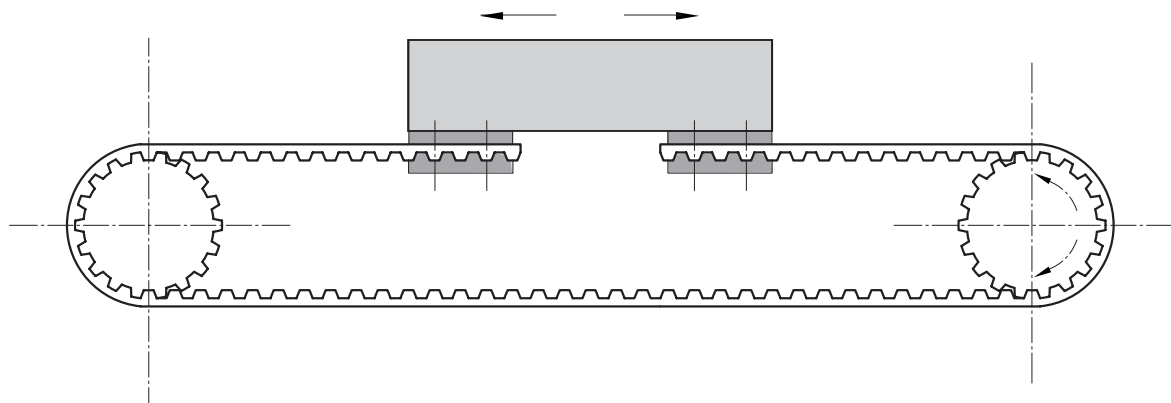
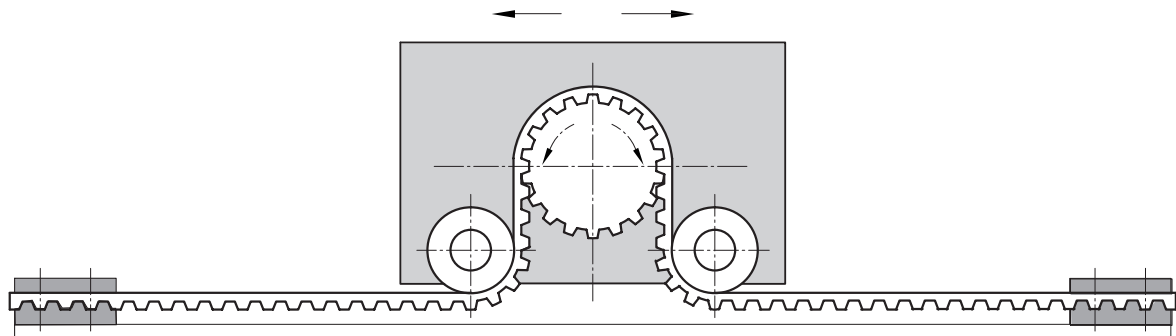

Fixing timing belts through clamping plates enable to modify rotatory motion of pulleys in a linear and alternated motion.

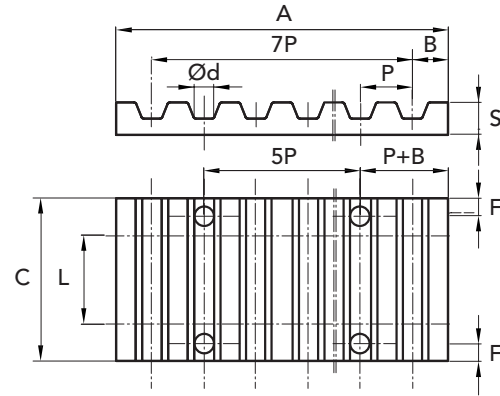
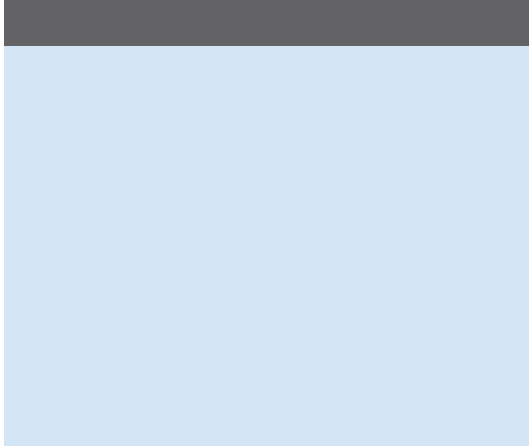

TYPE	PART NUMBER	P	L	F	d	B	A	S	C	WEIGHT Kg.
XL 025	49341001	5,08	6,35	6	5,5	3,5	42,5	8	25,5	0,02
XL 037	49341003	5,08	9,52	6	5,5	3,5	42,5	8	28,5	0,02
L 050	49342050	9,52	12,70	8	9,0	5,0	76,6	15	39	0,10
L 075	49342075	9,52	19,05	8	9,0	5,0	76,6	15	45	0,12
L 100	49342100	9,52	25,40	8	9,0	5,0	76,6	15	51,5	0,16
H 050	49343050	12,70	12,70	10	11,0	9,0	106,9	22	45	0,25
H 075	49343075	12,70	19,05	10	11,0	9,0	106,9	22	51	0,30
H 100	49343100	12,70	25,40	10	11,0	9,0	106,9	22	57,5	0,33

MATERIAL **ALUMINUM**

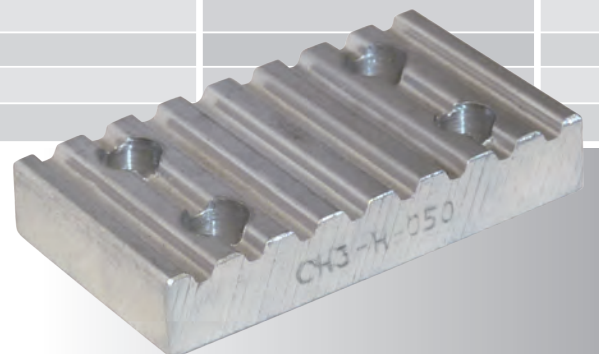

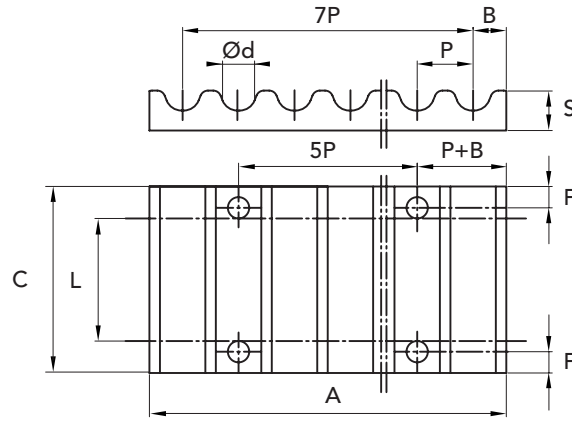

TYPE	PART NUMBER	P	L	F	d	B	A	S	C	WEIGHT Kg.
5M 09	49340209	5	09	6	5,5	3,2	41,5	8	28	0,02
5M 15	49340215	5	15	6	5,5	3,2	41,5	8	34	0,03
5M 25	49340225	5	25	6	5,5	3,2	41,5	8	44	0,04
8M 20	49340420	8	20	8	9	5	66	15	45	0,10
8M 30	49340430	8	30	8	9	5	66	15	55	0,12
8M 50	49340450	8	50	8	9	5	66	15	75	0,17
8M 85	49340485	8	85	8	9	5	66	15	110	0,25
14M 40	49341440	14	40	10	11	9	116	22	71	0,40
14M 55	49341455	14	55	10	11	9	116	22	86	0,50
14M 85	49341485	14	85	10	11	9	116	22	116	0,68
14M 115	49341490	14	115	10	11	9	116	22	146	0,85
14M 170	49341492	14	170	10	11	9	116	22	201	1,20

PLATE FOR TIMING BELT POWERGRIP® HTD®

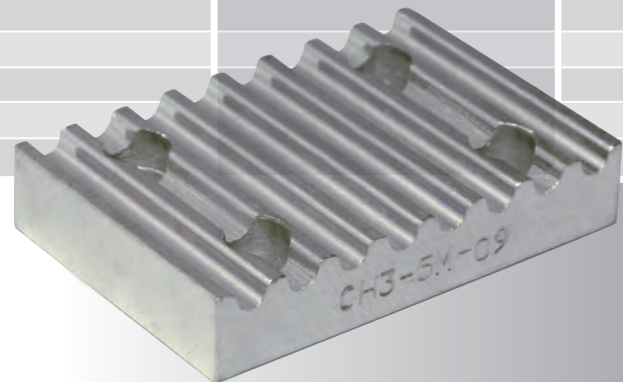

MATERIAL **ALUMINUM**

CAD drawings available on our site
www.chiaravalli.com

Quantity, availability and prices
on B2B Chiaravalli



PLATE FOR TIMING BELT METRIC PITCH "T"

PLATE FOR TIMING BELT METRIC PITCH "T"

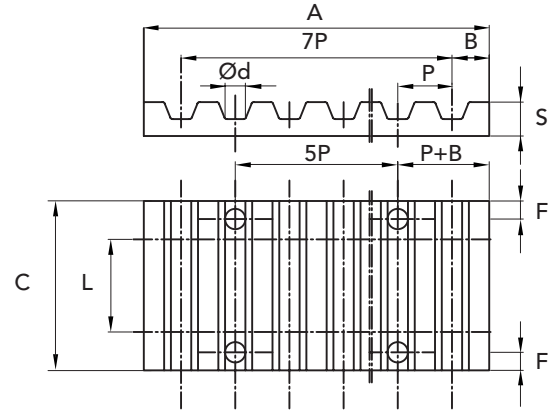
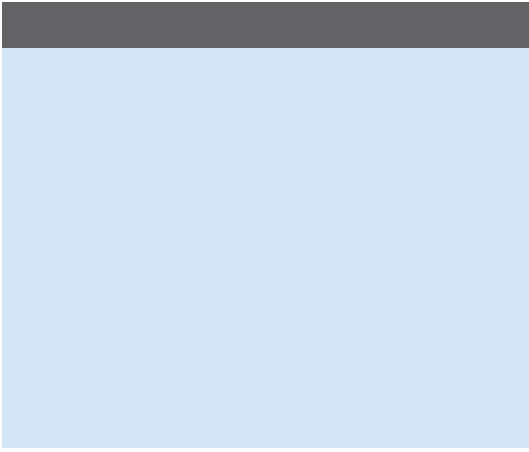

TYPE	PART NUMBER	P	L	F	d	B	A	S	C	WEIGHT Kg.
T5 10	49340510	5	10	6	5,5	3,2	41,8	8	29	0,02
T5 16	49340516	5	16	6	5,5	3,2	41,8	8	35	0,03
T5 25	49340525	5	25	6	5,5	3,2	41,8	8	44	0,04
T10 16	49341016	10	16	8	9	5	80	15	41	0,11
T10 25	49341025	10	25	8	9	5	80	15	50	0,14
T10 32	49341032	10	32	8	9	5	80	15	57	0,16
T10 50	49341050	10	50	8	9	5	80	15	75	0,22

MATERIAL **ALUMINUM**

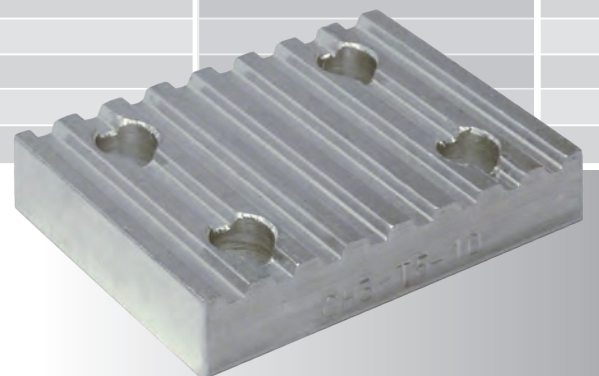

CAD drawings available on our site
www.chiaravalli.com

Quantity, availability and prices
on B2B Chiaravalli

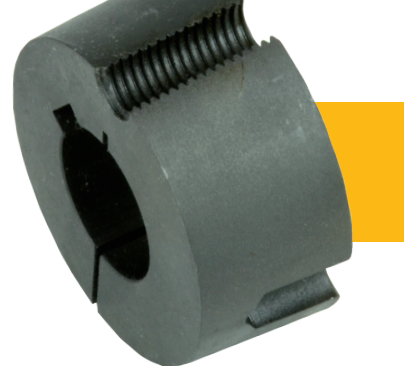

TAPER BUSHES BRAND RCB[®]

SERIES 1008 - 1108 - 1210	page 4
SERIES 1215 - 1610 - 1615	5
SERIES 2012 - 2517	6
SERIES 3020 - 3030	7
SERIES 3525 - 3535	8
SERIES 4030 - 4040 - 4535	9
SERIES 4545 - 5040 - 5050	10
ADAPTORS FOR TAPER BUSHES	11



TAPER BUSHES BRAND RCB®

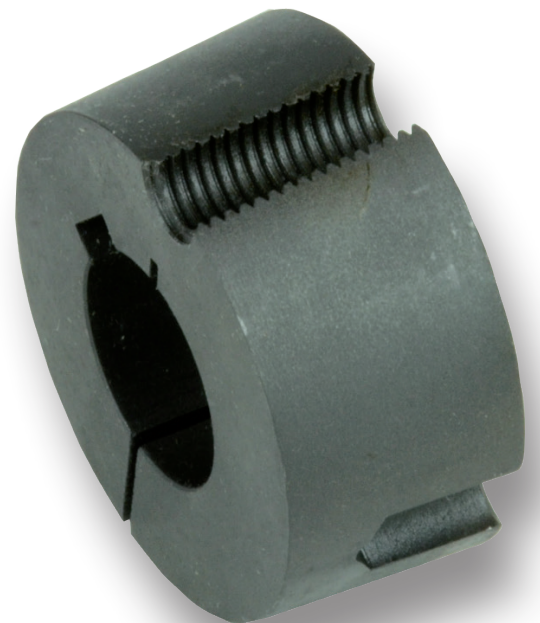



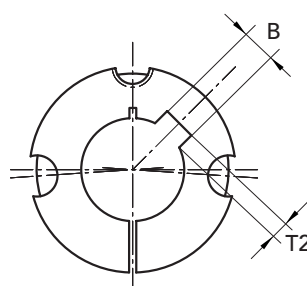

METRIC SERIES

 Reamings in mm. **ISO G7**

 Keyway in compliance with **DIN 6885-JS9**

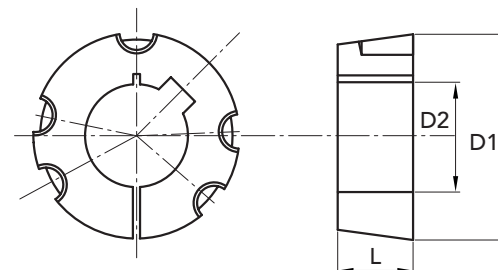
EXECUTION A



EXECUTION B

BUSHES TYPE	Ø D1	PART NUMBER	execution	L	Ø D2 H8 only prebore	Ø D2 with bore ISO G7 keyway DIN 6885-JS9	B keyway width	T2 keyway depth	GRUBSCREW British Standard Whitworth	tightening torque N/m	weight Kg
1008	35	29100800	A	22	8	-	-	-	1/4"x1/2"	5,6	0,13
1008	35	29100808	A	22	-	8	2	1,0	1/4"x1/2"	5,6	0,13
1008	35	29100810	A	22	-	10	3	1,4	1/4"x1/2"	5,6	0,13
1008	35	29100812	A	22	-	12	4	1,8	1/4"x1/2"	5,6	0,12
1008	35	29100814	A	22	-	14	5	2,3	1/4"x1/2"	5,6	0,12
1008	35	29100816	A	22	-	16	5	2,3	1/4"x1/2"	5,6	0,11
1008	35	29100818	A	22	-	18	6	2,8	1/4"x1/2"	5,6	0,10
1008	35	29100819	A	22	-	19	6	2,8	1/4"x1/2"	5,6	0,10
1008	35	29100820	A	22	-	20	6	2,8	1/4"x1/2"	5,6	0,09
1008	35	29100822	A	22	-	22	6	2,8	1/4"x1/2"	5,6	0,08
1008	35	29100824	A	22	-	24	8	2,0	1/4"x1/2"	5,6	0,07
1008	35	29100825	A	22	-	25	8	1,3	1/4"x1/2"	5,6	0,07
1108	38	29110800	A	22	12	-	-	-	1/4"x1/2"	5,6	0,15
1108	38	29110812	A	22	-	12	4	1,8	1/4"x1/2"	5,6	0,15
1108	38	29110814	A	22	-	14	5	2,3	1/4"x1/2"	5,6	0,15
1108	38	29110816	A	22	-	16	5	2,3	1/4"x1/2"	5,6	0,14
1108	38	29110818	A	22	-	18	6	2,8	1/4"x1/2"	5,6	0,13
1108	38	29110819	A	22	-	19	6	2,8	1/4"x1/2"	5,6	0,13
1108	38	29110820	A	22	-	20	6	2,8	1/4"x1/2"	5,6	0,12
1108	38	29110824	A	22	-	24	8	3,3	1/4"x1/2"	5,6	0,10
1108	38	29110825	A	22	-	25	8	3,3	1/4"x1/2"	5,6	0,09
1108	38	29110828	A	22	-	28	8	2,0	1/4"x1/2"	5,6	0,07
1210	47,5	29121000	A	25	12	-	-	-	3/8"x5/8"	19,6	0,28
1210	47,5	29121012	A	25	-	12	4	1,8	3/8"x5/8"	19,6	0,28
1210	47,5	29121014	A	25	-	14	5	2,3	3/8"x5/8"	19,6	0,27
1210	47,5	29121016	A	25	-	16	5	2,3	3/8"x5/8"	19,6	0,26
1210	47,5	29121018	A	25	-	18	6	2,8	3/8"x5/8"	19,6	0,25
1210	47,5	29121019	A	25	-	19	6	2,8	3/8"x5/8"	19,6	0,24
1210	47,5	29121020	A	25	-	20	6	2,8	3/8"x5/8"	19,6	0,24
1210	47,5	29121024	A	25	-	24	8	3,3	3/8"x5/8"	19,6	0,21
1210	47,5	29121025	A	25	-	25	8	3,3	3/8"x5/8"	19,6	0,21
1210	47,5	29121028	A	25	-	28	8	3,3	3/8"x5/8"	19,6	0,18
1210	47,5	29121030	A	25	-	30	8	3,3	3/8"x5/8"	19,6	0,17
1210	47,5	29121032	A	25	-	32	10	3,3	3/8"x5/8"	19,6	0,15

 MATERIAL **GREY CAST IRON**
 norm **UNI EN 1561**

 Bushes with prebore
 without keyway

 CAD drawings available on our site
www.chiaravalli.com

 Quantity, availability and prices
 on B2B Chiaravalli



METRIC SERIES

Reamings in mm. **ISO G7**

Keyway in compliance with **DIN 6885-JS9**

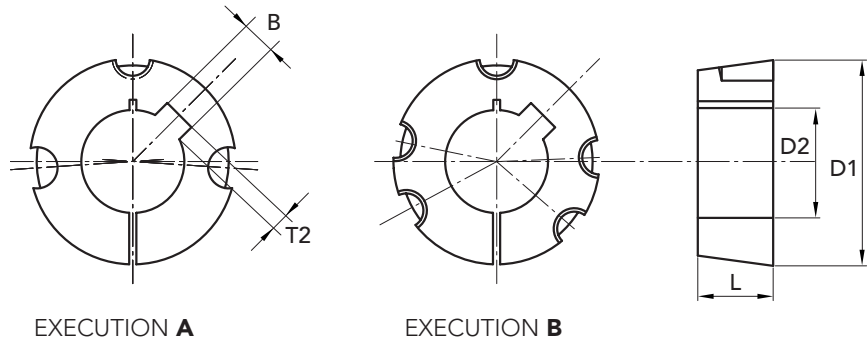

EXECUTION A

EXECUTION B

BUSHES TYPE	Ø D1	PART NUMBER	execution	L	Ø D2 H8 only prebore	Ø D2 with bore ISO G7 keyway DIN 6885-JS9	B keyway width	T2 keyway depth	GRUBSCREW British Standard Whitworth	tightening torque N/m	weight Kg
1215	47,5	29121500	A	38	12	-	-	-	3/8"x5/8"	19,6	0,38
1215	47,5	29121512	A	38	-	12	4	1,8	3/8"x5/8"	19,6	0,38
1215	47,5	29121514	A	38	-	14	5	2,3	3/8"x5/8"	19,6	0,38
1215	47,5	29121519	A	38	-	19	6	2,8	3/8"x5/8"	19,6	0,34
1215	47,5	29121520	A	38	-	20	6	2,8	3/8"x5/8"	19,6	0,34
1215	47,5	29121524	A	38	-	24	8	3,3	3/8"x5/8"	19,6	0,29
1215	47,5	29121525	A	38	-	25	8	3,3	3/8"x5/8"	19,6	0,29
1215	47,5	29121528	A	38	-	28	8	3,3	3/8"x5/8"	19,6	0,26
1610	57	29161000	A	25	12	-	-	-	3/8"x5/8"	19,6	0,41
1610	57	29161012	A	25	-	12	4	1,8	3/8"x5/8"	19,6	0,41
1610	57	29161014	A	25	-	14	5	2,3	3/8"x5/8"	19,6	0,41
1610	57	29161016	A	25	-	16	5	2,3	3/8"x5/8"	19,6	0,40
1610	57	29161018	A	25	-	18	6	2,8	3/8"x5/8"	19,6	0,39
1610	57	29161019	A	25	-	19	6	2,8	3/8"x5/8"	19,6	0,38
1610	57	29161020	A	25	-	20	6	2,8	3/8"x5/8"	19,6	0,38
1610	57	29161022	A	25	-	22	6	2,8	3/8"x5/8"	19,6	0,36
1610	57	29161024	A	25	-	24	8	3,3	3/8"x5/8"	19,6	0,36
1610	57	29161025	A	25	-	25	8	3,3	3/8"x5/8"	19,6	0,35
1610	57	29161028	A	25	-	28	8	3,3	3/8"x5/8"	19,6	0,32
1610	57	29161030	A	25	-	30	8	3,3	3/8"x5/8"	19,6	0,30
1610	57	29161032	A	25	-	32	10	3,3	3/8"x5/8"	19,6	0,29
1610	57	29161035	A	25	-	35	10	3,3	3/8"x5/8"	19,6	0,26
1610	57	29161038	A	25	-	38	10	3,3	3/8"x5/8"	19,6	0,23
1610	57	29161040	A	25	-	40	12	3,3	3/8"x5/8"	19,6	0,21
1610	57	29161042	A	25	-	42	12	2,2	3/8"x5/8"	19,6	0,19
1615	57	29161500	A	38	12	-	-	-	3/8"x5/8"	19,6	0,58
1615	57	29161512	A	38	-	12	4	1,8	3/8"x5/8"	19,6	0,58
1615	57	29161514	A	38	-	14	5	2,3	3/8"x5/8"	19,6	0,58
1615	57	29161516	A	38	-	16	5	2,3	3/8"x5/8"	19,6	0,58
1615	57	29161518	A	38	-	18	6	2,8	3/8"x5/8"	19,6	0,56
1615	57	29161519	A	38	-	19	6	2,8	3/8"x5/8"	19,6	0,55
1615	57	29161520	A	38	-	20	6	2,8	3/8"x5/8"	19,6	0,55
1615	57	29161522	A	38	-	22	6	2,8	3/8"x5/8"	19,6	0,53
1615	57	29161524	A	38	-	24	8	3,3	3/8"x5/8"	19,6	0,50
1615	57	29161525	A	38	-	25	8	3,3	3/8"x5/8"	19,6	0,49
1615	57	29161528	A	38	-	28	8	3,3	3/8"x5/8"	19,6	0,47
1615	57	29161530	A	38	-	30	8	3,3	3/8"x5/8"	19,6	0,45
1615	57	29161532	A	38	-	32	10	3,3	3/8"x5/8"	19,6	0,41
1615	57	29161535	A	38	-	35	10	3,3	3/8"x5/8"	19,6	0,38
1615	57	29161538	A	38	-	38	10	3,3	3/8"x5/8"	19,6	0,32
1615	57	29161540	A	38	-	40	12	3,3	3/8"x5/8"	19,6	0,29
1615	57	29161542	A	38	-	42	12	3,3	3/8"x5/8"	19,6	0,29

METRIC SERIES

 Reamings in mm. **ISO G7**

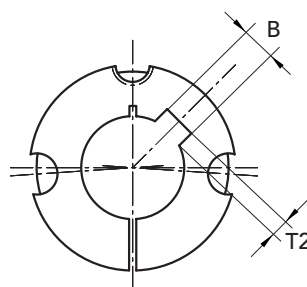
 Keyway in compliance with **DIN 6885-JS9**

EXECUTION A

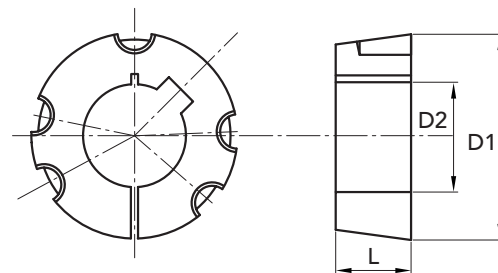

EXECUTION B

BUSHES TYPE	Ø D1	PART NUMBER	execution	L	Ø D2 H8 only prebore	Ø D2 with bore ISO G7 keyway DIN 6885-JS9	B keyway width	T2 keyway depth	GRUBSCREW British Standard Whitworth	tightening torque N/m	weight Kg
2012	70	29201200	A	32	16	-	-	-	7/16"x7/8"	30,4	0,76
2012	70	29201216	A	32	-	16	5	2,3	7/16"x7/8"	30,4	0,76
2012	70	29201218	A	32	-	18	6	2,8	7/16"x7/8"	30,4	0,76
2012	70	29201219	A	32	-	19	6	2,8	7/16"x7/8"	30,4	0,76
2012	70	29201220	A	32	-	20	6	2,8	7/16"x7/8"	30,4	0,75
2012	70	29201224	A	32	-	24	8	3,3	7/16"x7/8"	30,4	0,72
2012	70	29201225	A	32	-	25	8	3,3	7/16"x7/8"	30,4	0,71
2012	70	29201228	A	32	-	28	8	3,3	7/16"x7/8"	30,4	0,68
2012	70	29201230	A	32	-	30	8	3,3	7/16"x7/8"	30,4	0,66
2012	70	29201232	A	32	-	32	10	3,3	7/16"x7/8"	30,4	0,64
2012	70	29201235	A	32	-	35	10	3,3	7/16"x7/8"	30,4	0,60
2012	70	29201238	A	32	-	38	10	3,3	7/16"x7/8"	30,4	0,57
2012	70	29201240	A	32	-	40	12	3,3	7/16"x7/8"	30,4	0,54
2012	70	29201242	A	32	-	42	12	3,3	7/16"x7/8"	30,4	0,51
2012	70	29201245	A	32	-	45	14	3,8	7/16"x7/8"	30,4	0,46
2012	70	29201248	A	32	-	48	14	3,8	7/16"x7/8"	30,4	0,40
2012	70	29201250	A	32	-	50	14	3,8	7/16"x7/8"	30,4	0,37
2517	85,5	29251700	A	45	15	-	-	-	1/2"x1"	48	1,62
2517	85,5	29251715	A	45	-	15	5	2,3	1/2"x1"	48	1,62
2517	85,5	29251718	A	45	-	18	6	2,8	1/2"x1"	48	1,62
2517	85,5	29251719	A	45	-	19	6	2,8	1/2"x1"	48	1,62
2517	85,5	29251720	A	45	-	20	6	2,8	1/2"x1"	48	1,60
2517	85,5	29251722	A	45	-	22	6	2,8	1/2"x1"	48	1,57
2517	85,5	29251724	A	45	-	24	8	3,3	1/2"x1"	48	1,57
2517	85,5	29251725	A	45	-	25	8	3,3	1/2"x1"	48	1,56
2517	85,5	29251728	A	45	-	28	8	3,3	1/2"x1"	48	1,52
2517	85,5	29251730	A	45	-	30	8	3,3	1/2"x1"	48	1,49
2517	85,5	29251732	A	45	-	32	10	3,3	1/2"x1"	48	1,45
2517	85,5	29251733	A	45	-	33	10	3,3	1/2"x1"	48	1,40
2517	85,5	29251735	A	45	-	35	10	3,3	1/2"x1"	48	1,40
2517	85,5	29251738	A	45	-	38	10	3,3	1/2"x1"	48	1,40
2517	85,5	29251740	A	45	-	40	12	3,3	1/2"x1"	48	1,35
2517	85,5	29251742	A	45	-	42	12	3,3	1/2"x1"	48	1,27
2517	85,5	29251745	A	45	-	45	14	3,8	1/2"x1"	48	1,20
2517	85,5	29251748	A	45	-	48	14	3,8	1/2"x1"	48	1,13
2517	85,5	29251750	A	45	-	50	14	3,8	1/2"x1"	48	1,08
2517	85,5	29251755	A	45	-	55	16	4,3	1/2"x1"	48	0,96
2517	85,5	29251760	A	45	-	60	18	4,4	1/2"x1"	48	0,81
2517	85,5	29251765	A	45	-	65	18	3,4	1/2"x1"	48	0,65

 MATERIAL **GREY CAST IRON**
 norm **UNI EN 1561**

 Bushes with prebore
 without keyway

 CAD drawings available on our site
www.chiaravalli.com

 Quantity, availability and prices
 on B2B Chiaravalli



METRIC SERIES

Reamings in mm. **ISO G7**

Keyway in compliance with **DIN 6885-JS9**

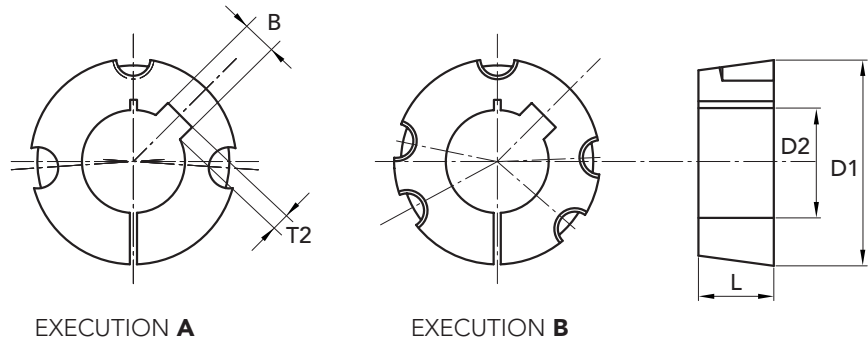

EXECUTION A

EXECUTION B

BUSHES TYPE	Ø D1	PART NUMBER	execution	L	Ø D2 H8 only prebore	Ø D2 with bore ISO G7 keyway DIN 6885-JS9	B keyway width	T2 keyway depth	GRUBSCREW British Standard Whitworth	tightening torque N/m	weight Kg
3020	108	29302000	A	51	20	-	-	-	5/8"x1" 1/4	90	2,79
3020	108	29302020	A	51	-	20	6	2,8	5/8"x1" 1/4	90	2,79
3020	108	29302028	A	51	-	28	8	3,3	5/8"x1" 1/4	90	2,79
3020	108	29302030	A	51	-	30	8	3,3	5/8"x1" 1/4	90	2,84
3020	108	29302032	A	51	-	32	10	3,3	5/8"x1" 1/4	90	2,80
3020	108	29302035	A	51	-	35	10	3,3	5/8"x1" 1/4	90	2,75
3020	108	29302038	A	51	-	38	10	3,3	5/8"x1" 1/4	90	2,67
3020	108	29302040	A	51	-	40	12	3,3	5/8"x1" 1/4	90	2,64
3020	108	29302042	A	51	-	42	12	3,3	5/8"x1" 1/4	90	2,59
3020	108	29302045	A	51	-	45	14	3,8	5/8"x1" 1/4	90	2,52
3020	108	29302048	A	51	-	48	14	3,8	5/8"x1" 1/4	90	2,43
3020	108	29302050	A	51	-	50	14	3,8	5/8"x1" 1/4	90	2,37
3020	108	29302055	A	51	-	55	16	4,3	5/8"x1" 1/4	90	2,23
3020	108	29302060	A	51	-	60	18	4,4	5/8"x1" 1/4	90	2,07
3020	108	29302065	A	51	-	65	18	4,4	5/8"x1" 1/4	90	1,89
3020	108	29302070	A	51	-	70	20	4,9	5/8"x1" 1/4	90	1,69
3020	108	29302075	A	51	-	75	20	4,9	5/8"x1" 1/4	90	1,49
3030	108	29303000	A	76	30	-	-	-	5/8"x1" 1/4	90	3,95
3030	108	29303030	A	76	-	30	8	3,3	5/8"x1" 1/4	90	3,95
3030	108	29303035	A	76	-	35	10	3,3	5/8"x1" 1/4	90	3,95
3030	108	29303038	A	76	-	38	10	3,3	5/8"x1" 1/4	90	3,86
3030	108	29303042	A	76	-	42	12	3,3	5/8"x1" 1/4	90	3,69
3030	108	29303045	A	76	-	45	14	3,8	5/8"x1" 1/4	90	3,55
3030	108	29303048	A	76	-	48	14	3,8	5/8"x1" 1/4	90	3,45
3030	108	29303050	A	76	-	50	14	3,8	5/8"x1" 1/4	90	3,42
3030	108	29303055	A	76	-	55	16	4,3	5/8"x1" 1/4	90	3,18
3030	108	29303060	A	76	-	60	18	4,4	5/8"x1" 1/4	90	2,95
3030	108	29303065	A	76	-	65	18	4,4	5/8"x1" 1/4	90	2,68
3030	108	29303070	A	76	-	70	20	4,9	5/8"x1" 1/4	90	2,38
3030	108	29303075	A	76	-	75	20	4,9	5/8"x1" 1/4	90	2,03

MATERIAL **GREY CAST IRON**
norm UNI EN 1561

Bushes with prebore
without keyway

CAD drawings available on our site
www.chiaravalli.com

Quantity, availability and prices
on B2B Chiaravalli

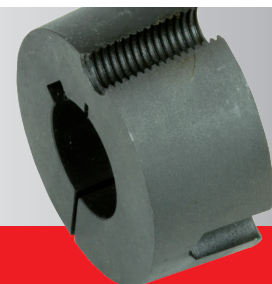

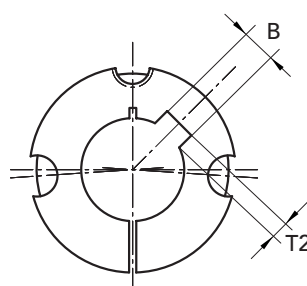

METRIC SERIES

 Reamings in mm. **ISO G7**

 Keyway in compliance with **DIN 6885-JS9**

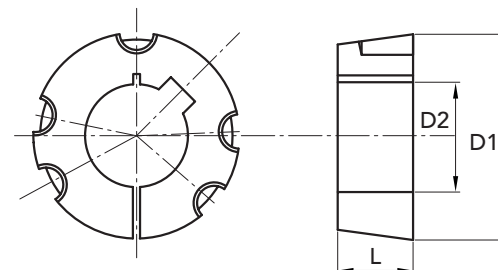
EXECUTION A



EXECUTION B

BUSHES TYPE	Ø D1	PART NUMBER	execution	L	Ø D2 H8 only prebore	Ø D2 with bore ISO G7 keyway DIN 6885-JS9	B keyway width	T2 keyway depth	GRUBSCREW British Standard Whitworth	tightening torque N/m	weight Kg
3525	127	29352500	B	65	30	-	-	-	1/2"x1" 1/2	113	4,85
3525	127	29352530	B	65	-	30	8	3,3	1/2"x1" 1/2	113	4,85
3525	127	29352538	B	65	-	38	10	3,3	1/2"x1" 1/2	113	4,85
3525	127	29352540	B	65	-	40	12	3,3	1/2"x1" 1/2	113	4,80
3525	127	29352542	B	65	-	42	12	3,3	1/2"x1" 1/2	113	4,71
3525	127	29352545	B	65	-	45	14	3,8	1/2"x1" 1/2	113	4,67
3525	127	29352548	B	65	-	48	14	3,8	1/2"x1" 1/2	113	4,55
3525	127	29352550	B	65	-	50	14	3,8	1/2"x1" 1/2	113	4,44
3525	127	29352555	B	65	-	55	16	4,3	1/2"x1" 1/2	113	4,29
3525	127	29352560	B	65	-	60	18	4,4	1/2"x1" 1/2	113	4,05
3525	127	29352565	B	65	-	65	18	4,4	1/2"x1" 1/2	113	3,88
3525	127	29352570	B	65	-	70	20	4,9	1/2"x1" 1/2	113	3,58
3525	127	29352575	B	65	-	75	20	4,9	1/2"x1" 1/2	113	3,37
3525	127	29352580	B	65	-	80	22	5,4	1/2"x1" 1/2	113	3,05
3525	127	29352585	B	65	-	85	22	5,4	1/2"x1" 1/2	113	3,05
3525	127	29352590	B	65	-	90	25	5,4	1/2"x1" 1/2	113	3,05
3535	127	29353500	B	89	30	-	-	-	1/2"x1" 1/2	113	6,48
3535	127	29353530	B	89	-	30	8	3,3	1/2"x1" 1/2	113	6,48
3535	127	29353535	B	89	-	35	10	3,3	1/2"x1" 1/2	113	6,40
3535	127	29353540	B	89	-	40	12	3,3	1/2"x1" 1/2	113	6,48
3535	127	29353542	B	89	-	42	12	3,3	1/2"x1" 1/2	113	6,40
3535	127	29353545	B	89	-	45	14	3,8	1/2"x1" 1/2	113	6,25
3535	127	29353548	B	89	-	48	14	3,8	1/2"x1" 1/2	113	6,17
3535	127	29353550	B	89	-	50	14	3,8	1/2"x1" 1/2	113	6,05
3535	127	29353555	B	89	-	55	16	4,3	1/2"x1" 1/2	113	5,81
3535	127	29353560	B	89	-	60	18	4,4	1/2"x1" 1/2	113	5,50
3535	127	29353565	B	89	-	65	18	4,4	1/2"x1" 1/2	113	5,20
3535	127	29353570	B	89	-	70	20	4,9	1/2"x1" 1/2	113	4,88
3535	127	29353575	B	89	-	75	20	4,9	1/2"x1" 1/2	113	4,46
3535	127	29353580	B	89	-	80	22	5,4	1/2"x1" 1/2	113	4,08
3535	127	29353585	B	89	-	85	22	5,4	1/2"x1" 1/2	113	3,67
3535	127	29353590	B	89	-	90	25	5,4	1/2"x1" 1/2	113	3,21

 MATERIAL **GREY CAST IRON**
 norm **UNI EN 1561**

 Bushes with prebore
 without keyway

 CAD drawings available on our site
www.chiaravalli.com

 Quantity, availability and prices
 on B2B Chiaravalli





METRIC SERIES

Reamings in mm. **ISO G7**

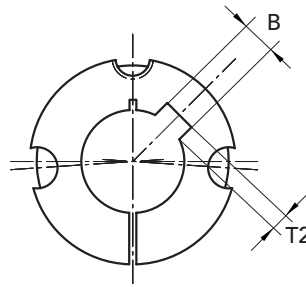
Keyway in compliance with **DIN 6885-JS9**

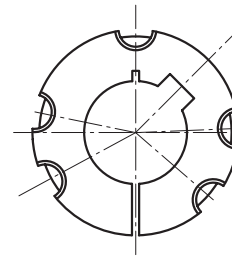

EXECUTION A



EXECUTION B

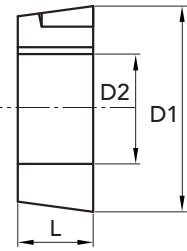

BUSHES TYPE	Ø D1	PART NUMBER	execution	L	Ø D2 H8 only prebore	Ø D2 with bore ISO G7 keyway DIN 6885-JS9	B keyway width	T2 keyway depth	GRUBSCREW British Standard Whitworth	tightening torque N/m	weight Kg
4030	146	29403000	B	76	30	-	-	-	5/8"x1" 3/4	169	6,65
4030	146	29403030	B	76	-	30	8	3,3	5/8"x1" 3/4	169	6,65
4030	146	29403040	B	76	-	40	12	3,3	5/8"x1" 3/4	169	6,75
4030	146	29403042	B	76	-	42	12	3,3	5/8"x1" 3/4	169	6,65
4030	146	29403045	B	76	-	45	14	3,8	5/8"x1" 3/4	169	6,58
4030	146	29403048	B	76	-	48	14	3,8	5/8"x1" 3/4	169	6,55
4030	146	29403050	B	76	-	50	14	3,8	5/8"x1" 3/4	169	6,40
4030	146	29403055	B	76	-	55	16	4,3	5/8"x1" 3/4	169	6,40
4030	146	29403060	B	76	-	60	18	4,4	5/8"x1" 3/4	169	6,35
4030	146	29403065	B	76	-	65	18	4,4	5/8"x1" 3/4	169	6,35
4030	146	29403070	B	76	-	70	20	4,9	5/8"x1" 3/4	169	6,30
4030	146	29403075	B	76	-	75	20	4,9	5/8"x1" 3/4	169	6,30
4030	146	29403080	B	76	-	80	22	5,4	5/8"x1" 3/4	169	6,10
4030	146	29403085	B	76	-	85	22	5,4	5/8"x1" 3/4	169	6,10
4030	146	29403090	B	76	-	90	25	5,4	5/8"x1" 3/4	169	5,90
4040	146	29404000	B	102	35	-	-	-	5/8"x 1" 3/4	169	9,48
4040	146	29404035	B	102	-	35	10	3,3	5/8"x 1" 3/4	169	9,48
4040	146	29404050	B	102	-	50	14	3,8	5/8"x 1" 3/4	169	9,48
4040	146	29404055	B	102	-	55	16	4,3	5/8"x 1" 3/4	169	9,27
4040	146	29404060	B	102	-	60	18	4,4	5/8"x 1" 3/4	169	8,93
4040	146	29404065	B	102	-	65	18	4,4	5/8"x 1" 3/4	169	8,65
4040	146	29404070	B	102	-	70	20	4,9	5/8"x 1" 3/4	169	8,17
4040	146	29404075	B	102	-	75	20	4,9	5/8"x 1" 3/4	169	7,78
4040	146	29404080	B	102	-	80	22	5,4	5/8"x 1" 3/4	169	7,35
4040	146	29404085	B	102	-	85	22	5,4	5/8"x 1" 3/4	169	6,89
4040	146	29404090	B	102	-	90	25	5,4	5/8"x 1" 3/4	169	6,36
4040	146	29404095	B	102	-	95	25	5,4	5/8"x 1" 3/4	169	5,94
4535	162	29453500	B	89	35	-	-	-	3/4"x2"	192	10,70
4535	162	29453535	B	89	-	35	10	3,3	3/4"x2"	192	10,70
4535	162	29453565	B	89	-	65	18	4,4	3/4"x2"	192	10,50
4535	162	29453570	B	89	-	70	20	4,9	3/4"x2"	192	10,20
4535	162	29453575	B	89	-	75	20	4,9	3/4"x2"	192	9,95
4535	162	29453580	B	89	-	80	22	5,4	3/4"x2"	192	9,95
4535	162	29453585	B	89	-	85	22	5,4	3/4"x2"	192	9,90
4535	162	29453590	B	89	-	90	25	5,4	3/4"x2"	192	9,80
4535	162	29453595	B	89	-	95	25	5,4	3/4"x2"	192	9,75
4535	162	29453599	B	89	-	100	28	6,4	3/4"x2"	192	9,65
4535	162	29453110	B	89	-	110	28	6,4	3/4"x2"	192	9,55
4535	162	29453120	B	89	-	120	32	7,4	3/4"x2"	192	9,45

MATERIAL **GREY CAST IRON**
norm UNI EN 1561

Bushes with prebore
without keway

CAD drawings available on our site
www.chiaravalli.com

Quantity, availability and prices
on B2B Chiaravalli

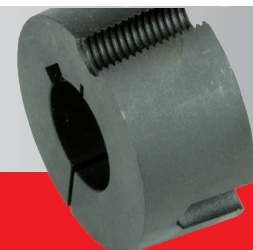

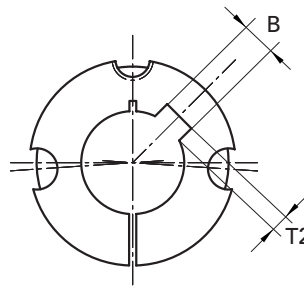

METRIC SERIES

 Reamings in mm. **ISO G7**

 Keyway in compliance with **DIN 6885-JS9**

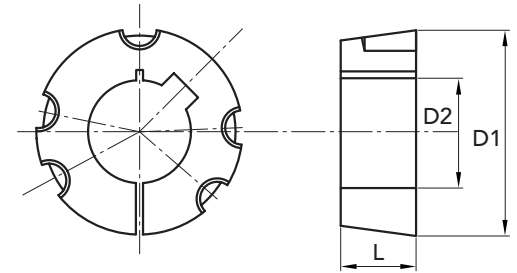
EXECUTION A



EXECUTION B

BUSHES TYPE	Ø D1	PART NUMBER	execution	L	Ø D2 H8 only prebore	Ø D2 with bore ISO G7 keyway DIN 6885-JS9	B keyway width	T2 keyway depth	GRUBSCREW British Standard Whitworth	tightening torque N/m	weight Kg
4545	162	29454500	B	115	35	-	-	-	3/4"x2"	192	13,15
4545	162	29454535	B	115	-	35	10	3,3	3/4"x2"	192	13,15
4545	162	29454555	B	115	-	55	16	4,3	3/4"x2"	192	13,15
4545	162	29454560	B	115	-	60	18	4,4	3/4"x2"	192	12,76
4545	162	29454565	B	115	-	65	18	4,4	3/4"x2"	192	12,38
4545	162	29454570	B	115	-	70	20	4,9	3/4"x2"	192	12,02
4545	162	29454575	B	115	-	75	20	4,9	3/4"x2"	192	11,57
4545	162	29454580	B	115	-	80	22	5,4	3/4"x2"	192	11,05
4545	162	29454585	B	115	-	85	22	5,4	3/4"x2"	192	10,46
4545	162	29454590	B	115	-	90	25	5,4	3/4"x2"	192	9,99
4545	162	29454595	B	115	-	95	25	5,4	3/4"x2"	192	9,42
4545	162	29454599	B	115	-	100	28	6,4	3/4"x2"	192	8,63
4545	162	29454610	B	115	-	110	28	6,4	3/4"x2"	192	7,37
5040	177,6	29504040	B	102	40	-	-	-	7/8"x2" 1/4	272	12,20
5040	177,6	29504050	B	102	-	50	14	3,8	7/8"x2" 1/4	272	12,20
5040	177,6	29504070	B	102	-	70	20	4,9	7/8"x2" 1/4	272	11,90
5040	177,6	29504075	B	102	-	75	20	4,9	7/8"x2" 1/4	272	11,90
5040	177,6	29504080	B	102	-	80	22	5,4	7/8"x2" 1/4	272	11,30
5040	177,6	29504085	B	102	-	85	22	5,4	7/8"x2" 1/4	272	11,30
5040	177,6	29504090	B	102	-	90	25	5,4	7/8"x2" 1/4	272	10,60
5040	177,6	29504099	B	102	-	100	28	6,4	7/8"x2" 1/4	272	10,60
5040	177,6	29504110	B	102	-	110	28	6,4	7/8"x2" 1/4	272	10,00
5040	177,6	29504120	B	102	-	120	32	7,4	7/8"x2" 1/4	272	9,70
5040	177,6	29504125	B	102	-	125	32	7,4	7/8"x2" 1/4	272	9,70
5050	177,6	29505000	B	127	50	-	-	-	7/8"x2" 1/4	272	16,70
5050	177,6	29505050	B	127	-	50	14	3,8	7/8"x2" 1/4	272	16,70
5050	177,6	29505065	B	127	-	65	18	4,4	7/8"x2" 1/4	272	16,70
5050	177,6	29505070	B	127	-	70	20	4,9	7/8"x2" 1/4	272	16,70
5050	177,6	29505075	B	127	-	75	20	4,9	7/8"x2" 1/4	272	16,05
5050	177,6	29505080	B	127	-	80	22	5,4	7/8"x2" 1/4	272	15,56
5050	177,6	29505085	B	127	-	85	22	5,4	7/8"x2" 1/4	272	15,00
5050	177,6	29505090	B	127	-	90	25	5,4	7/8"x2" 1/4	272	14,43
5050	177,6	29505095	B	127	-	95	25	5,4	7/8"x2" 1/4	272	13,88
5050	177,6	29505099	B	127	-	100	28	6,4	7/8"x2" 1/4	272	13,05
5050	177,6	29505110	B	127	-	110	28	6,4	7/8"x2" 1/4	272	11,56
5050	177,6	29505115	B	127	-	115	32	7,4	7/8"x2" 1/4	272	15,17
5050	177,6	29505120	B	127	-	120	32	7,4	7/8"x2" 1/4	272	9,78
5050	177,6	29505125	B	127	-	125	32	7,4	7/8"x2" 1/4	272	9,05

MATERIAL GREY CAST IRON
 norm UNI EN 1561

 Bushes with prebore
 without keyway

 CAD drawings available on our site
www.chiaravalli.com

 Quantity, availability and prices
 on B2B Chiaravalli

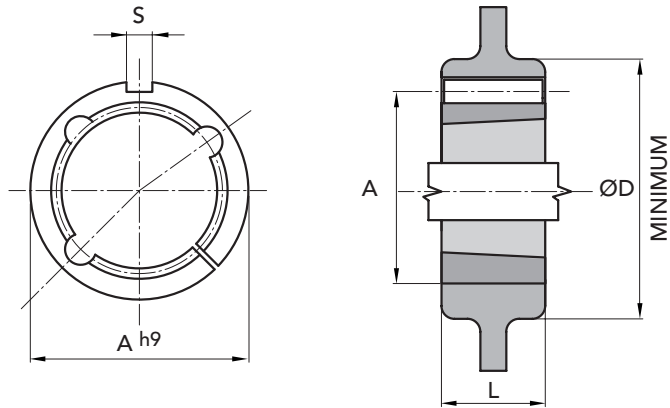
TYPE ADAPTORS	PART NUMBER	N. TAPER BUSHE	L	A h9	Ø D FOR HUBS of PULLEYS and SPROCKETS in CAST IRON and STEEL		S DIN 6885	WEIGHT Kg. for C.I.
ARC 1008	29901008	1008	22	45	75	60	5 x 5	0,45
ARC 1210	29901210	1210	25	60	105	85	6 x 6	0,70
ARC 1610	29901610	1610	25	70	115	95	10 x 8	0,80
ARC 1615	29901615	1615	38	70	115	95	10 x 8	0,90
ARC 2517	29902517	2517	45	105	150	130	16 x 10	2,20
ARC 3030	29903030	3030	76	130	190	160	20 x 12	5,80
ARC 3535	29903535	3535	90	160	240	* 200	22 x 12	11,30
ARC 4040	29904040	4040	102	185	290	* 240	24 x 12	17,30

MATERIAL **GREY CAST IRON**
norm UNI EN 1561

* They differ from the Norma DIN 6885

CAD drawings available on our site
www.chiaravalli.com

Quantity, availability and prices
on B2B Chiaravalli





RCK[®]

CLAMPING ELEMENTS

SERIES RCK 11	page 6
SERIES RCK 13	7
SERIES RCK 15	8
SERIES RCK 16	9
SERIES RCK 19	10
SERIES RCK 40	11
SERIES RCK 45	12
SERIES RCK 50	13
SERIES RCK 55	14
SERIES RCK 60	15
SERIES RCK 61	16
SERIES RCK 70	17
SERIES RCK 71	18
SERIES RCK 80	19
SERIES RCK 95	20



MINIMUM HUB DIAMETER CHECK D_m

After choosing the clamping element type with the required characteristics it is necessary to make a check on the minimum extern diameter of the hub (D_m), which has to resist to the solicitations caused by the high pressures developed by the clamping element. The check is purely static and concerns just solicitations caused by the clamping element:

$$D_m \geq D \times \sqrt{\frac{R_{s 0.2} + (P_m \times C)}{R_{s 0.2} - (P_m \times C)}}$$

Where: D_m = Extern diameter of the hub (mm)

D = Extern diameter of the clamping element (mm)

$R_{s 0.2}$ = Yield point for permanent elongation of 0.2% (N/mm²)

P_m = Specific pressure exercised by the clamping element on the hub (N/mm²)

C = coefficient of the utilization in function of the hub profile (Look at the pictures below)

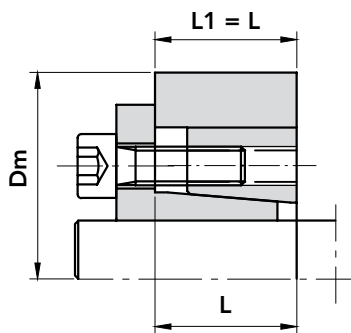

C = 1

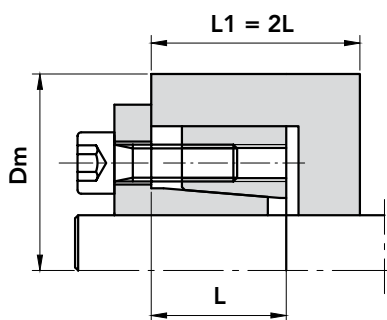
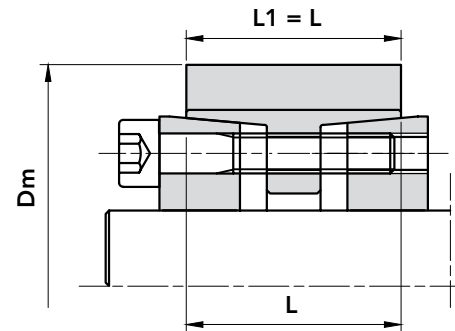

C = 0.8

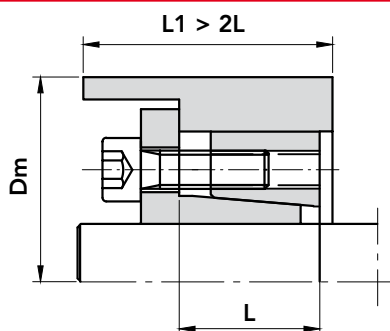
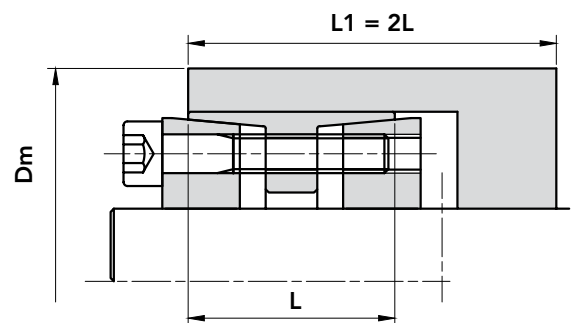

C = 0.6

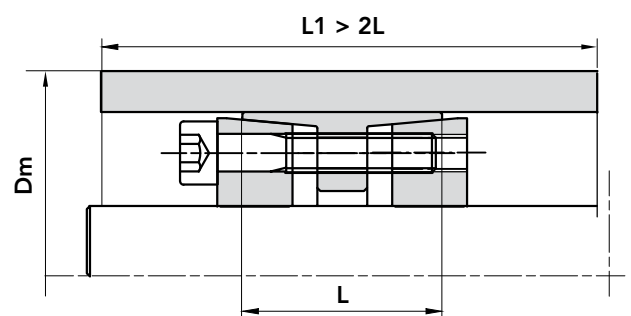



The clamping system connects one or two components parts solidly to the drive shaft, which allows motion to be transmitted or to withstand an axial thrust. Friction connection enables gaps to be eliminated, thereby ensuring greater precision of the keyed components without requiring strict processing tolerances. The thrust cones develop a pressure between the shaft and the hub, which enables pulleys, gears, chain sprockets, drums, flywheels, etc. to be anchored safely. The easy assembly and disassembly features give users many advantages, leading to a further cost saving.

Chiaravalli Group S.p.A. provides its customers with different types of clamping elements, which are designed to cover a broad range of applications.



SHAFT CLAMPING ELEMENTS

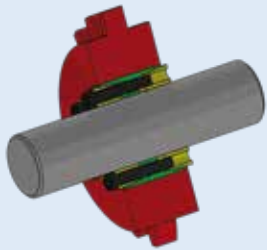

RCK 11

SELF CENTRING RCK 11 TYPE

Suitable for assemblies where special, even heavy-duty conditions are required, achieving maximum friction clamping results. It incorporates the best features of all the models which have been presented. It operates with very high torque values.

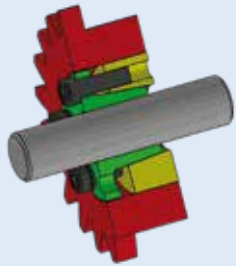

RCK 13

SELF CENTRING RCK 13 TYPE

Suitable for assemblies where good concentricity is required in small spaces with medium- high torque values. It can substitute RCK 40 in some cases.

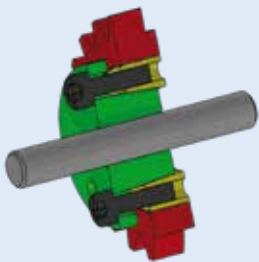

RCK 15

SELF CENTRING RCK 15 TYPE

Suitable for assemblies where axial and radial positioning accuracy is required with medium- high torque values. The main feature is the possibility of varying the internal bores while maintaining the external dimensions constant at only three diameters.

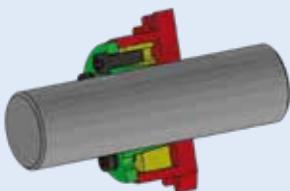

RCK 16

SELF CENTRING RCK 16 TYPE

Suitable for assemblies where concentricity and positioning accuracy is required. It operates with medium- high torque values.

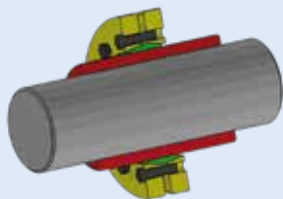
**RCK 19****SELF CENTRING RCK 19 TYPE**

Suitable for hollow shafts, it operates by compressing the hollow shafts on the solid shafts enabling transmission of medium high twisting moments to be achieved.

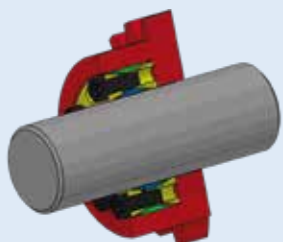
**RCK 40****NOT SELF CENTRING RCK 40 TYPE**

Suitable for general applications, it is not self centring and therefore requires a centring band to ensure perfect concentricity. It operates with medium- high torque values.

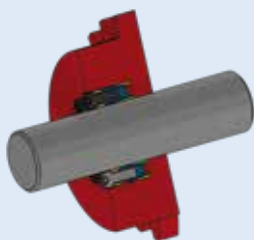
**RCK 45****NOT SELF CENTRING RCK 45 TYPE**

Suitable for applications where medium-low twisting moments are required with, easy rapid assembly and disassembly operation. Not self centring.

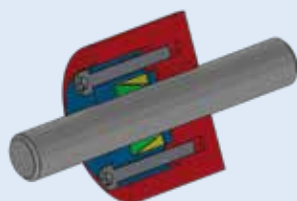
**RCK 50****NOT SELF CENTRING RCK 50 TYPE**

Comprising two tapered rings, must always be mounted with a tightening flange. It operates with low torque values; it isn't self centring.

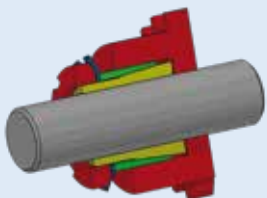
**RCK 55****SELF CENTRING RCK 55 TYPE**

Suitable for assemblies where limited overall dimensions and times are required. It operates with medium-low torque values.

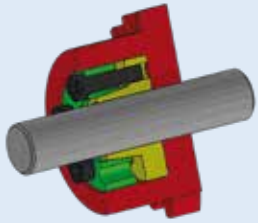

RCK 60

SELF CENTRING RCK 60 TYPE

Suitable for assemblies where a medium-high twisting moment is required. It operates in the opposite mode to RCK 13.

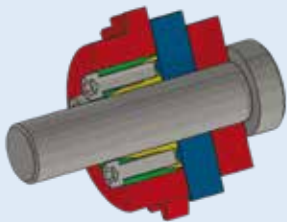

RCK 61

SELF CENTRING RCK 61 TYPE

Enables adjacent components to be clamped to the hub thanks to an axial force achieved during the clamping phase. It operates with medium torque values.

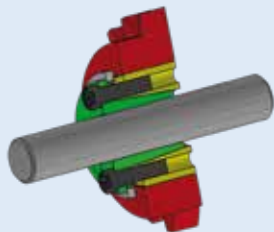

RCK 70-71

SELF CENTRING RCK 70-71 TYPE (RCK 71 eventually with spacer)

The RCK version is suitable for assemblies where concentricity and orthogonal positioning of the parts is required. The RCK 71 version has the same features as RCK 70 with the addition of a spacer ring to completely avoid possible axial displacements. These components operates with medium- high torque values.

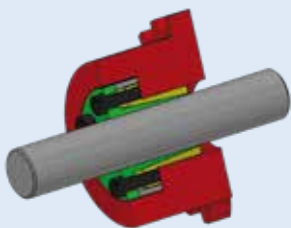

RCK 80

SELF CENTRING RCK 80 TYPE

Suitable for assemblies on hubs with thin walls guarantees both axial and radial positioning precision with medium transmission torque values.

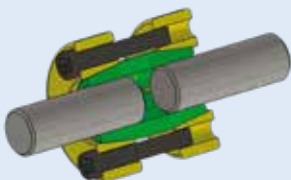

RCK 95

Enables rigid connection between two aligned shafts. It transmits medium-high twisting moments with the advantage of enabling rapid assembly and disassembly



SELF CENTRING

THE RECOMMENDED MACHINING TOLERANCES FOR THE PRESSURE SURFACES ARE AS FOLLOWS:

$\varnothing h 8$ FOR SHAFT

$\varnothing H 8$ FOR HUB

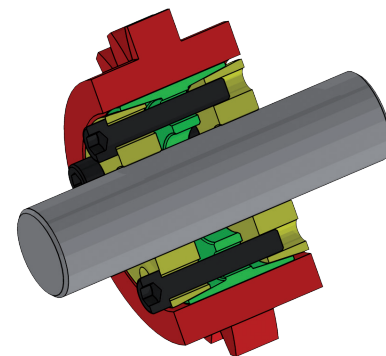
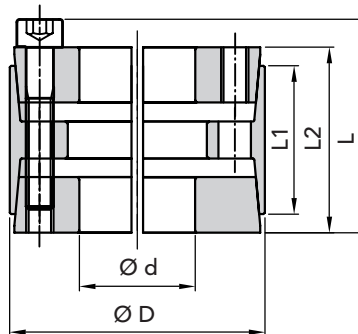

PART NUMBER	DIMENSIONS					maximum torque Mt Nm	CLAMPING PRESSURE			CLAMPING SCREWS DIN 912 MAT. 12.9		EXTRACTION THREAD		WEIGHT Kg
	Ød	ØD	L1	L2	L		Shaft N/mm ²	Hub N/mm ²	N°	Type	Torque Nm	Type	N°	
06110025	25	55	32	40	46	840	295	134	6	M6x35	17	M6	3	0,50
06110028	28	55	32	40	46	940	264	134	6	M6x35	17	M6	3	0,60
06110030	30	55	32	40	46	1000	246	134	6	M6x35	17	M6	3	0,60
06110035	35	60	44	54	60	1360	174	101	7	M6x45	17	M6	3	0,70
06110038	38	75	44	54	62	2740	296	150	7	M8x50	41	M8	3	0,70
06110040	40	75	44	54	62	2880	281	150	7	M8x50	41	M8	3	0,70
06110042	42	75	44	54	62	3030	268	150	7	M8x50	41	M8	3	1,00
06110045	45	75	44	54	62	3240	250	150	7	M8x50	41	M8	3	0,90
06110048	48	80	56	64	72	3950	207	124	8	M8x50	41	M8	3	1,40
06110050	50	80	56	64	72	4150	200	98	8	M8x50	41	M8	3	1,30
06110055	55	85	56	64	72	5150	205	104	9	M8x50	41	M8	3	1,50
06110060	60	90	56	64	72	6200	202	106	10	M8x50	41	M8	4	1,60
06110065	65	95	56	64	72	6750	187	100	10	M8x50	41	M8	4	1,80
06110070	70	110	70	78	88	11500	223	114	10	M10x60	83	M10	4	3,00
06110075	75	115	70	78	88	12300	223	114	10	M10x60	83	M10	4	3,30
06110080	80	120	70	78	88	14500	215	115	11	M10x60	83	M10	4	3,50
06110085	85	125	70	78	88	15400	215	115	12	M10x60	83	M10	5	3,70
06110090	90	130	70	78	88	17800	208	115	12	M10x60	83	M10	5	3,55
06110095	95	135	70	78	88	18700	208	115	12	M10x60	83	M10	5	3,75
06110100	100	145	90	100	112	26300	200	107	11	M12x80	145	M12	4	5,80
06110110	110	155	90	100	112	31800	198	110	12	M12x80	145	M12	5	6,25
06110120	120	165	90	100	112	40400	212	120	14	M12x80	145	M12	5	6,65
06110130	130	180	104	116	130	51500	192	112	12	M14x90	230	M14	5	9,30
06110140	140	190	104	116	130	64700	208	124	14	M14x90	230	M14	7	9,75
06110150	150	200	104	116	130	74200	208	127	15	M14x90	230	M14	6	10,35
06110160	160	210	104	116	130	84500	208	128	16	M14x90	230	M14	7	10,95
06110170	170	225	134	148	164	108200	182	113	14	M16x110	355	M16	6	16,20
06110180	180	235	134	148	164	123250	184	115	15	M16x110	355	M16	7	16,90
06110190	190	250	134	148	164	133800	186	116	16	M16x110	355	M16	7	19,85
06110200	200	260	134	148	164	146000	177	112	16	M16x110	355	M16	7	22,00
06110220	220	285	134	148	164	181000	188	115	18	M16x110	355	M16	8	25,00
06110240	240	305	134	148	164	218000	184	119	20	M16x110	355	M16	9	27,00
06110260	260	325	134	148	164	250000	178	117	21	M16x110	355	M16	10	30,00
06110280	280	355	165	177	197	360000	185	117	18	M20x130	690	M20	8	46,00
06110300	300	375	165	177	197	428000	192	123	20	M20x130	690	M20	9	50,00

ORDERING EXAMPLE:

The following will be ordered with a shaft having $\varnothing d$ 45 with torque value less or equal to 3.200 Nm:

RCK 11 - 45 x 75

Part Number 06110045

CAD drawings available on our site
www.chiaravalli.com

3D simulation available on the website.

Quantity, availability and prices
on B2B Chiaravalli

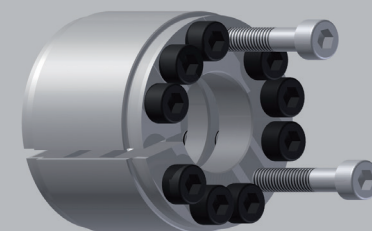



RCK 13 TYPE CLAMPING ELEMENTS

SELF CENTRING

THE RECOMMENDED MACHINING TOLERANCES FOR THE PRESSURE SURFACES ARE AS FOLLOWS:

Ø h 8 FOR SHAFT

Ø H 8 FOR HUB

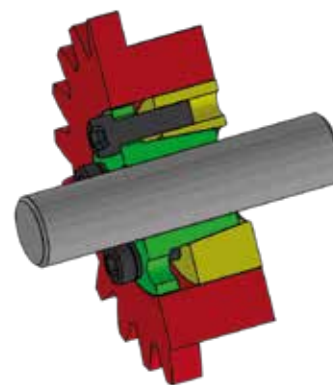
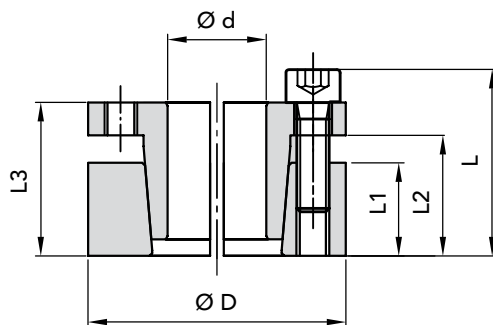

DIMENSIONS

PART NUMBER	Ød	ØD	DIMENSIONS				maximum torque Mt Nm	CLAMPING PRESSURE		CLAMPING SCREWS DIN 912 MAT. 12.9			EXTRACTION THREAD		WEIGHT Kg
			L1	L2	L3	L		Shaft N/mm ²	Hub N/mm ²	N.	Type	Torque Nm	Type	N.	
06130018	18	47	17	22	28	34	310	314	120	5	M6x20	14	M6	3	0,15
06130019	19	47	17	22	28	34	330	300	120	5	M6x20	14	M6	3	0,15
06130020	20	47	17	22	28	34	380	295	125	5	M6x20	14	M6	3	0,15
06130022	22	47	17	22	28	34	410	270	125	5	M6x20	14	M6	3	0,30
06130024	24	50	17	22	28	34	440	243	120	6	M6x20	14	M6	3	0,30
06130025	25	50	17	22	28	34	560	285	140	6	M6x20	14	M6	3	0,30
06130028	28	55	17	22	28	34	630	255	130	6	M6x20	14	M6	3	0,35
06130030	30	55	17	22	28	34	660	235	130	6	M6x20	14	M6	3	0,35
06130032	32	60	17	22	28	34	960	295	155	8	M6x20	14	M6	4	0,40
06130035	35	60	17	22	28	34	1050	270	155	8	M6x20	14	M6	4	0,40
06130038	38	65	17	22	28	34	1140	250	145	8	M6x20	14	M6	4	0,40
06130040	40	65	17	22	28	34	1200	235	145	8	M6x20	14	M6	4	0,40
06130045	45	75	20	25	33	41	2180	290	170	7	M8x25	35	M8	3	0,60
06130050	50	80	20	25	33	41	2430	260	160	7	M8x25	35	M8	3	0,80
06130055	55	85	20	25	33	41	3070	270	175	8	M8x25	35	M8	4	0,80
06130060	60	90	20	25	33	41	3350	245	165	8	M8x25	35	M8	4	0,80
06130065	65	95	20	25	33	41	4080	255	175	9	M8x25	35	M8	3	0,90
06130070	70	110	24	30	40	50	6280	280	180	8	M10x30	70	M10	4	1,59
06130075	75	115	24	30	40	50	6680	260	170	8	M10x30	70	M10	4	1,80
06130080	80	120	24	30	40	50	7130	250	160	8	M10x30	70	M10	4	1,80
06130085	85	125	24	30	40	50	8480	260	180	9	M10x30	70	M10	3	2,00
06130090	90	130	24	30	40	50	9080	250	170	9	M10x30	70	M10	3	2,10
06130095	95	135	24	30	40	50	10580	260	180	10	M10x30	70	M10	4	2,10
06130100	100	145	26	32	44	56	13380	270	190	8	M12x35	125	M12	4	2,80
06130110	110	155	26	32	44	56	14580	240	180	8	M12x35	125	M12	4	3,00
06130120	120	165	26	32	44	56	17880	250	180	9	M12x35	125	M12	4	3,20
06130130	130	180	34	40	52	64	26000	240	170	12	M12x35	125	M12	6	4,80
06130140	140	190	34	40	54	68	26980	210	150	9	M14x40	190	M14	4	5,20
06130150	150	200	34	40	54	68	32980	230	170	10	M14x40	190	M14	5	5,40
06130160	160	210	34	40	54	68	37980	230	170	11	M14x40	190	M14	4	5,70
06130170	170	225	44	50	64	78	44980	180	130	12	M14x40	190	M14	6	8,00
06130180	180	235	44	50	64	78	46980	170	130	12	M14x40	190	M14	6	0,30

ORDERING EXAMPLE:

The following will be ordered with a shaft having ød 30 with a torque value less than or equal 660 Nm:

RCK 13 - 30 x 55

Part Number 06130030

CAD drawings available on our site

www.chiaravalli.com

3D simulation available on the website.

Quantity, availability and prices on B2B Chiaravalli





SELF CENTRING

THE RECOMMENDED MACHINING TOLERANCES FOR THE PRESSURE SURFACES ARE AS FOLLOWS:

Ø h 8 FOR SHAFT

Ø H 8 FOR HUB

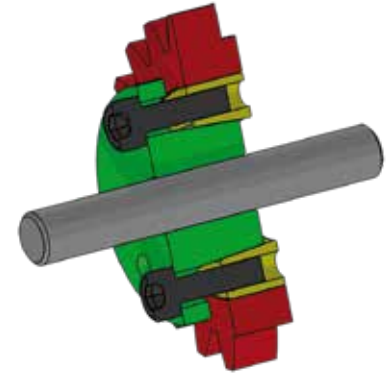
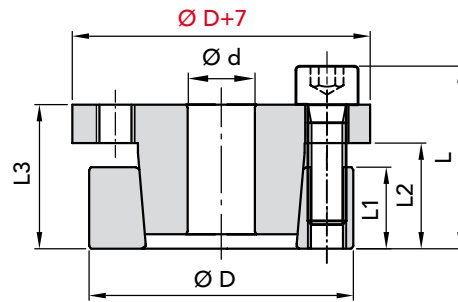

PART NUMBER	DIMENSIONS						maximum torque Mt Nm	CLAMPING PRESSURE		CLAMPING SCREWS DIN 912 MAT. 12.9			EXTRACTION THREAD		WEIGHT Kg
	Ød	ØD	L1	L2	L3	L		Shaft N/mm ²	Hub N/mm ²	N°	Ø x L	Torque Max Nm	Ø	N°	
06150014	14	55	17	22	31	39	290	458	118	4	M8x25	41	M8	2	0,50
06150016	16	55	17	22	31	39	320	400	118	4	M8x25	41	M8	2	0,50
06150018	18	55	17	22	31	39	360	356	118	4	M8x25	41	M8	2	0,50
06150019	19	55	17	22	31	39	380	337	118	4	M8x25	41	M8	2	0,50
06150020	20	55	17	22	31	39	400	320	118	4	M8x25	41	M8	2	0,50
06150022	22	55	17	22	31	39	440	290	118	4	M8x25	41	M8	2	0,50
06150024	24	55	17	22	31	39	480	265	118	4	M8x25	41	M8	2	0,50
06150025	25	55	17	22	31	39	500	255	118	4	M8x25	41	M8	2	0,50
06150028	28	55	17	22	31	39	560	228	118	4	M8x25	41	M8	2	0,40
06150030	30	55	17	22	31	39	600	213	118	4	M8x25	41	M8	2	0,40
06151024	24	65	17	22	31	39	620	332	122	5	M8x25	41	M8	3	0,70
06151025	25	65	17	22	31	39	640	320	122	5	M8x25	41	M8	3	0,70
06151028	28	65	17	22	31	39	720	285	122	5	M8x25	41	M8	3	0,60
06151030	30	65	17	22	31	39	770	267	122	5	M8x25	41	M8	3	0,60
06151032	32	65	17	22	31	39	820	250	122	5	M8x25	41	M8	3	0,60
06151033	33	65	17	22	31	39	850	235	122	5	M8x25	41	M8	3	0,60
06151035	35	65	17	22	31	39	900	228	122	5	M8x25	41	M8	3	0,50
06151038	38	65	17	22	31	39	980	210	122	5	M8x25	41	M8	3	0,50
06151040	40	65	17	22	31	39	1030	200	122	5	M8x25	41	M8	3	0,50
06152030	30	80	20	25	33	41	1080	315	120	7	M8x25	41	M8	3	1,00
06152032	32	80	20	25	33	41	1150	298	120	7	M8x25	41	M8	3	1,00
06152033	33	80	20	25	33	41	1200	282	120	7	M8x25	41	M8	3	1,00
06152035	35	80	20	25	33	41	1260	272	120	7	M8x25	41	M8	3	1,00
06152038	38	80	20	25	33	41	1370	250	120	7	M8x25	41	M8	3	1,00
06152040	40	80	20	25	33	41	1440	238	120	7	M8x25	41	M8	3	0,90
06152042	42	80	20	25	33	41	1510	226	120	7	M8x25	41	M8	3	0,90
06152045	45	80	20	25	33	41	1620	212	120	7	M8x25	41	M8	3	0,80
06152048	48	80	20	25	33	41	1730	198	120	7	M8x25	41	M8	3	0,80
06152050	50	80	20	25	33	41	1800	190	120	7	M8x25	41	M8	3	0,80
06153040	40	80	20	25	33	41	2150	340	169	10	M8x25	41	M8	4	0,95
06153045	45	80	20	25	33	41	2420	302	169	10	M8x25	41	M8	4	0,85
06153050	50	80	20	25	33	41	2700	272	169	10	M8x25	41	M8	4	0,85

ORDERING EXAMPLE:

The following will be ordered with a shaft having ϕd 40 with a torque value less than or equal 1030 Nm:

RCK 15 - 40 x 65

Part Number 06151040

CAD drawings available on our site
www.chiaravalli.com

3D simulation available on the website.



Quantity, availability and prices
 on B2B Chiaravalli



RCK 16 TYPE CLAMPING ELEMENTS

SELF CENTRING

THE RECOMMENDED MACHINING TOLERANCES FOR THE PRESSURE SURFACES ARE AS FOLLOWS:

Ø h 8 FOR SHAFT

Ø H 8 FOR HUB

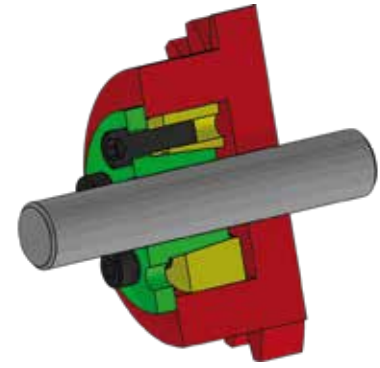
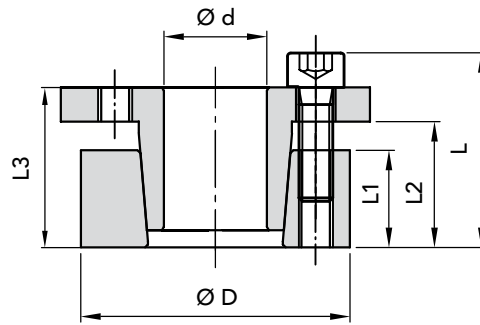

DIMENSIONS

PART NUMBER	Ød	ØD	L1	L2	L3	L	maximum torque Mt Nm	CLAMPING PRESSURE		CLAMPING SCREWS DIN 912 MAT. 12.9			EXTRACTION THREAD		WEIGHT Kg
								Shaft N/mm ²	Hub N/mm ²	N.	Type	Torque Nm	Type	N.	
06160018	18	47	17	22	28	34	260	240	93	5	M6x20	17	M6	3	0,30
06160019	19	47	17	22	28	34	270	230	93	5	M6x20	17	M6	3	0,30
06160020	20	47	17	22	28	34	280	220	95	5	M6x20	17	M6	3	0,30
06160022	22	47	17	22	28	34	300	200	95	5	M6x20	17	M6	3	0,30
06160024	24	50	17	22	28	34	400	215	107	6	M6x20	17	M6	3	0,30
06160025	25	50	17	22	28	34	420	210	105	6	M6x20	17	M6	3	0,30
06160028	28	55	17	22	28	34	470	190	96	6	M6x20	17	M6	3	0,40
06160030	30	55	17	22	28	34	500	180	95	6	M6x20	17	M6	3	0,40
06160032	32	60	17	22	28	34	720	220	115	8	M6x20	17	M6	4	0,40
06160035	35	60	17	22	28	34	790	200	115	8	M6x20	17	M6	4	0,40
06160038	38	65	17	22	28	34	850	185	105	8	M6x20	17	M6	4	0,50
06160040	40	65	17	22	28	34	900	175	105	8	M6x20	17	M6	4	0,50
06160045	45	75	20	25	33	41	1620	215	125	7	M8x25	41	M8	3	0,70
06160050	50	80	20	25	33	41	1820	195	120	7	M8x25	41	M8	3	0,80
06160055	55	85	20	25	33	41	2300	200	130	8	M8x25	41	M8	4	0,90
06160060	60	90	20	25	33	41	2500	185	125	8	M8x25	41	M8	4	0,90
06160065	65	95	20	25	33	41	3050	190	130	9	M8x25	41	M8	3	1,00
06160070	70	110	24	30	40	50	4660	210	135	8	M10x30	83	M10	4	1,90
06160075	75	115	24	30	40	50	5000	195	125	8	M10x30	83	M10	4	2,00
06160080	80	120	24	30	40	50	5300	185	125	8	M10x30	83	M10	4	2,00
06160085	85	125	24	30	40	50	6350	195	135	9	M10x30	83	M10	3	2,00
06160090	90	130	24	30	40	50	6760	185	130	9	M10x30	83	M10	3	2,20
06160095	95	135	24	30	40	50	7900	195	135	10	M10x30	83	M10	4	2,30
06160100	100	145	26	32	44	56	9700	200	140	8	M12x35	145	M12	4	3,00
06160110	110	155	26	32	44	56	10600	180	130	8	M12x35	145	M12	4	3,20
06160120	120	165	26	32	44	56	13000	185	135	9	M12x35	145	M12	4	3,40
06160130	130	180	34	40	52	64	18900	175	125	12	M12x35	145	M12	6	5,20
06160140	140	190	34	40	54	68	20600	165	120	9	M14x40	230	M14	4	5,40
06160150	150	200	34	40	54	68	25100	175	130	10	M14x40	230	M14	5	5,70
06160160	160	210	34	40	54	68	29100	180	135	11	M14x40	230	M14	4	6,00
06160170	170	225	44	50	64	78	34100	140	105	12	M14x40	230	M14	6	8,30
06160180	180	235	44	50	64	78	36100	135	105	12	M14x40	230	M14	6	8,80

ORDERING EXAMPLE:

The following will be ordered with a shaft having ød 75 with a torque value less than or equal 5000 Nm:

RCK 16 - 75 x 115

Part Number 06160075

CAD drawings available on our site
www.chiaravalli.com

3D simulation available on the website.

Quantity, availability and prices
on B2B Chiaravalli





SELF CENTRING

THE RECOMMENDED MACHINING TOLERANCES FOR THE PRESSURE SURFACES ARE AS FOLLOWS:

Ød h 8 DIAMETER

IMPORTANT:

INTERN TAPERS ARE LUBRICATED WITH PRODUCTS BASED ON MOLYBDENUM BISULPHIDE.

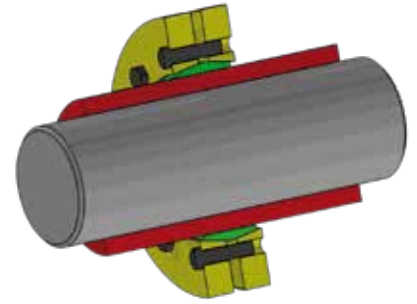
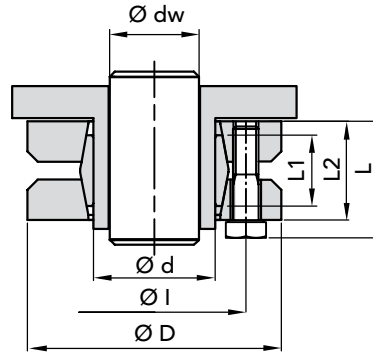

PART NUMBER	DIMENSIONS							Øl	Ødw (dw-d1)	maximum torque Mt Nm	CLAMPING PRESSURE Shaft N/mm ²	CLAMPING SCREWS DIN 931 MAT. 10.9			WEIGHT Kg
	Ød	ØD	Ødw	L1	L2	L	N.					Type	Torque Nm		
06190024	24	50	19 20 21	14	19,5	23	36	0,017	170 210 250	286	6	M5x18	4	0,20	
06190030	30	60	24 25 26	16	21,5	25	44	0,017	300 340 380	233	7	M5x18	4	0,30	
06190036	36	72	28 30 31	18	23,5	27,5	52	0,032	440 570 630	307	5	M6x20	12	0,40	
06190044	44	80	32 35 36	20	25,5	29,5	61	0,032	620 780 860	317	7	M6x20	12	0,60	
06190050	50	90	38 40 42	22	27,5	31,5	70	0,032	940 1160 1380	289	8	M6x25	12	0,80	
06190055	55	100	42 45 48	23	30,5	34,5	75	0,032	1160 1520 1880	252	8	M6x25	12	1,10	
06190062	62	110	48 50 52	23	30,5	34,5	86	0,048	1850 2200 2400	279	10	M6x25	12	1,30	
06190068	68	115	50 55 60	23	30,5	34,5	86	0,048	2000 2500 3150	255	10	M6x25	12	1,40	
06190075	75	138	55 60 65	25	32,5	37,8	100	0,048	2500 3200 3950	273	7	M8x30	30	1,70	
06190080	80	145	60 65 70	25	32,5	37,8	100	0,048	3200 3900 4600	256	7	M8x30	30	1,90	
06190090	90	155	65 70 75	30	39	44,3	114	0,048	4750 6000 7250	271	10	M8x35	30	3,30	
06190100	100	170	70 75 80	34	44	49,3	124	0,048	6900 7500 9000	258	12	M8x35	30	4,70	
06190110	110	185	75 80 85	39	50	56,4	136	0,048	7200 9000 10800	244	9	M10x40	59	5,90	
06190125	125	215	85 90 95	42	54	60,4	160	0,069	11000 13000 15000	266	12	M10x40	59	8,30	
06190140	140	230	95 100 105	46	60,5	68	175	0,069	15100 17600 20100	264	10	M12x45	100	10,0	
06190155	155	265	105 110 115	50	64,5	72	192	0,069	22000 25000 28000	263	12	M12x50	100	15,0	
06190165	165	290	115 120 125	56	71	81	210	0,069	31000 35000 39000	277	8	M16x55	250	22,0	
06190175	175	300	125 130 135	56	71	81	220	0,079	36000 41000 45000	261	8	M16x55	250	22,0	
06190185	185	330	135 140 145	71	86	96	236	0,09	52000 57000 62000	237	10	M16x70	250	24,0	

ORDERING EXAMPLE:

The following will be ordered with a shaft having Ød 36 with a torque value less than or equal 440 Nm:

RCK 19 - 36 x 72

Part Number 06190036

CAD drawings available on our site
www.chiaravalli.com

3D simulation available on the website.

Quantity, availability and prices
on B2B Chiaravalli





RCK 40 TYPE CLAMPING ELEMENTS

NOT SELF CENTERING

THE RECOMMENDED MACHINING TOLERANCES FOR THE PRESSURE SURFACES ARE AS FOLLOWS:

$\varnothing h 8$ FOR SHAFT

$\varnothing H 8$ FOR HUB

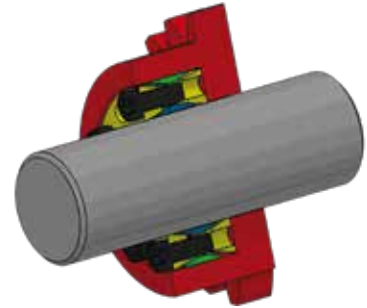
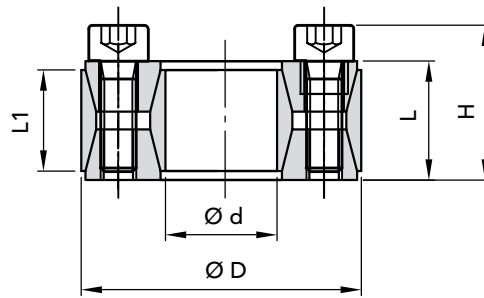

DIMENSIONS

PART NUMBER	Ød	ØD	L1	L	H	maximum torque Mt Nm	CLAMPING PRESSURE		CLAMPING SCREWS DIN 912 MAT. 12.9			EXTRACTION THREAD		WEIGHT Kg
							Shaft N/mm ²	Hub N/mm ²	N.	Type	Torque Nm	Type	N.	
06400019	19	47	17	20	28	255	220	90	8	M6x18	14	M8	2	0,25
06400020	20	47	17	20	28	270	210	90	8	M6x18	14	M8	2	0,24
06400022	22	47	17	20	28	300	195	90	8	M6x18	14	M8	2	0,23
06400024	24	50	17	20	28	360	195	95	9	M6x18	14	M8	3	0,26
06400025	25	50	17	20	28	380	190	95	9	M6x18	14	M8	3	0,25
06400028	28	55	17	20	28	500	187	96	10	M6x18	14	M8	4	0,27
06400030	30	55	17	20	28	530	176	96	10	M6x18	14	M8	4	0,27
06400032	32	60	17	20	28	630	192	105	12	M6x18	14	M8	4	0,32
06400035	35	60	17	20	28	700	180	105	12	M6x18	14	M8	4	0,32
06400038	38	65	17	20	28	860	183	107	14	M6x18	14	M8	4	0,36
06400040	40	65	17	20	28	910	180	110	14	M6x18	14	M8	4	0,34
06400042	42	75	20	24	34	1500	226	125	12	M8x22	35	M10	4	0,48
06400045	45	75	20	24	34	1610	210	125	12	M8x22	35	M10	4	0,57
06400048	48	80	20	24	34	1700	196	115	12	M8x22	35	M10	4	0,59
06400050	50	80	20	24	34	1770	190	115	12	M8x22	35	M10	4	0,60
06400055	55	85	20	24	34	2270	200	130	14	M8x22	35	M10	4	0,63
06400060	60	90	20	24	34	2470	180	120	14	M8x22	35	M10	4	0,69
06400065	65	95	20	24	34	3040	190	130	16	M8x22	35	M12	4	0,73
06400070	70	110	24	28	40	4600	210	130	14	M10x25	70	M12	4	1,26
06400075	75	115	24	28	40	4900	195	125	14	M10x25	70	M12	4	1,33
06400080	80	120	24	28	40	5200	180	120	14	M10x25	70	M12	4	1,40
06400085	85	125	24	28	40	6300	195	130	16	M10x25	70	M12	4	1,49
06400090	90	130	24	28	40	6600	180	125	16	M10x25	70	M12	4	1,53
06400095	95	135	24	28	40	7900	195	135	18	M10x25	70	M12	4	1,62
06400100	100	145	26	33	47	9600	195	135	14	M12x30	125	M14	4	2,01
06400110	110	155	26	33	47	10500	180	125	14	M12x30	125	M14	4	2,15
06400120	120	165	26	33	47	13100	185	135	16	M12x30	125	M14	4	2,35
06400130	130	180	34	38	52	17600	165	115	20	M12x35	125	M14	4	3,51
06400140	140	190	34	38	52	20900	165	125	22	M12x35	125	M14	4	3,85
06400150	150	200	34	38	52	24200	170	125	24	M12x35	125	M14	4	4,07
06400160	160	210	34	38	52	28000	170	130	26	M12x35	125	M14	4	4,30
06400170	170	225	38	44	60	32800	160	120	22	M14x40	190	M16	4	5,80
06400180	180	235	38	44	60	37800	165	125	24	M14x40	190	M16	4	6,00
06400190	190	250	46	52	68	46500	150	115	28	M14x45	190	M16	4	8,50
06400200	200	260	46	52	68	52500	150	115	30	M14x45	190	M16	5	8,60
06400220	220	285	50	56	74	68000	150	115	26	M16x50	295	M18	3	11,0

ORDERING EXAMPLE:

The following will be ordered with a shaft having Ød 75 with a torque value less than or equal 4900 Nm:

RCK 40 - 75 x 115

Part Number 06400075

CAD drawings available on our site
www.chiaravalli.com

3D simulation available on the website.

Quantity, availability and prices
on B2B Chiaravalli





NOT SELF CENTERING

THE RECOMMENDED MACHINING TOLERANCES FOR THE PRESSURE SURFACES ARE AS FOLLOWS:

$\varnothing h 8$ FOR SHAFT

$\varnothing H 8$ FOR HUB

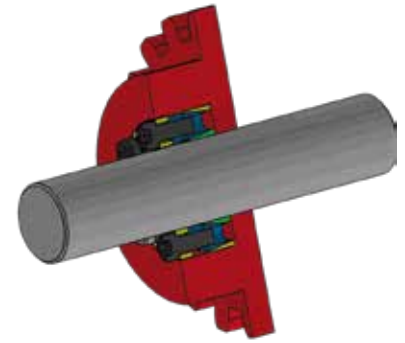
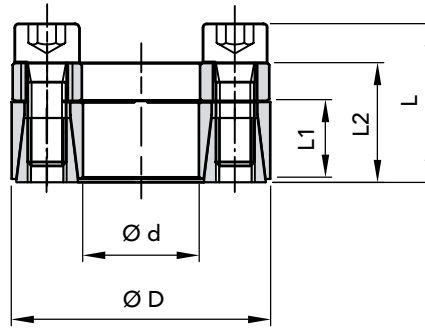

PART NUMBER	DIMENSIONS					maximum torque Mt Nm	CLAMPING PRESSURE		CLAMPING SCREWS DIN 912 MAT. 12.9			EXTRACTION THREAD		WEIGHT Kg
	Ød	ØD	L1	L2	L		Shaft N/mm ²	Hub N/mm ²	N.	Type	Torque Nm	Type	N.	
06450018	18	40	12	18,5	24,5	190	260	120	6	M6x16	16	M8	2	0,20
06450019	19	41	12	18,5	24,5	210	260	120	6	M6x16	16	M8	2	0,25
06450020	20	42	12	18,5	24,5	240	250	120	6	M6x16	16	M8	2	0,24
06450024	24	46	12	18,5	24,5	290	250	120	6	M6x16	16	M8	2	0,25
06450025	25	47	12	18,5	24,5	330	230	120	8	M6x16	16	M8	2	0,25
06450028	28	50	12	18,5	24,5	370	220	120	8	M6x16	16	M8	2	0,30
06450030	30	52	12	18,5	24,5	430	210	120	8	M6x16	16	M8	2	0,30
06450035	35	57	15	22	28	610	170	100	12	M6x16	16	M8	3	0,32
06450038	38	60	15	22	28	680	170	100	12	M6x16	16	M8	3	0,36
06450040	40	62	15	22	28	780	170	100	12	M6x16	16	M8	3	0,40
06450042	42	70	18	28	36	1480	190	110	12	M8x22	41	M10	3	0,45
06450045	45	73	18	28	36	1500	210	130	12	M8x22	41	M10	3	0,57
06450048	48	76	18	28	36	1550	210	130	12	M8x22	41	M10	3	0,59
06450050	50	78	18	28	36	1650	190	120	12	M8x22	41	M10	3	0,61
06450055	55	83	18	28	36	2000	190	120	16	M8x22	41	M10	4	0,63
06450060	60	88	18	28	36	2350	190	120	16	M8x22	41	M10	4	0,69
06450070	70	105	22	35	35	3900	180	120	12	M10x25	70	M12	3	1,25
06450080	80	115	22	35	35	4800	170	120	16	M10x25	70	M12	4	1,40

ORDERING EXAMPLE:

The following will be ordered with a shaft having $\varnothing d$ 55 with a torque value less than or equal 2000 Nm:

RCK 45 - 55 x 83

Part Number 06450055

CAD drawings available on our site

www.chiaravalli.com

3D simulation available on the website.

Quantity, availability and prices on B2B Chiaravalli

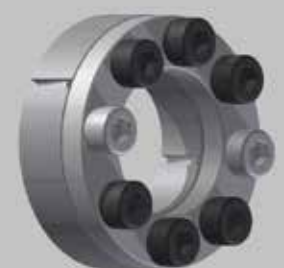



RCK 50 TYPE CLAMPING ELEMENTS

13

NOT SELF CENTERING

THE RECOMMENDED MACHINING TOLERANCES FOR THE PRESSURE SURFACES ARE AS FOLLOWS:

Ø h 8 FOR SHAFT

Ø H 8 FOR HUB

* cut horizontally

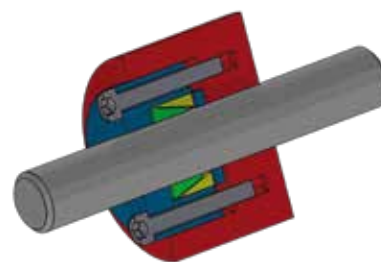
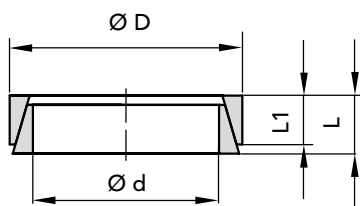

RCK 50 TYPE CLAMPING ELEMENTS

PART NUMBER	DIMENSIONS				Necessary force Kg	maximum torque Mt Nm	CLAMPING PRESSURE		WEIGHT Kg
	Ød	ØD	L1	L			Shaft N/mm ²	Hub N/mm ²	
06500006	*6	9	3,7	4,5	380	2,4	115	75	0,01
06500007	*7	10	3,7	4,5	390	3,0	105	70	0,01
06500008	*8	11	3,7	4,5	530	4,7	120	90	0,01
06500009	9	12	3,7	4,5	1560	7,9	140	105	0,01
06500010	10	13	3,7	4,5	1560	9,5	135	105	0,01
06500012	12	15	3,7	4,5	1560	11,4	115	90	0,01
06500013	13	16	3,7	4,5	1560	13,1	110	90	0,01
06500014	14	18	5,3	6,3	2540	22,3	115	90	0,01
06500015	15	19	5,3	6,3	2540	24,3	110	85	0,01
06500016	16	20	5,3	6,3	2540	27,3	105	85	0,01
06500017	17	21	5,3	6,3	2540	29,8	105	85	0,01
06500018	18	22	5,3	6,3	2540	32,4	100	80	0,01
06500019	19	24	5,3	6,3	3600	49	140	110	0,01
06500020	20	25	5,3	6,3	3600	53	135	105	0,01
06500022	22	26	5,3	6,3	3600	66	135	115	0,01
06500024	24	28	5,3	6,3	3600	73	130	110	0,01
06500025	25	30	5,3	6,3	3600	72	115	95	0,01
06500028	28	32	5,3	6,3	3600	86	115	100	0,01
06500030	30	35	5,3	6,3	3600	91	100	85	0,01
06500032	32	36	5,3	6,3	4500	131	130	115	0,02
06500035	35	40	6	7	5400	171	125	110	0,02
06500036	36	42	6	7	5400	169	115	100	0,02
06500038	38	44	6	7	5400	181	110	95	0,02
06500040	40	45	6,6	8	6600	231	115	105	0,03
06500042	42	48	6,6	8	6600	235	110	95	0,04
06500045	45	52	8,6	10	9900	353	105	95	0,04
06500048	48	55	8,6	10	13200	572	155	135	0,05
06500050	50	57	8,6	10	13200	602	150	130	0,05
06500055	55	62	8,6	10	13200	670	140	125	0,06
06500056	56	64	10,4	12	15720	790	130	115	0,07
06500060	60	68	10,4	12	15720	860	125	110	0,07
06500063	63	71	10,4	12	15720	910	120	105	0,08
06500065	65	73	10,4	12	15720	950	115	100	0,08
06500070	70	79	12,2	14	20960	1380	125	110	0,11
06500071	71	80	12,2	14	20960	1400	120	110	0,12
06500075	75	84	12,2	14	20960	1450	115	100	0,12
06500080	80	91	15	17	29000	2200	125	105	0,20

ORDERING EXAMPLE:

The following will be ordered with a shaft having Ød 24 with a torque value less than or equal 73 Nm:

RCK 50 - 24 x 28

Part Number 06500024

CAD drawings available on our site
www.chiaravalli.com

3D simulation available on the website.

Quantity, availability and prices on B2B Chiaravalli





SELF CENTRING

THE RECOMMENDED MACHINING TOLERANCES FOR THE PRESSURE SURFACES ARE AS FOLLOWS:

$\varnothing h 8$ FOR SHAFT

$\varnothing H 8$ FOR HUB

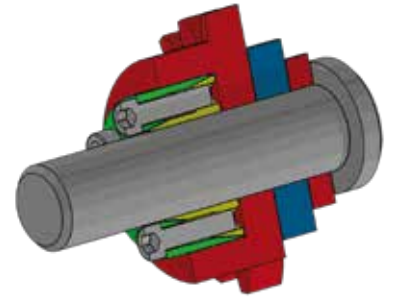
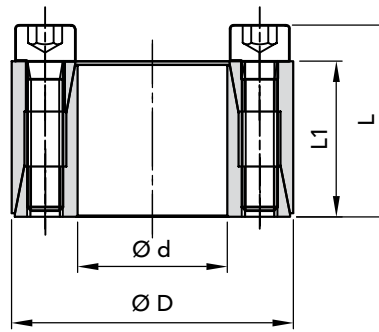

PART NUMBER	DIMENSIONS				maximum torque Mt Nm	CLAMPING PRESSURE		CLAMPING SCREWS DIN 912 MAT. 12.9			EXTRACTION THREAD		WEIGHT Kg
	Ød	ØD	L1	L		Shaft N/mm ²	Hub N/mm ²	N.	Type	Torque Nm	Type	N.	
06610010	10	20	13	15,5	15	110	55	4	M2,5x12	1,2	M2,5	2	0,02
06610012	12	22	13	15,5	20	90	50	4	M2,5x12	1,2	M2,5	2	0,02
06610014	14	26	17	20	35	105	55	4	M3x16	2,1	M3	2	0,04
06610015	15	28	17	20	40	100	50	4	M3x16	2,1	M3	2	0,04
06610016	16	32	17	21	70	130	65	4	M4x16	4,9	M4	2	0,07
06610018	18	35	21	25	80	115	60	4	M4x20	4,9	M4	2	0,09
06610019	19	35	21	25	85	110	60	4	M4x20	4,9	M4	2	0,08
06610020	20	38	21	26	220	220	115	6	M5x20	9,7	M5	3	0,10
06610022	22	40	21	26	240	200	110	6	M5x20	9,7	M5	3	0,11
06610024	24	47	26	32	380	220	110	6	M6x25	16,2	M6	3	0,20
06610025	25	47	26	32	390	210	110	6	M6x25	16,2	M6	3	0,19

ORDERING EXAMPLE:

The following will be ordered with a shaft having $\varnothing d$ 15 with a torque value less than or equal 40 Nm:

RCK 61 - 15 x 28

Part Number 06610015

CAD drawings available on our site
www.chiaravalli.com

3D simulation available on the website.

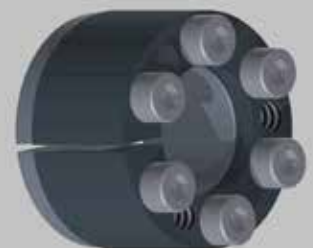

Quantity, availability and prices
on B2B Chiaravalli



RCK 70 TYPE CLAMPING ELEMENTS

SELF CENTRING

THE RECOMMENDED MACHINING TOLERANCES FOR THE PRESSURE SURFACES ARE AS FOLLOWS:

Ø h 8 FOR SHAFT

Ø H 8 FOR HUB

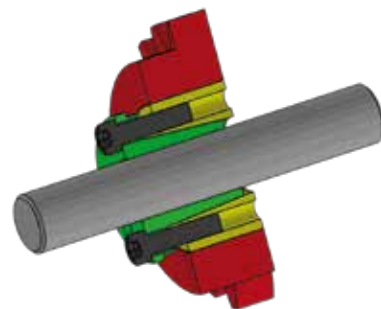
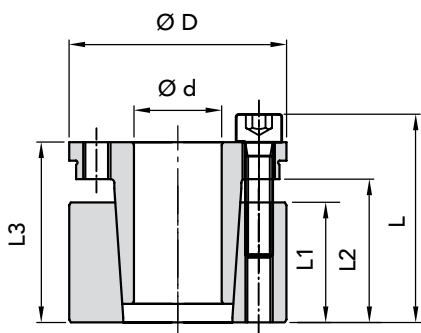

DIMENSIONS

PART NUMBER	Ød	ØD	DIMENSIONS				maximum torque Mt Nm	CLAMPING PRESSURE		CLAMPING SCREWS DIN 912 MAT. 12.9			EXTRACTION THREAD		WEIGHT Kg
			L1	L2	L3	L		Shaft N/mm ²	Hub N/mm ²	N.	Type	Torque Nm	Type	N.	
06700019	19	47	26	31	39	45	350	228	98	4	M6x25	17	M6	2	0,39
06700020	20	47	26	31	39	45	390	231	100	4	M6x25	17	M6	2	0,38
06700022	22	47	26	31	39	45	440	220	95	4	M6x25	17	M6	2	0,37
06700024	24	50	26	31	39	45	519	215	102	6	M6x25	17	M6	3	0,43
06700025	25	50	26	31	39	45	590	230	105	6	M6x25	17	M6	3	0,42
06700028	28	55	26	31	39	45	700	220	110	6	M6x25	17	M6	3	0,45
06700030	30	55	26	31	39	45	760	200	120	6	M6x25	17	M6	3	0,45
06700032	32	60	26	31	39	45	930	230	114	8	M6x25	17	M6	4	0,60
06700035	35	60	26	31	39	45	1030	200	119	8	M6x25	17	M6	4	0,50
06700038	38	65	26	31	39	45	1240	210	124	8	M6x25	17	M6	4	0,60
06700040	40	65	26	31	39	45	1350	200	125	8	M6x25	17	M6	4	0,60
06700042	42	75	30	36	47	55	2170	236	140	6	M8x30	41	M8	3	1,00
06700045	45	75	30	36	47	55	2350	236	140	6	M8x30	41	M8	3	1,00
06700048	48	80	30	36	47	55	2510	218	135	6	M8x30	41	M8	3	1,10
06700050	50	80	30	36	47	55	2580	218	135	6	M8x30	41	M8	3	1,00
06700055	55	85	30	36	47	55	3200	223	145	8	M8x30	41	M8	4	1,10
06700060	60	90	30	36	47	55	3380	198	157	8	M8x30	41	M8	4	1,20
06700065	65	95	30	36	47	55	4160	213	140	8	M8x30	41	M8	4	1,30
06700070	70	110	40	46	57	67	6840	225	143	8	M10x35	83	M10	4	2,20
06700075	75	115	40	46	62	72	7500	210	138	8	M10x35	83	M10	4	2,50
06700080	80	120	40	46	62	72	8100	200	130	8	M10x35	83	M10	4	2,60
06700085	85	125	40	46	62	72	9700	210	145	10	M10x35	83	M10	4	2,80
06700090	90	130	40	46	62	72	10300	200	138	10	M10x35	83	M10	4	2,70
06700095	95	135	40	46	62	72	12100	210	148	10	M10x35	83	M10	4	2,90
06700100	100	145	46	52	77	89	15700	216	148	8	M12x45	145	M12	4	3,90
06700110	110	155	46	52	77	89	17200	196	139	8	M12x45	145	M12	4	4,20
06700120	120	165	46	52	77	89	22500	216	156	10	M12x45	145	M12	4	4,80
06700130	130	180	46	52	77	89	24000	196	140	12	M12x45	145	M12	4	5,00
06700140	140	190	51	59	84	90	30800	196	145	8	M14x45	230	M14	4	6,50
06700150	150	200	51	59	84	90	37150	205	153	10	M14x45	230	M14	5	7,00
06700160	160	210	51	59	84	90	40500	205	155	10	M14x45	230	M14	5	7,00
06700170	170	225	51	59	84	90	40900	163	123	12	M14x45	230	M14	6	8,50
06700180	180	235	51	59	84	90	41300	160	120	12	M14x45	230	M14	6	9,00

ORDERING EXAMPLE:

The following will be ordered with a shaft having Ød 48 with a torque value less than or equal 2510 Nm:

RCK 70 - 48 x 80

Part Number 06700048

CAD drawings available on our site

www.chiaravalli.com

3D simulation available on the website.

Quantity, availability and prices on B2B Chiaravalli





SELF CENTRING

THE RECOMMENDED MACHINING TOLERANCES FOR THE PRESSURE SURFACES ARE AS FOLLOWS:

$\varnothing h 8$ FOR SHAFT

$\varnothing H 8$ FOR HUB

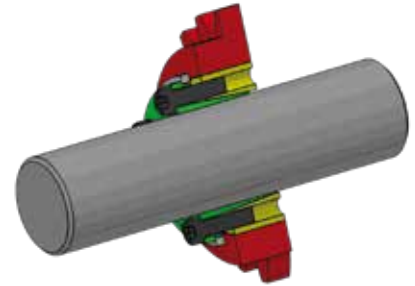
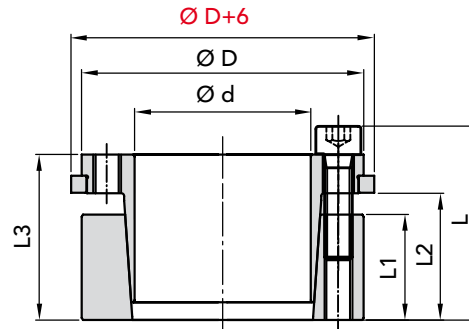

PART NUMBER	DIMENSIONS						maximum torque Mt Nm	CLAMPING PRESSURE		CLAMPING SCREWS DIN 912 MAT. 12.9			EXTRACTION THREAD		WEIGHT Kg
	Ød	ØD	L1	L2	L3	L		Shaft N/mm ²	Hub N/mm ²	N.	Type	Torque Nm	Type	N.	
06710019	19	47	26	31	39	45	300	228	98	4	M6x25	17	M6	2	0,45
06710020	20	47	26	31	39	45	320	231	98	4	M6x25	17	M6	2	0,46
06710022	22	47	26	31	39	45	370	211	99	4	M6x25	17	M6	2	0,50
06710024	24	50	26	31	39	45	430	220	110	6	M6x25	17	M6	3	0,50
06710025	25	50	26	31	39	45	480	226	113	6	M6x25	17	M6	3	0,50
06710028	28	55	26	31	39	45	590	207	108	6	M6x25	17	M6	3	0,60
06710030	30	55	26	31	39	45	650	226	121	6	M6x25	17	M6	3	0,60
06710032	32	60	26	31	39	45	800	201	117	8	M6x25	17	M6	4	0,70
06710035	35	60	26	31	39	45	860	206	121	8	M6x25	17	M6	4	0,60
06710038	38	65	26	31	39	45	1030	201	124	8	M6x25	17	M6	4	0,80
06710040	40	65	26	31	39	45	1130	239	146	8	M6x25	17	M6	4	0,60
06710042	42	75	30	36	47	55	1930	221	138	6	M8x30	41	M8	3	1,20
06710045	45	75	30	36	47	55	1950	221	138	6	M8x30	41	M8	3	1,10
06710048	48	80	30	36	47	55	2180	226	145	6	M8x30	41	M8	3	1,30
06710050	50	80	30	36	47	55	2210	226	146	6	M8x30	41	M8	3	1,10
06710055	55	85	30	36	47	55	2730	226	146	8	M8x30	41	M8	4	1,20
06710060	60	90	30	36	47	55	2910	201	134	8	M8x30	41	M8	4	1,30
06710065	65	95	30	36	47	55	3570	211	145	8	M8x30	41	M8	4	1,40
06710070	70	110	40	46	57	67	5830	226	145	8	M10x35	83	M10	4	2,50
06710075	75	115	40	46	62	72	6330	221	151	8	M10x35	83	M10	4	2,60
06710080	80	120	40	46	62	72	6840	202	142	8	M10x35	83	M10	4	2,80
06710085	85	125	40	46	62	72	8160	221	161	10	M10x35	83	M10	4	2,80
06710090	90	130	40	46	62	72	8670	201	146	10	M10x35	83	M10	4	3,00
06710095	95	135	40	46	62	72	10200	191	141	10	M10x35	83	M10	4	3,00
06710100	100	145	46	52	77	89	13600	201	151	8	M12x45	145	M12	4	5,50
06710110	110	155	46	52	77	89	14870	201	182	8	M12x45	145	M12	4	4,80
06710120	120	165	46	52	77	89	19460	221	162	10	M12x45	145	M12	4	5,50
06710130	130	180	46	52	77	89	20820	202	146	12	M12x45	145	M12	4	6,00
06710140	140	190	51	59	84	90	25410	192	141	8	M14x45	230	M14	4	7,50
06710150	150	200	51	59	84	90	30720	202	152	10	M14x45	230	M14	5	7,70
06710160	160	210	51	59	84	90	33150	202	152	10	M14x45	230	M14	5	8,00
06710170	170	225	51	59	84	90	34000	161	121	12	M14x45	230	M14	6	9,80
06710180	180	235	51	59	84	90	34250	157	122	12	M14x45	230	M14	6	9,80

ORDERING EXAMPLE:

The following will be ordered with a shaft having Ød 30 with a torque value less than or equal 650 Nm:

RCK 71 - 30 x 55

Part Number 06710030

CAD drawings available on our site

www.chiaravalli.com

3D simulation available on the website.



Quantity, availability and prices on B2B Chiaravalli



RCK 80 TYPE CLAMPING ELEMENTS

SELF CENTRING

THE RECOMMENDED MACHINING TOLERANCES FOR THE PRESSURE SURFACES ARE AS FOLLOWS:

Ø h 8 FOR SHAFT

Ø H 8 FOR HUB

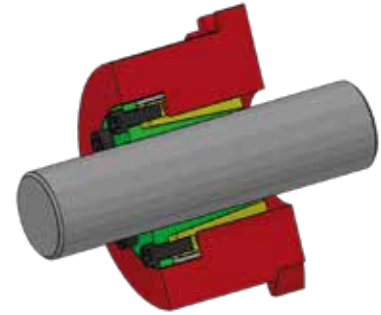
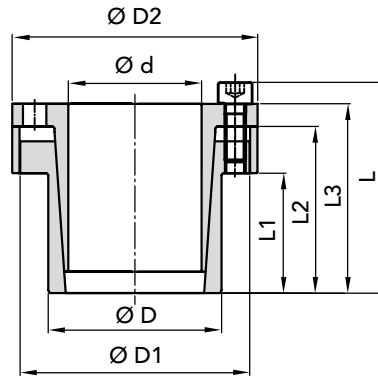

DIMENSIONS

PART NUMBER	Ød	ØD	ØD1	ØD2	L1	L2	L3	L	maximum torque	CLAMPING PRESSURE		CLAMPING SCREWS DIN 912 MAT. 12.9			EXTRACTION THREAD		WEIGHT Kg
									Mt Nm	Shaft N/mm ²	Hub N/mm ²	N.	Type	Torque Nm	Type	N.	
06800006	6	14	22	25	10	18,5	22,5	25,5	12	190	80	3	M3x10	2,2	M3	2	0,10
06800008	8	15	24	27	12	21,5	25,5	29,5	29	205	110	3	M4x12	5	M4	2	0,10
06800009	9	16	25	28	14	23,5	27,5	31,5	31	150	85	3	M4x12	5	M4	2	0,10
06800010	10	16	25	28	14	23,5	27,5	31,5	35	140	85	3	M4x12	5	M4	2	0,11
06800011	11	18	28	32	14	23,5	27,5	31,5	52	170	105	4	M4x12	5	M4	2	0,11
06800012	12	18	28	32	14	23,5	27,5	31,5	58	150	100	4	M4x12	5	M4	2	0,12
06800014	14	23	35	39	14	23,5	27,5	31,5	69	140	80	4	M4x12	5	M4	2	0,12
06800015	15	24	40	45	16	29,5	36,5	42,5	170	158	98	4	M6x18	17	M6	2	0,21
06800016	16	24	40	45	16	29,5	36,5	42,5	180	148	98	4	M6x18	17	M6	2	0,23
06800017	17	26	42	47	19	32,5	39,5	45,5	200	180	125	4	M6x18	17	M6	2	0,25
06800018	18	26	42	47	19	32,5	39,5	45,5	200	180	125	4	M6x18	17	M6	2	0,27
06800019	19	27	43	49	19	32,5	39,5	45,5	210	170	120	4	M6x18	17	M6	2	0,27
06800020	20	28	44	50	19	32,5	39,5	45,5	220	160	115	4	M6x18	17	M6	2	0,27
06800022	22	32	48	54	26	39,5	46,5	52,5	250	115	80	4	M6x18	17	M6	2	0,38
06800024	24	34	50	56	26	39,5	46,5	52,5	395	146	102	6	M6x18	17	M6	3	0,41
06800025	25	34	50	56	26	39,5	46,5	52,5	410	140	102	6	M6x18	17	M6	3	0,45
06800028	28	39	55	61	25,5	39,5	46,5	52,5	465	135	98	6	M6x18	17	M6	3	0,47
06800030	30	41	57	62	25,5	39,5	46,5	52,5	510	127	90	6	M6x18	17	M6	3	0,48
06800032	32	43	59	65	25,5	39,5	46,5	52,5	705	146	108	8	M6x18	17	M6	4	0,49
06800035	35	47	62	69	31,5	45,5	52,5	58,5	790	105	80	8	M6x18	17	M6	4	0,63
06800038	38	50	66	72	31,5	45,5	52,5	58,5	860	100	76	8	M6x18	17	M6	4	0,67
06800040	40	53	69	75	31,5	45,5	52,5	58,5	900	96	72	8	M6x18	17	M6	4	0,73
06800042	42	55	71	78	31,5	45,5	52,5	58,5	940	90	70	8	M6x18	17	M6	4	0,78
06800045	45	59	80	86	45	62,5	71	79	1840	110	85	8	M8x22	41	M8	4	1,23
06800048	48	62	81	87	45	62,5	71	79	2000	105	80	8	M8x22	41	M8	4	1,24
06800050	50	65	86	92	45	62,5	71	79	2100	100	75	8	M8x22	41	M8	4	1,40
06800055	55	71	92	98	55	72,5	81	89	2580	85	65	9	M8x22	41	M8	3	1,70
06800060	60	77	98	104	55	72,5	81	89	2800	75	60	9	M8x22	41	M8	3	1,76
06800065	65	84	105	111	55	72,5	81	89	3050	70	55	9	M8x22	41	M8	3	2,21
06800070	70	90	113	119	65	86,5	96,5	106,5	5250	90	70	9	M10x25	83	M10	3	3,05
06800075	75	95	119	126	65	86,5	96,5	106,5	5600	80	65	9	M10x25	83	M10	3	3,32
06800080	80	100	125	131	65	86,5	96,5	106,5	8000	100	80	12	M10x25	83	M10	4	3,50
06800090	90	112	137	144	65	86,5	96,5	106,5	9000	90	75	12	M10x25	83	M10	4	3,90
06800100	100	125	147	154	65	86,5	96,5	106,5	15000	120	95	18	M10x25	83	M10	4	4,60
06800110	110	140	172	180	90	114	128	140	16000	80	65	12	M12x35	145	M12	4	8,70
06800120	120	155	187	198	90	114	128	140	17500	70	55	12	M12x35	145	M12	4	10,70

ORDERING EXAMPLE:

The following will be ordered with a shaft having Ød 95 with a torque value less than or equal 8000 Nm:

RCK 80 - 80 x 100

Part Number 06800080

CAD drawings available on our site

www.chiaravalli.com

3D simulation available on the website.

Quantity, availability and prices on B2B Chiaravalli

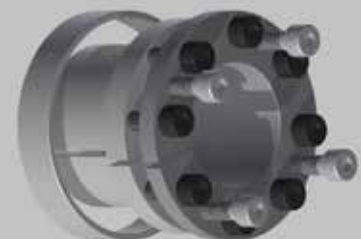



RIGID JOINT

THE RECOMMENDED MACHINING TOLERANCES FOR THE PRESSURE SURFACES ARE AS FOLLOWS:

Ø h 8 FOR SHAFT

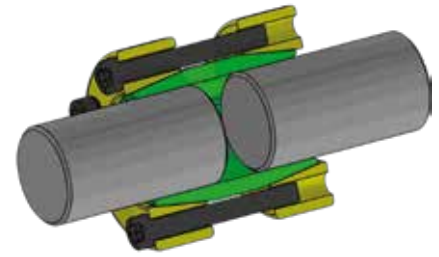
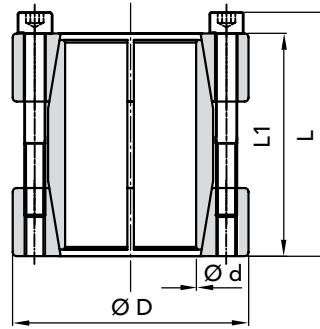

PART NUMBER	DIMENSIONS				maximum torque Mt Nm	CLAMPING PRESSURE Shaft N/mm ² ²	CLAMPING SCREWS DIN 912 MAT. 12.9			WEIGHT Kg
	Ød	ØD	L1	L			N.	Type	Torque Nm	
06950017	17	50	50	56	200	110	4	M6x40	17	0,51
06950018	18	50	50	56	220	110	4	M6x40	17	0,52
06950019	19	50	50	56	230	110	4	M6x40	17	0,50
06950020	20	50	50	56	240	105	4	M6x40	17	0,50
06950024	24	55	60	66	290	120	4	M6x50	17	0,71
06950025	25	55	60	66	450	110	6	M6x50	17	0,69
06950028	28	60	60	66	510	110	6	M6x50	17	0,81
06950030	30	60	60	66	550	105	6	M6x50	17	0,78
06950032	32	63	60	66	580	90	6	M6x50	17	0,85
06950035	35	75	75	83	790	105	4	M8x60	41	1,48
06950038	38	75	75	83	850	100	4	M8x60	41	1,45
06950040	40	75	75	83	900	95	4	M8x60	41	1,40
06950042	42	78	75	83	950	90	4	M8x60	41	1,50
06950045	45	85	85	93	1520	110	6	M8x70	41	2,03
06950048	48	90	85	93	1620	100	6	M8x70	41	2,24
06950050	50	90	85	93	1690	95	6	M8x70	41	2,18
06950055	55	94	85	93	2470	110	8	M8x70	41	2,29
06950060	60	100	85	93	2710	95	8	M8x70	41	2,52
06950065	65	105	85	93	2930	90	8	M8x70	41	2,69
06950070	70	115	100	110	3770	90	6	M10x80	83	3,94

ORDERING EXAMPLE:

The following will be ordered with a shaft having Ød 40 with a torque value less than or equal 900 Nm:

RCK 95 - 40 x 75

Part Number 06950040

CAD drawings available on our site
www.chiaravalli.com

3D simulation available on the website.



Quantity, availability and prices
on B2B Chiaravalli



GIFLEX[®]

FLEXIBLE COUPLINGS

SERIES GE-T	page 2
SERIES GE-T SG	16
SERIES GF	22
SERIES GFA	26
SERIES GFAS	34
SERIES FBX	40

TORQUE LIMITERS

TORQUE LIMITERS	46
TORQUE LIMITERS WITH CHAIN COUPLING LCG	51
CHAIN COUPLING WITH KC COVER	52



GIFLEX® GE-T COUPLINGS with FLEXIBLE SPIDER

SERIES GE-T

GE-T COUPLING STANDARD



GE-T COUPLING ALUMINIUM



GE-T COUPLING TAPER LOCK®



GE-T COUPLING SG



HUB A



HUB B

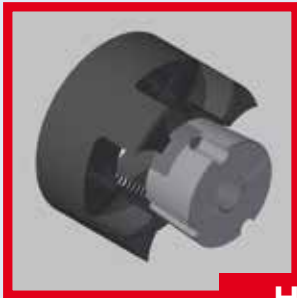

HUB I

internal bushes



HUB E

external bushes



YELLOW POLYURETHANE SPIDER



RED ELASTOMER SPIDER



BLACK ELASTOMER SPIDER



INTRODUCTION

Flexible torsion couplings, which are connecting devices between rotating shafts, are designed to ensure shock-free torque transmission and to compensate minor alignment deviations in operation between the shafts in industrial use.

The GE-T range of flexible couplings ensures this level of performance and also provides excellent quality thanks to the machining accuracy and the choice of materials.

The general level of reliability provided by the GE-T couplings results in a long life operation.



GENERAL

The GE-T range of flexible couplings represents torsionally flexible mechanical couplings capable of transmitting a twisting moment proportional to the flexible yield of the intermediate component. The couplings must be capable of effectively absorbing possible torsional vibrations due to the load or self-induced, to attenuate impacts and torque peaks during the start-up phase and to compensate minor angular and parallel misalignments between the shafts, however ensuring an acceptable useful working life.

These features and more in general the performance required from the coupling depend almost exclusively on the quality intermediate component.

The choice of the material used to manufacture the coupling is therefore fundamental. The curve that expresses the flexible characteristic of the intermediate component must have a progressive trend (yielding at low torque values and remaining rigid at higher torque values) to ensure operation without jerks at start-up and with a limited torsional yield at steady state conditions.

It is essential for the intermediate component to have a certain flexible hysteresis, proportional to the required absorbing effect that ensures the coupling can efficiently absorb possible torsional oscillations.

Furthermore, the useful working life of the coupling depends on the flexible yield of the material comprising the intermediary component. The physical characteristics has described above are frequently in contrast with each other and compared with other basic mechanical and technological parameters. The performance of the intermediary component therefore cannot be adapted to the variety of operating conditions when only one type of material is used and therefore the materials adopted for the flexible ring gear must be differentiated.

A selected thermoplastic elastomer is selected to meet medium level needs in the basic execution. This refers to an elastomer with medium rigidity, characterised by an optimum internal dampening effect, resistant to ageing, to fatigue, to abrasion, as well as hydrolysis and to the principle chemical agents with special reference to oils and ozone. Operating temperatures lying between -40 °C and + 125 °C with brief peaks of up to 150 °C are permitted in the case of couplings in the base execution. Alternative mixes capable of meeting every practical need have been designed and are available on request for use in extremely demanding operating conditions, or for needs that exceed average requirements.

OPERATING AND ASSEMBLY CONDITIONS

Operation of the flexible torsion couplings, such as the GE-T type or similar couplings is characterized by a proportional feature between the twisting torque and the torsion angle and by the ability to compensate limited angular and radial misalignments.

Key features of equal importance, but which are more difficult to interpret are represented by the absorbing factor and natural frequency or resonance.

To qualify its couplings, Chiaravalli Trasmissioni SpA declares permitted twisting torque values correlated to well defined torsion angle values, which has the limiting value of 5 ° C corresponding to the maximum torque value. This provides a valid guide for the progressive characteristic of the flexible curve. The maximum permitted values are shown in the case of the angular and radial misalignments, with the warning that these refer to extreme values that cannot be added together (only angular compensation or only radial compensation) and apply to standard operating conditions characterised by the following: operating torque not exceeding the nominal torque, a rotating speed of less than 1,450 r.p.m and coupling temperature not exceeding 40° C.

The maximum rotating speed expressed in r.p.m that corresponds to maximum peripheral speed of 30 m/sec. is indicated for each coupling of the GE-T range.

This speed can be achieved with a sufficient safety margin compared to the danger of failure due to centrifugal force stress thanks to the characteristics of the material used.

Class G 2.5 dynamic balancing in compliance with ISO 1940 is recommended despite the fact that the half-couplings are fully machined on both external surfaces, if the actual operating speed exceeds 2.800 r.p.m



COUPLING SELECTION AND SIZING CRITERION

Couplings are sized on the basis of the physical laws of mechanics and the resistance of the materials and also complies on the provisions established in the DIN 740 standards. the coupling is selected on the basis of the criterion, which establishes that the maximum permitted stress is never exceeded even in the most demanding operating conditions. It follows that the nominal torque declared for the coupling must be compared with a reference torque that takes into account the overloads due to the way the load is exerted and the operating conditions. The reference torque is obtained by multiplying the operating torque by a series of multiplying factors depending on the nature of the load or on the ambient temperature conditions.

LOAD DUE TO NOMINAL TORQUE

The permitted nominal coupling torque TKN must apply for any operating temperature value equal to or greater than the driven side operating torque TLN.

$$TKn = 9549 \frac{(PLn) [Nm]}{nLn}$$

The following condition must be satisfied, where St represents the temperature factor, to take into account overloads due to the operating temperature for the coupling.

$$TKn > TLN * St$$

START - UP LOAD

The drive motor delivers a drive torque during the start-up transient period which is a multiple of the nominal torque and depends on the way the masses are distributed. A similar situation occurs in the braking phase therefore, this two phases are characterised by torque impacts that have an intensivity which depends on the distribution of the masses on the drive side MA and on the driven side ML, as well as the frequency of the number of start – ups on which the start – up factor Sz depends. The static torques for the drive side and the driven side are expressed by the following relationships:

- drive side $TS = TAS * MA * SA$

- driven side $TS = TLS * ML * SL$

MA and ML are assumed to be equal to 1, to first approximation, and if the distribution of the masses is unknown. The SA factor can be assumed as being equal to the relationship between the start – up torque and the nominal torque in the case of drives based on an electric motor.

LOAD CAUSED BY TORQUE IMPACTS

The permitted nominal coupling torque TKN max must be equal to or greater than the start-up torque increased by the temperature factor and by St and by the start-up factor Sz for any operating temperature value.

$$TKn_{max} > TS * St * Sz$$

Consult the CHIARAVALLI Trasmissioni Technical Department for operating conditions that foresee periodic variation or torque inversions, as well as alternate torsional stresses.

SYMBOLS

- Tk n** = coupling maximum torque (Nm)
- Tk max** = coupling maximum torque (Nm)
- Tk w** = torque with coupling inversion (Nm)
- TLN** = driven side operating torque (Nm)
- TLs** = driven side static torque (Nm)
- TAs** = motor side static torque (Nm)
- Ts** = plant static torque (Nm)
- PLn** = driven side operating power (Nm)
- nLn** = driven side rotating speed (r.p.m)
- St** = temperature factor
- JA** = inertia moment drive site
- JL** = exit side
- SA** = motor side impact factor
- SL** = driven side impact factor
- Sz** = start-up factor

MA = control side mass factor $\frac{JL}{JA + JL}$

ML = driven side mass factor $\frac{JA}{JA + JL}$

INDICATIVE VALUES FOR ADJUSTMENT FACTORS:

Name	Symbol	Definition				
		Temperature factor	St.	1	1	1,4
Temperature factor	St.	C°	-30°	+40°	+80°	+120°
			+30°			
		Start-up factor	Sz.	Number of start-ups per hour		
Start-up factor	Sz.	Start-up/hr	100	200	400	800
		Sz.	1	1,2	1,4	1,6
Impact factor	SA/SL					SA/SL
		minor start-up impacts				1,5
		medium start-up impacts				1,8
		major start-up impacts				2,2

SERVICE FACTORS:

Load condition	Operating conditins	Type of Drive	
		Electric motor	Diesel engine
UNIFORM	Regular operation without impacts or overloads	1,25	1,50
LIGHT	Regular operations with minor and infrequent impacts and overloads	1,50	2,00
MEDIUM	Irregular operation with medium overloads for a short duration and frequent but moderate impacts	2,00	2,50
HEAVY	Markedly irregular operation with very frequent impacts and overloads and of major intensity	2,50	3,00

CHIARAVALLI GROUP BRAND GIFLEX®

AXIS MISALIGNMENTS COMPENSATED WITH COUPLING GE-T



TECHNICAL DATA

Spider for GE-T	
Employment temperature	
- Black	-40° +140°
- Yellow	-40° +90°
- Red	-30° +90°
- Green	-30° +110°

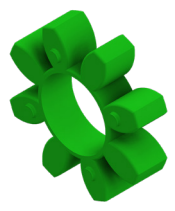

BLACK SPIDER 92-94Sh A THERMOPLASTIC YELLOW SPIDER 92-94Sh A POLYURETHAN RED SPIDER 96-98 Sh A POLYURETHAN GREEN SPIDER 64 Sh D POLYURETHAN

TECHNICAL DATA

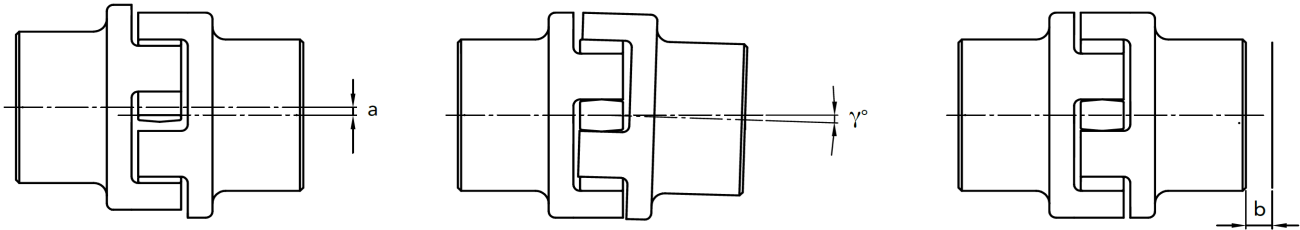

TECHNICAL DATA

SPIDER TYPE	MAX R.p.M.	SPIDER	COLOR	TORSION ANGLE		TORQUES (Nm)			Torsional rigidity (NMrad)				displacement								
				Tk n	tk MAX	Norm.	Max	with invers.	1.0	0.75	0.5	0.25	axial	radial	angular						
																TkN	Tk MAX	Tk w	Tk n	Tk n	Tk n
GE-T 19-24	1400	92/94 Sh a	BLACK	3°	5°	10	20	2,6	1280	1050	800	470	1,2	0,2	1,2°						
		92/94 Sh a	YELLOW			17	34	4,4	2920	2390	1810	1070									
		96/98 Sh a	RED																		
		64 Sh D	GREEN																		
92/94 Sh a	BLACK	35	70										9	4860	3980	3010	1790				
92/94 Sh a	YELLOW																				
96/98 Sh a	RED																				
GE-T 24-32	10600	64 Sh D	GREEN			60	120	16	9930	8140	6160	3650	1,4	0,2	0,9°						
		92/94 Sh a	BLACK																		
		92/94 Sh a	YELLOW																		
GE-T 28-38	8500	64 Sh D	GREEN			3°	5°	75	150	19,5	15110	12390	9370	5950	1,5	0,25	0,9°				
		92/94 Sh a	BLACK																		
		92/94 Sh a	YELLOW																		
		96/98 Sh a	RED																		
GE-T 38-45	7100	64 Sh D	GREEN					3°	5°	160	320	42	26770	21950	16600	9840	1,8	0,28	1,0°		
		92/94 Sh a	BLACK																		
		92/94 Sh a	YELLOW																		
		96/98 Sh a	RED																		
GE-T 42-55	6000	64 Sh D	GREEN	3°	5°					325	650	85	48570	39830	30110	17850	2,0	0,32	1,0°		
		92/94 Sh a	BLACK																		
		92/94 Sh a	YELLOW																		
		96/98 Sh a	RED																		
GE-T 48-60	5600	64 Sh D	GREEN							3°	5°	405	810	105	70150	57520	43490	25780	2,1	0,36	1,1°
		92/94 Sh a	BLACK																		
		92/94 Sh a	YELLOW																		
		96/98 Sh a	RED																		
GE-T 55-70	4750	64 Sh D	GREEN			3°	5°					525	1050	137	65290	53540	40480	24000	2,2	0,38	1,1°
		92/94 Sh a	BLACK																		
		92/94 Sh a	YELLOW																		
		96/98 Sh a	RED																		
GE-T 65-75	4250	64 Sh D	GREEN					3°	5°			625	1250	163	94970	77880	58880	34900	2,6	0,42	1,2°
		92/94 Sh a	BLACK																		
		92/94 Sh a	YELLOW																		
		96/98 Sh a	RED																		
GE-T 75-90	3550	64 Sh D	GREEN	3°	5°							940	1880	166	129510	106200	80300	47600	3,0	0,48	1,2°
		92/94 Sh a	BLACK																		
		92/94 Sh a	YELLOW																		
		96/98 Sh a	RED																		
GE-T 90-100	2800	64 Sh D	GREEN							3°	5°	1175	2350	305	151090	123900	93680	55530	3,4	0,5	1,2°
		92/94 Sh a	BLACK																		
		92/94 Sh a	YELLOW																		
		96/98 Sh a	RED																		
		64 Sh D	GREEN									3600	7200	936	312200	256000	193560	114730			
												4500	9000	1170	674520	553110	418200	247890			

with radial speed more than v=30m/s dynamic balancing is needed

EXAMPLE SPIDER CODE: 0200 24 14 → 010 BLACK
 012 YELLOW
 013 GREEN
 014 RED

↓ ↓
 TYPE SPIDER GE-T



CHIARAVALLI GROUP BRAND GIFLEX®

GE-T SERIES WITH ELASTIC SPIDER - ACCURATE DESIGN

TECHNICAL DATA

CAST IRON GG 25

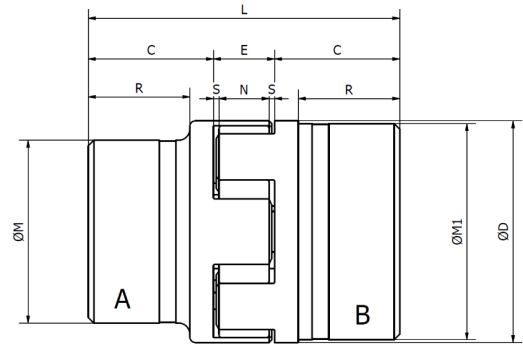
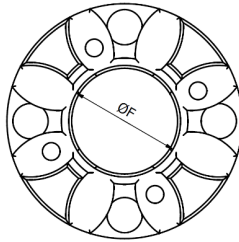

COUPLING TYPE	Ø BORE		Ø MAX BORE ALLOWED		DIMENSIONS											
					A-B										BL	
					A max	B/BL max	C	ØD	E	ØG	ØM	ØM1	N	R	S	L
GE-T 19A-24B*	-	-	19	24	25	40	16	18	30	40	12	19	2	66	37	31
GE-T 24A-32B	-	-	24	32	30	55	18	27	40	55	14	24	2	78	50	44
GE-T 28A-38B	-	-	28	38	35	65	20	30	48	65	15	27,5	2,5	90	60	52,5
GE-T 38A-45B	-	-	38	45	45	80	24	38	66	78	18	36,5	3	114	70	61,5
GE-T 42A-55B	-	-	42	55	50	95	26	46	75	94	20	40	3	126	75	65
GE-T 48A-60B	-	-	48	60	56	105	28	51	85	104	21	45	3,5	140	80	69
GE-T 55A-70B	-	-	55	70	65	120	30	60	98	118	22	52	4	160	90	88
GE-T 65A-75B	-	-	65	75	75	135	35	68	115	134	26	61	4,5	185	100	86
GE-T 75A-90B	-	-	75	90	85	160	40	80	135	158	30	69	5	210	110	97
GE-T 90A-100B	38	38	90	100	100	200	45	100	160	180	34	81	5,5	245	125	106

COUPLING TYPE	WEIGHT Kg				J Kg cm ² mozzi
	SPIDER elastico	HUB A	HUB B	HUB BL	
GE-T 19A-24B*	0,004	0,18	0,25		0,8
GE-T 24A-32B	0,014	0,36	0,55		3
GE-T 28A-38B	0,025	0,6	0,85		7
GE-T 38A-45B	0,042	1,35	1,65		20
GE-T 42A-55B	0,066	2	2,3		50
GE-T 48A-60B	0,088	2,75	3,1		80
GE-T 55A-70B	0,116	4,2	4,5		160
GE-T 65A-75B	0,172	6,5	6,8		310
GE-T 75A-90B	0,325	10	10,8		680
GE-T 90A-100B	0,44	14	15,8		1590

EXAMPLE HUB CODE:

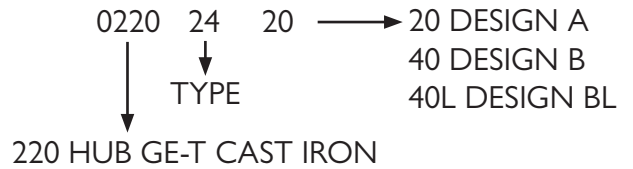

J Inertia moment hub A+B with max bore allowed

MAT. C45 EN 10083

MAT CAST IRON G20/25 EN 1561

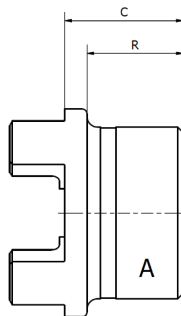

DESIGN A

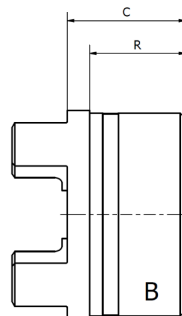

DESIGN B

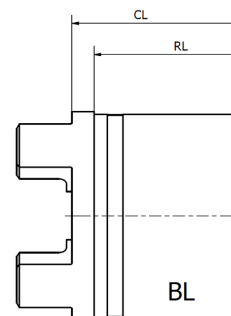

DESIGN BL



ALUMINIUM ALLOY

INTERPRETATION CODES

EXAMPLE

GE-T 19A-24B/AI = HUB A + HUB B

GE-T 19A-19A/AI = 2 hubs A

GE-T 24B-24B/AI = 2 hubs B

The characteristic size of the coupling is defined by the maximum diameter bore.

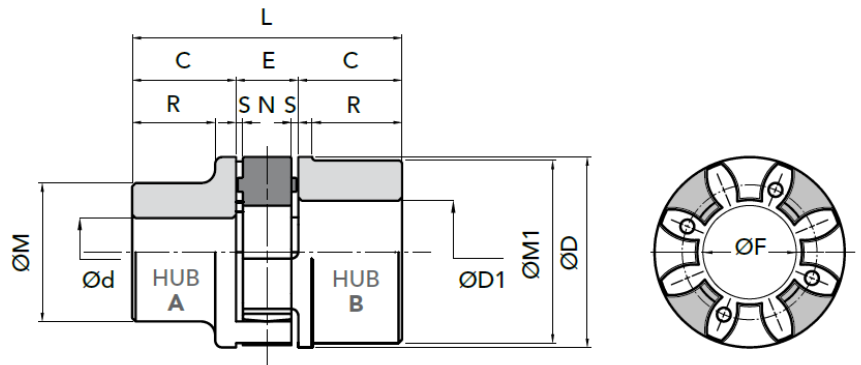

PART NUMBERS

COUPLING TYPE	PART NUMBER	PART NUMBER
	HUB A	HUB B
GE-T 19A-24B/AI	02301920	02301940
GE-T 24A-32B/AI	02302420	02302440
GE-T 28A-38B/AI	02302820	02302840
GE-T 38A-45B/AI	02303820	02303840

MEASUREMENTS - WEIGHTS

COUPLING TYPE	Ø pilot bore		Ø finished bore		measurement in mm normal range										Weight Kg			J Kg cm ² hubs A+B
	A	B	Ød max	ØD1 max	C	ØD	E	ØF	ØM	ØM1	N	R	S	L	spider	HUB A	HUB B	
																A	B	
GE-T 19A-24B/AI	6	10	19	24	25	40	16	18	30	40	12	19	2	66	0,005	0,07	0,08	0,4
GE-T 24A-32B/AI	8	14	24	32	30	55	18	27	40	55	14	24	2	78	0,014	0,13	0,18	1
GE-T 28A-38B/AI	10	16	28	38	35	65	20	30	48	65	15	27,5	2,5	90	0,025	0,22	0,3	3
GE-T 38A-45B/AI	12	20	38	45	45	80	24	38	66	78	18	36,5	3	114	0,042	0,48	0,55	8

J inertia torque HUB A+B with bore max Ø



CHIARAVALLI GROUP BRAND GIFLEX®

GE-T SERIES WITH ELASTIC SPIDER - ACCURATE DESIGN

CAST-IRON GG25

with **TAPER BUSH® LOCK**

INTERPRETATION CODES

EXAMPLE

GE-T 28I-38E = HUB I + HUB E

GE-T 28E-38I = HUB E + HUB I

GE-T 28I-28I = 2 hubs I

GE-T 38E-38E = 2 hubs E

Insertion bush:

HUB **I** with internal assembled bush

HUB **E** with external assembled bush

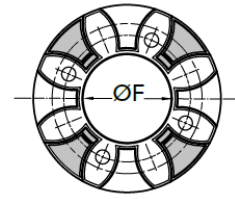
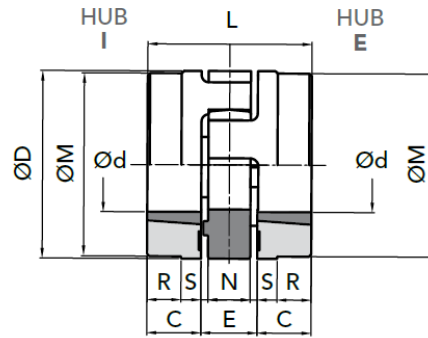

PART NUMBERS FOR COMPLETE COUPLINGS

COUPLING TYPE	PART NUMBER	PART NUMBER
	HUB I	HUB E
GE-T 28-38 TL	03202841	03202840
GE-T 38-45 TL	03203841	03203840
GE-T 42-55 TL	03204241	03204240
GE-T 48-60 TL	03204841	03204840
GE-T 55-70 TL	03205541	03205540
GE-T 75-90 TL	03207541	03207540

MEASUREMENTS - WEIGHTS

COUPLING TYPE	Ø pilot bore	finished bore		measurement in mm normal range									Weight Kg		J Kg cm ² hubs
		Ød max	ØD1 max	C	ØD	E	ØF	ØM	N	S	L	R	spider	HUB bore max	
GE-T 28-38 TL	1108	14	25	23	65	20	30	65	15	2,5	66	-	0,025	0,50	7
GE-T 38-45 TL	1108	14	25	23	80	24	38	78	18	3	70	15	0,042	0,88	26
GE-T 42-55 TL	1610	14	42	26	95	26	46	94	20	3	78	16	0,066	1,40	36
GE-T 48-60 TL	1615	19	40	39	105	28	51	104	21	3,5	106	28	0,088	2,33	78
GE-T 55-70 TL	2012	19	50	33	120	30	60	118	22	4	96	20	0,116	2,42	120
GE-T 75-90 TL	2517	19	65	57	160	40	80	158	30	5	154	41	0,325	6,80	630

CHIARAVALLI GROUP BRAND GIFLEX®

GE-T SG SERIES BACKLASH-FREE TORSIONAL COUPLING



INTRODUCTION

The aluminium flexible couplings GE-T SG are made of three pre-tensioned elements in backlash-free execution. They are meant for the coupling mounting and they are designed to fit low torque working units and industrial processing, where they must satisfy certain requirements.

Thanks to their limited dimensions and their easy mounting, they can operate in little space and any project can take big advantages of it.

FEATURES

The buckle tightening guarantees a quick and sure fixing without extension between shaft and hub. It is however important to keep the screw tightening torque (MS) shown in the table. Besides testing the size of the coupling given in the table, it is suggested to test the maximum torque of buckle to diameter (F).

The elastomeric element, that has a star shape, is set into the hubs' hollow seats with a light pre-tensioning, ensuring the needed transmission torque backlash-free execution.

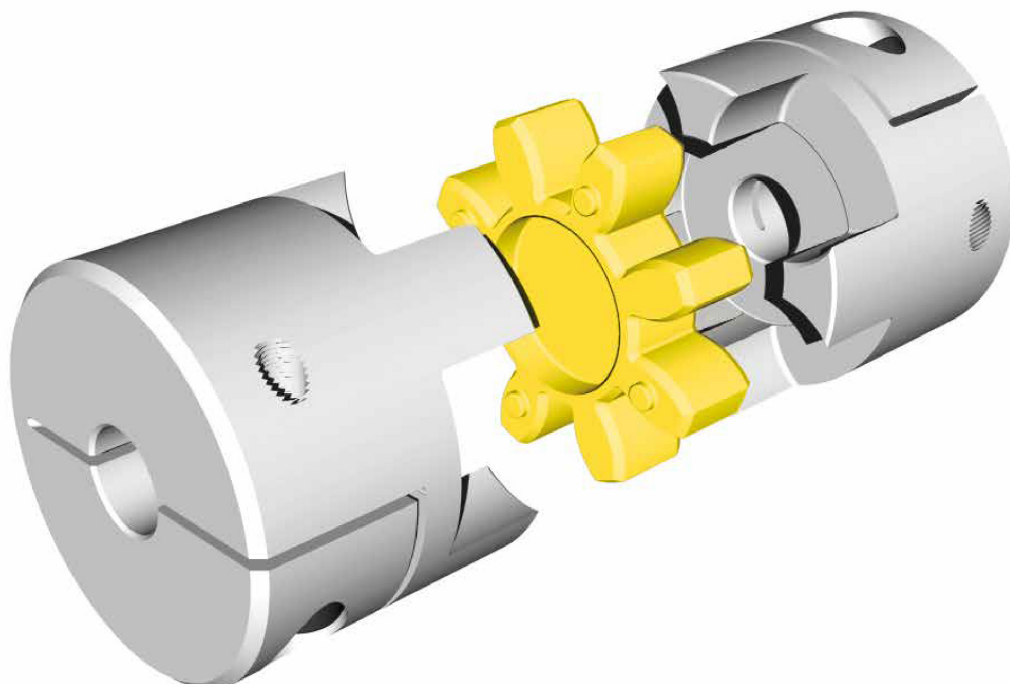
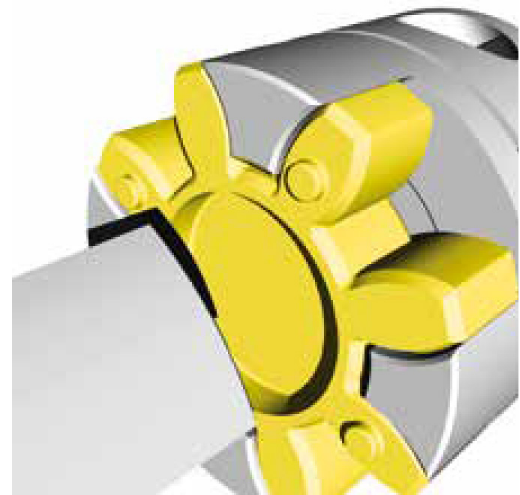

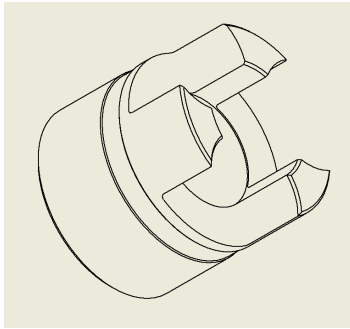

DESIGN A

Solid hub size 9 and 14 for 4-spikes elastomer, size 19 for 6-spikes elastomer

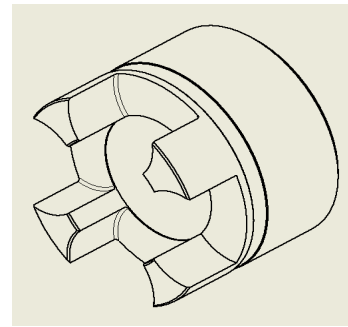

DESIGN B

Solid hub from size 24 to 38 for 8-spikes elastomer

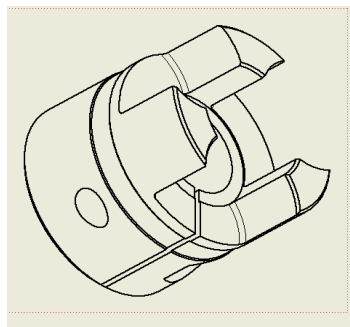

DESIGN C

With single-cut clamp from size 9 to size 19, torques suitable according to hole-diameter.
Also available with the compact version from size 9 to size 38

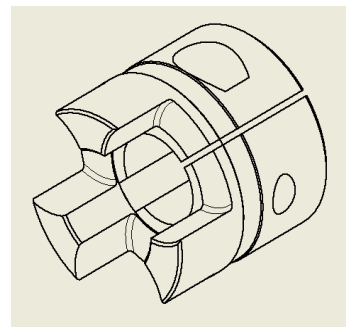

DESIGN CK

With single-cut clamp and keyway acc.to DIN 6885 - JS9 , from size 14 to size 19. Also available with the compact version from size 9 to size 38

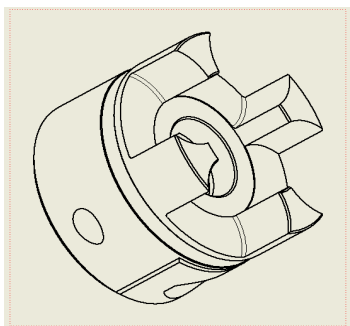

DESIGN D

With double-cut clamp from size 24 to size 38, torques suitable according to hole-diameter

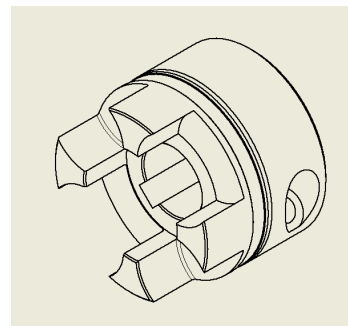

DESIGN DK

With double-cut clamp and keyway acc.to DIN 6885 - JS9 , from size 24 to size 38

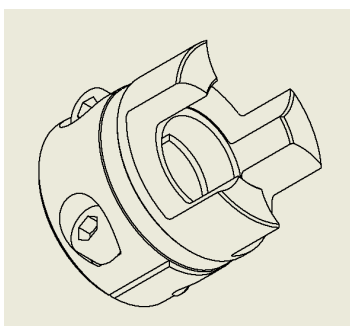

DESIGN H

With 2x screws fixing clamp for radial mounting, torques suitable according to hole-diameter. Available from size 14 to size 42

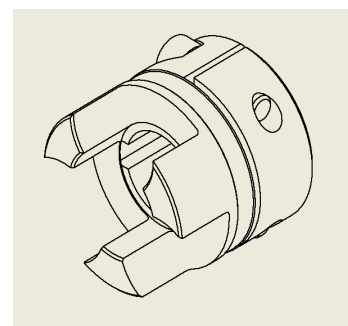

DESIGN HK

With 2x Screws fixing clamp for radial mounting and keyway acc.to DIN 6885-JS9. Available from size 14 to size 42

CHIARAVALLI GROUP BRAND GIFLEX®

GE-T SERIES WITH ELASTIC ELEMENT – TRANSFERABLE PAIRS

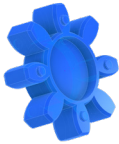

BLUE 80 Sh A
POLYURETHAN



YELLOW 92/94 Sh A
POLYURETHAN

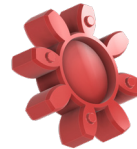

RED 96/98 Sh A
POLYURETHAN

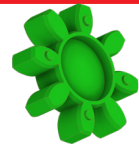

GREEN 64 Sh D
POLYURETHAN

TECHNICAL DATA

COUPLING TYPE	HARDNESS WITH SPIDER	MAX speed for type				Nm		Stiffness			Max inertia moment Kgm ² x 10 ⁻⁶
		Design C	Design D	Design H	max	Tk n couple	Tk max couple	tors. static Nm/rad	tors. dynamic Nm/rad	radial Nm	
GE-T 9 SG	80 Sh A	19000			28000	1,8	3,6	17,02	52	125	0,57
	92/94 Sh A					3	6	31,5	95	262	
	96/98 Sh A					5	10	51,5	150	518	
GE-T 14 SG	80 Sh A	12700		12700	19000	4	8	60,2	180	153	3,25
	92/94 Sh A					7,5	15	114,6	344	336	
	96/98 Sh A					12,5	25	172	513	604	
	64 Sh D					16	32	238	702	856	
GE-T 19-24 SG	80 Sh A	9550		9550	14000	4,9	9,8	343,8	1030	740	21,9
	92/94 Sh A					10	20	573	1720	1260	
	96/98 Sh A					17	34	859	2580	2210	
	64 Sh D					21	42	2450	3820	2970	
GE-T 24-28 SG	80 Sh A		6950	6950	10600	17	34	850	1385	840	58,3
	92/94 Sh A					35	70	2280	4296	1900	
	96/98 Sh A					60	120	3700	8125	2940	
	64 Sh D					75	150	5000	11000	3700	
GE-T 28-38 SG	80 Sh A		5850	5850	8500	46	92	1360	2345	990	216,8
	92/94 Sh A					95	190	3820	7260	2100	
	96/98 Sh A					160	320	4190	10315	3680	
	64 Sh D					200	400	10010	20035	4400	
GE-T 38-45 SG	80 Sh A		4750	4750	7100	95	190	3000	6100	1400	445,2
	92/94 Sh A					190	380	4589	13752	2900	
	96/98 Sh A					325	650	7160	21485	5040	
	64 Sh D					405	810	25600	40250	6445	
GE-T 42 SG	80 Sh A		4000	4000	6000	46	92			990	2802
	92/94 Sh A					95	190	2292	6879	2100	
	96/98 Sh A					160	320	3438	10315	3680	
	64 Sh D									4400	

with radial speed more than v=30m/s dynamic balancing is needed

Axial Displacement

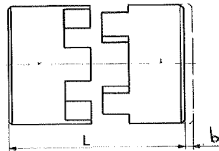

Radial Displacement

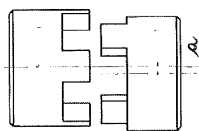

Angular Displacement

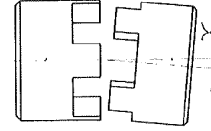

COUPLING TYPE	Displacement			
	spider GE-T SG	AXIAL b (mm)	RADIAL a (mm)	ANGULAR U(degree)
GE-T 9 SG	80 Sh A	+0,9	0,19	1,1°
	92/94 Sh A		0,13	1,0°
	96/98 Sh A	-0,9	0,08	0,9°
	64 Sh D		0,05	0,8°
GE-T 14 SG	80 Sh A	+1,0	0,21	1,1°
	92/94 Sh A		0,15	1,0°
	96/98 Sh A	-0,5	0,09	0,9°
	64 Sh D		0,08	0,8°
GE-T 19-24 SG	80 Sh A	+1,2	0,15	1,1°
	92/94 Sh A		0,10	1,0°
	96/98 Sh A	-0,5	0,08	0,9°
	64 Sh D		0,04	0,8°
GE-T 24-28 SG	80 Sh A	+1,4	0,14	1,0°
	92/94 Sh A		0,10	0,9°
	96/98 Sh A	-0,5	0,07	0,8°
	64 Sh D		0,04	0,7°
GE-T 28-38 SG	80 Sh A	+1,5	0,15	1,0°
	92/94 Sh A		0,11	0,9°
	96/98 Sh A	-0,5	0,08	0,8°
	64 Sh D		0,05	0,7°
GE-T 38-45 SG	80 Sh A	+1,8	0,17	1,0°
	92/94 Sh A		0,12	0,9°
	96/98 Sh A	-0,7	0,09	0,8°
	64 Sh D		0,06	0,7°
GE-T 42 SG	80 Sh A	+2,0	0,19	1,0°
	92/94 Sh A		0,14	0,9°
	96/98 Sh A	-1,0	0,10	0,8°
	64 Sh D		0,07	0,7°

EXAMPLE SPIDER CODE:

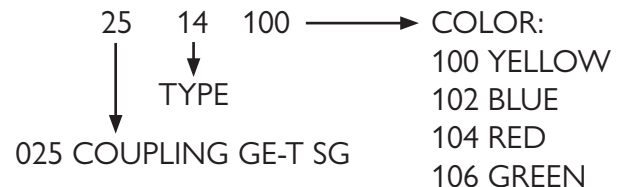



CHIARAVALLI GROUP BRAND GIFLEX®

GE-T SG SERIES BACKLASH-FREE TORSIONAL COUPLING

TECHNICAL DATA

HUB DESIGN A AND B - SOLID HUB
MAT ALUMINIUM

With spider
4 pointed

GE-T 09 SG
GE-T 14 SG

6 pointed
8 pointed

GE-T 19-24 SG
GE-T 24-28 SG
GE-T 28-38 SG
GE-T 38-45 SG

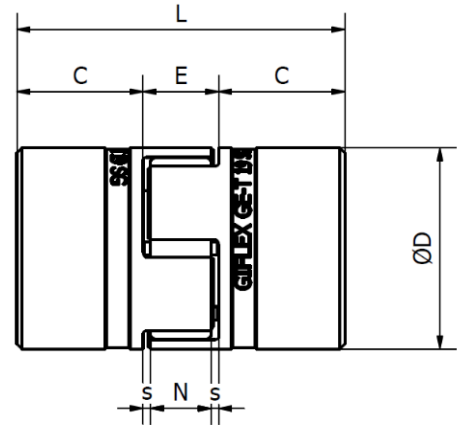
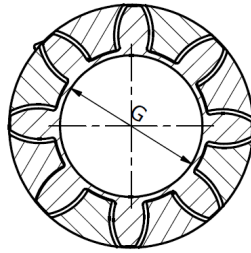

DIMENSIONS										
Coupling Type	achievable minimum bore Ø	achievable maximum bore Ø	Ø D	Ø G	L	C	E	N	S	Design
GE-T 09 SG	4	9	20	7,2	30	10	10	8	1	A
GE-T 14 SG	4	14	30	10,5	35	11	13	10	1,5	A
GE-T 19-24 SG	10	20	40	18	66	25	16	12	2	A
GE-T 24-28 SG	15	28	55	27	78	30	18	14	2	B
GE-T 28-38 SG	19	35	65	30	90	35	20	15	2,5	B
GE-T 38-45 SG	20	45	80	38	114	45	24	18	3	B

MAT: Aluminium 6082-T6 EN 573

EXAMPLE HUB CODE:

025 14 200 → 200 SOLID HUB
 ↓ TYPE
 025 COUPLING GE-T SG

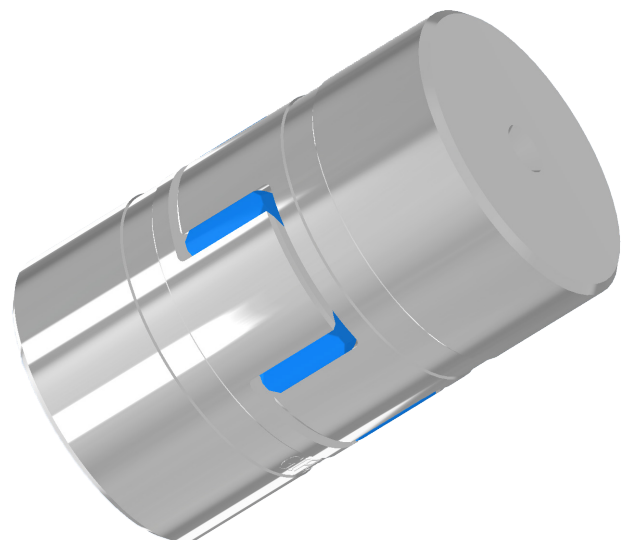

CHIARAVALLI GROUP BRAND GIFLEX® GE-T SG SERIES BACKLASH-FREE TORSIONAL COUPLING



TECHNICAL DATA

HUB DESIGN C WITH SINGLE CUT

With spider
4 pointed

GE-T 09 SG
GE-T 14 SG

6 pointed

GE-T 19-24 SG

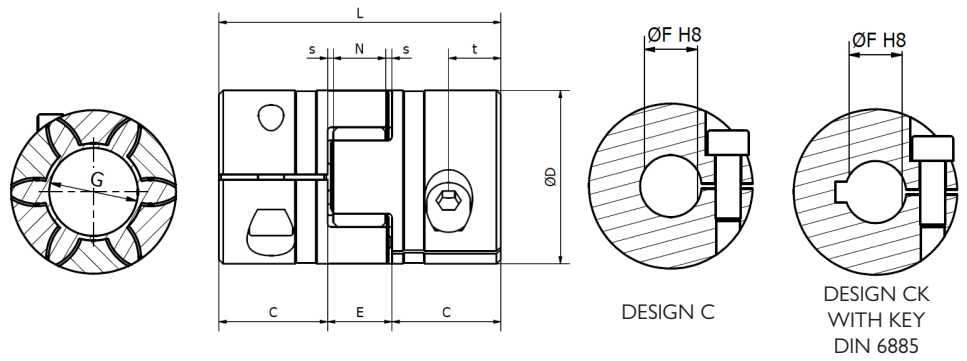

DIMENSIONS												
COUPLING TYPE	ØF H8 - friction torque for design C	Ø D	Ø G	L	C	E	N	s	f	Ms screw (Nm) clamping torque	t	
GE-T 09 SG	5 - 6 - 8 - 10	20	7,2	30	10	10	8	1	M2,5	0,75	5	
FRICITION TORQUE Nm	1,55 - 1,63 - 1,79 - 1,94											
GE-T 14 SG	5 - 6 - 8 - 10 - 12 - 14 - 15 - 16	30	10,5	35	11	13	10	1,5	M3	1,4	5	
FRICITION TORQUE Nm	3,32 - 3,43 - 3,67 - 3,91 - 4,14 - 4,38 - 4,5 - 4,6											
GE-T 19-24 SG	8 - 10 - 12 - 14 - 15 - 16 - 18 - 19 - 20	40	18	66	25	16	12	2	M6	11	12	
FRICITION TORQUE Nm	18 - 19 - 20 - 21 - 21,5 - 22 - 22,5 - 23 - 24											

EXAMPLE HUB CODE:

025 14 2 12 K → 200 SOLID HUB
 ↓ ↓ ↓ ↓ ↓
 TYPE MAT 2 - ALUMINIUM
 3 - STEEL C45
 025 COUPLING GE-T SG

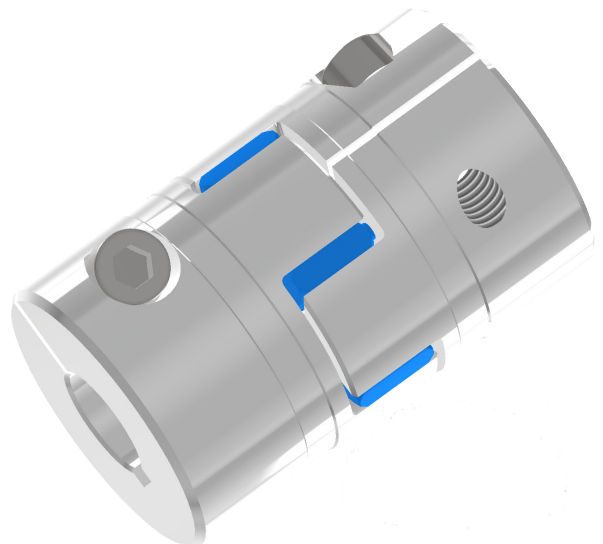

MAT: ALUMINIUM 6082 - T6 EN 573

MAT: STEEL C45 EN 10083



CHIARAVALLI GROUP BRAND GIFLEX®

GE-T SG SERIES BACKLASH-FREE TORSIONAL COUPLING

TECHNICAL DATA

HUB DESIGN D WITH DOUBLE CUT

with spider
8 pointed

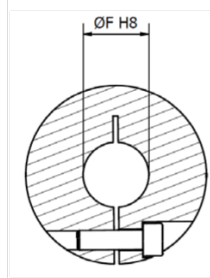
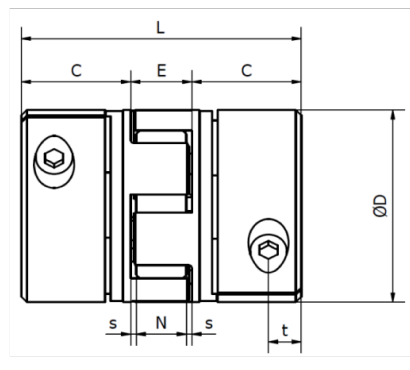
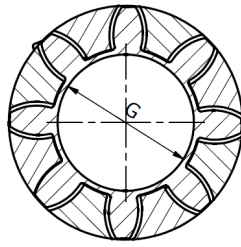

Design D

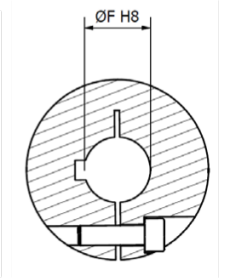

Design DK WITH KEY
DIN 6885

DIMENSIONS

COUPLING TYPE	ØF H8 - friction torque for design D	Ø D	Ø G	L	C	E	N	s	f	Ms screw (Nm) clamping torque	t
GE-T 24-28 SG	12 14 15 16 18 19 20 22 24 25 28	55	27	78	30	18	14	2	M6	11	14
FRICITION TORQUE Nm	25 - 26 - 27 - 27,5 - 28 - 28,5 - 29 - 30 - 31 - 32 - 33										
GE-T 28-38 SG	18 19 20 22 24 25 28 30 32 35	65	30	90	35	20	15	2,5	M8	25	15
FRICITION TORQUE Nm	60 - 61 - 62 - 63 - 65 - 66 - 69 - 71 - 73 - 75										
GE-T 38-45 SG	18 19 20 22 24 25 28 30 32 35 38 40	80	38	114	45	24	18	3	M8	25	20
FRICITION TORQUE Nm	69 - 70 - 71 - 73 - 74 - 78 - 78 - 80 - 81 - 84 - 87 - 88										

EXAMPLE HUB CODE:

025 24 2 20 K → WITH KEYWAY

→ Ø BORE

→ MAT 2 - ALUMINIUM
3 - STEEL C45

→ TYPE

025 COUPLING GE-T SG

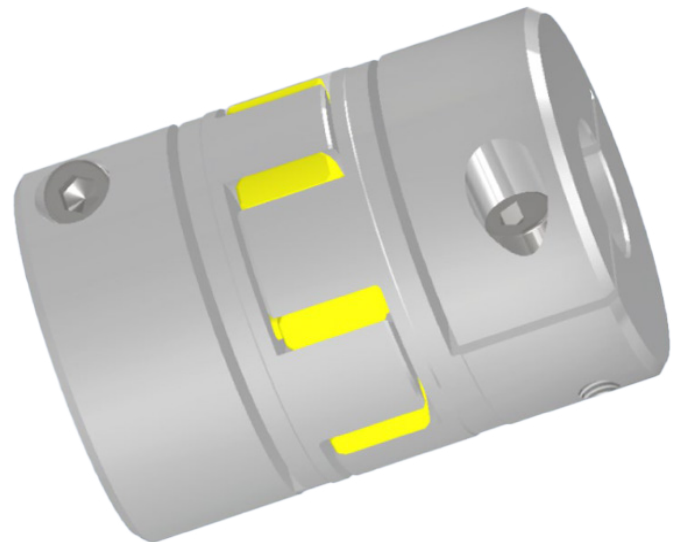

MAT: ALUMINIUM 6082 - T6 EN 573

MAT: STEEL C45 EN 10083

CHIARAVALLI GROUP BRAND GIFLEX®

GE-T SG SERIES BACKLASH-FREE TORSIONAL COUPLING



TECHNICAL DATA

HUB EXECUTION C COMPACT VERSION WITH SINGLE CUT

MAT ALUMINIUM

With spider
4 pointed

GE-T 09 SG
GE-T 14 SG

6 pointed
8 pointed

GE-T 19-24 SG
GE-T 24-28 SG
GE-T 28-38 SG
GE-T 38-45 SG

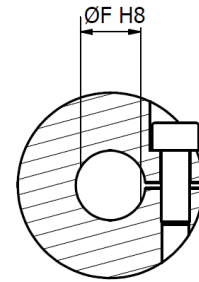
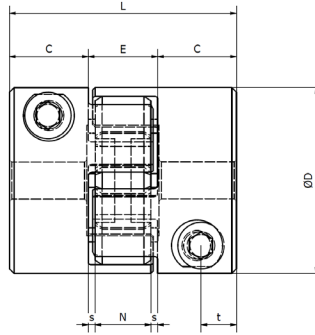
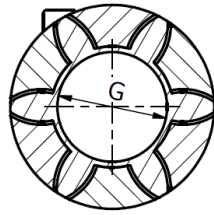

Design C

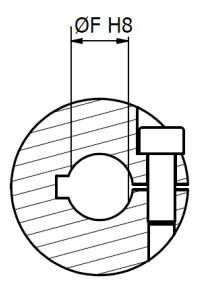

Design CK
with key
DIN 6885

DIMENSIONS

COUPLING TYPE	ØF H8 - friction torque Nm for design C	Ø D	Ø G	L	C	E	N	S	SCREW	Ms screw (Nm) clamping torque	t
GE-T 09 SG C	5 - 6 - 8 - 10	20	7,2	24	7	10	8	1	M2,5	0,75	3,5
FRICITION TORQUE Nm	2 2.1 2.3 2.5										
GE-T 14 SG C	5 - 6 - 8 - 10 - 12 - 14 - 15 - 16	30	10,5	32	10,0	13	10	1,5	M4	3,1	5
FRICITION TORQUE Nm	7.1 7.4 8 8.5 9.1 10.2 10.5 11										
GE-T 19-24 SG C	8 - 10 - 12 - 14 - 15 - 16 - 18 - 19 - 20	40	18	50	17	16	12	2	M6	11	8,5
FRICITION TORQUE Nm	24.3 25.7 27 28.4 29 29.7 33.1 31.7 32,4										
GE-T 24-28 SG C	12 - 14 - 15 - 16 - 18 - 19 - 20 - 22 - 24 - 25 - 28	55	27	54	18	18	14	2	M6	11	9
FRICITION TORQUE Nm	36 37 38 39 40 41 41 42 44 44 46										
GE-T 28-38 SG C	18 - 19 - 20 - 22 - 24 - 25 - 28 - 30 - 32 - 35	65	30	62	21	20	15	2,5	M8	25	10,5
FRICITION TORQUE Nm	83 84 85 88 90 91 95 98 100 104										
GE-T 38-45 SG C	18 - 19 - 20 - 22 - 24 - 25 - 28 - 30 - 32 - 35 - 38 - 40	80	38	76	26	24	18	3	M10	45	13
FRICITION TORQUE Nm	105 108 112 120 125 129 135 143 150 160 172 181										

EXAMPLE HUB CODE:

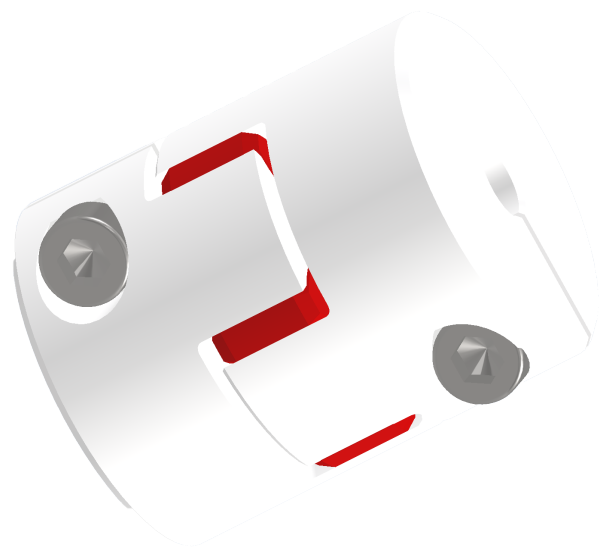
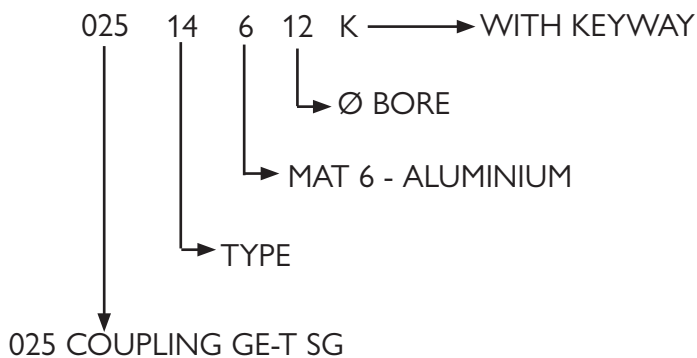

MAT: ALUMINIUM 6082 - T6 EN 573

MAT: ■ UPON REQUEST



CHIARAVALLI GROUP BRAND GIFLEX®

GE-T SG SERIES BACKLASH-FREE TORSIONAL COUPLING

TECHNICAL DATA

HUB DESIGN H WITH HALFSHELL CLAMP

With spider
4 pointed
6 pointed
8 pointed

- GE-T 14 SG**
- GE-T 19-24 SG**
- GE-T 24-28 SG**
- GE-T 28-38 SG**
- GE-T 38-45 SG**
- GE-T 42-55 SG**

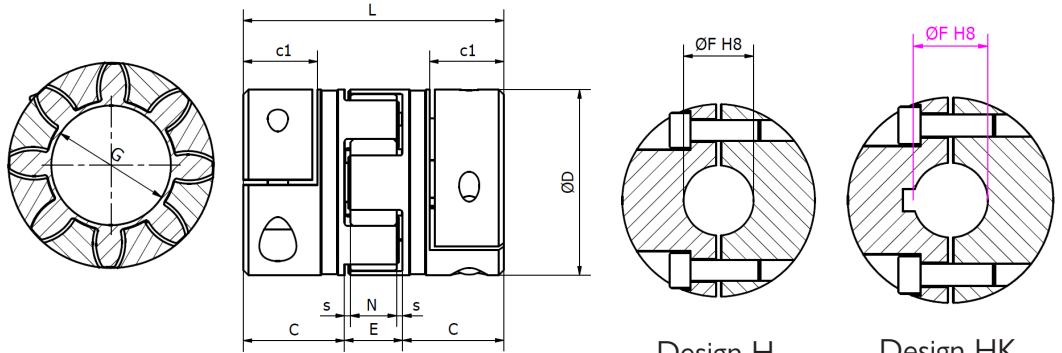

Design H

Design HK
with key
DIN 6885

DIMENSIONS

COUPLING TYPE	ØF H8 - friction torque Nm for design H	D	G	L	C	c1	E	N	s	SCREW	Ms screw (Nm) clamping torque
GE-T 14SG	5 - 6 - 8 - 10 - 12 - 14 - 15 - 16	30	10,5	50	18	13,3	13	10	1,5	M4	5
FRICITION TORQUE Nm	8 8.3 8.9 9.5 10.1 10.7 11 11,3										
GE-T 19-24SG	8 - 10 - 12 - 14 - 15 - 16 - 18 - 19 - 20	40	18	66	25	17,5	16	12	2	M6	10
FRICITION TORQUE Nm	17 21 24 30 32 34 38 40 42										
GE-T 24-28SG	12 - 14 - 15 - 16 - 18 - 19 - 20 - 22 - 24 - 25 - 28	55	27	78	30	20,5	18	14	2	M6	10
FRICITION TORQUE Nm	28 30 32 34 38 40 42 47 51 53 59										
GE-T 28-38SG	18 - 19 - 20 - 22 - 24 - 25 - 28 - 30 - 32 - 35	65	30	90	35	25	20	15	2,5	M8	25
FRICITION TORQUE Nm	70 74 78 88 93 97 109 117 124 136										
GE-T 38-45SG	18 - 19 - 20 - 22 - 24 - 25 - 28 - 30 - 32 - 35 - 38 - 40	80	38	114	45	33	24	18	3	M8	25
FRICITION TORQUE Nm	70 74 78 88 93 97 109 117 124 136 148 156										
GE-T 42-55SG	22 - 24 - 25 - 28 - 30 - 32 - 35 - 38 - 40 - 42 - 45 - 48 - 50	95	46	126	50	39	26	20	3	M10	45
FRICITION TORQUE Nm	136 149 155 174 188 198 217 235 248 260 279 297 310										

EXAMPLE HUB CODE:

025 24 2 20 K → WITH KEYWAY
 ↳ TYPE
 ↳ MAT 2 - ALUMINIUM
 ↳ 3 - STEEL C45
 ↳ Ø BORE

025 COUPLING GE-T SG

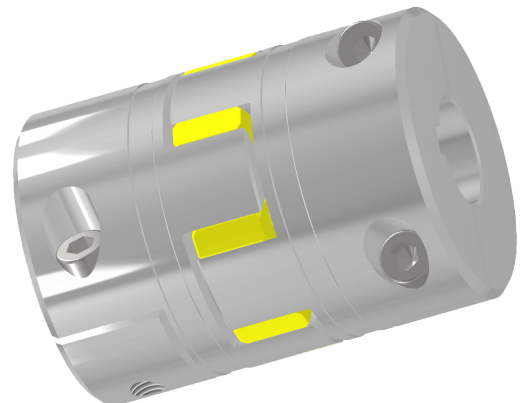
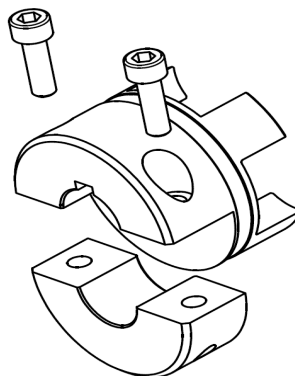

MAT: ALUMINIUM 6082 - T6 EN 573

MAT: STEEL C45 10083

MAT: ■ UPON REQUEST



TECHNICAL DATA

DESIGN B

One piece

DESIGN C

Two pieces

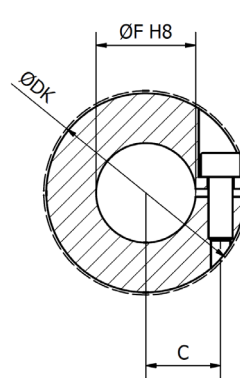
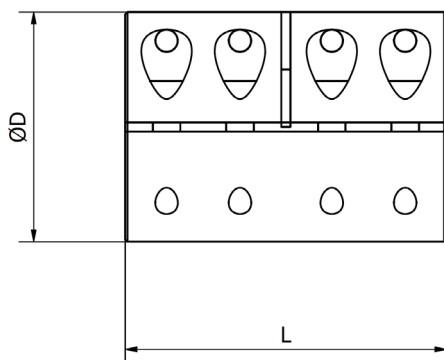

Design B

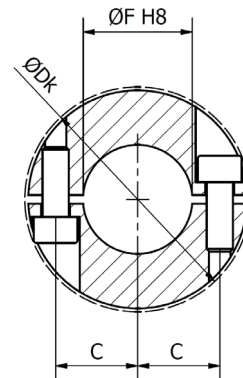

Design C

COUPLING TYPE	DIMENSIONS				
	Ø D	Ø DK	Ø F H8	L	C
JR001	32	33	10	45	10,5
JR002	40	-	15	50	13,5
JR003	45	47	20	65	16,25
JR004	50	52	25	70	18,75
JR005	55	57	30	75	21,25
JR006	65	70	35	85	25
JR007	70	74	40	90	27,5
JR008	80	83	45	10	31,25
JR009	90	95	50	110	35

MAT: STEEL C45 EN 10083

CH CODE	
DESIGN B	DESIGN C
RJ001B	RJ001C
RJ002B	RJ002C
RJ003B	RJ003C
RJ004B	RJ004C
RJ005B	RJ005C
RJ006B	RJ006C
RJ007B	RJ007C
RJ008B	RJ008C
RJ009B	RJ009C

COUPLING TYPE	TECHNICAL DATA						
	WEIGHT	FRICTION TORQUE N _m		MAX SPEED	SCREW 12.9		
	Kg	DESIGN B	DESIGN C	RPM	DESIGN B	DESIGN C	TIGHTENING TORQUE
RJ001	0,25	65	50	5500	n°4 x M4	n°8 x M4	4,9
RJ002	0,42	140	125	4200	n°4 x M5	n°8 x M5	9,7
RJ003	0,65	250	230	3800	n°4 x M6	n°8 x M6	17
RJ004	0,87	295	285	3500	n°4 x M6	n°8 x M6	17
RJ005	1,11	350	345	3200	n°4 x M6	n°8 x M6	17
RJ006	1,75	800	760	2700	n°4 x M8	n°8 x M8	41
RJ007	2,13	880	870	2500	n°4 x M8	n°8 x M8	41
RJ008	2,96	990	980	2200	n°4 x M8	n°8 x M8	41
RJ009	4,31	1420	1360	1900	n°4 x M10	n°8 x M10	83



GF COUPLINGS
with POLYAMIDE SLEEVE



PRESENTATION

The GIFLEX range of flexible toothed couplings are commercial couplings for general applications, which are however manufactured to a high quality standard and offer technical and performance features that are typical of industrial couplings. The specific application sector refers to power transmissions for the flexible connection of rotating parts, with the possibility of compensating radial and angular misalignments and absorbing axial slippage.

The performance is in line with this class of couplings, rendered more demanding and better suited to the needs of industrial requirements by the design criteria adopted and the precision with which the couplings are machined and systematically tested.

CONSTRUCTION

In structural terms, the flexible toothed couplings consist of two symmetrical steel hubs and a synthetic resin sleeve, which ensures the coupling and power transmission between the two hubs.

The two hubs are manufactured from low carbon content steel and have been subjected to anti-corrosion surface treatment and are each fitted with a toothed ring.

The hollow sleeve with internal toothing formed by injection moulding comprises a high molecular weight semi-crystalline technical polymer, guaranteed by certification at origin, thermally conditioned and charged with a solid lubricant that contributes to enhance the self-lubricating features typical of the polymer. The toothing of the two hubs has a progressive dual curvature, produced using a Numerically Controlled machine tool, which ensures the coupling provides optimum performance. This solution enables dynamic type angular and radial misalignments to be compensated **ALSO UNDER LOAD CONDITIONS**. The specific geometry of the tooth for a given transmitted twisting moment significantly reduces the surface pressure, thereby increasing the coupling's capacity to transmit the load and fatigue resistance.

The polymer's relative insensitivity to atmospheric humidity and its capacity to withstand temperatures between -20° and $+120^{\circ}$ with brief peaks of up to $+150^{\circ}$ enable the coupling to withstand demanding working conditions also in an aggressive environment.

CHARACTERISTICS

The couplings provide the following performance in practical applications:

- Reduced overall dimensions, weight and inertia moment;
- Constant velocity behaviour at speed;
- Silent operation and the ability to absorb impacts and vibrations flexibly;
- Withstand the most common aggressive chemical agents and moderate heat, max. temp. 80° ;
- Self-lubricating, electrically insulated and maintenance-free;
- Inexpensive, easily assembled and are suited to a variety of applications, also in demanding conditions.

TIPOLOGY of HUBS for SERIES GF



NORMAL HUB



LONG HUB

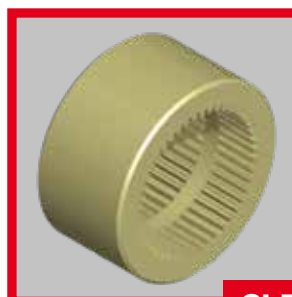

SLEEVE



COUPLING SELECTION

Torque based selection:
the coupling must be selected so that the max motor torque does not exceed the coupling's per-mitted peak twisting moment.

ASSEMBLY GUIDELINES

- Position the two semi-couplings on the shafts, taking care that the internal surfaces are in line with the shaft ends.
- Insert the sleeve on the two semi-couplings adjusting their distance (distance "G"), while the two shafts are aligned at the same time.
- Clamp the two parts to be coupled together in position.
- Check that the sleeve is free to move in an axial direction before the coupling is rotated.

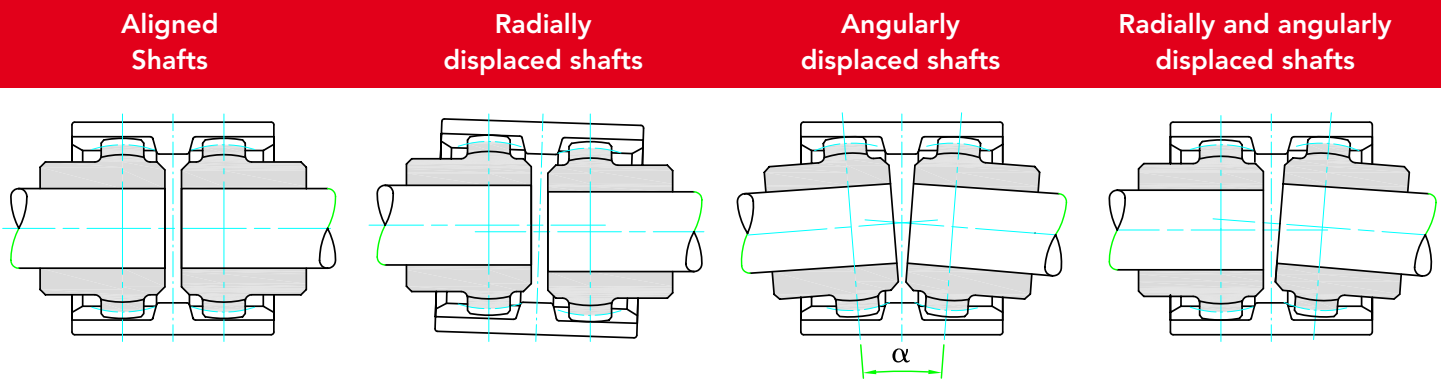

TECHNICAL DATA

COUPLING TYPE	Power factor Kw r.p.m.		Torque Nm		power transmitted in kw at r.p.m.								r.p.m. max	mass kg	J kg cm ²	Maximum misalignment for each hub		Axial displacement mm
	norm	max	norm	max	750		1000		1500		3000					Angular a	Radial mm	
GF 14	0,0011	0,0023	11,5	23	0,8	1,5	1,1	2,0	1,6	3,0	3,3	6,0	14.000	0,166	0,27	± 2°	0,7	± 1
GF 19	0,0019	0,0037	18,5	36,5	1,3	2,7	1,8	3,7	2,7	5,5	5,4	11,1	12.000	0,276	0,64	± 2°	0,8	± 1
GF 24	0,0023	0,0047	23	46	1,7	3,5	2,3	4,7	3,4	7,0	6,9	14,1	10.000	0,312	0,92	± 2°	0,8	± 1
GF 28	0,0053	0,0106	51,5	103,5	3,9	7,9	5,2	10,6	7,8	15,9	15,6	31,8	8.000	0,779	3,45	± 2°	1,0	± 1
GF 32	0,0071	0,0142	69	138	5,2	10,5	7,0	14,1	10,5	21,1	21,0	42,3	7.100	0,918	5,03	± 2°	1,0	± 1
GF 38	0,0090	0,0181	88	176	6,7	13,5	9,0	18,0	13,5	27,0	27,0	54,0	6.300	1,278	9,59	± 2°	0,9	± 1
GF 42	0,0113	0,0226	110	220	8,4	16,8	11,2	22,5	16,8	33,7	33,6	67,5	6.000	1,473	13,06	± 2°	0,9	± 1
GF 48	0,0158	0,0317	154	308	11,8	23,6	15,8	31,6	23,7	47,4	47,4	94,8	5.600	1,777	18,15	± 2°	0,9	± 1
GF 55	0,029	0,058	285	570	21,7	43,5	29,0	58,0	43,5	87,0	87,0	174,0	4.800	3,380	49,44	± 2°	1,2	± 1
GF 65	0,0432	0,0865	420	840	32,1	64,3	42,9	85,8	64,3	128,7	128,7	257,4	4.000	4,988	106,34	± 2°	1,3	± 1

J inertia moment HUB A+B
with bore Ø max

CAD drawings available on our site
www.chiaravalli.com

Quantity, availability and prices
on B2B Chiaravalli



POLYAMIDE SLEEVE

INTERPRETATION CODES

EXAMPLE

GF 14-NN with 2 normal hubs

GF 14-NL with 1 normal hubs
and 1 long hub

GF 14-LL with 2 long hubs

The characteristic size of the coupling is defined by the maximum diameter bore.

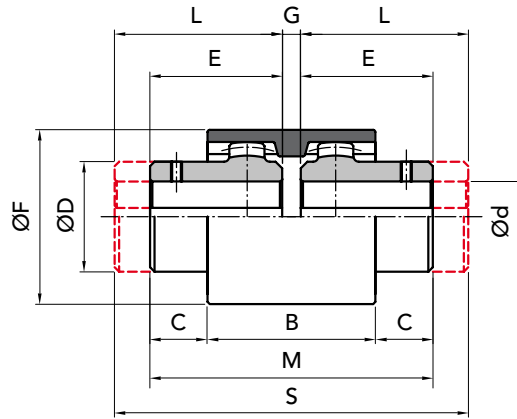

PART NUMBERS FOR COMPLETE COUPLING

PART NUMBERS FOR SIMPLE COMPONENTS

COUPLING TYPE	P. NUMBER			HUB NORMAL	HUB LONG	Sleeve NYLON
	GF NN	GF NL	GF LL			
GF 14	00101402	00101400	00101404	00101420	00101440	00101410
GF 19	00101902	00101900	00101904	00101920	00101940	00101910
GF 24	00102402	00102400	00102404	00102420	00102440	00102410
GF 28	00102802	00102800	00102804	00102820	00102840	00102810
GF 32	00103202	00103200	00103204	00103220	00103240	00103210
GF 38	00103802	00103800	00103804	00103820	00103840	00103810
GF 42	00104202	00104200	00104204	00104220	00104240	00104210
GF 48	00104802	00104800	00104804	00104820	00104840	00104810
GF 55	00105502	00105500	00105504	00105520	00105540	00105510
GF 65	00106502	00106500	00106504	00106520	00106540	00106510

MEASUREMENTS - WEIGHTS

COUPLING TYPE	without bore	Ød available holes with H7 tolerance		measurement in mm										Kg		
		ON REQUEST		for normal range hubs								long hubs series		sleeve	HUB normal	HUB long
		min	max	B	C	ØD	E	ØF	G	M	L	S				
GF 14	-	6	14	38	6,5	25	23,5	41	4	51	30	64	0,022	0,10	0,13	
GF 19	-	8	19	38	8,5	32	25,5	48	4	55	40	84	0,028	0,18	0,28	
GF 24	-	10	24	42	7,5	36	26,5	52	4	57	50	104	0,037	0,23	0,42	
GF 28	-	10	28	48	19	45	41	68	4	86	60	124	0,086	0,54	0,79	
GF 32	-	12	32	48	18	50	40	75	4	84	60	124	0,104	0,66	0,97	
GF 38	-	14	38	50	17	58	40	85	4	84	80	164	0,131	0,93	1,83	
GF 42	-	20	42	50	19	63	42	95	4	88	110	224	0,187	1,10	2,76	
GF 48	-	20	48	50	27	68	50	100	4	104	110	224	0,198	1,50	3,21	
GF 55	-	25	55	65	29,5	82	60	120	4	124	110	224	0,357	2,63	5,12	
GF 65	-	25	65	72	36	95	70	140	4	144	140	284	0,595	4,02	7,90	

GF NN

GF NL

GF LL



IMPORTANT

The GF couplings can be ordered complete or for single items.

CAD drawings available on our site
www.chiaravalli.com

Quantity, availability and prices
 on B2B Chiaravalli

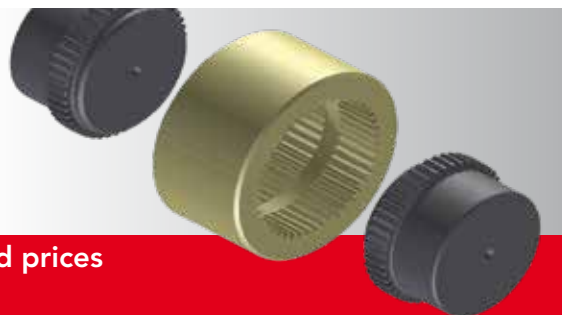



SERIES GFA



GFA COUPLING with Steel Sleeve



PRESENTATION

The **"GIFLEX®" GFA** range of flexible couplings represent couplings designed with a compact structure for industrial applications, torsionally rigid and capable of compensating angular, parallel and combined misalignments.

The special configuration with the single-piece sleeve and the seals at the two ends renders the couplings suitable for use in aggressive environments and in particularly demanding operating conditions. The performance complies with the characteristics of a dual articulation, constant-velocity coupling intended to be used both for general and specific applications and with the possibility of also being mounted on shafts with a large free gap.

The operating limits defined by the maximum torque, by the rotating speed and the permitted angular misalignment are the result of a design based on a targeted choice of materials, the heat treatment and the toothing geometry.

The reliability of the stated operating limits has been confirmed by testing the fatigue limits both at the surface pressure (Hertzian pressure) and at bending and to destructive wear in accordance with calculation schemes based on the most authoritative international standards.

The CHIARAVALLI GROUP SpA Technical Department is available however, to examine problems that relate to the choice, application and maintenance of couplings in collaboration with users.

On specific request, special couplings by their shape, execution and performance can be offered and produced, as an alternative to the normal execution couplings.

For example:

- Couplings designed for high angular and parallel misalignments.
- Couplings manufactured using high resistance steel and with surface hardening heat treatment.
- Couplings with case hardened and hardened hubs and using a hard metal tool).
- Special couplings manufactured to a drawing.

STRUCTURAL CHARACTERISTICS

The **GFA** range of compact couplings, comprise two toothed hubs and an external connecting single-piece sleeve.

The lubricant seal inside the coupling is ensured by two ring gaskets, arranged at the two ends of the sleeve and held in position by spring washers (Seeger washers).

Two threaded dowels arranged radially on the sleeve in a counter-position allow a solid lubricant to be adopted.

The toothing adopted for the two hubs is profile corrected and has a progressive dual curvature achieved by machine the toothing on a fully Numerically Controlled gear cutting machine.

The sleeve's profile corrected toothing, which has a parallel gene-ratrix, is obtained using a shaping tool.

The toothing is produced to category 7 precision, in compliance with DIN 3972 and has a degree of finish with a surface roughness of not more than $Ra = 1.4$ micrometres, thanks to the machining technology adopted.

Both the hubs and the sleeve are manufactured using hardened and tempered carbon steel with a tensile stress resistance of 800 N/mm. The couplings are subjected to a surface hardening thermo-chemical treatment at the end of the machining stage, which ensures a high resistance to wear and seizure and also confers a high resistance to corrosion caused by atmospheric agents.

The perfect seal achieved by the gaskets ensures the required lubricant containment and prevents penetration of contaminating elements from outside, thereby contributing to increase the average useful working life of the coupling, even if operating in an aggressive environment.

The two toothed hub bands are positioned at the maximum distance permitted by the sleeve length. This arrangement ensures a minimum angular misalignment for a given parallel misalignment and enhances the coupling's constant-velocity features.



The satisfactory operation and the useful working life of flexible toothed couplings depends on the correct selection of the couplings, as well as on the compatibility of the operating conditions with the performance provided by the coupling. It is essential therefore, to highlight the limiting performance of the couplings and to clarify the actions of the external loads that are exerted on the corresponding couplings.

The basic design ensures that all the couplings are capable of compensating a static angular or assembly misalignment equal to 1 degree and this is ensured by the minimum construction tolerance between the teeth.

The dynamic angular or operating misalignment must never be greater than 0.5 degrees, even if the recommended values should not be greater than 0.25 degrees.

The declared nominal torque values and the maximum rotating speeds indicated refer to an angular or composite misalignment that does not exceed 1/12 of a degree (5 prime divisions).

The 'exceptional' torque values that can be supported as a transient and during the acceleration phases must not be exerted for more than 10-15 seconds and must not occur for more than 5 events/hour.

Fatigue durations are calculated for a conventional limit of 50 million cycles, considering two load cycles for each revolution of the coupling.

Misalignments exceeding 1/8 degrees (7.5 prime divisions) penalise by decreasing the nominal torque and the maximum rotating speed declared for the individual couplings.

The performance of the coupling in terms of torque, limiting speed and useful working life will decrease or increase compared with the declared values in the case of operating conditions that differ from the conditions specified above or for "fixed-term" durations.

The design data has been tested for the purpose of ensuring a reasonable safety margin. The declared performance therefore, is to be understood as valid for a Service Factor equal to 1.

Use of the prescribed lubricants and compliance with the recommended restore time intervals represent the preconditions to achieve the performance as described

in the catalogue. The CHIARAVALLI GROUP SpA Technical Department is available to advise users in selecting the type of coupling most appropriate for the actual operating conditions and to make recommendations in relation to special operating conditions.

TECHNICAL DATA

COUPLING TYPE	Power Factor Kw		Torque Nm		Power transmitted in Kw at r.p.m.				r.p.m. max	r.p.m. recommended limit	max radial misalignment mm	mass kg	J kg cm ²
	normal	except.	normal	except.	750 normal	1000 normal	1500 normal	3000 normal					
GFA 25	0,061	0,157	600	1.524	45	61	91	183	6.000	5.000	0,20	1,36	8,68
GFA 32	0,103	0,259	1.000	2.520	77	103	154	309	5.000	4.000	0,26	2,51	25,10
GFA 40	0,128	0,322	1.250	3.125	96	128	192	384	4.200	3.000	0,32	3,55	44,82
GFA 56	0,257	0,639	2.500	6.200	192	257	385	-	3.500	2.200	0,37	6,15	132,60
GFA 63	0,412	0,985	4.000	9.260	309	412	618	-	3.000	1.600	0,40	9,91	278,20
GFA 80	0,773	1,855	7.500	18.000	579	773	-	-	2.600	1.200	0,48	16,20	558,6
GFA 100	1,236	2,937	12.000	28.500	927	-	-	-	1.400	700	0,65	23,00	1.044,50
GFA 125	2,431	5,795	23.600	56.250	1.823	-	-	-	950	460	0,70	49,15	3.650
GFA 155	4,121	9,273	40.000	90.000	3.090	-	-	-	700	350	0,80	91,30	9.982

N.B. Class G 2.5 dynamic balancing in compliance with ISO 1940 is recommended for actual operating speeds that exceed 3,600 r.p.m. Couplings can operate with a parallel misalignment value that is double the suggested value and assembly with a misalignment value that is four times greater than the suggested value in exceptional cases.

CAD drawings available on our site
www.chiaravalli.com

(1) Referred to the normal coupling complete with maximum bore without keyway.

**Quantity, availability and prices
on B2B Chiaravalli**



The torque, speed and useful working life data declared for the couplings are to be understood as valid referred to a Service Factor SF = 1.

The service factor must be determined therefore, based on the type of load, the load intensity and the range factor that characterises the type of load exerted on the coupling.

The values shown in the following table can be considered as a precautionary measure in the absence of reliable service factor design data.

LOAD CONDITION	OPERATING CONDITIONS	TYPE OF DRIVE	
		electric motor	diesel engine
UNIFORM	Regular operation without impacts or overloads	1,25	1,5
LIGHT	Regular operation with minor and infrequent impacts and overloads	1,50	2,0
MEDIUM	Irregular operation with medium overloads for a short duration and frequent but moderate impacts	2,0	2,5
HEAVY	Markedly irregular operation with very frequent impacts and overloads and of major intensity.	2,5	3,0

TEST BASED ON THE POWER TO BE TRANSMITTED

Use the following formula to calculate the value of the operating torque (Me) expressed in Nm, considering the drive motor power output (P) in kW and the operating speed (n) in r.p.m.

$$Me = \frac{9549 \times P}{n}$$

Establish the nominal torque to be transmitted (Mn) based on the service factor taken from the table.

$$Mn = Me \times FS$$

Select the coupling with a nominal torque which is GREATER than the value calculated.

WARNING

The declared nominal torques must be progressively decreased for angular misalignments that exceed 0.125 degrees.

TEST BASED ON THE SHAFT DIAMETER

Check that the largest of the shafts to be connected has a diameter equal to or less than the nominal bore declared for the coupling.

The maximum permitted diameter for the selected coupling should be limited to UNIFORM or LIGHT load conditions.



TEST BASED ON THE ROTATING SPEED

The maximum rotating speed indicated for each coupling represents an operating limit calculated for an angular misalignment that does not exceed 1/12 of a degree. Both the nominal torque and the permitted rotating speed are reduced for greater angular misalignments. Adopt a coefficient equal to 1.12 to increase the service factor and select the coupling as described previously when both the misalignment and the operating speed are less than the suggested reference values, but are close to these values. Contact our Technical Services for operating conditions with misalignments and operating speeds that exceed the suggested reference values.

TEST BASED ON THE REQUIRED USEFUL WORKING LIFE

Nominal operating conditions (torque, misalignment and rotating speed). Operating lifespans that exceed the standard duration cause the nominal torque to decrease.

The service factor must be multiplied by a lifespan coefficient defined as follows if a given operating lifespan, which exceeds the standard working lifespan, is required.

OPERATING LIFESPAN IN HOURS	3800	4000	6000	8000	12000	20000
LIFESPAN COEFFICIENT	1	1,06	1,17	1,26	1,39	1,58

The nominal torque verified for the lifespan must be further decreased in the fairly improbable circumstance in which the actual operating speed is greater than the maximum permitted operating speed for the misalignment conditions of the coupling when in operation.

COMPONENT PARTS OF THE "GIFLEX®" GFA COUPLING

COUPLING TYPE	POS. 1		POS. 2		POS. 3		POS. 4		POS. 5		Allen wrench	N° of pieces
	description	N° of pieces	description	N° of pieces	Seal ring Corteco NBR DIN 3760 A	N° of pieces	Flexible ring for bores DIN 472	N° of pieces	Flat dowel UNI 5923	N° of pieces		
GFA 25	sleeve	1	HUB	2	BA 42x56x7	2	56 I	2	M 6x8	2	D.3	1
GFA 32	sleeve	1	HUB	2	BA 56x72x8	2	72 I	2	M 6x8	2	D.3	1
GFA 40	sleeve	1	HUB	2	BA 64x80x8	2	80 I	2	M 6x8	2	D.3	1
GFA 56	sleeve	1	HUB	2	BA 80x100x10	2	100 I	2	M 6x8	2	D.3	1
GFA 63	sleeve	1	HUB	2	BA 100x125x12	2	125 I	2	M 6x8	2	D.3	1
GFA 80	sleeve	1	HUB	2	BA 125x160x12	2	160 I	2	M 6x8	2	D.3	1
GFA 100	sleeve	1	HUB	2	SMIM 150x180x12	2	180 I	2	M 6x8	2	D.3	1
GFA 125	sleeve	1	HUB	2	SM 190x220x15	2	220 I	2	M 6x8	2	D.3	1
GFA 155	sleeve	1	HUB	2	SMIM 240x280x15	2	280 I	2	M 6x8	2	D.3	1

COMPONENT PARTS OF THE "GIFLEX®" GFAS COUPLING

COUPLING TYPE	POS. 1		POS. 2		POS. 3		POS. 4		POS. 5		Allen wrench	N° of pieces
	description	N° of pieces	description	N° of pieces	Seal ring Serie UM Gaco NBR	N° of pieces	Flexible ring for bores DIN 471	N° of pieces	Flat dowel UNI 5923	N° of pieces		
GFAS 25	sleeve	1	HUB	1	UM 60x40x10	1	40 E	1	M 6x8	2	D.3	1
GFAS 32	sleeve	1	HUB	1	UM 75x55x10	1	55 E	1	M 6x8	2	D.3	1
GFAS 40	sleeve	1	HUB	1	UM 85x65x10	1	65 E	1	M 6x8	2	D.3	1
GFAS 56	sleeve	1	HUB	1	UM 100x80x10	1	80 E	1	M 6x8	2	D.3	1
GFAS 63	sleeve	1	HUB	1	UM 120x100x10	1	100 E	1	M 6x8	2	D.3	1
GFAS 80	sleeve	1	HUB	1	UM 155x125x15	1	125 E	1	M 6x8	2	D.3	1
GFAS 100	sleeve	1	HUB	1	UM 180x150x15	1	150 E	1	M 6x8	2	D.3	1



NORMAL HUB



LONG HUB



SLEEVE STEEL

GFA ASSEMBLY

- A)** Insert the stop ring (4) and the seal ring (2) on the shaft.
- B)** Assemble the hubs (2) on the relative shafts.
- C)** Sleeve (1) is to be fitted on the longest shaft.
- D)** Position the shafts close together and check that the distance G corresponds to the value indicated in the table.
- E)** Align the shafts and check the parallelism then tighten the hubs on the shaft.
- F)** Fill the tothing and the gap between the hubs with grease.
- G)** At this stage slide the sleeve (1) down and position the sealing rings (3) in its place and tighten the stop rings (4) in their seat.
- H)** Proceed as follows for disassembly: remove the stop rings (4) using a pair of pliers, separate the sleeve (1) from the hubs (2) and the GFA coupling is fully disassembled.

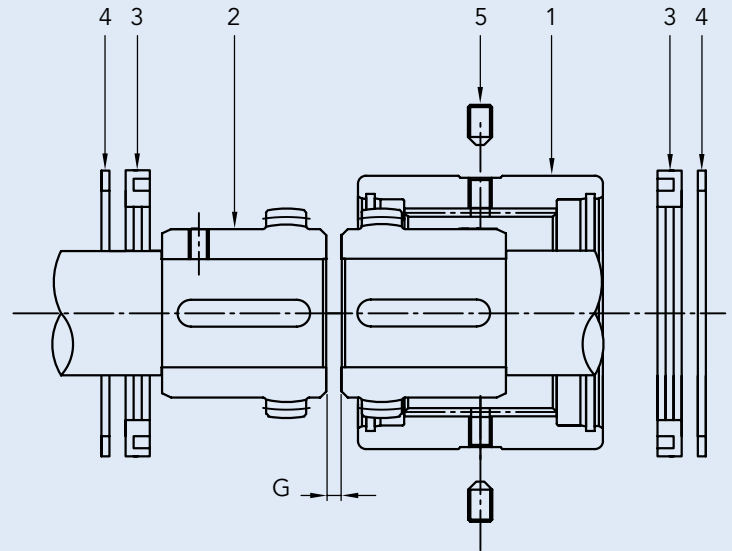
MAINTENANCE

Unscrew both plugs (5) then introduce grease using the grease gun through the greasing holes until the grease exits from the other hole positioned at 180°. Replace the plugs. Repeat this operation every 1.000 working hours.

Equivalent recommended greases are as follows:

TYPE	PRODUCER
Sovarex L-O	MOBIL OIL
Gulfrown EP-O	GULF OIL
Alesia EP-2	SHELL OIL
....

Couplings require lubrication with grease, the quantity of grease used should half fill the available gap.

Use of Lithium soap grease with a base mineral oil and consistency index 2 (in compliance with NLGI) is recommended for moderate loads and normal operating conditions.

Use Barium complex soap grease, PAO synthetic base oil and consistency index 2 for heavy-duty operating conditions as regards temperatures and with heavy loads.

Contact the CHIARAVALLI GROUP SpA Technical Department for extreme operating conditions.

The lubricant complying with the formulation and with the recommended characteristics can be selected from among the range of products indicated below by consulting the Producer.

N.B.

The technical characteristics, the dimensions and all other data contained in this catalogue are not binding.

CHIARAVALLI GROUP SpA reserves the right to change the measurements indicated at any time and without notice.



STEEL SLEEVE

INTERPRETATION CODES

EXAMPLE

GFA 25-NN with 2 normal hubs

GFA 25-NL with 1 normal hubs
and 1 long hub

GFA 25-LL with 2 long hubs

The characteristic size of the coupling is defined by the maximum diameter bore.

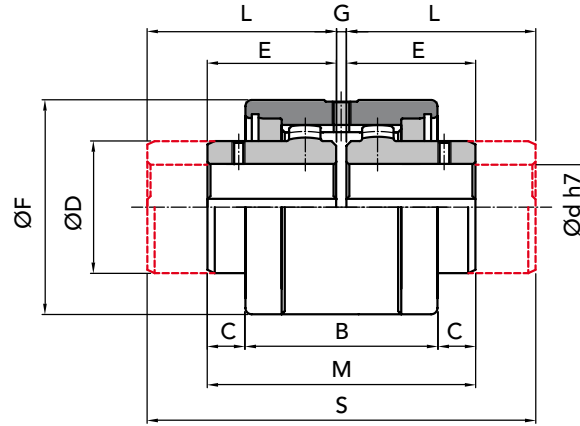

PART NUMBERS FOR COMPLETE COUPLING

PART NUMBERS FOR SIMPLE COMPONENTS

COUPLING TYPE	P. NUMBER GFA NN	P. NUMBER GFA NL	P. NUMBER GFA LL	SLEEVE	HUB NORMAL	HUB LONG	COMPONENTS to assembled coupling
GFA 25	00202502	00202500	00202504	00202510	00202520	00202540	00202560
GFA 32	00203202	00203200	00203204	00203210	00203220	00203240	00203260
GFA 40	00204002	00204000	00204004	00204010	00204020	00204040	00204060
GFA 56	00205602	00205600	00205604	00205610	00205620	00205640	00205660
GFA 63	00206302	00206300	00206304	00206310	00206320	00206340	00206360
GFA 80	00208002	00208000	00208004	00208010	00208020	00208040	00208060
GFA 100	00210002	00210000	00210004	00210010	00210020	00210040	00210060
GFA 125	00212502	00212500	00212504	00212510	00212520	00212540	00212560
GFA 155	00215502	00215502	00215504	00215510	00215520	00215540	00215560

MEASUREMENTS - WEIGHTS

COUPLING TYPE	Ø bore nom.	Ød available holes with H7 tolerance		measures in mm									Kg		
		ON REQUEST		normal series						long series			sleeve	HUB normal	HUB long
		min	max	B	C	ØD	E	ØF	G	M	L	S			
GFA 25	-	25	28	61	12	42	41	68	3	85	60	123	0,72	0,48	0,69
GFA 32	-	32	38	73	13,5	55	48,5	85	3	100	80	163	1,14	0,99	1,58
GFA 40	-	40	48	82	16,5	64	56	95	3	115	80	163	1,68	1,49	2,10
GFA 56	-	56	60	97	21,5	80	68	120	4	140	100	204	2,86	2,96	4,22
GFA 63	-	63	70	108	22,5	100	74,5	140	4	153	119,5	243	3,75	4,90	7,67
GFA 80	-	80	90	125	22,5	125	82,5	175	5	170	140	285	5,58	8,72	14,26
GFA 100	-	100	110	148	34	150	105	198	6	216	174,5	355	6,63	15,76	25,40
GFA 125*	40	125	140	214	39	190	140	245	8	288	207,5	423	17,70	32,60	49,50
GFA 155*	40	155	175	240	64	240	180	300	10	370	245	498	28,30	65,50	91,40

* Row material quenched steel 39NiCrMo3



On request: we execute machining for finish bore and keyway.

IMPORTANT

The GFA couplings can be ordered complete or for single items.

CAD drawings available on our site
www.chiaravalli.com

Quantity, availability and prices
on B2B Chiaravalli

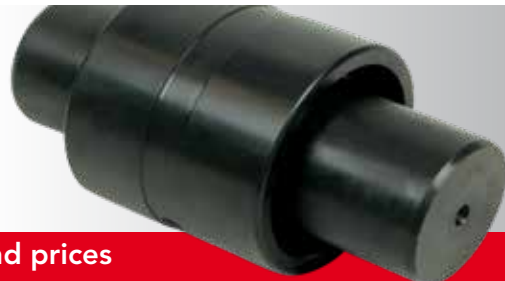

FLEXIBLE TOOTHED COUPLINGS WITH DUAL CURVATURE "GIFLEX" SERIES GFA with STEEL SLEEVE



FLEXIBLE TOOTHED COUPLINGS WITH DUAL CURVATURE "GIFLEX®" SERIES GFAS

SERIES GFAS



GFAS COUPLING WITH STEEL BELL



PRESENTATION

The **"GIFLEX®" GFAS** range of flexible couplings represent couplings designed with a compact structure for industrial applications, torsionally rigid and capable of compensating angular, parallel and combined misalignments.

The special configuration with the single-piece sleeve and the seals at the two ends renders the couplings suitable for use in aggressive environments and in particularly demanding operating conditions. The performance complies with the characteristics of a dual articulation, constant-velocity coupling intended to be used both for general and specific applications and with the possibility of also being mounted on shafts with a large free gap.

The operating limits defined by the maximum torque, by the rotating speed and the permitted angular misalignment are the result of a design based on a targeted choice of materials, the heat treatment and the toothing geometry.

The reliability of the stated operating limits has been confirmed by testing the fatigue limits both at the surface pressure (Hertzian pressure) and at bending and to destructive wear in accordance with calculation schemes based on the most authoritative international standards.

The CHIARAVALLI GROUP SpA Technical Department is available however, to examine problems that relate to the choice, application and maintenance of couplings in collaboration with users.

On specific request, special couplings by their shape, execution and performance can be offered and produced, as an alternative to the normal execution couplings.

For example:

- Couplings designed for high angular and parallel misalignments.
- Couplings manufactured using high resistance steel and with surface hardening heat treatment.
- Couplings with case hardened and hardened hubs and toothing finished by machine tools after heat treatment (skiving using a hard metal tool).
- Special couplings manufactured to a drawing.

STRUCTURAL CHARACTERISTICS

The **GFAS** range of compact couplings, comprise two toothed hubs and an external connecting single-piece sleeve.

The lubricant seal inside the coupling is ensured by two ring gaskets, arranged at the two ends of the sleeve and held in position by spring washers (Seeger washers).

Two threaded dowels arranged radially on the sleeve in a counter-position allow a solid lubricant to be adopted.

The toothing adopted for the two hubs is profile corrected and has a progressive dual curvature achieved by machine the toothing on a fully Numerically Controlled gear cutting machine.

The sleeve's profile corrected toothing, which has a parallel generatrix, is obtained using a shaping tool.

The toothing is produced to category 7 precision, in compliance with DIN 3972 and has a degree of finish with a surface roughness of not more than $Ra = 1.4$ micrometres, thanks to the machining technology adopted.

Both the hubs and the sleeve are manufactured using hardened and tempered carbon steel with a tensile stress resistance of 800 N/mm. The couplings are subjected to a surface hardening thermo-chemical treatment at the end of the machining stage, which ensures a high resistance to wear and seizure and also confers a high resistance to corrosion caused by atmospheric agents.

The perfect seal achieved by the gaskets ensures the required lubricant containment and prevents penetration of contaminating elements from outside, thereby contributing to increase the average useful working life of the coupling, even if operating in an aggressive environment.

The two toothed hub bands are positioned at the maximum distance permitted by the sleeve length. This arrangement ensures a minimum angular misalignment for a given parallel misalignment and enhances the coupling's constant-velocity features.



The satisfactory operation and the useful working life of flexible toothed couplings depends on the correct selection of the couplings, as well as on the compatibility of the operating conditions with the performance provided by the coupling. It is essential therefore, to highlight the limiting performance of the couplings and to clarify the actions of the external loads that are exerted on the corresponding couplings.

The basic design ensures that all the couplings are capable of compensating a static angular or assembly misalignment equal to 1 degree and this is ensured by the minimum construction tolerance between the teeth.

The dynamic angular or operating misalignment must never be greater than 0.5 degrees, even if the recommended values should not be greater than 0.25 degrees.

The declared nominal torque values and the maximum rotating speeds indicated refer to an angular or composite misalignment that does not exceed 1/12 of a degree (5 prime divisions).

The 'exceptional' torque values that can be supported as a transient and during the acceleration phases must not be exerted for more than 10-15 seconds and must not occur for more than 5 events/hour.

Fatigue durations are calculated for a conventional limit of 50 million cycles, considering two load cycles for each revolution of the coupling.

Misalignments exceeding 1/8 degrees (7.5 prime divisions) penalise by decreasing the nominal torque and the maximum rotating speed declared for the individual couplings.

The performance of the coupling in terms of torque, limiting speed and useful working life will decrease or increase compared with the declared values in the case of operating conditions that differ from the conditions specified above or for "fixed-term" durations.

The design data has been tested for the purpose of ensuring a reasonable safety margin. The declared performance therefore, is to be understood as valid for a Service Factor equal to 1.

Use of the prescribed lubricants and compliance with the recommended restore time intervals represent the preconditions to achieve the performance as described

in the catalogue. The CHIARAVALLI GROUP SpA Technical Department is available to advise users in selecting the type of coupling most appropriate for the actual operating conditions and to make recommendations in relation to special operating conditions.

TECHNICAL DATA

COUPLING TYPE	Power Factor		Torque		Power transmitted in Kw				r.p.m. max	r.p.m. recommended limit	max radial misalignment mm	mass kg	J kg cm ²
	Kw normal	Kw except.	Nm normal	Nm except.	750 normal	1000 normal	1500 normal	3000 normal					
GFAS 25	0,061	0,157	600	1.524	45	61	91	183	6.000	5.000	-	1,35	7,31
GFAS 32	0,103	0,259	1.000	2.520	77	103	154	309	5.000	4.000	-	2,43	19,15
GFAS 40	0,128	0,322	1.250	3.125	96	128	192	384	4.200	3.000	-	3,64	34,13
GFAS 56	0,257	0,639	2.500	6.200	192	257	385	-	3.500	2.200	-	6,07	96,56
GFAS 63	0,412	0,985	4.000	9.260	309	412	618	-	3.000	1.600	-	10,00	207,32
GFAS 80	0,773	1,855	7.500	18.000	579	773	-	-	2.600	1.200	-	19,18	492,6
GFAS 100	1,236	2,937	12.000	28.500	927	-	-	-	1.400	700	-	28,00	1.064,00

N.B. Class G 2.5 dynamic balancing in compliance with ISO 1940 is recommended for actual operating speeds that exceed 3,600 r.p.m. Couplings can operate with a parallel misalignment value that is double the suggested value and assembly with a misalignment value that is four times greater than the suggested value in exceptional cases.

CAD drawings available on our site
www.chiaravalli.com

(1) Referred to the normal coupling complete with maximum bore without keyway.

Quantity, availability and prices
 on B2B Chiaravalli



NORMAL HUB



LONG HUB



NORMAL CONE



LONG CONE

GFAS ASSEMBLY

- A)** The seal ring (3) and stop ring (4) are already fitted on the extractable hub (2).
- B)** Assembly in closed cone mode only requires the sleeve (1) to be fixed onto one shaft and the extractable hub (2) to be tightened on the other shaft.
- C)** Then arrange the shafts to be connected closely together, positioning the hub (2) over the sleeve (1).
- D)** To disassemble, separate the shafts then extract the hub (2) from the sleeve (1).

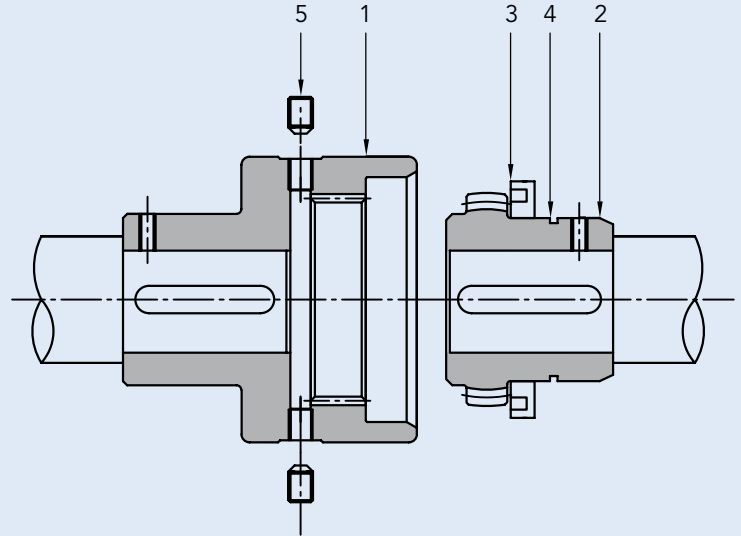
Equivalent recommended greases are as follows:

TYPE	PRODUCER
Sovarex L-O	MOBIL OIL
Gulfrown EP-O	GULF OIL
Alesia EP-2	SHELL OIL
....

Couplings require lubrication with grease, the quantity of grease used should half fill the available gap.

Use of Lithium soap grease with a base mineral oil and consistency index 2 (in compliance with NLGI) is recommended for moderate loads and normal operating conditions.

Use Barium complex soap grease, PAO synthetic base oil and consistency index 2 for heavy-duty operating conditions as regards temperatures and with heavy loads.

Contact the CHIARAVALLI GROUP SpA Technical Department for extreme operating conditions.

The lubricant complying with the formulation and with the recommended characteristics can be selected from among the range of products indicated below by consulting the Producer.

N.B.

The technical characteristics, the dimensions and all other data contained in this catalogue are not binding.

CHIARAVALLI GROUP SpA reserves the right to change the measurements indicated at any time and without notice.



CONE IN STEEL

INTERPRETATION CODES

- Example
GFAS 25-NN with cone and a normal hub
GFAS 25-NL with cone and a long hub
GFAS 25-LL with long cone and a long hub
GFAS 25-LN with long cone and a normal hub

The characteristic size of the coupling is defined by the maximum diameter bore.

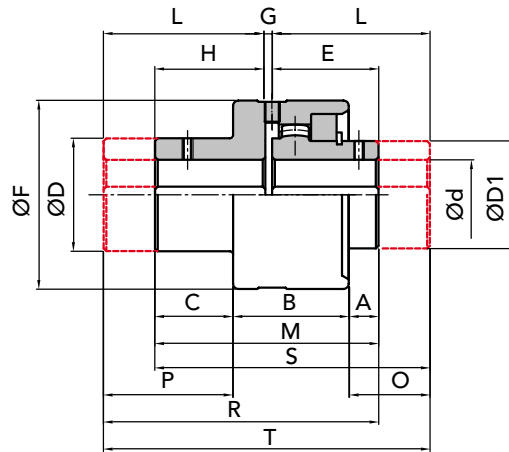

PART NUMBERS FOR COMPLETE COUPLING

PART NUMBERS FOR SIMPLE COMPONENTS

COUPLING TYPE	P.NUMBER GFAS NN	P.NUMBER GFAS NL	P.NUMBER GFAS LN	P.NUMBER GFAS LL	CONE NORMAL	CONE LONG	HUB NORMAL	HUB LONG	COMPONENTS to assembled coupling
GFAS 25	00302502	00302500	00302506	00302504	00302510	00302511	00302520	00302540	00302560
GFAS 32	00303202	00303200	00303206	00303204	00303210	00302511	00303220	00303240	00303260
GFAS 40	00304002	00304000	00304006	00304004	00304010	00304011	00304020	00304040	00304060
GFAS 56	00305602	00305600	00305606	00305604	00305610	00305611	00305620	00305640	00305660
GFAS 63	00306302	00306300	00306306	00306304	00306310	00306311	00306320	00306340	00306360
GFAS 80	00308002	00308000	00308006	00308004	00308010	00308011	00308020	00308040	00308060
GFAS 100	00310002	00310000	00310006	00310004	00310010	00310011	00310020	00310040	00310060

MEASUREMENTS - WEIGHTS

COUPLING TYPE	without bore		Ød finished bore		measures in mm																Kg			
	min	max	min	max	normal series								long series								normal bell	normal HUB	long bell	long HUB
					A	B	C	ØD	ØD1	E	ØF	G	H	M	I	L	O	P	R	S				
GFAS 25	-	25	28	13	43	29	42	40	41	70	3	41	85	60	60	32	48	104	104	123	1,03	0,48	1,30	0,69
GFAS 32	-	32	38	16	49	35	55	55	48,5	85	3	48,5	100	80	80	47,5	66,5	131,5	131,5	163	1,75	0,99	2,50	1,58
GFAS 40	-	40	48	18,5	54,5	42	64	64	56	95	3	56	115	80	80	42,5	66	139	139	163	2,71	1,49	3,40	2,10
GFAS 56	-	56	60	27	60	45	80	80	68	120	4	60	132	100	100	59	85	172	164	204	4,43	2,96	6,10	4,22
GFAS 63	-	63	75	31	63	46	100	100	74,5	140	4	61,5	140	119,5	119,5	76	104	198	185	243	6,62	4,90	10,20	7,67
GFAS 80	-	80	90	26	76	51	125	125	82,5	175	5	65,5	153	138	140	83,5	123,5	225,5	210,5	283	10,50	8,68	17,90	14,22
GFAS 100	-	100	110	38	92	71	150	150	105	198	6	90	201	162	174,5	107,5	143	273	270,5	342,5	28,2	15,70	38,1	25,30

GFAS NN

GFAS NL

GFAS LL

GFAS LN



NORMAL HUB



LONG HUB



NORMAL BELL



LONG BELL

IMPORTANT

The GFAS couplings can be ordered complete or for single items.



CAD drawings available on our site
www.chiaravalli.com

Quantity, availability and prices on B2B Chiaravalli



FLEXIBLE TOOTHED COUPLINGS WITH NYLON SLEEVE

FLEXIBLE TOOTHED COUPLINGS WITH NYLON SLEEVE "GIFLEX®" SERIES FBX

SERIES FBX



GIFLEX® FBX COUPLING WITH NYLON SLEEVE



NORMAL HUB



LONG HUB



NYLON SLEEVE



COUPLING SELECTION

Torque based selection:
the coupling must be selected in order that the maximum torque motor does not exceed the coupling's permitted twisting moment peak.

TECHNICAL DATA

COUPLING TYPE	Power factor Kw r.p.m.		Torque Nm		power transmitted in kw at r.p.m.								r.p.m. max	mass kg	J kg cm ²	Maximum misalignment for each hub		Axial displacement mm
	norm	max	norm	max	750		1000		1500		3000					Angular α	Radial mm	
					norm	max	norm	max	norm	max	norm	max						
FBX 14	0,0010	0,0 020	10	20	0,80	1,56	1,05	2,10	1,58	3,14	3,12	6,24	14.000	0,12	0,27	± 2°	0,7	± 1
FBX 19	0,0017	0,0033	16	32	1,25	2,50	1,67	3,34	2,52	5,02	5,04	10,08	12.000	0,19	0,55	± 2°	0,8	± 1
FBX 24	0,0021	0,0042	20	40	1,58	3,15	2,10	4,20	3,14	6,28	6,26	12,52	10.500	0,23	0,96	± 2°	0,8	± 1
FBX 28	0,0047	0,0092	45	90	3,52	7,07	4,72	9,43	7,08	14,12	14,14	28,28	8.500	0,59	3,20	± 2°	1	± 1
FBX 32	0,0063	0,0127	60	120	4,70	9,43	6,28	12,58	9,40	18,85	18,83	37,66	7.500	0,78	5,60	± 2°	1	± 1
FBX 38	0,0084	0,0168	80	160	6,28	12,57	8,38	16,76	12,56	25,12	25,12	50,24	6.500	0,95	9,59	± 2°	0,9	± 1
FBX 42	0,0105	0,0210	100	200	7,85	15,72	10,47	20,93	15,70	31,40	31,42	62,84	6.000	1,32	13,90	± 2°	0,9	± 1
FBX 48	0,0147	0,0292	140	280	11,00	22,00	14,67	29,32	22,00	43,98	43,96	87,92	5.600	1,53	18,15	± 2°	0,9	± 1
FBX 55	0,0280	0,0565	275	555	20,80	39,50	27,80	52,00	42,50	85,00	84,60	169,20	4.800	2,30	49,44	± 2°	1,2	± 1
FBX 65	0,0398	0,0798	380	760	29,85	59,70	39,78	79,58	59,70	119,36	119,37	238,74	4.000	3,25	108,40	± 2°	1,3	± 1



NYLON SLEEVE

INTERPRETATION CODES

Example

FBX 19-NN with 2 normal hubs

FBX 19-NL with 1 normal hubs
and 1 long hub

FBX 19-LL with 2 long hubs

The characteristic size of the coupling is defined by the maximum diameter bore.

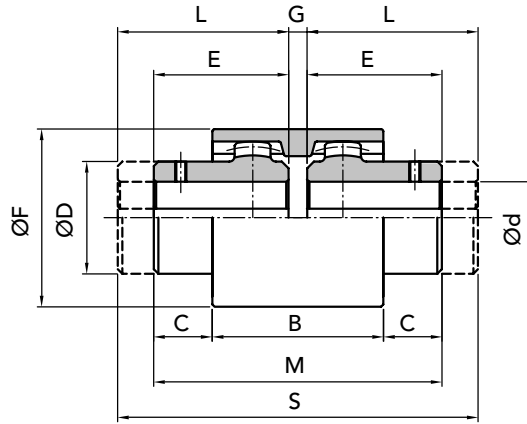

PART NUMBERS

COUPLING TYPE	PART NUMBER FBX NN	PART NUMBER FBX NL	PART NUMBER FBX LL	HUB NORMAL	HUB LONG	NYLON SLEEVE
FBX 14	00501402	00501400	00501404	00501420	00501440	00501410
FBX 19	00501902	00501900	00501904	00501920	00501940	00501910
FBX 24	00502402	00502400	00502404	00502420	00502440	00502410
FBX 28	00502802	00502800	00502804	00502820	00502840	00502810
FBX 32	00503202	00503200	00503204	00503220	00503240	00503210
FBX 38	00503802	00503800	00503804	00503820	00503840	00503810
FBX 42	00504202	00504200	00504204	00504220	00504240	00504210
FBX 48	00504802	00504800	00504804	00504820	00504840	00504810
FBX 55	00505502	00505500	00505504	00505520	00505540	00505510
FBX 65	00506502	00506500	00506504	00506520	00506540	00506510

MEASUREMENTS - WEIGHTS

COUPLING TYPE	hub without hole	Ød finished bore		measurement in mm										Kg SLEEVE	HUB normal	HUB long
		min.	max.	normal series					long series							
				B	C	ØD	E	ØF	G	M	L	S				
FBX 14	-	6	14	37	6,5	25	23	40	4	50	40	84	0,02	0,06	0,10	
FBX 19	-	8	19	37	8,5	32	25	48	4	54	40	84	0,03	0,09	0,13	
FBX 24	-	10	24	41	7,5	36	26	52	4	56	50	104	0,04	0,11	0,21	
FBX 28	-	10	28	46	19	44	40	66	4	84	55	114	0,07	0,28	0,38	
FBX 32	-	12	32	48	18	50	40	76	4	84	60	114	0,09	0,37	0,50	
FBX 38	-	14	38	48	18	58	40	83	4	84	60	124	0,11	0,46	0,70	
FBX 42	-	20	42	50	19	65	42	92	4	88	60	124	0,14	0,64	0,90	
FBX 48	-	20	48	50	27	68	50	95	4	104	60	124	0,16	0,74	1,00	
FBX 55	-	25	55	58	25	82	52	114	4	108	65	134	0,26	1,12	1,41	
FBX 65	-	25	65	68	23	96	55	132	4	114	70	144	0,39	1,59	2,04	



IMPORTANT

The FBX couplings can be ordered complete or for single items.

CAD drawings available on our site
www.chiaravalli.com

Quantity, availability and prices
 on B2B Chiaravalli



TORQUE LIMITERS

TORQUE LIMITERS	page 43
TORQUE LIMITERS WITH CHAIN COUPLING LCG	47
CHAIN COUPLING WITH KC COVER	48





LC 40 - 1

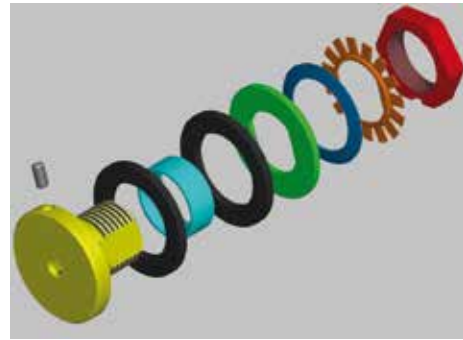

LC 85 - 2

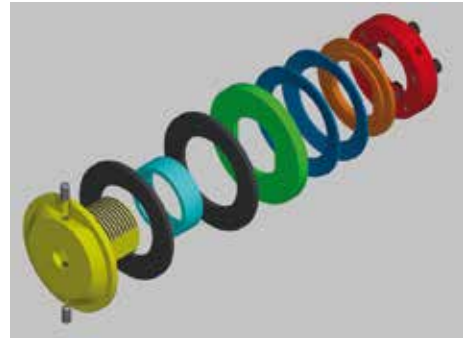

LC 95 - 1

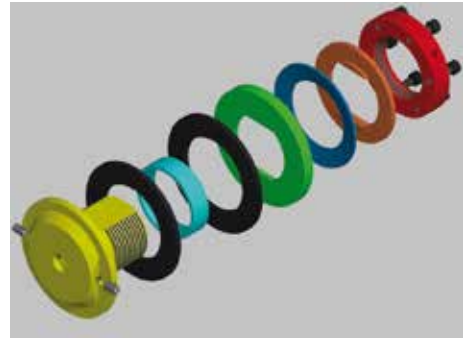

LC 170 - 2

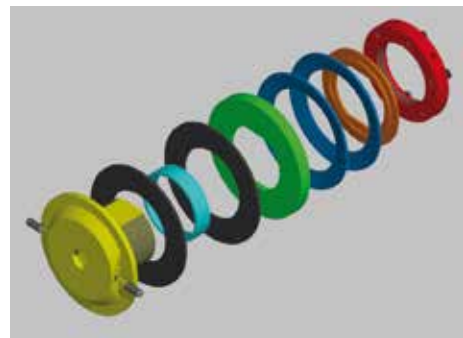



The torque limiter finds employment where an overloaded protection on mechanic transmission components is necessary (kinematics and machines).

The employment system easy and efficient, offers full operative reliability when the required torque exceeds the preloaded value and automatically restores the transmission when the overloaded ceases.

The transmission mechanical component, between pulleys, chain wheels and gears is within clutch that elements that tighten through the compression of the Bauer springs develops a friction force defined by the clamping of the sleeve.

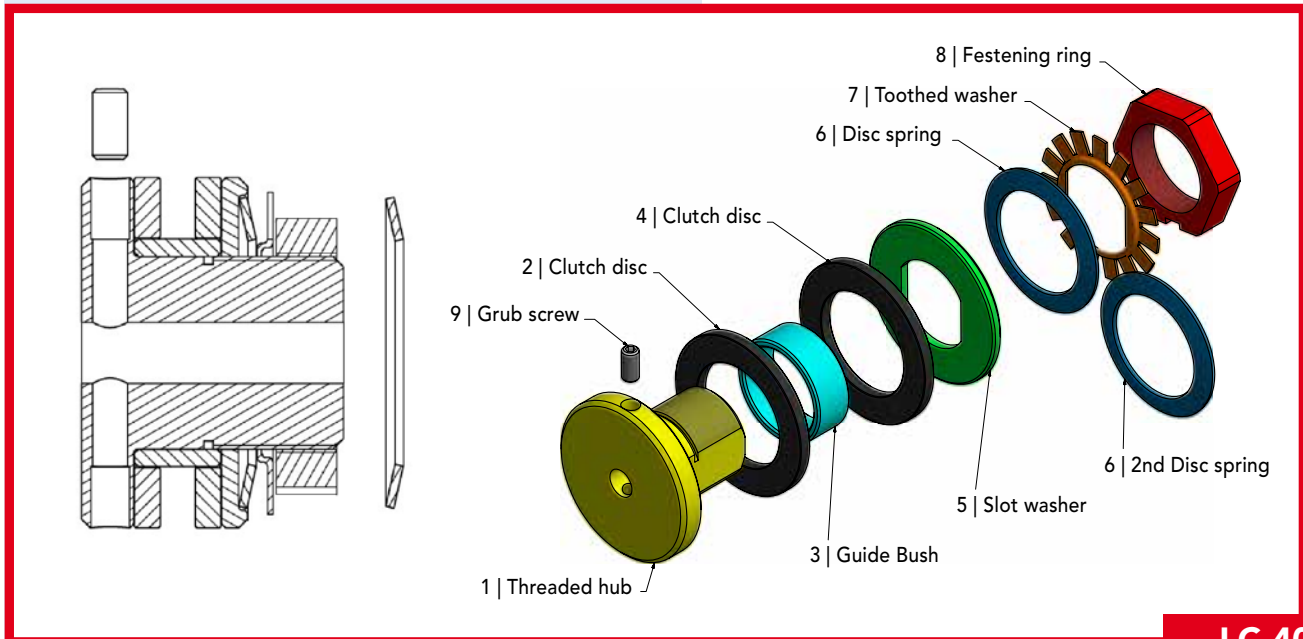

LC 40-50

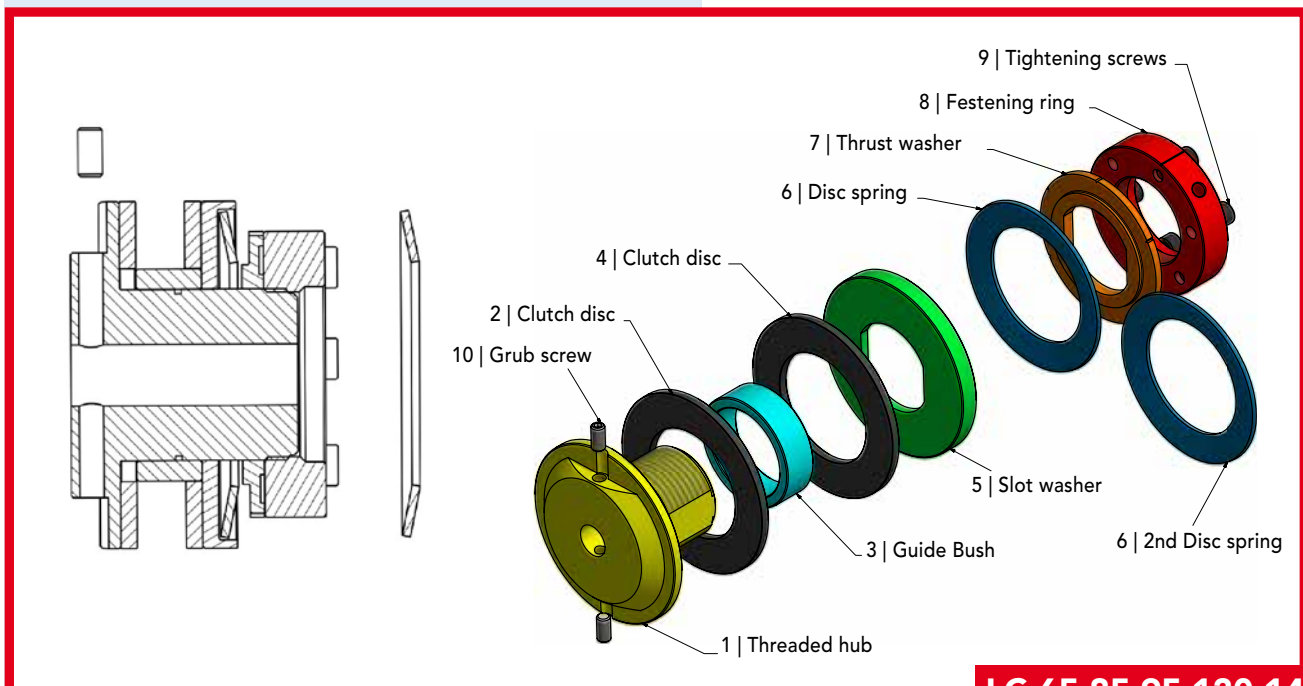

LC 65-85-95-120-140-170



CHOICE OF THE TORQUE LIMITER:

Tkw = Power in kW
 n = revolutions per minut
 Mt = torque (Nm)

The torque is given by the relation:

$$Mt = \frac{9550 \cdot Tkw}{n}$$

Example:

To use an electrical motor with the following features:

Power 4 kW e n = 1.550 g/1'

$$Mt = \frac{9550 \cdot 4}{1550} = 24.64 \text{ Nm}$$

So we will choose a limiter with a torque equal to or higher than 24,64 Nm



1 spring

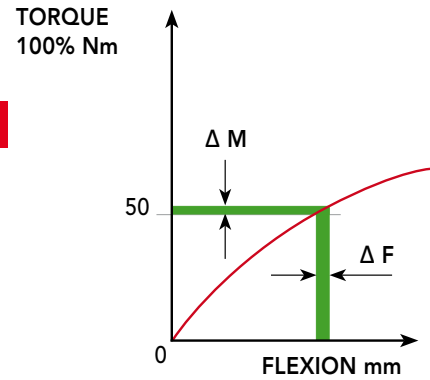

2 springs

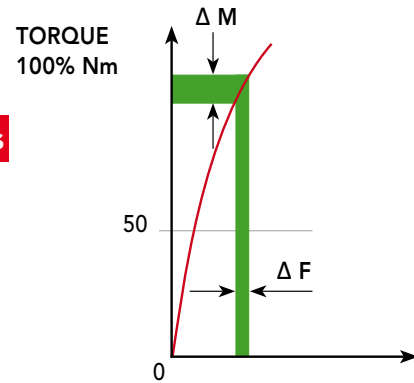

Scheme of the Belleville springs DIN 2093

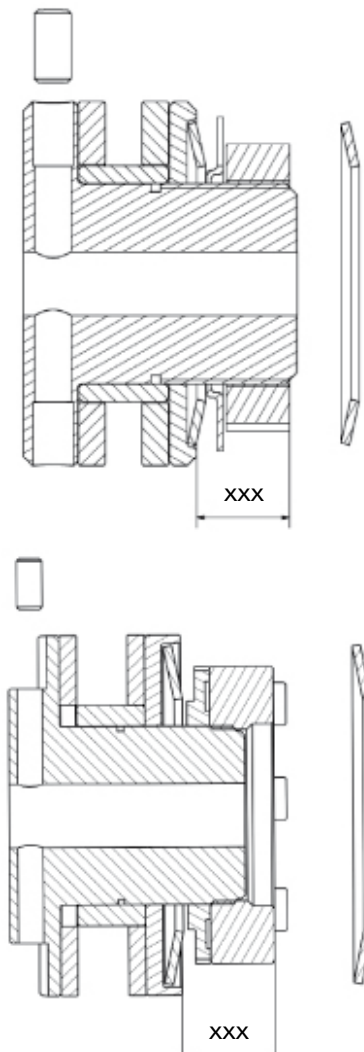

TYPE	TORQUE N/m	SPRINGS	R mm
LC 40	15	1	0,59
	28	2	0,53
LC 50	32	1	0,72
	60	2	0,57
LC 65	70	1	0,65
	120	2	0,55
LC 85	130	1	1,65
	240	2	1,35
LC 95	190	1	1,15
	340	2	0,95
LC 120	350	1	2
	650	2	1,75
LC 140	650	1	2,1
	1200	2	1,85
LC 170	1000	1	2,3
	1800	2	1,95

Manually tighten the nut until closing (xxx).

To get the maximum torque use the wrench to tighten further (xxx-R).

The ring nut is held in position by tightening screws.



The CHIARAVALLI limiter is assembled with a single spring.
The second spring is also present in the KIT.

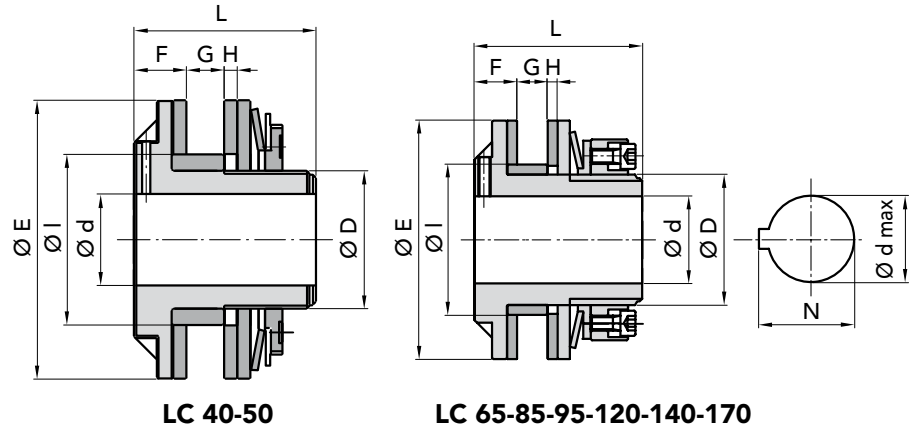

LC 40-50

LC 65-85-95-120-140-170

TYPE	Limiter part number	Dished plate spring part number	Disk Friction part number	Part number bushing	ØE	ØIh8	Ød	F	G	H	ØD	L	max. bore keyway DIN 6885/1 on request		Max torque N/m	N° of springs	sprockets for chain (u) = 1,6 : 2	N° teeth	Weight Kg.					
													Ød max	N						DIN2093	Ø pitch for roller			
LC 40	08040000	08040050	08040020	08040030	40	26	7	9	6	3	22	30	14	16,3	15	1	3/8" x 6,65	18-21	0,190					
																				28	2	1/2" x 8,51	15	0,195
LC 50	08050000	08050050	08050020	08050030	50	35	7	10	6	3	32	35,5	20	22,8	30	1	3/8" x 6,65	19-23	0,365					
																				55	2	1/2" x 8,51	17	0,370
LC 65	08065000	08065050	08065020	08065030	65	45	10	16	9	4	36	53	22	24,8	70	1	3/8" x 6,65	27	0,750					
																				120	2	1/2" x 8,51	21	0,800
LC 85	08085000	08085050	08085020	08085030	85	52	15	16	11	4	45	59	25	28,3	130	1	3/8" x 6,65	38	1,470					
																				240	2	1/2" x 8,51	25	1,480
LC 95	08095000	08095050	08095020	08095030	95	60	15	17	11	4	52	67	35	38,3	190	1	1/2" x 8,51	30	2,160					
																				340	2	5/8" x 10,16	25	2,170
LC 120	08120000	08120050	08120020	08120030	120	73	20	19	16	4	64	78	45	48,8	350	1	1/2" x 8,51	38	4,000					
																				650	2	5/8" x 10,16	32	4,000
LC 140	08140000	08140050	08140020	08140030	140	90	20	22	17	4	85	86,5	60	64,4	650	1	3/4" x 12,07	35	5,900					
																				1200	2	1" x 15,88	21	6,000
LC 170	08170000	08170050	08170020	08170030	170	100	28	25,5	18,5	4,5	90	94	65	69,4	1000	1	3/4" x 12,07	35	9,200					
																				1800	2	1" x 15,88	25	9,400

Pay attention. You are strongly advised to use the torque limiters of the series LC Cleaning, checking carefully that products or oily liquids in general do not reach in any way the friction materials in order to not cause a sudden and inevitable performance degradation. Adjust the guide bush according to their needs. The clutch plates are constituted by a structure that is absolutely free of asbestos.



CAD drawings available on our site
www.chiaravalli.com

Quantity, availability and prices
on B2B Chiaravalli



- LC Torque limiter connected to the coaxial pinion hub through a double chain.
- Easy adjustment of desired torque through lock nut.
- The two friction elements dished clutch are burnished.

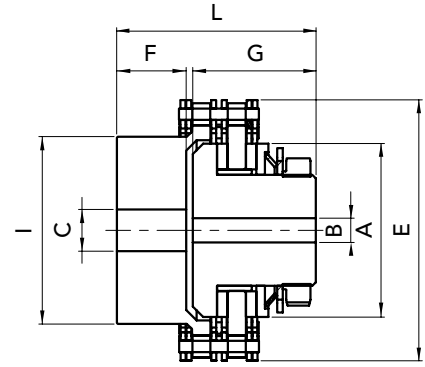
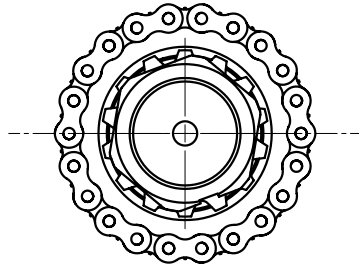

TORQUE LIMITERS WITH CHAIN COUPLING LCG

TYPE	PART NUMBER	max. torque	N° springs	A	B	B max	C max	C max	E	F	G	I	L	DIS. mm	ang.	chain pitch	Z teeth	weight Kg
LCG 50	08050000	30	1	50	7	20	12	30	75,19	20	35	45	57	0,20	30°	3/8 X 7/32"	22	1,000
		55	2															1,005
LCG 65	08065000	70	1	65	10	22	16	35	97,03	33	50	65	85	0,25	30°	1/2" X 5/16"	21	2,500
		120	2															2,550
LCG 85	08085000	130	1	85	15	25	20	45	121,25	36	55	85	94	0,30	30°	5/8" X 3/8"	21	4,300
		240	2															4,300
LCG 95	08095000	190	1	95	15	35	20	55	131,88	38	67	95	108	0,35	30°	3/4" X 7/16"	19	6,000
		340	2															6,010
LCG 120	08120000	350	1	120	20	45	20	60	168,13	47	78	120	128	0,35	30°	3/4" X 7/16"	25	11,000
		650	2															11,100
LCG 140	08140000	650	1	140	20	60	30	65	191,51	54	86	130	145	0,40	30°	1" X 17 mm	21	18,000
		1200	2															18,100
LCG 170	08170000	1000	1	170	28	65	30	75	223,74	84	95	130	184	0,50	30°	1" X 17 mm	25	27,000
		1800	2															27,200





- Suitable to connect two shafts in axis
- With hardened sprockets
- Provided with full cover, seals and O-ring for the protection from external contamination and also for an eventual lubrication of the coupling with grease.

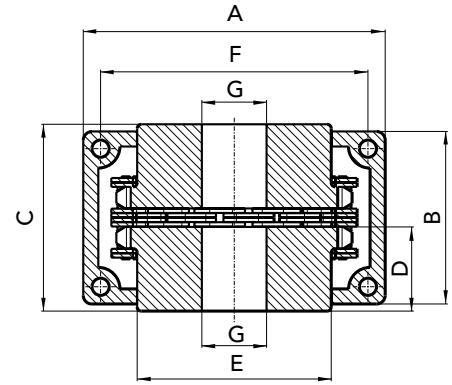
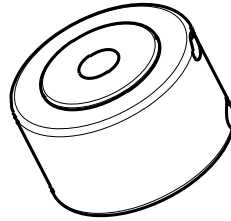

TYPE	PART NUMBER	CHAIN PITCH	A	B	C	D	E	G	G Max	Nm	Weight Kg.
KC 3012	KC3012	ASA 35-2	69	63	65	29,5	27,2	12	16	150	0,50
KC 4012	KC4012	ASA 40-2	77	72	79,4	36	36	12	22	210	1,00
KC 4014	KC4014	ASA 40-2	84	75	79,4	36	45	12	28	300	1,40
KC 4016	KC4016	ASA 40-2	92	72	87,4	40	54,5	13,5	32	380	1,80
KC 5014	KC5014	ASA 50-2	101	85	99,7	45	56	14,5	35	550	2,50
KC 5016	KC5016	ASA 50-2	110	87	99,7	45	64	14,5	40	725	3,20
KC 5018	KC5018	ASA 50-2	122	85	99,7	45	73,5	16	45	925	4,00
KC 6018	KC6018	ASA 60-2	147	105	123,5	56	89,5	20	55	1750	7,20
KC 6020	KC6020	ASA 60-2	158	105	123,5	56	102,5	20	60	2050	9,50
KC 6022	KC6022	ASA 60-2	168	117	123,5	56	115	20	75	2400	11,3
KC 8018	KC8018	ASA 80-2	190	129	141,2	63	115	20	75	3800	14,7
KC 8020	KC8020	ASA 80-2	210	137	145,2	65	125	20	80	4700	18,2
KC 8022	KC8022	ASA 80-2	226	137	157,2	71	142	20	90	5500	23,3
KC 10020	KC10020	ASA 100-2	281	153	178,8	80	162	25	110	8700	36,0
KC 12018	KC12018	ASA 120-2	307	181	202,7	90	173	35	120	13250	49,0
KC 12022	KC12022	ASA 120-2	357	181	222,7	100	213	35	150	17800	77,0



CAD drawings available on our site
www.chiaravalli.com

Quantity, availability and prices
 on B2B Chiaravalli



COLLARS and WASHERS

HEAVY TURNED WASHERS	page 4
TURNED TAPER WASHERS	5
TURNED WASHERS FOR SWIVEL HEADS	5
COLLARS IN COMPLIANCE WITH DIN 705	6
CLAMPING COLLARS FORM C-AB	7
CLAMPING COLLARS WITH OPEN RING	8



CLAMPING COLLARS

CLAMPING COLLARS

PHOSPHATED

GALVANISED

INOX

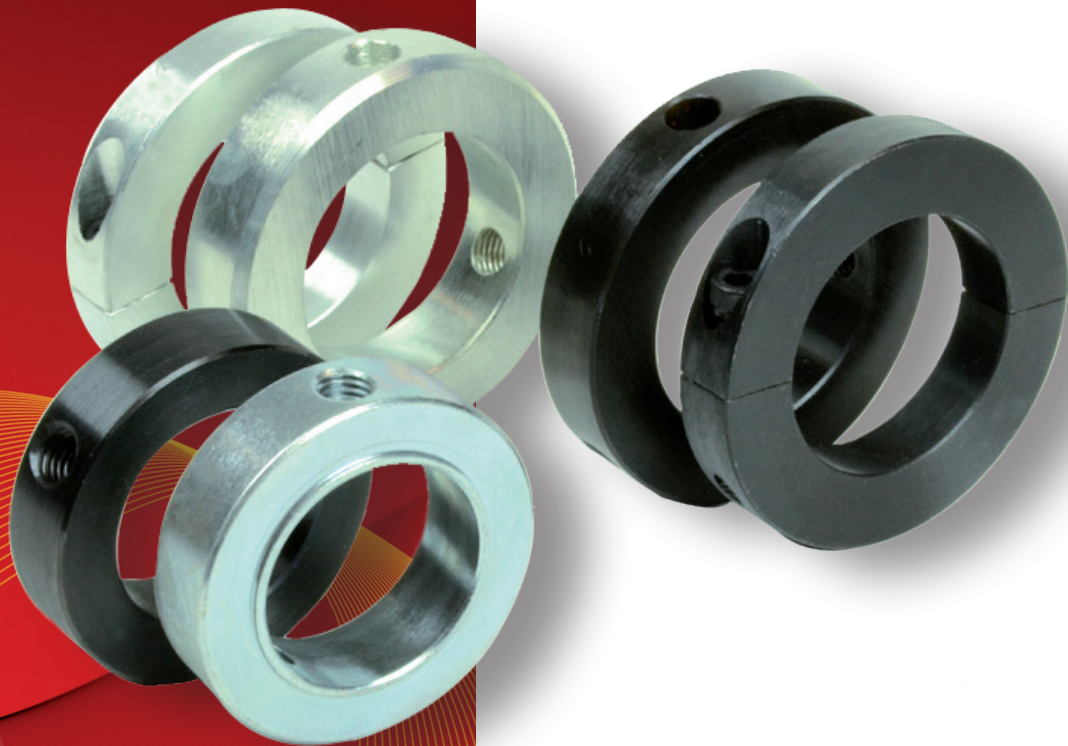

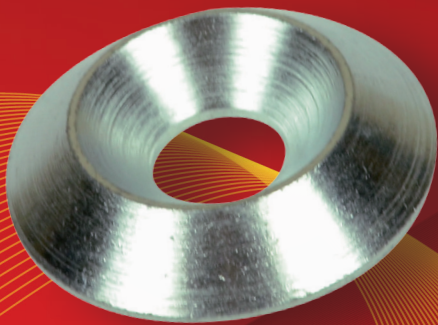
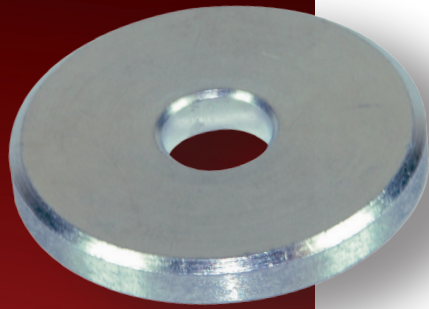

TURNED WASHERS
PHOSPHATED
GALVANISED



C-RGS

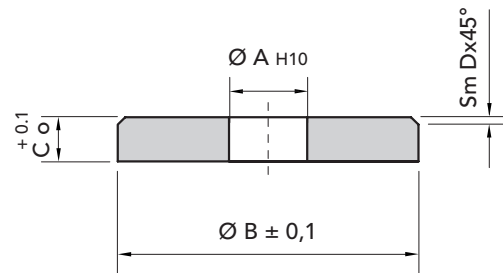

TYPE	PHOSPHATED PART NUMBER	GALVANISED PART NUMBER	Ø A	Ø B	C	D	PACKAGES FROM	WEIGHT PACKAGE kg
C-RGS 3-10	26100310	26200310	3,2	10	2	0,5	50	0,10
C-RGS 4-10	26100410	26200310	4,2	10	2	0,5	50	0,10
C-RGS 4-15	26100415	26200415	4,2	15	3	0,5	50	0,15
C-RGS 5-15	26100515	26200515	5,2	15	3	0,5	50	0,15
C-RGS 5-20	26100520	26200520	5,2	20	3	0,5	50	0,45
C-RGS 5-25	26100525	26200525	5,2	25	4	1	50	0,70
C-RGS 5-30	26100530	26200530	5,2	30	4	1	50	1,35
C-RGS 6-15	26100615	26200615	6,2	15	3	0,5	50	0,12
C-RGS 6-20	26100620	26200620	6,2	20	3	0,5	50	0,40
C-RGS 6-25	26100625	26200625	6,2	25	4	1	50	0,80
C-RGS 6-30	26100630	26200630	6,2	30	4	1	50	1,05
C-RGS 6-35	26100635	26200635	6,2	35	5	1	50	1,85
C-RGS 6-40	26100640	26200640	6,5	40	5	1	50	2,35
C-RGS 8-20	26100820	26200820	8,5	20	4	0,5	25	0,35
C-RGS 8-25	26100825	26200825	8,5	25	4	1	25	0,70
C-RGS 8-30	26100830	26200830	8,5	30	4	1	25	1,00
C-RGS 8-35	26100835	26200835	8,5	35	5	1	25	1,80
C-RGS 8-40	26100840	26200840	8,5	40	5	1	25	2,30
C-RGS 8-45	26100845	26200845	8,5	45	5	2	25	2,90
C-RGS 8-50	26100850	26200850	8,5	50	6	2	25	4,15
C-RGS 10-25	26101025	26201025	10,5	25	4	1	25	2,00
C-RGS 10-35	26101035	26201035	10,5	35	5	1	25	1,60
C-RGS 10-40	26101040	26201040	10,5	40	5	1	25	2,25
C-RGS 10-45	26101045	26201045	10,5	45	5	2	25	2,65
C-RGS 10-50	26101050	26201050	10,5	50	6	2	25	4,10
C-RGS 12-50	26101250	26201250	12,5	50	6	2	25	4,60

MATERIAL **C 45 UNI 7845**
PHOSPHATED
GALVANISED

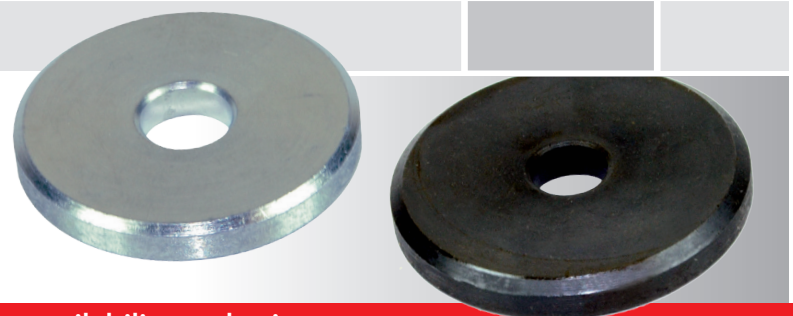

CAD drawings available on our site
www.chiaravalli.com

Quantity, availability and prices
 on B2B Chiaravalli



TURNED TAPER WASHERS

C-RC

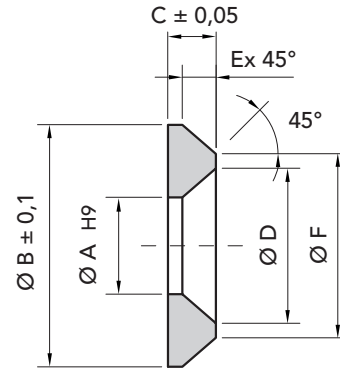

TYPE	PHOSPHATED P. NUMBER	GALVANISED P. NUMBER	Ø A	Ø B	C	Ø D	E	Ø F	PACKAGES	WEIGHT
									FROM	PACKAGE
C-RC 4	26300004	26400004	4,1	13	3	8	2,1x45°	8,8	50	0,12
C-RC 5	26300005	26400005	5,2	16	3,5	10	2,6x45°	10,8	50	0,15
C-RC 6	26300006	26400006	6,5	18	3,5	12	2,1x45°	13,8	50	0,24
C-RC 8	26300008	26400008	8,5	25	5	16,5	3,5x45°	18	50	0,36
C-RC 10	26300010	26400010	10,5	33	7	20,5	6x45°	21	50	0,75
C-RC 12	26300012	26400012	12,5	40	8	24,5	7x45°	26	50	1,50



TURNED TAPER WASHERS and TURNED WASHERS FOR SWIVEL HEADS



TURNED WASHERS FOR SWIVEL HEADS

C-RS

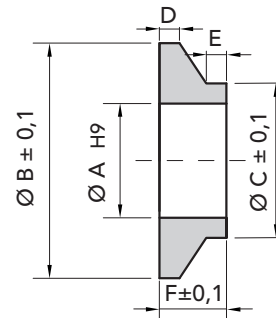

TYPE	PHOSPHATED P. NUMBER	GALVANISED P. NUMBER	Ø A	Ø B	C	Ø D	E	Ø F	PACKAGES	WEIGHT
									FROM	PACKAGE
C-RS 6	26500006	26600006	6,5	15	9	1,5	1	4	50	0,15
C-RS 8	26500008	26600008	8,5	22	12	1,5	2	6,5	50	0,27
C-RS 10	26500010	26600010	10,5	22	14	1,5	3	6,5	50	0,40



MATERIAL C 45 UNI 7845
PHOSPHATED
GALVANISED

CAD drawings available on our site
www.chiaravalli.com

Quantity, availability and prices
on B2B Chiaravalli



C-ABU

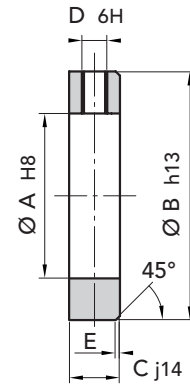
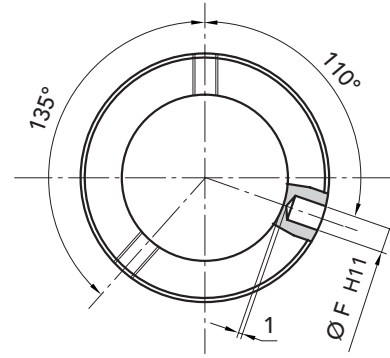

TYPE	PHOSPHATED P. NUMBER	GALVANISED P. NUMBER	INOX P. NUMBER	Ø A	Ø B	C	Ø D	E	Ø F	PACKAGES	PACKAGES	WEIGHT PACKAGE
										INOX FROM	PHOSP.-GALV. FROM	
C-ABU 6	27100006	27200006	27700006	6	12	8	M4	0,8	1,5	10	25	0,40
C-ABU 8	27100008	27200008	27700008	8	16	8	M4	0,8	2	10	25	0,80
C-ABU 10	27100010	27200010	27700010	10	20	10	M5	1	3	10	25	1,50
C-ABU 12	27100012	27200012	27700012	12	22	12	M6	1,2	4	10	25	2,00
C-ABU 14	27100014	27200014	-	14	25	12	M6	1,2	4	-	25	2,70
C-ABU 15	27100015	27200015	27700015	15	25	12	M6	1,2	4	5	20	2,50
C-ABU 16	27100016	27200016	27700016	16	28	12	M6	1,2	4	5	20	3,50
C-ABU 17	27100017	27200017	27700017	17	28	12	M6	1,2	4	5	20	3,00
C-ABU 18	27100018	27200018	-	18	32	14	M6	1,4	5	-	20	5,40
C-ABU 20	27100020	27200020	27700020	20	32	14	M6	1,4	5	5	20	4,80
C-ABU 25	27100025	27200025	27700025	25	40	16	M8	1,6	6	5	20	4,25
C-ABU 30	27100030	27200030	27700030	30	45	16	M8	1,6	6	2	10	5,00
C-ABU 35	27100035	27200035	27700035	35	56	16	M8	1,6	8	2	10	8,60
C-ABU 40	27100040	27200040	27700040	40	63	18	M10	1,8	8	2	10	12,00
C-ABU 45	27100045	27200045	-	45	70	18	M10	1,8	8	-	10	13,50
C-ABU 50	27100050	27200050	27700050	50	80	18	M10	1,8	10	-	-	22,00
C-ABU 60	27100060	27200060	-	60	90	20	M10	2	10	-	-	26,40
C-ABU 70	27100070	27200070	-	70	100	20	M10	2	10	-	-	28,75



MATERIAL C 45 UNI 7845
PHOSPHATED
GALVANISED
INOX AISI 304

CAD drawings available on our site
www.chiaravalli.com

Quantity, availability and prices
on B2B Chiaravalli



CLAMPING COLLARS FORM C-AB

C-AB

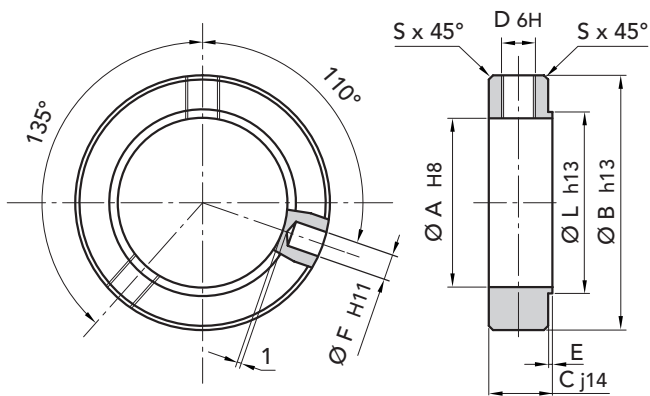

CLAMPING COLLARS FORM C-AB

TYPE	PHOSPHATED P. NUMBER	GALVANISED P. NUMBER									PACKAGES	WEIGHT
			Ø A	Ø B	C	Ø D	E	Ø F	Ø L	S	FROM	PACKAGE
C-AB 6	27300006	27400006	6	12	8	M4	0,6	1,5	8	0,3	30	0,06
C-AB 8	27300008	27400008	8	16	8	M4	0,8	2	10	0,3	30	0,24
C-AB 10	27300010	27400010	10	20	10	M5	0,8	3	13	0,3	30	0,36
C-AB 12	27300012	27400012	12	22	12	M5	0,8	4	15	0,5	30	0,42
C-AB 15	27300015	27400015	15	25	12	M6	1	4	18	0,6	25	0,63
C-AB 17	27300017	27400017	17	28	12	M6	1	4	20	0,6	25	0,72
C-AB 20	27300020	27400020	20	32	14	M6	1	5	24	0,8	25	1,44
C-AB 25	27300025	27400025	25	40	16	M6	1	6	29	0,8	25	2,61
C-AB 30	27300030	27400030	30	45	16	M8	1,2	6	34	1	15	2,10
C-AB 35	27300035	27400035	35	56	16	M8	1,2	8	39	1	15	4,92
C-AB 40	27300040	27400040	40	63	18	M10	1,2	8	44	1	15	7,50



MATERIAL C 45 UNI 7845
PHOSPHATED
GALVANISED

CAD drawings available on our site
www.chiaravalli.com

Quantity, availability and prices
on B2B Chiaravalli



PILLOW BLOCKS FSB[®] BRAND

MONOBLOCK PILLOW BLOCKS RCM[®] BRAND

CAST IRON PILLOW BLOCKS

SERIES: UCP 200	page 4
UCF 200	5
UCFL 200	6
UCFA 200	7
UCT 200	8
UCFC 200	9
UCPA 200	10

PRESSED STEEL HOUSING PILLOW BLOCKS

SERIES: PP 200	11
PF 200	12
PFL 200	13

THERMOPLASTIC PILLOW BLOCKS

SERIES: P 200	14
F 200	15
FL 200	16

BEARINGS

SERIES: UC 200	18
UK 200	19
SB RE-LUBRICATING 200	20
SA RE-LUBRICATING 200	21

INOX BEARINGS

SERIES: SUC 200	23
SSSB RE-LUBRICATING 200	24

BUSHES SERIES H23... AND COVER FOR PILLOW BLOCKS

SEALS	26
-------	----

PILLOW BLOCKS

RCM SERIES	page 28
------------	---------

Nominal torque and power rating	31
Diagram for the choice of RCM pillow blocks	32

RCM SERIES AS standard shaft	34
---------------------------------	----

RCM SERIES AL long shaft	36
-----------------------------	----

RCM SERIES RCM-AL for cooling fan	38
--------------------------------------	----

NON-ROTATING GROUP	39
--------------------	----



CHIARAVALLI GROUP BRAND **FSB®**
CAST IRON, PRESSED STEEL HOUSING AND THERMOPLASTIC **PILLOW BLOCKS**

SERIES CAST IRON, PRESSED STEEL HOUSING AND THERMOPLASTIC **PILLOW BLOCKS BRAND FSB®**





CHIARAVALLI GROUP BRAND **FSB®**
 CAST IRON, PRESSED STEEL HOUSING AND THERMOPLASTIC PILLOW BLOCKS



UCP 200



UCFC 200



P 200

THERMOPLASTIC



UCF 200

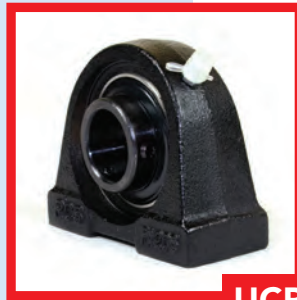

UCPA 200



F 200

THERMOPLASTIC



UCFL 200



PP 200



FL 200

THERMOPLASTIC



UCFA 200



PF 200



SA 200

SB 200



SSSB 200

SUC 200



UCT 200



PFL 200



**compass
H23**

UC 200

UK 200

UCP 200

FROM 202 TO 211
 SUITABLE FOR COVER ASSEMBLY

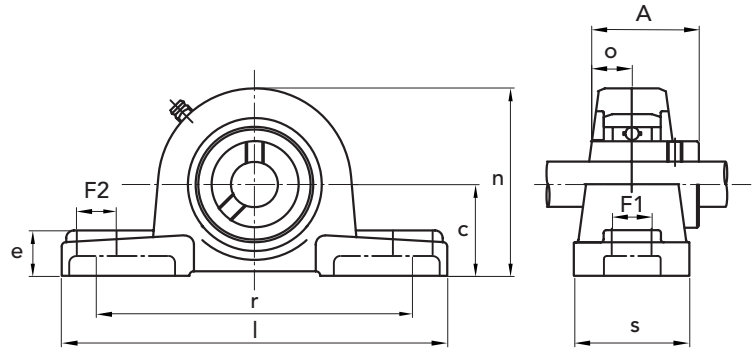

UCP	PART NUMBER	shaft hole Ø mm	DIMENSIONS mm										bearing No.	bolt dimensions mm	housing No.	weight kg
			c	l	r	s	F1	F2	e	n	A	o				
202	93100202	15	30,2	127	95	38	13	16	14	62	31	12,7	UC 202	M10	P202	0,63
203	93100203	17	30,2	127	95	38	13	16	14	62	31	12,7	UC 203	M10	P203	0,62
204	93100204	20	33,3	127	95	38	13	16	14	65	31	12,7	UC 204	M10	P204	0,70
205	93100205	25	36,5	140	105	38	13	16	15	71	34	14,3	UC 205	M10	P205	0,81
206	93100206	30	42,9	165	121	48	17	20	17	83	38,1	15,9	UC 206	M14	P206	1,30
207	93100207	35	47,6	167	127	48	17	20	18	93	42,9	17,5	UC 207	M14	P207	1,60
208	93100208	40	49,2	184	137	54	17	20	18	98	49,2	19	UC 208	M14	P208	2,00
209	93100209	45	54	190	146	54	17	20	20	106	49,2	19	UC 209	M14	P209	2,30
210	93100210	50	57,2	206	159	60	20	23	21	114	51,6	19	UC 210	M16	P210	2,90
211	93100211	55	63,5	219	171	60	20	23	23	126	55,6	22,2	UC 211	M16	P211	3,70
212	93100212	60	69,8	241	184	70	20	23	25	138	65,1	25,4	UC 212	M16	P212	4,90
213	93100213	65	76,2	265	203	70	25	28	27	151	65,1	25,4	UC 213	M20	P213	5,90
214	93100214	70	79,4	266	210	72	25	28	27	157	74,6	30,2	UC 214	M20	P214	6,60
215	93100215	75	82,6	275	217	74	25	28	28	163	77,8	33,3	UC 215	M20	P215	7,30
216	93100216	80	88,9	292	232	78	25	28	30	175	82,6	33,3	UC 216	M20	P216	10,0
217	93100217	85	95,2	310	247	83	25	28	32	187	85,7	34,1	UC 217	M20	P217	12,2
218	93100218	90	101,6	327	262	88	27	30	33	200	96	39,7	UC 218	M22	P218	14,7

CAD drawings available on our site
www.chiaravalli.com

Quantity, availability and prices
 on B2B Chiaravalli

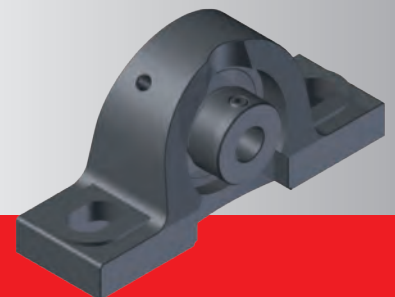



UCF 200

FROM 202 TO 211
 SUITABLE FOR COVER ASSEMBLY

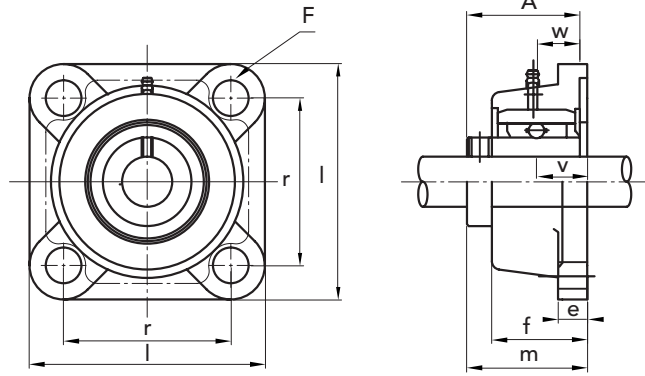

CAST IRON PILLOW BLOCKS SERIES UCF 200

UCF	PART NUMBER	shaft hole Ø mm	DIMENSIONS mm									bolt			weight kg	
			l	r	v	e	f	F	m	A	w	bearing No.	dimension mm	housing No.		
202	93200202	15	86	64	15	11	25,5	12	33,3	31	12,7	UC 202	M10	P202	0,62	
203	93200203	17	86	64	15	11	25,5	12	33,3	31	12,7	UC 203	M10	P203	0,61	
204	93200204	20	86	64	15	11	25,5	12	33,3	31	12,7	UC 204	M10	P204	0,61	
205	93200205	25	95	70	16	13	27	12	35,7	34	14,3	UC 205	M10	P205	0,80	
206	93200206	30	108	83	18	13	31	12	40,2	38,1	15,9	UC 206	M10	P206	1,00	
207	93200207	35	117	92	19	15	34	14	44,4	42,9	17,5	UC 207	M12	P207	1,40	
208	93200208	40	130	102	21	15	36	16	51,2	49,2	19	UC 208	M14	P208	1,80	
209	93200209	45	137	105	22	16	38	16	52,2	49,2	19	UC 209	M14	P209	2,20	
210	93200210	50	143	111	22	16	40	16	54,6	51,6	19	UC 210	M14	P210	2,40	
211	93200211	55	162	130	25	18	43	19	58,4	55,6	22,2	UC 211	M16	P211	3,50	
212	93200212	60	175	143	29	18	48	19	68,7	65,1	25,4	UC 212	M16	P212	4,20	
213	93200213	65	187	149	30	22	50	19	69,7	65,1	25,4	UC 213	M16	P213	5,30	
214	93200214	70	193	152	31	22	54	19	75,4	74,6	30,2	UC 214	M16	P214	5,90	
215	93200215	75	200	159	34	22	56	19	78,5	77,8	33,3	UC 215	M16	P215	6,30	
216	93200216	80	208	165	34	22	58	23	83,3	82,6	33,3	UC 216	M20	P216	7,80	
217	93200217	85	220	175	36	24	63	23	87,6	85,7	34,1	UC 217	M20	P217	9,30	
218	93200218	90	235	187	40	24	68	23	96,3	96	39,7	UC 218	M20	P218	11,3	

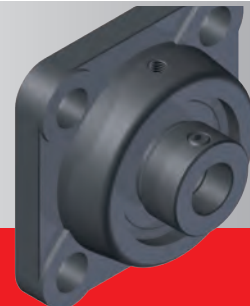

UCFL 200

FROM 202 TO 211
 SUITABLE FOR COVER ASSEMBLY

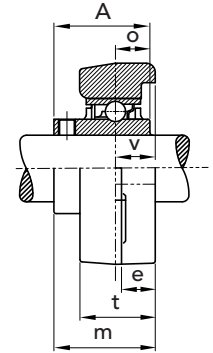
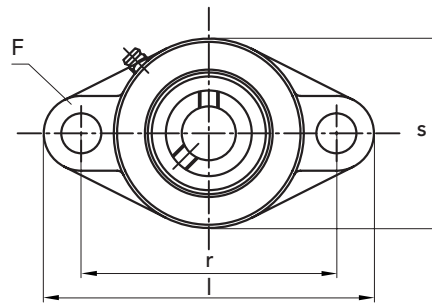

UCFL	PART NUMBER	shaft hole Ø mm	DIMENSIONS mm										bolt			weight kg	
			l	r	v	e	t	F	s	m	A	o	bearing No.	dimensions mm	housing No.		
202	93300202	15	113	90	15	11	25,5	12	60	33,3	31	12,7	UC 202	M10	FL202	0,47	
203	93300203	17	113	90	15	11	25,5	12	60	33,3	31	12,7	UC 203	M10	FL203	0,45	
204	93300204	20	113	90	15	11	25,5	12	60	33,3	31	12,7	UC 204	M10	FL204	0,43	
205	93300205	25	130	99	16	13	27	16	68	35,7	34	14,3	UC 205	M14	FL205	0,61	
206	93300206	30	148	117	18	13	31	16	80	40,2	38,1	15,9	UC 206	M14	FL206	0,86	
207	93300207	35	161	130	19	15	34	16	90	44,4	42,9	17,5	UC 207	M14	FL207	1,20	
208	93300208	40	175	144	21	15	36	16	100	51,2	49,2	19	UC 208	M14	FL208	1,48	
209	93300209	45	188	148	22	16	38	19	108	52,2	49,2	19	UC 209	M16	FL209	1,84	
210	93300210	50	197	157	22	16	40	19	115	54,6	51,6	19	UC 210	M16	FL210	2,14	
211	93300211	55	224	184	25	18	43	19	130	58,4	55,6	22,2	UC 211	M16	FL211	2,98	
212	93300212	60	250	202	29	18	48	23	140	68,7	65,1	25,4	UC 212	M20	FL212	3,90	
213	93300213	65	258	210	30	22	50	23	155	69,7	65,1	25,4	UC 213	M20	FL213	4,77	
214	93300214	70	265	216	31	22	54	23	160	75,4	74,6	30,2	UC 214	M20	FL214	5,22	
215	93300215	75	275	225	34	22	56	23	165	78,5	77,8	33,3	UC 215	M20	FL215	5,66	
216	93300216	80	290	233	34	22	58	25	180	83,3	82,6	33,3	UC 216	M22	FL216	7,13	

CAD drawings available on our site
www.chiaravalli.com

Quantity, availability and prices
 on B2B Chiaravalli

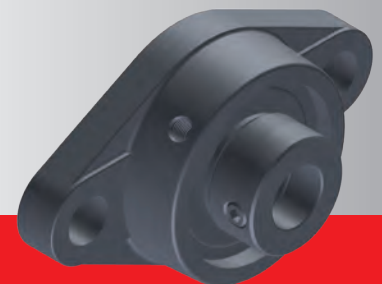



UCFA 200

FROM 202 TO 211
 SUITABLE FOR COVER ASSEMBLY

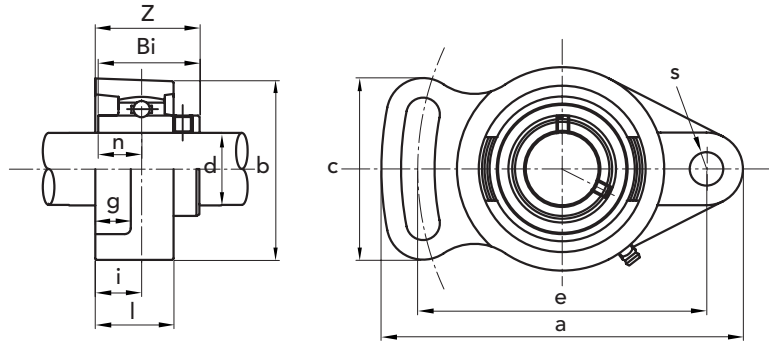

CAST IRON PILLOW BLOCKS SERIES UCFA 200

UCFA	PART NUMBER	shaft hole Ø mm	DIMENSIONS mm											bolt			weight kg
			a	e	i	g	l	s	b	z	c	Bi	n	bearing No.	dimension mm	housing No.	
202	93310202	15	98	78	15	11	25,5	10	60	33,3	50	31,1	12,7	UC 202	M8	FA202	0,47
203	93310203	17	98	78	15	11	25,5	10	60	33,3	50	31,1	12,7	UC 203	M8	FA203	0,47
204	93310204	20	98	78	15	11	25,5	10	60	33,3	50	31,1	12,7	UC 204	M8	FA204	0,47
205	93310205	25	124	98	16	13	27	12	70	35,7	65	34	14,3	UC 205	M10	FA205	0,68
206	93310206	30	141	117	18	13	31	12	83	40,2	72	38,1	15,9	UC 206	M10	FA206	1,00
207	93310207	35	155	130	19	14	34	14	96	44,4	82	42,9	17,5	UC 207	M12	FA207	1,50
208	93310208	40	171	144	21	14	38	14	105	51,2	87	49,2	19	UC 208	M12	FA208	1,90



UCT 200

FROM 202 TO 211
 SUITABLE FOR COVER ASSEMBLY

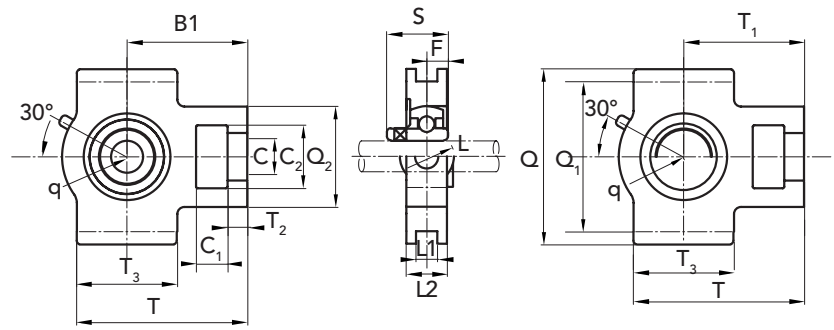

UCT	PART NUMBER	shaft hole Ø mm	DIMENSIONS mm																	weight kg
			C ₁	T ₂	Q ₂	C ₂	C	T ₃	L ₁	Q ₁	Q	T	L ₂	L	q	T ₁	S	F		
202	93400202	15	16	12	51	32	19	51	12	76	89	94	21	32	33	61	31	12,7	0,80	
203	93400203	17	16	12	51	32	19	51	12	76	89	94	21	32	33	61	31	12,7	0,80	
204	93400204	20	16	12	51	32	19	51	12	76	89	94	21	32	33	61	31	12,7	0,80	
205	93400205	25	16	12	51	32	19	51	12	76	89	97	24	32	35	62	34	14,3	0,80	
206	93400206	30	16	12	56	37	22	57	12	89	102	113	28	37	43	70	38,1	15,9	1,15	
207	93400207	35	16	15	64	37	22	64	12	89	102	129	30	37	51	78	42,9	17,5	1,15	
208	93400208	40	19	18	83	49	29	83	16	102	114	144	33	49	56	88	49,2	19	1,15	
209	93400209	45	19	18	83	49	29	83	16	102	117	145	35	49	57	88	49,2	19	1,28	
210	93400210	50	19	18	83	49	29	86	16	102	117	151	37	49	59	92	51,6	19	1,28	
211	93400211	55	25	21	102	64	35	95	22	130	146	171	38	64	65	106	55,6	22,2	1,28	
212	93400212	60	32	21	102	64	35	102	22	130	146	194	42	64	75	119	65,1	25,4	4,58	
213	93400213	65	32	21	111	70	41	121	26	151	167	224	44	70	80	137	65,1	25,4	6,65	
214	93400214	70	32	21	111	70	41	121	26	151	167	224	46	70	80	137	74,6	30,2	6,80	

CAD drawings available on our site
www.chiaravalli.com

Quantity, availability and prices
 on B2B Chiaravalli

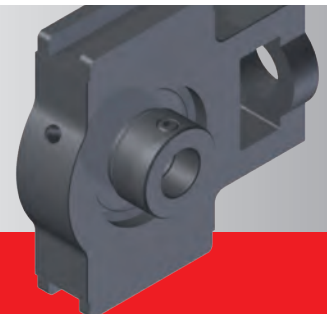



UCFC 200

FROM 202 TO 211
SUITABLE FOR COVER ASSEMBLY

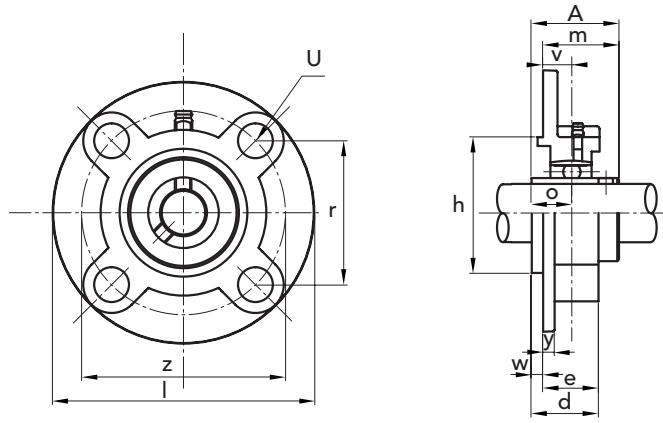

CAST IRON PILLOW BLOCKS SERIES UCFC 200

UCFC	PART NUMBER	shaft hole Ø mm	DIMENSIONS mm													bearing No.	dimensions housing mm	housing No.	weight kg
			l	z	r	v	d	U	y	w	e	h	m	A	o				
202	93500202	15	100	78	55,1	10	25,5	12	5	7	20,5	62	28,3	31	12,7	UC 202	M10	FC202	0,76
203	93500203	17	100	78	55,1	10	25,5	12	5	7	20,5	62	28,3	31	12,7	UC 203	M10	FC203	0,76
204	93500204	20	100	78	55,1	10	25,5	12	5	7	20,5	62	28,3	31	12,7	UC 204	M10	FC204	0,76
205	93500205	25	115	90	63,6	10	27	12	6	7	21	70	29,7	34	14,3	UC 205	M10	FC205	0,96
206	93500206	30	125	100	70,7	10	31	12	8	8	23	80	32,2	38,1	15,9	UC 206	M10	FC206	1,30
207	93500207	35	135	110	77,8	11	34	14	8	9	26	90	36,4	42,9	17,5	UC 207	M12	FC207	1,70
208	93500208	40	145	120	84,8	11	36	14	10	9	26	100	41,2	49,2	19	UC 208	M12	FC208	2,00
209	93500209	45	160	132	93,3	10	38	16	12	14	26	105	40,2	49,2	19	UC 209	M14	FC209	2,70
210	93500210	50	165	138	97,6	10	40	16	12	14	28	110	42,6	51,6	19	UC 210	M14	FC210	2,90
211	93500211	55	185	150	106,1	13	43	19	12	15	31	125	46,4	55,6	22,2	UC 211	M16	FC211	4,30
212	93500212	60	195	160	113,1	17	48	19	12	15	36	135	56,7	65,1	25,4	UC 212	M16	FC212	5,00
213	93500213	65	205	170	120,2	16	50	19	14	15	36	145	55,7	65,1	25,4	UC 213	M16	FC213	5,70
214	93500214	70	215	177	125,1	17	54	19	14	18	40	150	61,4	74,6	30,2	UC 214	M16	FC214	6,80

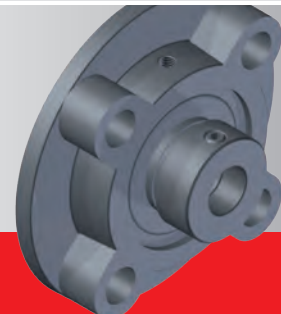

UCPA 200

FROM 202 TO 211
 SUITABLE FOR COVER ASSEMBLY

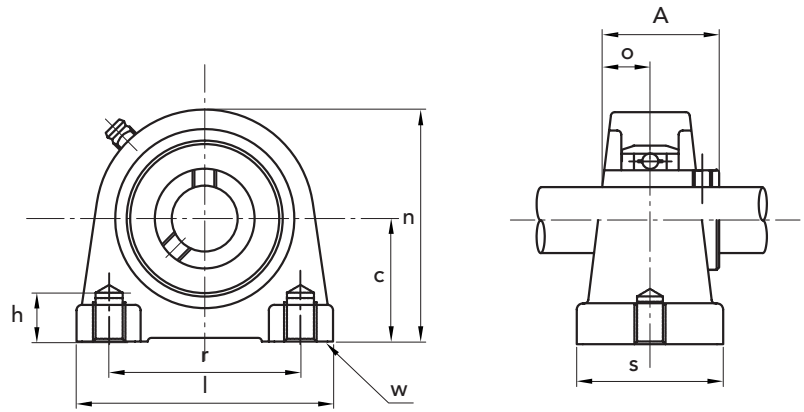

UCPA	PART NUMBER	shaft hole Ø mm	DIMENSIONS mm										bearing No.	housing No.	weight kg
			c	l	r	s	w	n	A	o	h				
202	93600202	15	30,2	76	52	40	M10x1,5	62	31	12,7	13	UC 202	PA202	0,63	
203	93600203	17	30,2	76	52	40	M10x1,5	62	31	12,7	13	UC 203	PA203	0,62	
204	93600204	20	30,2	76	52	40	M10x1,5	62	31	12,7	13	UC 204	PA204	0,64	
205	93600205	25	36,5	84	56	45	M10x1,5	72	34	14,3	15	UC 205	PA205	0,81	
206	93600206	30	42,9	94	66	50	M14x2	84	38,1	15,9	18	UC 206	PA206	1,20	
207	93600207	35	47,6	110	80	55	M14x2	95	42,9	17,5	20	UC 207	PA207	1,65	
208	93600208	40	49,2	116	84	58	M14x2	100	49,2	19	20	UC 208	PA208	2,00	
209	93600209	45	54,2	120	90	60	M14x2	108	49,2	19	25	UC 209	PA209	2,30	
210	93600210	50	57,2	130	94	64	M16x2	116	51,6	19	25	UC 210	PA210	2,90	
211	93600211	55	63,5	140	104	66	M16x2	125	55,6	22,2	25	UC 211	PA211	3,16	
212	93600212	60	69,9	150	114	68	M16x2	138	65,1	25,4	25	UC 212	PA212	4,15	
213	93600213	65	76,2	160	124	70	M16x2	150	65,1	25,4	25	UC 213	PA213	5,09	

CAD drawings available on our site
www.chiaravalli.com

Quantity, availability and prices
 on B2B Chiaravalli

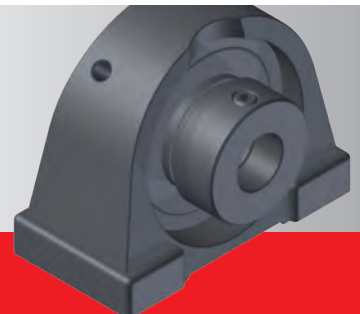



PP 200

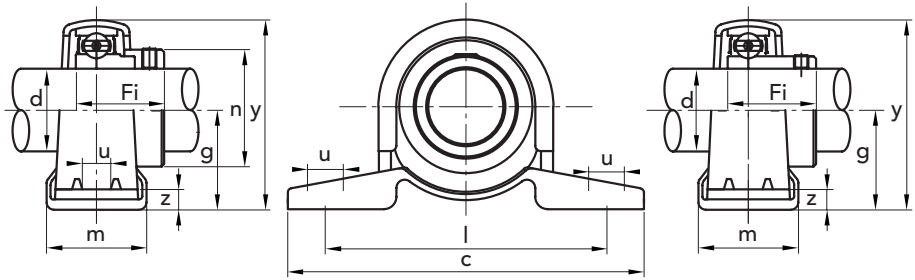

PRESSED STEEL HOUSING PILLOW BLOCKS SERIES PP 200

PP	PART NUMBER	shaft hole Ø mm	DIMENSIONS mm							bolt c mm	SAPP				SBPP			housing No.
			g	c	l	m	u	z	y		Fi	n	No.	kg	Fi	No.	Kg	
201	93700201	12	22,2	86	68	25	9,5	3	43,8	M8	28,6	28,6	SA201	0,19	22	SB201	0,16	PP201
202	93700202	15	22,2	86	68	25	9,5	3	43,8	M8	28,6	28,6	SA202	0,19	22	SB202	0,16	PP202
203	93700203	17	22,2	86	68	25	9,5	3	43,8	M8	28,6	28,6	SA203	0,19	22	SB203	0,16	PP203
204	93700204	20	25,4	98	76	32	9,5	3	50,5	M8	31	33,3	SA204	0,23	25	SB204	0,23	PP204
205	93700205	25	28,6	108	86	32	11,5	4	56,6	M10	31	38,1	SA205	0,32	27	SB205	0,28	PP205
206	93700206	30	33,3	117	95	38	11,5	4	66,3	M10	35,7	44,5	SA206	0,41	30	SB206	0,38	PP206
207	93700207	35	39,7	129	106	42	11,5	5	77,7	M10	38,9	55,6	SA207	0,50	32	SB207	0,47	PP207

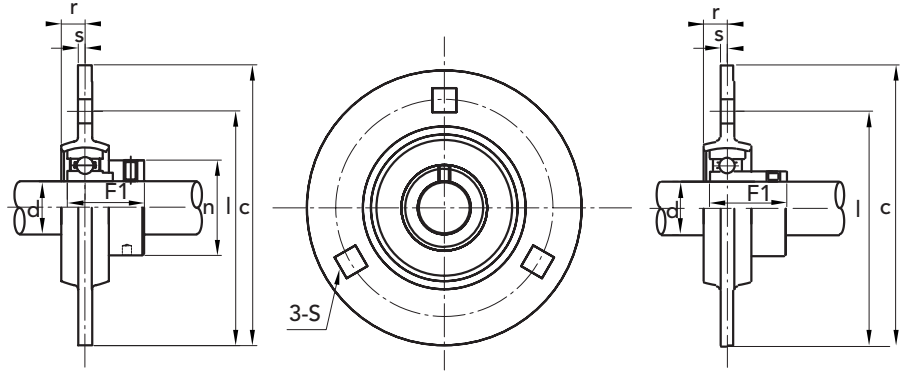

PF 200

SAPF
SBPF

PF	PART NUMBER	shaft hole Ø mm	DIMENSIONS mm					bolt dimensions mm	bearing weight			bearing weight housing				
			c	l	r	s	S		Fi	n	No.	kg	Fi	No.	Kg	No.
201	93800201	12	81	63,5	7	2	7,1	M6	28,6	28,6	SA201	0,30	22	SB201	0,27	PF201
202	93800202	15	81	63,5	7	2	7,1	M6	28,6	28,6	SA202	0,30	22	SB202	0,27	PF202
203	93800203	17	81	63,5	7	2	7,1	M6	28,6	28,6	SA203	0,30	22	SB203	0,27	PF203
204	93800204	20	90	71,5	8	2	9	M8	31	33,3	SA204	0,33	25	SB204	0,33	PF204
205	93800205	25	95	76	9	2	9	M8	31	38,1	SA205	0,42	27	SB205	0,38	PF205
206	93800206	30	113	90,5	9,5	2,6	11	M10	35,7	44,5	SA206	0,65	30	SB206	0,62	PF206
207	93800207	35	122	100	10	2,6	11	M10	38,9	55,6	SA207	0,90	32	SB207	0,82	PF207
208	93800208	40	148	119	11,5	3,5	13,5	M12	43,7	60,3	SA208	1,40	34	SB208	1,3	PF208
209	93800209	45	150	120,5	11,5	3,5	13,5	M12	43,7	63,5	SA209	1,50	41,2	SB209	1,5	PF209

CAD drawings available on our site
www.chiaravalli.com

Quantity, availability and prices
on B2B Chiaravalli





PFL 200

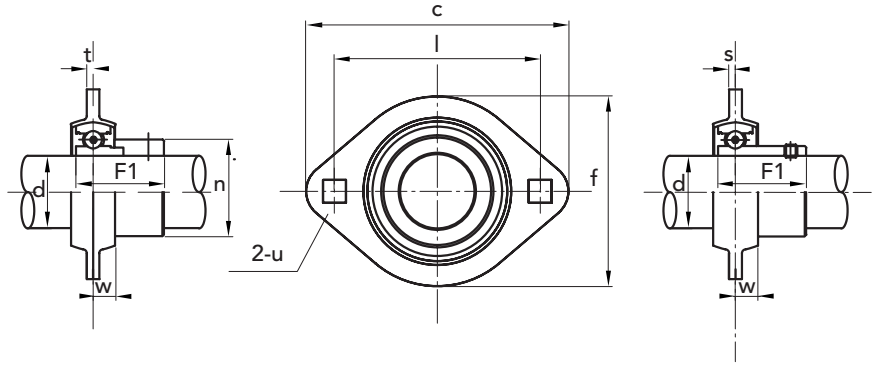

PRESSED STEEL HOUSING PILLOW BLOCKS SERIES PFL 200

PFL	PART NUMBER	shaft hole Ø mm	DIMENSIONS mm							bolt dimensions		SAPFL bearing weight			SBPFL bearing weight			housing No.
			c	l	w	f	s	u	mm	Fi	n	No.	kg	Fi	No.	Kg		
201	93900201	12	81	63,5	7	59	2	7,1	M6	28,6	28,6	SA201	0,22	22	SB201	0,19	PFL201	
202	93900202	15	81	63,5	7	59	2	7,1	M6	28,6	28,6	SA202	0,22	22	SB202	0,19	PFL202	
203	93900203	17	81	63,5	7	59	2	7,1	M6	28,6	28,6	SA203	0,22	22	SB203	0,19	PFL203	
204	93900204	20	90	71,5	8	67	2	9	M8	31	33,3	SA204	0,24	25	SB204	0,24	PFL204	
205	93900205	25	95	76	9	71	2	9	M8	31	38,1	SA205	0,32	27	SB205	0,28	PFL205	
206	93900206	30	113	90,5	9,5	84	2,6	11	M10	35,7	44,5	SA206	0,41	30	SB206	0,38	PFL206	
207	93900207	35	122	100	10	94	2,6	11	M10	38,9	55,6	SA207	0,50	32	SB207	0,42	PFL207	
208	93900208	40	148	119	11	106	3,5	13,5	M12	43,7	60,3	SA208	0,67	34	SB208	0,60	PFL208	

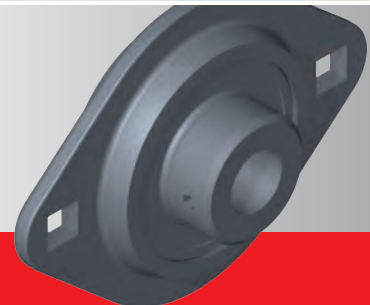

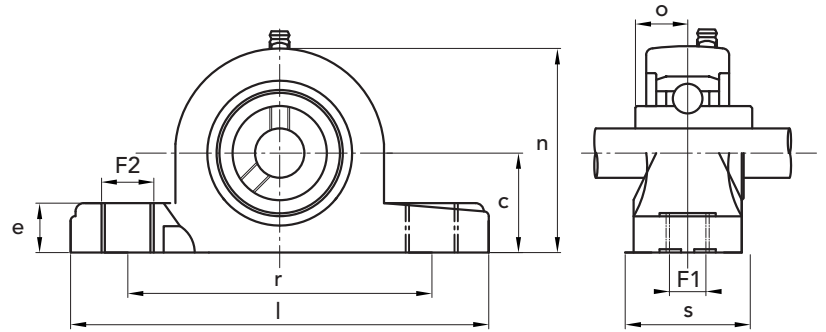
P 200

P	PART NUMBER	shaft hole Ø mm	DIMENSIONS mm									bearing mm	housing No.	weight kg
			c	l	r	s	F1	F2	e	n	o			
203	93191203	17	33,3	127	95	38	11	14	14,2	65,5	12,7	M10	P203	0,13
204	93191204	20	33,3	127	95	38	11	14	14,2	65,5	12,7	M10	P204	0,13
205	93191205	25	36,5	140,5	105	38	11	14	14,5	71	14,3	M10	P205	0,14
206	93191206	30	42,9	163	119	46	14	18	17,8	84	15,9	M12	P206	0,25
207	93191207	35	47,6	168	127	48	14	18	18	94,5	17,5	M12	P207	0,27
208	93191208	40	49,2	184	137	54	14	18	19,5	99	19	M12	P208	0,32
209	93191209	45	54	192	146	54	17	20	23	1,6	19	M16	P209	0,37
210	93191210	50	57,2	206	159	60	17	20	23	114	19	M16	P210	0,44

SUCP	PART NUMBER	shaft hole Ø mm	DIMENSIONS mm									bearing	housing No.	weight kg
			c	l	r	s	F1	F2	e	n	o			
205	93192205	25	36,5	140,5	105	38	11	14	14,5	71	14,3	SUC 205	P205	0,33
206	93192206	30	42,9	163	119	46	14	18	17,8	84	15,9	SUC 206	P206	0,56
207	93192207	35	47,6	168	127	48	14	18	18	94,5	17,5	SUC 207	P207	0,73
208	93192208	40	49,2	184	137	54	14	18	19,5	99	19	SUC 208	P208	0,93

CAD drawings available on our site
www.chiaravalli.com

Quantity, availability and prices
 on B2B Chiaravalli





F 200

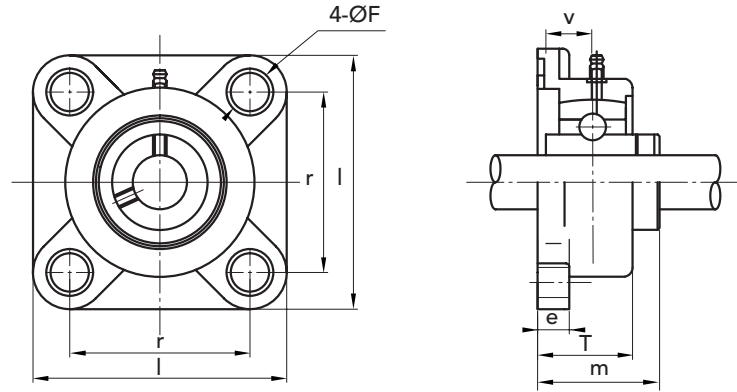

F	PART NUMBER	shaft hole Ø mm	DIMENSIONS mm							bearing mm	housing No.	weight kg
			l	r	e	T	F	m	v			
203	93291203	17	88	63,5	14,4	27,8	11	36,3	18	M10	F203	0,13
204	93291204	20	88	63,5	14,4	27,8	11	36,3	18	M10	F204	0,13
205	93291205	25	95	70	14	28	11	36,7	17	M10	F205	0,14
206	93291206	30	107	83	14,3	31,5	11	41,4	19,2	M10	F206	0,21
207	93291207	35	118	92	15,5	34,8	13	45,9	21,5	M12	F207	0,26
208	93291208	40	130	102	17	37,5	14	53,2	23	M16	F208	0,34
209	93291209	45	137	105	19	41	17	54,2	24	M16	F209	0,41
210	93291210	50	143	111	21	43	17	57,6	25	M16	F210	0,44

SUCFL	PART NUMBER	shaft hole Ø mm	DIMENSIONS mm							bearing	housing No.	weight kg
			l	r	e	T	F	m	v			
204	93292204	20	88	63,5	14,4	27,8	11	36,3	18	SUC 204	F204	0,28
205	93292205	25	95	70	14	28	11	36,7	17	SUC 205	F205	0,33
206	93292206	30	107	83	14,3	31,5	11	41,4	19,2	SUC 206	F206	0,52
208	93292208	40	130	102	17	37,5	14	53,2	23	SUC 208	F208	0,95L

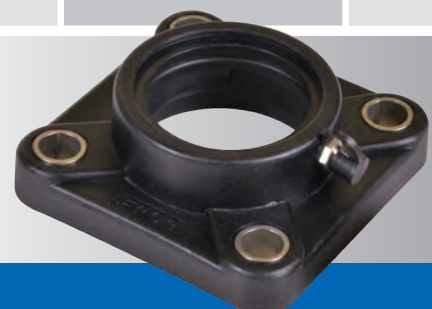

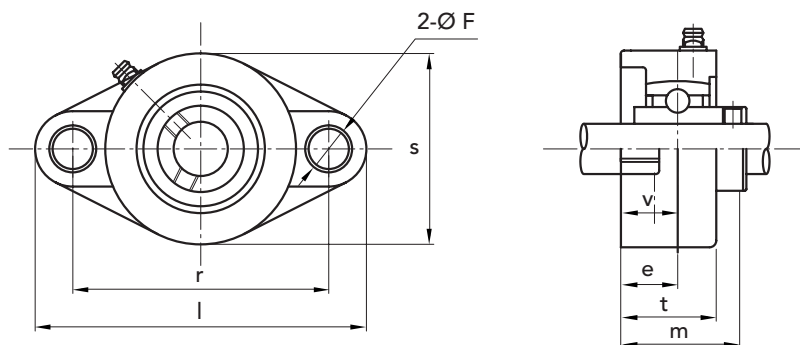
FL 200

FL	PART NUMBER	shaft hole Ø mm	DIMENSIONS mm								bearing mm	housing No.	weight kg
			l	r	s	e	t	F	m	v			
203	93391203	17	113	90	65	11,4	26,5	11	33,7	15,4	M10	FL203	0,09
204	93391204	20	113	90	65	11,4	26,5	11	33,7	15,4	M10	FL204	0,09
205	93391203	25	131	99	69,5	13,5	29,1	11	36,7	17	M10	FL205	0,11
206	93391206	30	148	117	80	13,3	30,5	11	41,2	19	M10	FL206	0,13
207	93391207	35	164	130	90	16,1	32,8	13	43,4	18	M10	FL207	0,17
208	93391208	40	176	144	100	20	37,5	14	51,7	21,5	M10	FL208	0,24

SUCFL	PART NUMBER	shaft hole Ø mm	DIMENSIONS mm								bearing	housing No.	weight kg
			l	r	s	e	t	F	m	v			
206	93392206	30	148	117	80	13,3	30,5	11	41,2	19	SUC 206	FL206	0,44
207	93392207	35	164	130	90	16,1	32,8	13	43,4	18	SUC 207	FL207	0,63
208	93392208	40	176	144	100	20	37,5	14	51,7	21,5	SUC 208	FL208	0,85

CAD drawings available on our site
www.chiaravalli.com

Quantity, availability and prices
 on B2B Chiaravalli





FSB thermoplastic pillow blocks are planned for particular applications in the food industry, in the chemical, pharmaceutical and photographic industry; as well as where there are corrosion problems.

Thanks to the qualities of resistance to the corrosion and antimagnetism, they support hard work conditions in all their applications.

Thermoplastic FSB pillow blocks are planned and built with fat approved for food industry. (Contact us for requiring specific use fat).

Thermoplastic FSB pillow blocks are built to reply to the exigencies of:

- Resistance to corrosion
- Exposition to chemical agents
- Exposition to high damp percentages
- They can be oiled more than once
- They can operate at maximum temperatures between -35 °C and 120 °C.

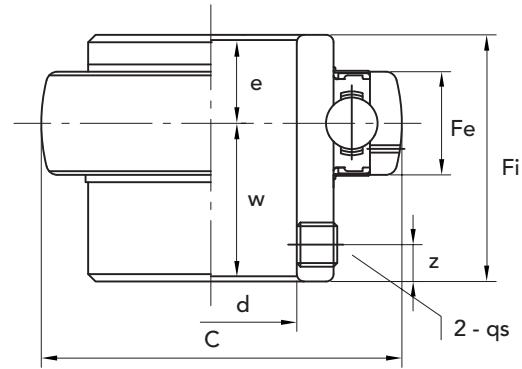
UC 200

UC	PART NUMBER	shaft hole Ø mm	DIMENSIONS mm							dynamic load N	static load N	weight kg
			C	Fi	Fe	e	w	z	qs			
201	93000201	12	47	31,0	17	12,7	18,3	4,8	M6x1,0	10000	6300	0,21
202	93000202	15	47	31,0	17	12,7	18,3	4,8	M6x1,0	10000	6300	0,19
203	93000203	17	47	31,0	17	12,7	18,3	4,8	M6x1,0	10000	6300	0,18
204	93000204	20	47	31,0	17	12,7	18,3	4,8	M6x1,0	10000	6300	0,16
205	93000205	25	52	34,0	17	14,3	19,7	5,5	M6x1,0	11000	7100	0,20
206	93000206	30	62	38,1	19	15,9	22,2	6,0	M6x1,0	15200	10200	0,32
207	93000207	35	72	42,9	20	17,5	25,4	6,5	M8x1,0	20100	13900	0,48
208	93000208	40	80	49,2	21	19,0	30,2	8,0	M8x1,0	25600	18100	0,64
209	93000209	45	85	49,2	22	19,0	30,2	8,0	M8x1,0	25600	18100	0,68
210	93000210	50	90	51,6	24	19,0	32,6	10	M10x1,0	27500	20200	0,82
211	93000211	55	100	55,6	25	22,2	33,4	10	M10x1,0	34000	25500	1,11
212	93000212	60	110	65,1	27	25,4	39,7	10	M10x1,0	41000	31500	1,54
213	93000213	65	120	65,1	28	25,4	39,7	10	M10x1,0	44800	34700	1,86
214	93000214	70	125	74,6	30	30,2	44,4	12	M12x1,5	48700	38100	2,06
215	93000215	75	130	77,8	30	33,3	44,5	12	M12x1,5	51900	41900	2,21
216	93000216	80	140	82,6	33	33,3	49,3	14	M12x1,5	57000	45500	2,79
217	93000217	85	150	85,7	35	34,1	51,6	14	M12x1,5	66000	53200	3,45
218	93000218	90	160	96,0	37	39,7	56,3	14	M12x1,5	75000	61700	4,35



CAD drawings available on our site
www.chiaravalli.com

Quantity, availability and prices
on B2B Chiaravalli



UK 200

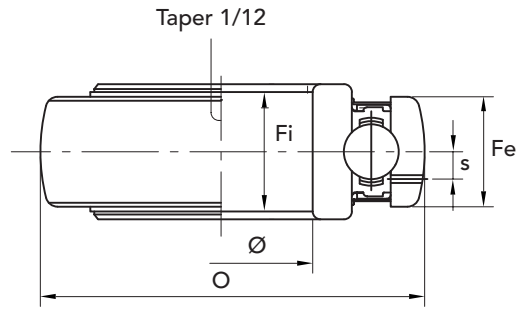

UK	PART NUMBER	shaft hole Ø mm	DIMENSIONS mm					dynamic load N	static load N	weight kg
			O	Fi	Fe	Fi (taper)	s			
207	93010207	30	72	28	20	30	5,9	20300	14000	0,37
208	93010208	35	80	29	21	34	6,2	23000	16000	0,47
209	93010209	40	85	31	22	36	6,6	25700	18100	0,52
210	93010210	45	90	31	24	36	6,5	27600	20100	0,59
211	93010211	50	100	34	25	40	7,0	34000	25500	0,80
212	93010212	55	110	36	27	47	7,6	41000	31500	1,02

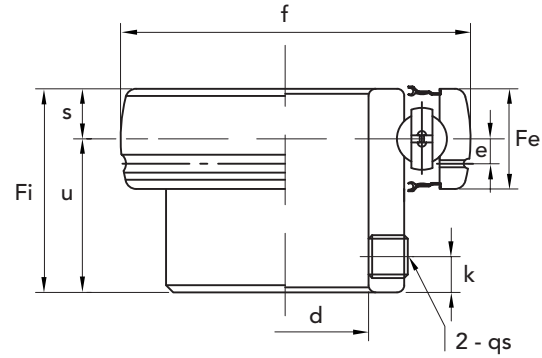

SB RE-LUBRICATING 200

SB	PART NUMBER	shaft hole Ø mm	DIMENSIONS mm									dynamic load N	static load N	weight kg
			Fe	f	F1	s	u	k	e	qs				
201	93020201	12	12	40	22	6,0	16,0	4,5	3,6	M5x0,8	7600	4500	0,10	
202	93020202	15	12	40	22	6,0	16,0	4,5	3,6	M5x0,8	7600	4500	0,10	
203	93020203	17	12	40	22	6,0	16,0	4,5	3,6	M5x0,8	7600	4500	0,10	
204	93020204	20	14	47	25	7,0	18,0	4,5	3,9	M6x1,0	10000	6300	0,15	
205	93020205	25	15	52	27	7,5	19,5	5,5	3,9	M6x1,0	11000	7100	0,18	
206	93020206	30	16	62	30	8,0	22,0	5,5	5,0	M6x1,0	15200	10200	0,27	
207	93020207	35	17	72	32	8,5	23,5	6,5	5,5	M8x1,0	20100	13900	0,42	
208	93020208	40	18	80	34	9,0	25,0	7,0	6,0	M8x1,0	25600	18100	0,60	
209	93020209	45	19	85	41,2	9,5	31,7	8,2	6,3	M8x1,0	32600	24500	0,80	
210	93020210	50	20	90	41,6	10,0	31,6	9,2	6,5	M8x1,0	35800	23000	0,83	

CAD drawings available on our site
www.chiaravalli.com

Quantity, availability and prices
on B2B Chiaravalli





SA RE-LUBRICATING 200

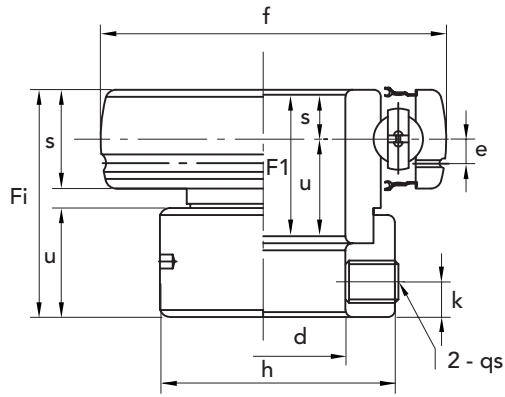

SA	PART NUMBER	shaft hole Ø mm	DIMENSIONS mm											dynamic load N	static load N	weight kg
			Fe	f	F1	s	u	Fi	h	o	k	e	qs			
201	93030201	12	12	40	19,1	6,0	13,1	28,6	28,6	13,5	5,0	3,6	M6x1,0	9600	4800	0,13
202	93030202	15	12	40	19,1	6,0	13,1	28,6	28,6	13,5	5,0	3,6	M6x1,0	9600	4800	0,13
203	93030203	17	12	40	19,1	6,0	13,1	28,6	28,6	13,5	5,0	3,6	M6x1,0	9600	4800	0,13
204	93030204	20	14	47	21,5	7,0	14,5	31,0	33,3	13,5	5,0	3,9	M6x1,0	10000	6300	0,15
205	93030205	25	15	52	21,5	7,5	14	31,0	38,1	13,5	5,0	3,9	M6x1,0	11000	7100	0,22
206	93030206	30	16	62	23,8	8,0	15,8	35,7	44,5	15,9	6,0	5	M8x1,0	15200	10200	0,30
207	93030207	35	17	72	25,4	8,5	16,9	38,9	55,6	17,5	6,5	5,5	M8x1,0	20100	13900	0,50
208	93030208	40	18	80	30,2	9,0	21,2	43,7	60,3	18,3	6,5	6,0	M8x1,0	25600	18100	0,67
209	93030209	45	19	85	30,2	9,5	20,7	43,7	63,5	18,3	6,5	6,3	M8x1,0	33000	21000	0,73
210	93030210	50	20	90	30,2	10,0	20,2	43,7	69,9	18,3	6,5	6,5	M8x1,0	35000	23000	0,83

BALL BEARINGS SERIES SA RE-LUBRICATING 200

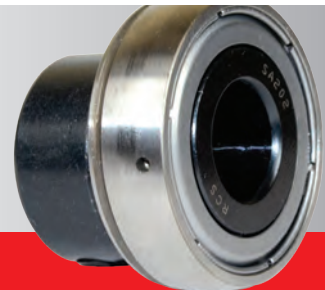



USING TEMPERATURES AND MATERIALS

Description	Materials
Frame	AISI 304
Grubscrew	AISI 304
Cage	AISI 321
Ring and frame	AISI 321
Internal and external ring	AISI 440C
Ball	AISI 404C
Nipple	AISI 302
Operating temperature	-20° +120°

Clamping torque

GRUBSCREW	Bearing n°	Clamping torque (N//m)
M6 X 1	SUC 204-206	3,9
M8 X 1	SUC 207-209	8,3
M10 X 1	SUC 210	16

TYPICAL APPLICATIONS

Machines for food, pharmaceutical, Chemical and agricultural Industry...

Where rustproofing and anticorrosion features are required.



SUC 200

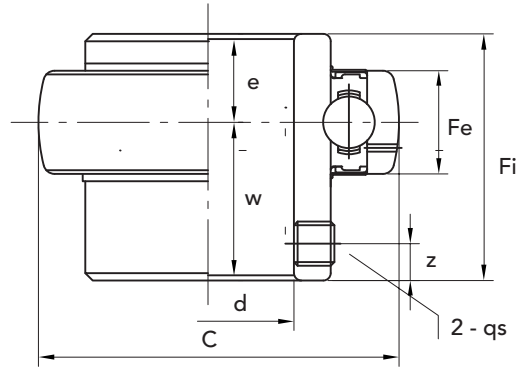

INOX BALL BEARINGS SERIES SUC 200

SUC	PART NUMBER	shaft hole Ø mm	DIMENSIONS mm							dynamic load N	static load N	weight kg
			C	Fi	Fe	e	w	z	qs			
203	93009203	17	47	31,0	17	12,7	18,3	4,8	M6x1,0	10000	6300	0,18
204	93009204	20	47	31,0	17	12,7	18,3	4,8	M6x1,0	10000	6300	0,16
205	93009205	25	52	34,0	17	14,3	19,7	5,5	M6x1,0	11000	7100	0,20
206	93009206	30	62	38,1	19	15,9	22,2	6,0	M6x1,0	15200	10200	0,32
207	93009207	35	72	42,9	20	17,5	25,4	6,5	M8x1,0	20100	13900	0,48
208	93009208	40	80	49,2	21	19,0	30,2	8,0	M8x1,0	25600	18100	0,64
209	93009209	45	85	49,2	22	19,0	30,2	8,0	M8x1,0	25600	18100	0,68
210	93009210	50	90	51,6	24	19,0	32,6	10	M10x1,0	27500	20200	0,82





BUSHES SERIES H23...

H	PART NUMBER	Shaft hole Ø mm
2307	93002307	30
2308	93002308	35
2309	93002309	40
2310	93002310	45
2311	93002311	50
2312	93002312	55



COVERS FOR CAST IRON PILLOW BLOCKS

CLOSED COVERS

OPEN COVERS WITH GASKET



for pillow block	PART NUMBER
202	93320202
203	93320203
204	93320204
205	93320205
206	93320206
207	93320207
208	93320208
209	93320209
210	93320210
211	93320211



for pillow block	PART NUMBER
202	93330202
203	93330203
204	93330204
205	93330205
206	93330206
207	93330207
208	93330208
209	93330209
210	93330210
211	93330211

COVERS FOR PRESSED STEEL HOUSING AND THERMOPLASTIC PILLOW BLOCKS

CLOSED COVERS

OPEN COVERS WITH GASKET



for pillow block	PART NUMBER
202	93329202
203	93329203
204	93329204
205	93329205
206	93329206
207	93329207
208	93329208
209	93329209
210	93329210
211	93329211



for pillow block	PART NUMBER
203	93339203
204	93339204
205	93339205
206	93339206
207	93339207
208	93339208
209	93339209
210	93339210

BUSHES SERIES H23... COVERS FOR PILLOW BLOCKS



SERIE F - FL - P

for pillow block	d	PART NUMBER
BS203	17	93349203
BS204	20	93349204
BS205	25	93349205
BS206	30	93349206
BS207	35	93349207
BS208	40	93349208
BS209	45	93349209
BS210	50	93349210



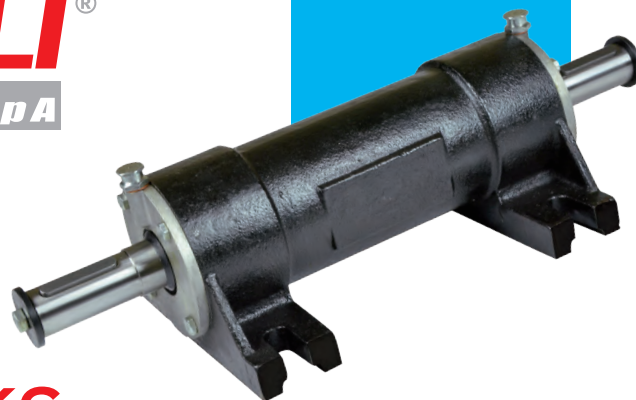

MONOBLOCK PILLOW BLOCKS RCM[®] BRAND

PILLOW BLOCKS

RCM SERIES	page 28
Nominal torque and power rating	31
Diagram for the choice of RCM pillow blocks	32
RCM SERIES AS standard shaft	34
RCM SERIES AL long shaft	36
RCM SERIES RCM-AL for cooling fan	38
NON-ROTATING GROUP	39



MONOBLOCK PILLOW BLOCKS BRAND RCM®

RCM - AS Standard shaft

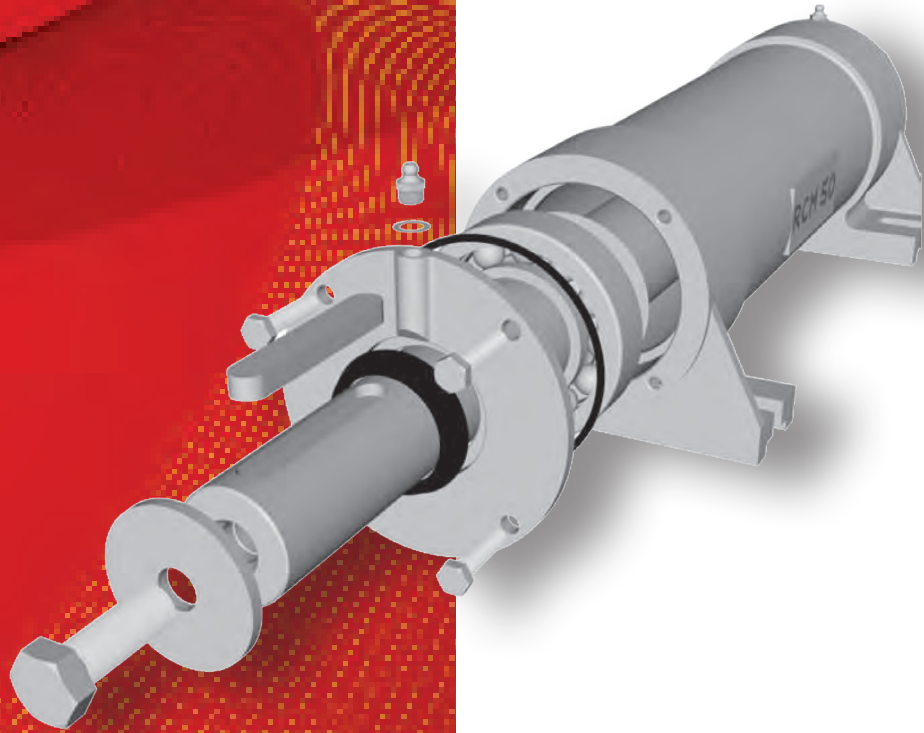
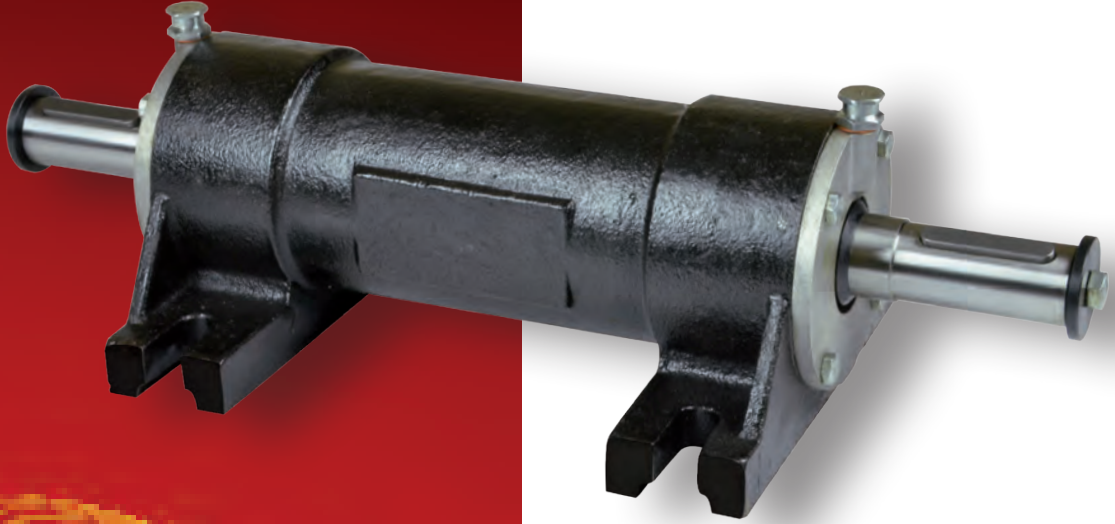



RCM - AL
Long shaft

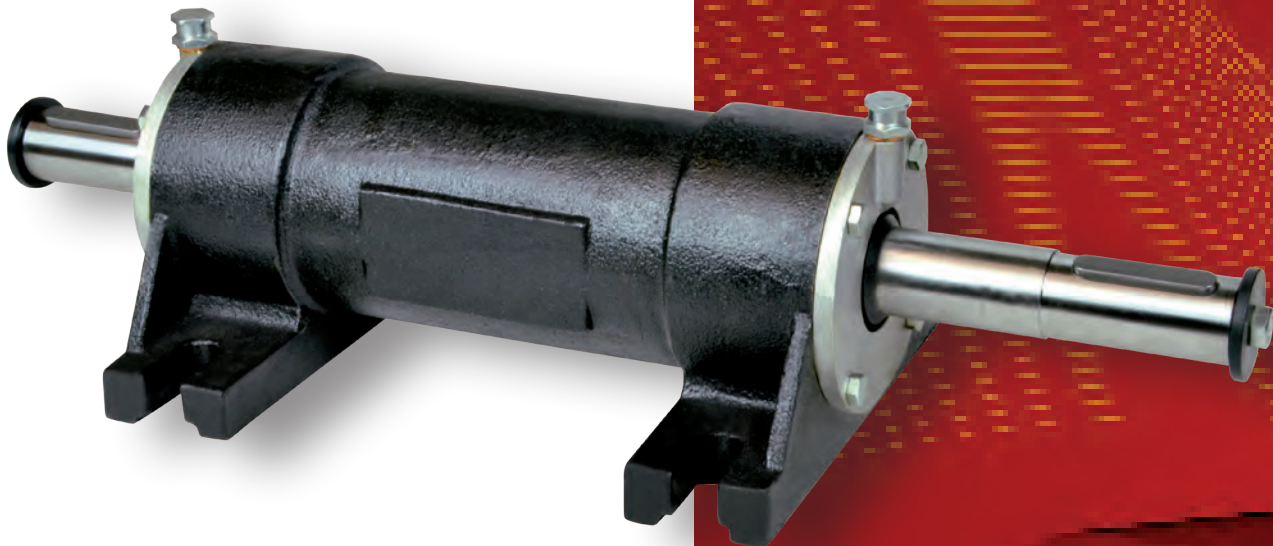

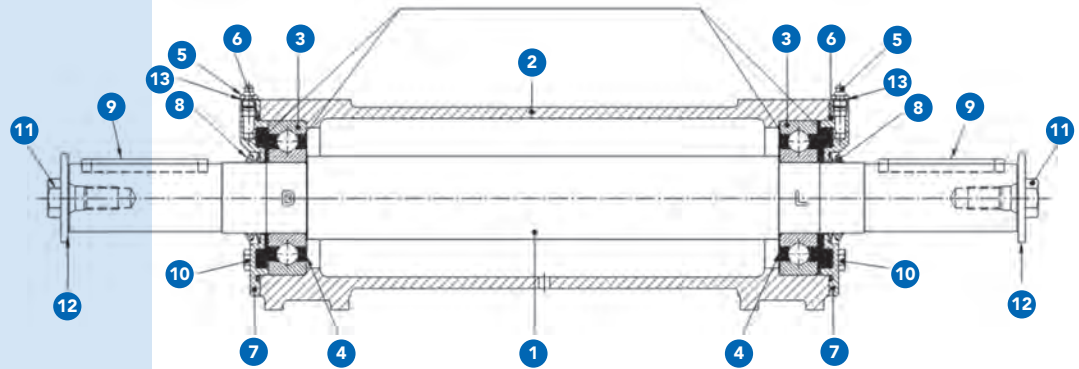

DESCRIPTION

- 1 Steel shaft
- 2 Casing cast iron
- 3 Bearing series 63XX
- 4 Disc retainer
- 5 Galvanized grease
- 6 Seal OR
- 7 Cover
- 8 Ring V-ring
- 9 Key
- 10 Cover zinc screw
- 11 Head zinc screw
- 12 Head washer
- 13 Copper washer

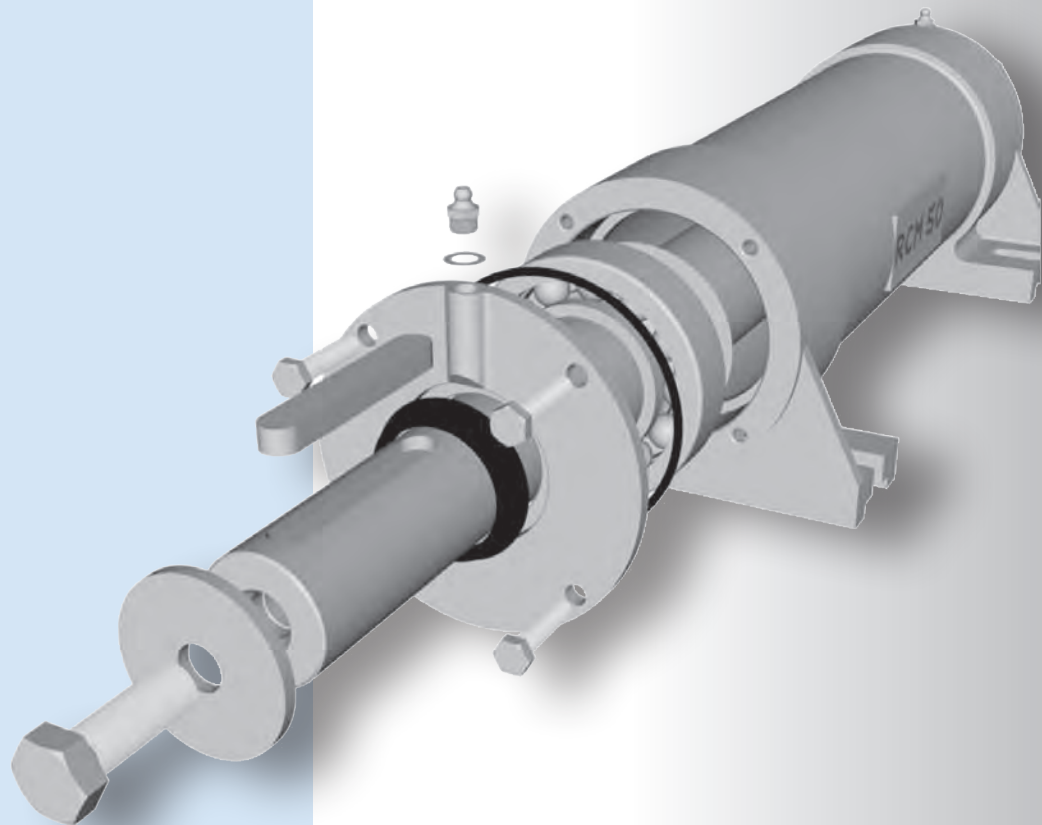

Fill with grease L G M T - 2 S K F





SELECTION CRITERIA OF PILLOWS BLOCKS

The choice of the pillow block is carried out by the curves of power if, the motor type is applied directly, or a gearbox equip the motor.

The maximum output values of the powers and torques are calculated with service factor $F_s=1$

These values must therefore be adapted to the needs and safety criteria of 'user.

THREE-PHASE ASYNCHRONOUS CAGE MOTOR - POWERS IN ACCORDANCE WITH REGULATIONS IEC-72

TYPE	Maximum torque (Nm)	Power with 8 motor poles turns/min. 750 (KW)	Power with 6 motor poles turns/min. 1000 (KW)	Power with 4 motor poles turns/min. 1500 (KW)	Power with 2 motor poles turns/min. 3000 (KW)
RCM 25	16	1,1	1,5	2,2	4,5
RCM 30	28	2,2	3	4,5	9
RCM 35	56	4	5,5	7,5	15
RCM 40	70	5,5	7,5	11	22
RCM 45	125	9,5	11	18,5	37
RCM 50	200	15	18,5	30	55
RCM 55	240	18,5	22	37	75
RCM 60	380	30	37	55	110
RCM 65	480	37	45	75	132
RCM 70	600	45	55	90	160
RCM 75	1000	75	90	132	250
RCM 80	1300	90	132	200	375

PILLOW BLOCKS BRAND RCM® NOMINAL TORQUE AND DRIVING POWER

PLEASE NOTE:

All data and performance are listed in the catalogue for safety factor $F_s=1$

CAD drawings available on our site
www.chiaravalli.com

Quantity, availability and prices
 on B2B Chiaravalli



DIAGRAM FOR THE CHOICE OF PILLOW BLOCKS RCM

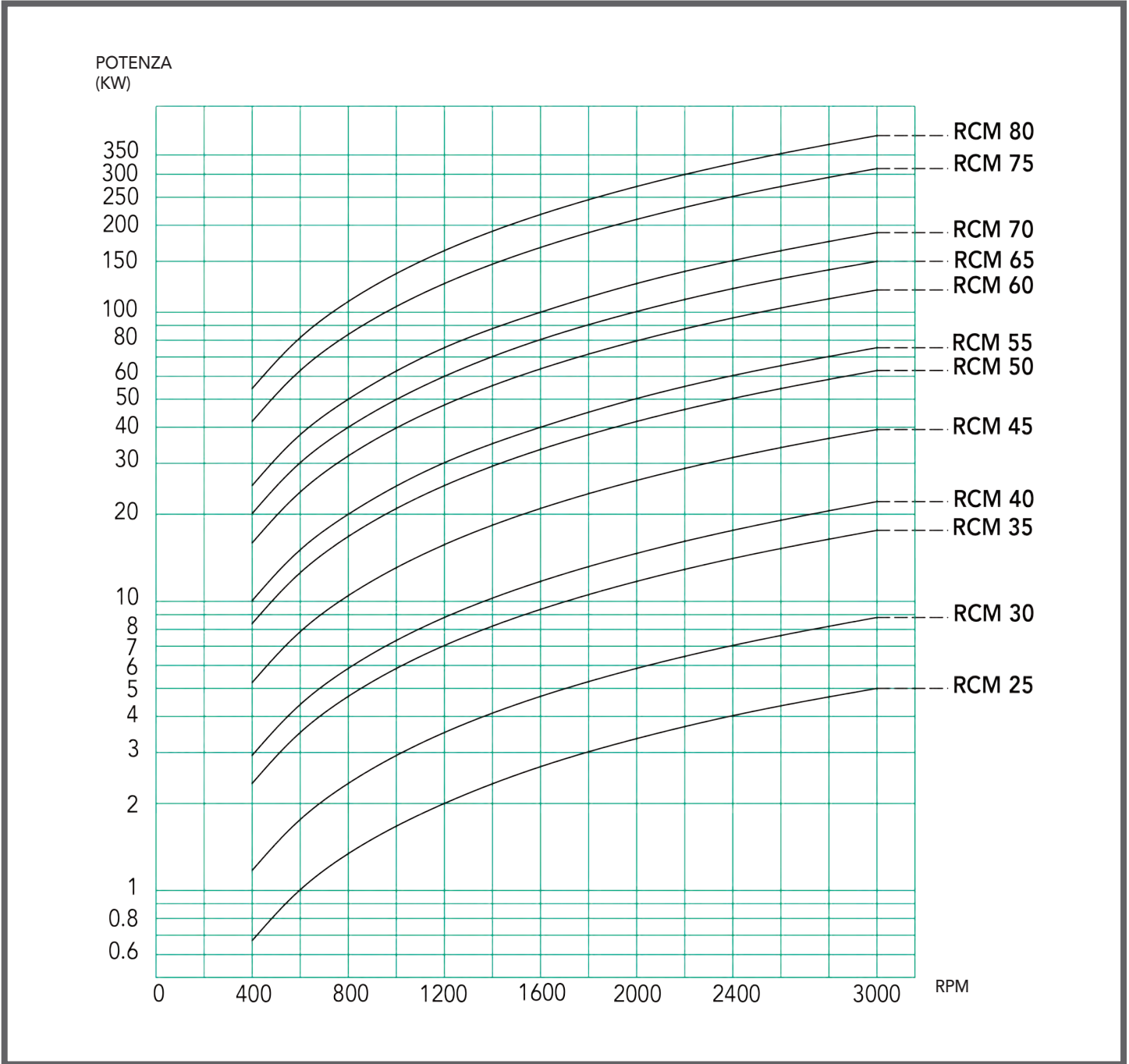

PLEASE NOTE:

All data and performance are listed in the catalogue for safety factor $F_s=1$

CAD drawings available on our site
www.chiaravalli.com

Quantity, availability and prices
 on B2B Chiaravalli



ALLOWABLE LOAD ON THE SHAFT "LOCKED" SIDE DEPENDING ON THE SHAFT OPERATION SPEED

If the connection between the drive motor and the support block, or between the support and the user is carried out by means which generate radial loads on the shaft end, you should verify that these loads are less than the allowable loads shown in the below graph. The maximum radial loads shown in the graphs are calculated with service factor $F_s=1$ and apply to an application point at "x" distance from the shaft.

For radial loads applied at a distance greater than and equal to $1.5x$, the value indicated by the graphs must be multiplied by an adjustment factor equal to 0.67

Even the radial loads must be adapted to the specific needs and safety criteria chosen by the user.

ALLOWABLE LOAD ON THE SHAFT "LOCKED" SIDE DEPENDING ON THE SHAFT OPERATION SPEED

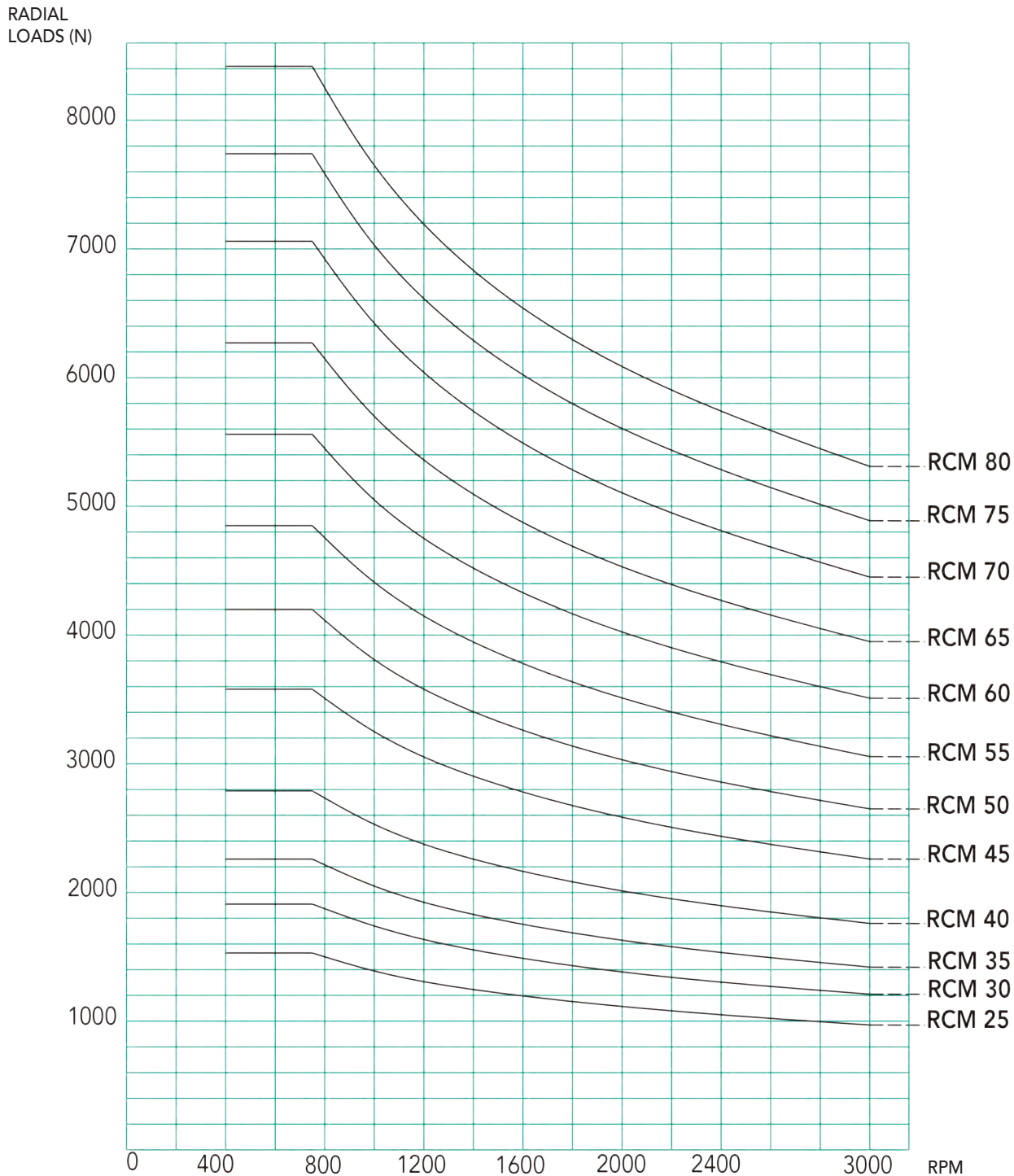

PLEASE NOTE:

All data and performance are listed in the catalogue for safety factor $F_s=1$

CAD drawings available on our site www.chiaravalli.com

Quantity, availability and prices on B2B Chiaravalli



For models
AS 45 - 50 - 55 - 60 - 70 - 75 - 80
can be supplied a non-rotating group
EUROPEAN PATENT N° 03425164.5
fitted in place of the side cover
locked bearing (b)

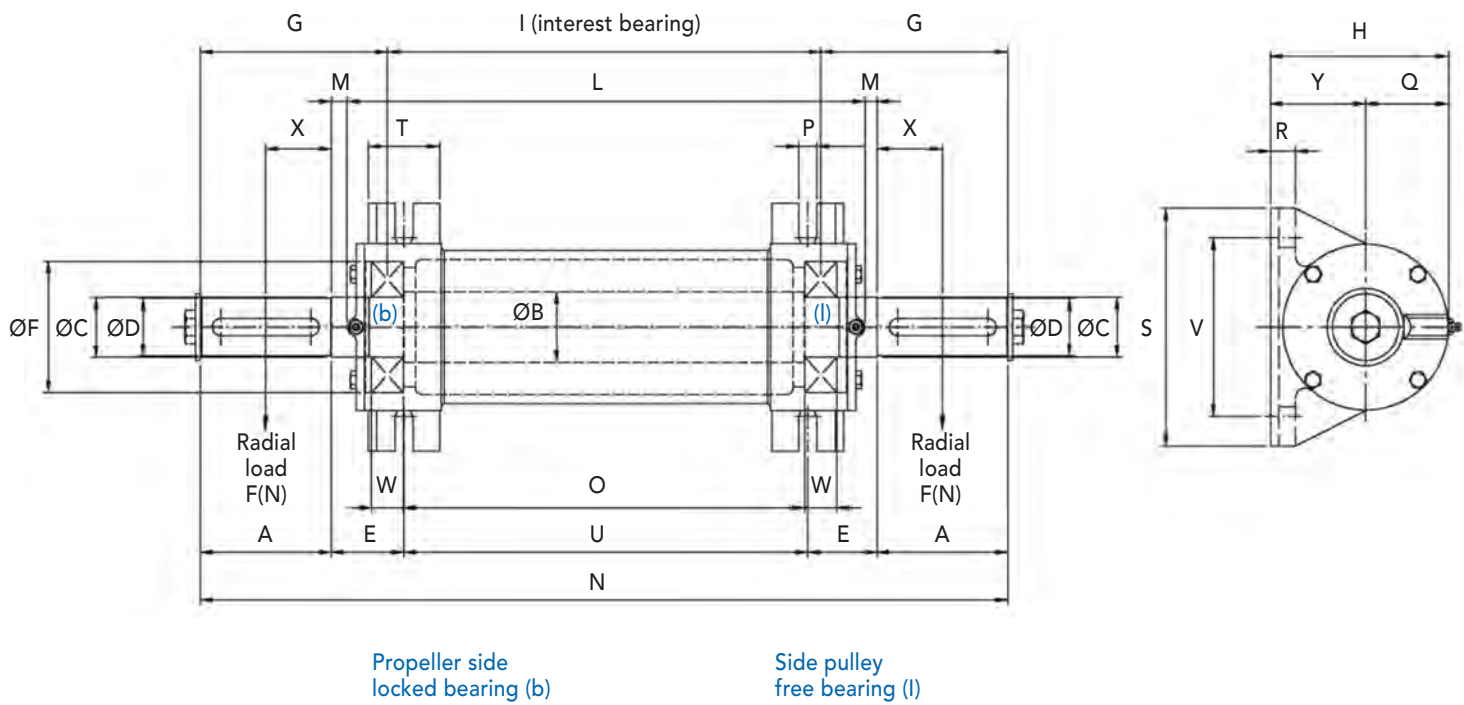



For models
AS 45 - 50 - 55 - 60 - 70 - 75 - 80
can be supplied a non-rotating group
EUROPEAN PATENT N° 03425164.5
fitted in place of the side cover
locked bearing (b)

TYPE	P. NUMBER	ØD	A	E	L	U	ØF	P	T	ØB	N	G	I	O	ØC	Q	H	R	V	S	Y	W	M	X
25	95000251	24j6	50	50	281	200	62	15	50	34	400	88,5	222	205	25	45	105	20	135	180	60	17	9,5	25
30	95000301	28j6	60	50	281	200	72	15	50	39	420	99,5	220	201	30	50	110	20	135	180	60	19	9,5	30
35	95000351	32k6	60	56	352	265	80	15	50	43	497	103,5	288	267	35	54	124	20	145	195	70	21	12,5	30
40	95000401	38k6	80	56	351	265	90	15	50	48	537	125	286	263	40	58	128	20	145	195	70	23	13	40
45	95000451	42k6	110	60	434	340	100	15	60	53	680	156	367	342	45	70	150	20	150	200	80	25	13	55
50	95000501	48k6	110	60	435	340	110	15	60	59	680	156,5	366	339	50	70	150	20	150	200	80	27	12,5	55
55	95000551	48k6	110	86	571	448	120	18	80	64	840	169,5	500	471	55	75	165	24	180	230	90	29	24,5	55
60	95000601	55m6	110	86	570	448	130	18	80	71	840	171	497	466	60	85	175	24	180	230	90	31	25	55
65	95000651	60m6	140	75	574	448	140	20	90	76	878	191	495	462	65	84	184	24	190	250	100	33	12	70
70	95000701	65m6	140	75	574	448	150	20	90	81	878	192	492	457	70	90	190	24	190	250	100	35	12	70
75	95000751	70m6	150	80	594	460	160	22	100	86	930	209	511	474	75	102	202	28	280	355	100	37	18	75
80	95000801	75m6	150	85	598	460	170	22	100	91	930	210	509	470	80	102	202	28	280	355	100	39	16	75

TYPE	P. NUMBER	Bearing	Head screw	Head washer	Key	Weight kg.
25	95000251	6305	M8	8,5 x 36 x 4	8 x 7 x 35	8
30	95000301	6306	M8	8,5 x 36 x 4	8 x 7 x 45	10
35	95000351	6307	M12	12,5 x 48 x 4	10 x 8 x 45	14
40	95000401	6308	M12	12,5 x 48 x 4	10 x 8 x 60	17
45	95000451	6309	M16	16,5 x 63 x 5	12 x 8 x 90	24
50	95000501	6310	M16	16,5 x 63 x 5	14 x 9 x 90	28
55	95000551	6311	M16	16,5 x 85 x 6	14 x 9 x 90	43
60	95000601	6312	M16	16,5 x 85 x 6	16 x 10 x 90	49
65	95000651	6313	M16	16,5 x 85 x 6	18 x 11 x 120	56
70	95000701	6314	M16	16,5 x 85 x 6	18 x 11 x 120	61
75	95000751	6315	M20	20,5 x 100 x 8	20 x 12 x 130	89
80	95000801	6316	M20	20,5 x 100 x 8	20 x 12 x 130	90



For models
 AS 45 - 50 - 55 - 60
 can be supplied a non-rotating group
 EUROPEAN PATENT N° 03425164.5
 fitted in place of the side cover
 locked bearing (b)

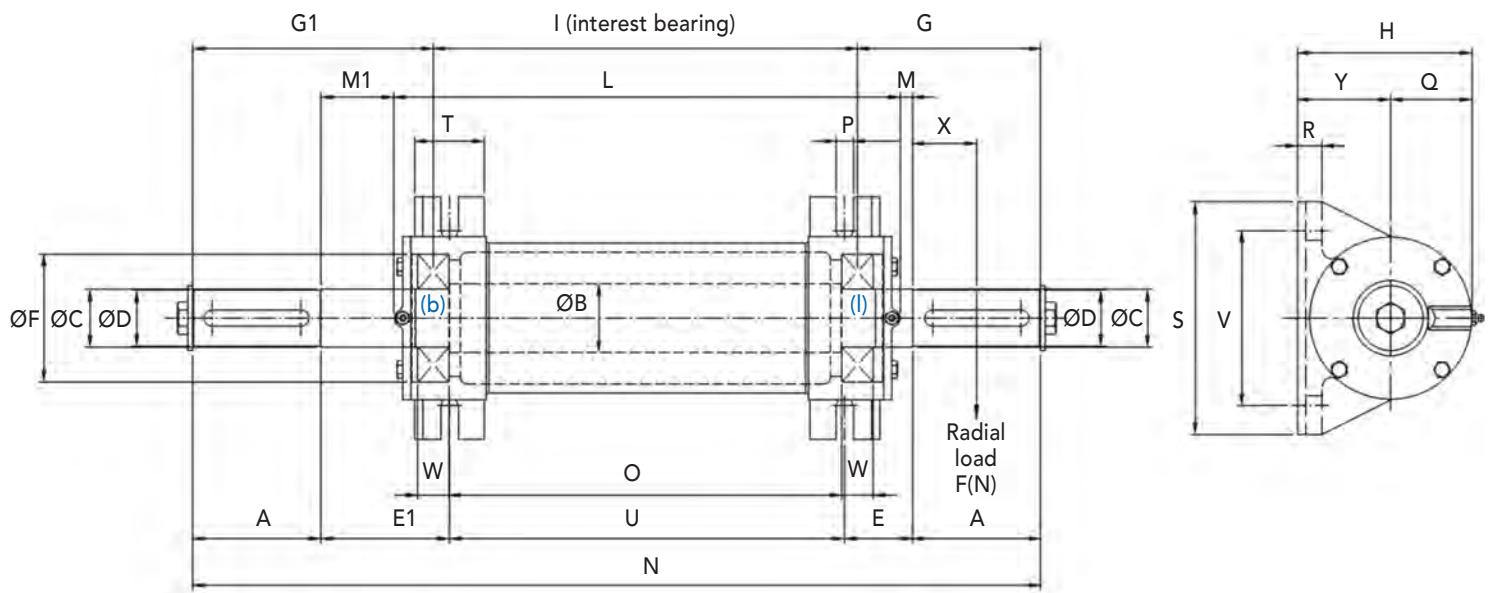

Propeller side
 locked bearing (b)

Side pulley
 free bearing (l)



For models
AS 45 - 50 - 55 - 60
can be supplied a non-rotating group
EUROPEAN PATENT N° 03425164.5
fitted in place of the side cover
locked bearing (b)

TYPE	P. NUMBER	ØD	A	E	E1	L	U	ØF	P	T	ØB	N	G	G1	I	O	ØC	Q	H	R	V	S	Y	W	M	X	G1
30	95000302	28j6	60	50	90	281	200	72	15	50	39	460	99,5	139,5	220	201	30	50	110	20	135	180	60	19	9,5	30	49,5
35	95000352	32k6	60	56	100	352	265	80	15	50	43	541	103,5	147,5	288	267	35	54	124	20	145	195	70	21	12,5	30	56,5
40	95000402	38k6	80	56	110	351	265	90	15	50	48	591	125	179	286	263	40	58	128	20	145	195	70	23	13	40	67
45	95000452	42k6	110	60	110	434	340	100	15	60	53	730	156	206	367	342	45	70	150	20	150	200	80	25	13	55	63
50	95000502	48k6	110	60	110	435	340	110	15	60	59	730	156,5	206,5	366	339	50	70	150	20	150	200	80	27	12,5	55	62,5
55	95000552	48k6	110	86	140	571	448	120	18	80	64	894	169,5	223,5	500	471	55	75	165	24	180	230	90	29	24,5	55	78,5
60	95000602	55m6	110	86	140	570	448	130	18	80	71	894	171	225	497	466	60	85	175	24	180	230	90	31	25	55	79
65	95000652	60m6	140	86	140	574	443	140	20	90	76	955	203	257	495	462	65	84	184	24	190	250	100	33	23,5	70	77,5

TYPE	P. NUMBER	Bearing	Head screw	Head washer	Keyway	Weight kg.
30	95000302	6306	M8	8,5 x 36 x 4	8 x 7 x 45	10
35	95000352	6307	M12	12,5 x 48 x 4	10 x 8 x 45	14
40	95000402	6308	M12	12,5 x 48 x 4	10 x 8 x 60	17
45	95000452	6309	M16	16,5 x 63 x 5	12 x 8 x 90	24
50	95000502	6310	M16	16,5 x 63 x 5	14 x 9 x 90	28
55	95000552	6311	M16	16,5 x 85 x 6	14 x 9 x 90	43
60	95000602	6312	M16	16,5 x 85 x 6	16 x 10 x 90	49
65	95000652	6313	M16	16,5 x 85 x 6	18 x 11 x 120	58



RCM-AL FOR COOLING FAN

TYPE	PART NUMBER	A	B	C
30	95000303	115	28	29,8
35	95000353	135	30	34,8
40	95000403	135	30	39,8
45	95000453	155	32	44,8
50	95000503	155	32	49,8
55	95000553	170	32	54,8
60	95000603	170	32	59,8
65	95000653	188	30	64,8

TYPE	PART NUMBER
30	95000001
35-40	95000002
45-50	95000003
55-60	95000004

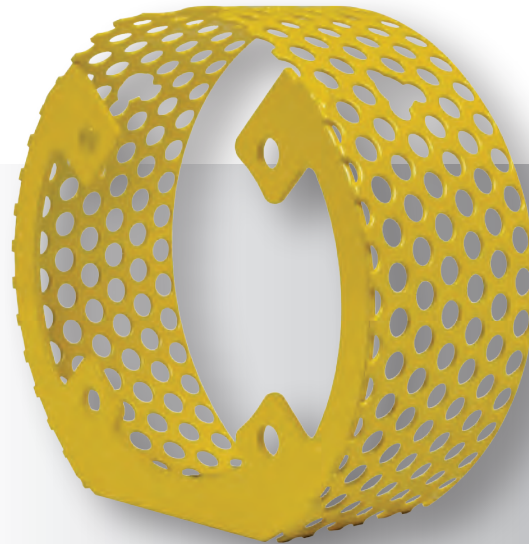
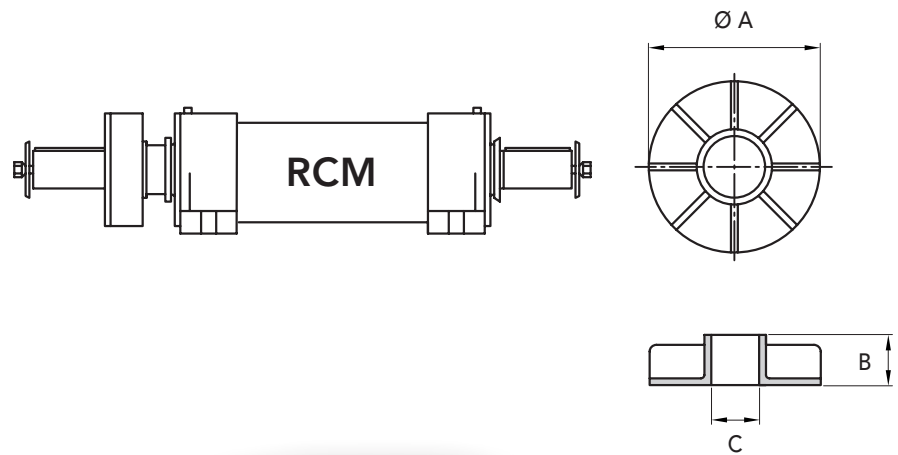

FAN PROTECTION



FAN



RCM-AS Models with non-rotating group

Type	PART NUMBER	max RPM without load n°/1'
45	95000045	500
50	95000050	475
55	95000055	400
60	95000060	350
65	95000065	350
70	95000070	330
75	95000075	325
80	95000080	300

RCM-AL Models with non-rotating group

Type	PART NUMBER	max RPM without load n°/1'
45	95000045	500
50	95000050	475
55	95000055	400
60	95000060	350
65	95000065	350

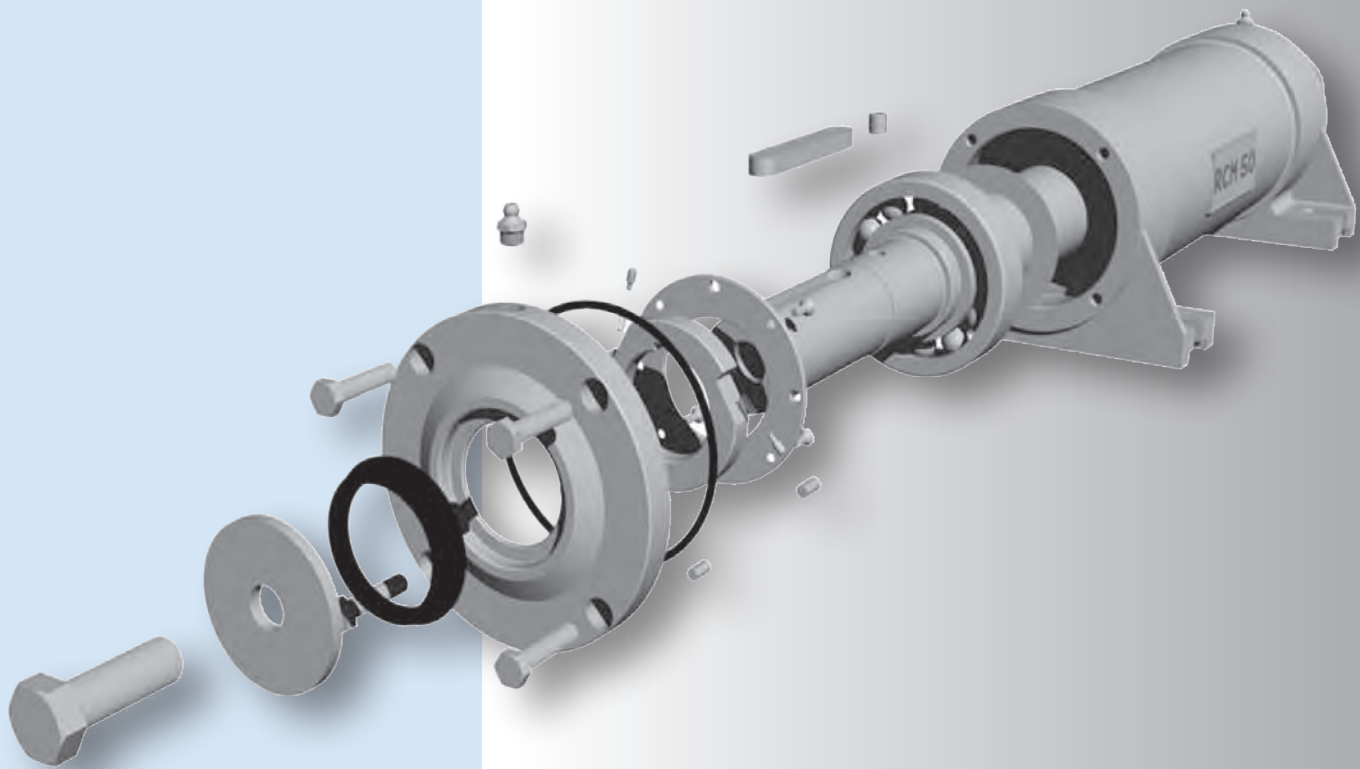

EUROPEAN PATENT N° 03425164.5

PILLOW BLOCKS BRAND RCM® NON-ROTATING GROUP



ADJUSTABLE MOTOR MOUNTING

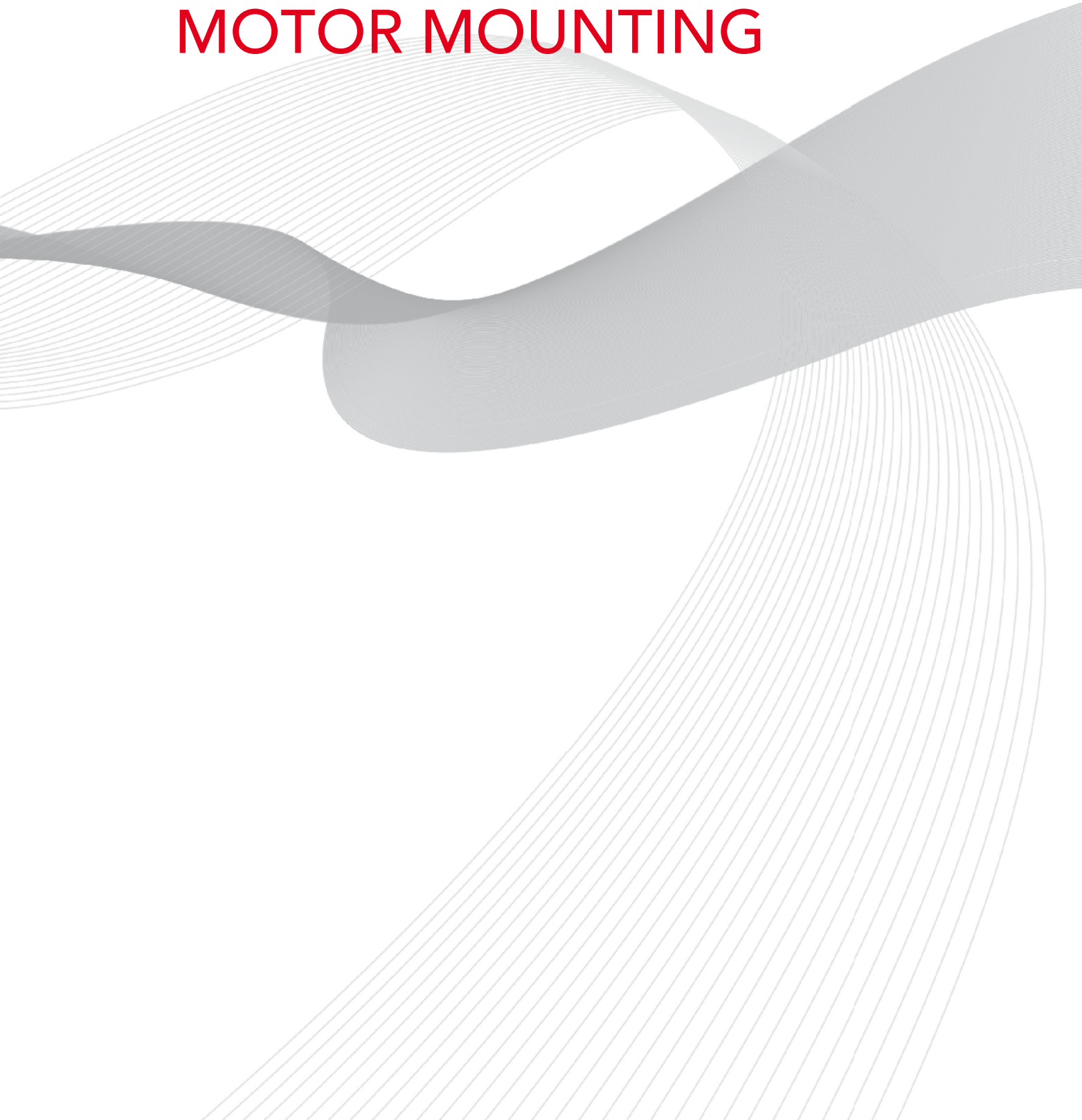

ADJUSTABLE MOTOR MOUNTING FOR ELECTRICAL MOTOR



ADJUSTABLE MOTOR MOUNTING FOR ELECTRICAL MOTOR

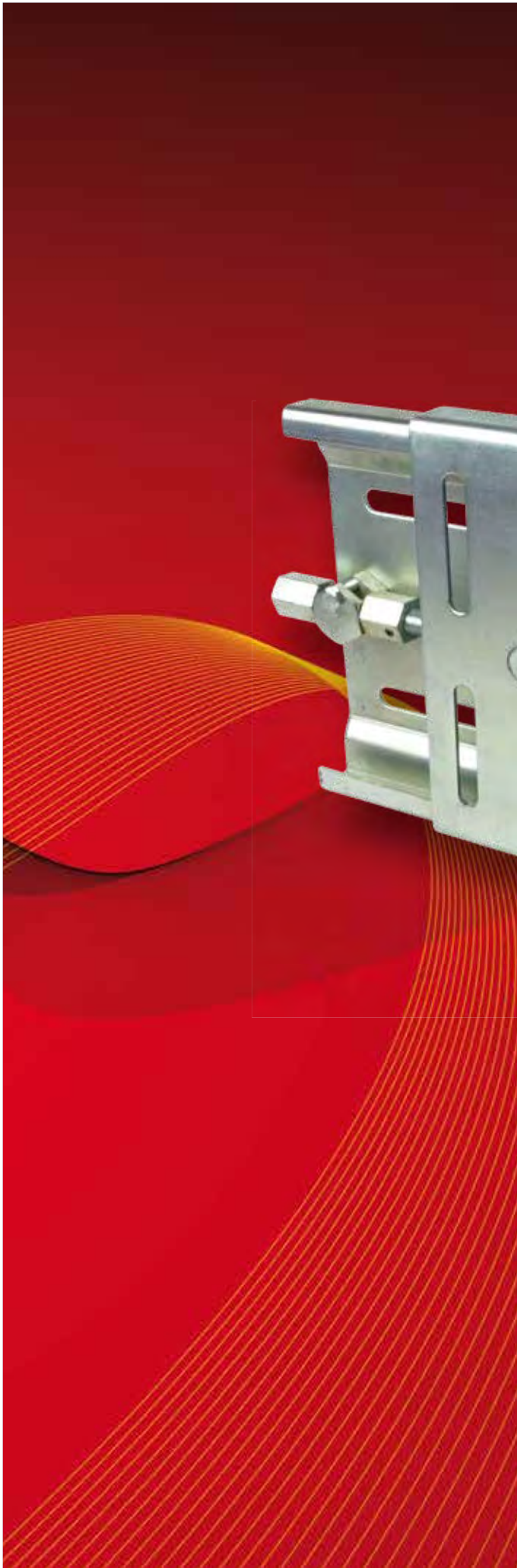



ADJUSTABLE MOTOR MOUNTING FOR ELECTRICAL MOTOR

3

MATERIAL

Zinc-coated sheet FE 430

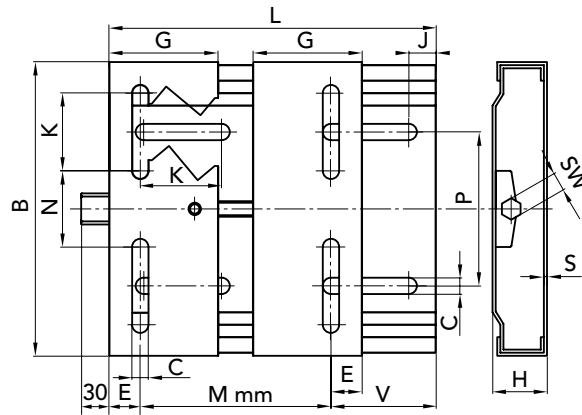

DIMENSIONS

MOTOR SIZE	TYPE	PART NUMBER	L	B	H	Mmin	G	E	J	K	C	N	P	SW	S
63/80	210	90100210	210	195	33	100	70	20	25	50	10,5	43	98	19	3
63/112	270	90100270	270	195	33	100	70	20	25	50	10,5	43	98	19	3
90/132	340	90100340	340	290	40	135	95	27	29	62,5	12,5	90	165	22	4
100/160	430	90100430	430	290	40	140	95	27	29	62,5	12,5	90	165	22	4
160/180	490	90100490	490	410	40	254	95	40	30	60	15	193	284	22	4

WIDTH REGULATION

TYPE	63	71	80	90	100	112	132	160	180	WEIGHT kg
210	70	58	45							2,2
270	130	118	105	90	70	40				2,8
340				140	130	100	75			6,7
430					216	186	160	122		7,5
490								156	131	10,8



Quantity, availability and prices
on B2B Chiaravalli

ADJUSTABLE MOTOR MOUNTING FOR ELECTRICAL MOTOR



IE 1

TYPE	POLES	POWER Kw	VOLTAGE V	CURRENT 400 V	TORQUE N/m	EFFICIENCY %	FACTOR COS. Ø	WEIGHT Kg.
CHT 56	B2	2	230/400	0.40	0.42	62.00	0.69	3.20
CHT56	B4	4	230/400	0.43	0.64	50.00	0.61	3.20
CHT63	A2	2	230/400	0.55	0.63	63.00	0.75	4.00
CHT63	B2	2	230/400	0.71	0.88	65.00	0.78	4.40
CHT63	C2	2	230/400	1.05	1.30	65.00	0.78	4.90
CHT63	A4	4	230/400	0.47	0.85	57.00	0.64	3.90
CHT63	B4	4	230/400	0.70	1.27	57.00	0.65	4.50
CHT63	C4	4	230/400	0.92	1.77	59.00	0.67	4.80
CHT63	B6	6	230/400	0.62	1.27	45.00	0.62	4.80
CHT71	A2	2	230/400	0.97	1.29	70.00	0.79	5.60
CHT71	B2	2	230/400	1.42	1.90	71.00	0.79	6.10
CHT71	A4	4	230/400	0.84	1.77	60.00	0.62	5.60
CHT71	B4	4	230/400	1.12	2.58	65.00	0.74	6.20
CHT71	C4	4	230/400	1.61	3.81	66.00	0.75	7.00
CHT71	A6	6	230/400	0.70	1.95	56.00	0.66	6.00
CHT71	B6	6	230/400	0.87	2.65	59.00	0.70	6.50
CHT71	C6	6	230/400	1.27	3.97	61.00	0.69	7.20
CHT80	A4	4	230/400	1.59	3.81	67.00	0.75	8.90
CHT80	A6	6	230/400	1.23	3.93	62.00	0.70	8.20
CHT80	B6	6	230/400	1.65	5.80	67.00	0.72	9.90

IE 2

IE 2 EFFICIENT MOTORS

From June 2011, motors with 2-4-6 poles with powers between 0,75 Kw and 375 Kw, commercialised in the European Union, will have to conform to the new EU MEPS (European Union Minimum Energy Performances Standard) regulation concerning the efficiency level in order to reduce consumes and CO2 emissions.

IE2 acronym on motor plates will show the belonging to this category.

TYPE	POLES	POWER Kw	VOLTAGE V	CURRENT 400 V	TORQUE N/m	EFFICIENCY %	FACTOR COS. Ø	WEIGHT Kg.
CHT80	A2	2	230/400	1.75	2.51	77.40	0.80	9.10
CHT80	B2	2	230/400	2.45	3.69	80.00	0.82	10.70
CHT80	C2	2	230/400	3.12	4.97	82.70	0.83	13.00
CHT80	B4	4	230/400	1.79	5.04	79.60	0.76	11.20
CHT80	C4	4	230/400	2.72	7.39	81.40	0.71	13.50
CHT90	S2	2	230/400	3.20	4.95	81.40	0.83	13.30
CHT90	L2	2	230/400	4.54	7.38	83.20	0.84	16.00
CHT90	S4	4	230/400	2.50	7.37	81.40	0.78	13.90
CHT90	L4	4	230/400	3.31	10.09	82.80	0.79	16.20
CHT90	M4	4	230/400	5.09	14.71	84.30	0.74	20.50
CHT90	S6	6	230/400	2.01	7.66	76.00	0.71	13.0
CHT90	L6	6	230/400	2.82	11.23	78.10	0.72	16.30
CHT100	LA2	2	230/400	5.88	10.05	84.60	0.87	23.00
CHT100	LA4	4	230/400	4.83	14.70	84.30	0.78	22.70
CHT100	LB4	4	230/400	6.33	20.00	85.50	0.80	26.50
CHT100	LA6	6	230/400	3.71	15.20	80.00	0.73	22.00
CHT 112	M2	2	230/400	7.56	13.13	86.00	0.89	27.00
CHT112	M4	4	230/400	8.23	26.60	86.60	0.81	32.50
CHT112	L4	4	230/400	11.25	36.57	87.90	0.80	39.00
CHT112	M6	6	230/400	5.17	22.30	81.80	0.75	29.50
CHT132	SA2	2	230/400	10.25	18.00	87.20	0.89	40.20
CHT132	SB2	2	230/400	13.80	24.47	88.10	0.89	45.00
CHT132	S4	4	230/400	11.00	36.22	87.90	0.83	44.00
CHT132	M4	4	230/400	14.50	50.00	88.70	0.84	53.50
CHT132	M6	6	230/400	8.86	40.42	84.60	0.77	45.00
CHT132	S6	6	230/400	6.84	30.48	83.30	0.76	36.10

* On request motors from 160 to 355 Kw

* Standard Volts 400/690

* ABB motors On request

* MGM brake motors On request

CAD drawings available on our site
www.chiaravalli.com

Quantity, availability and prices
 on B2B Chiaravalli



B5

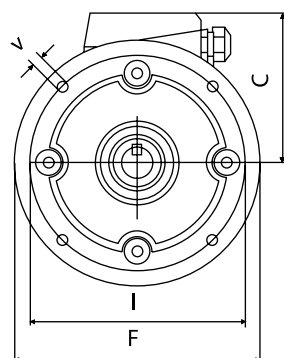
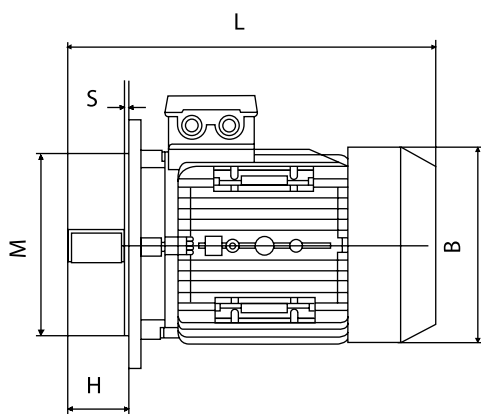
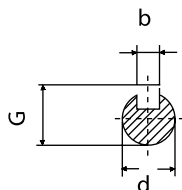

B14

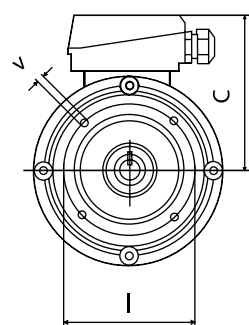
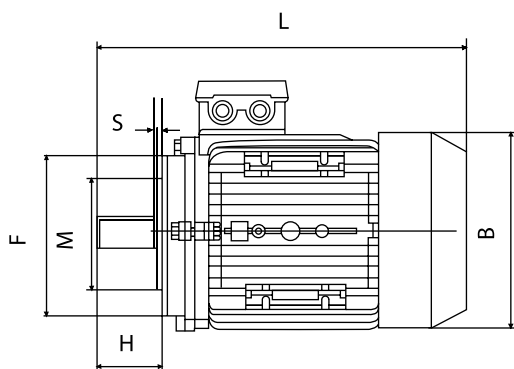
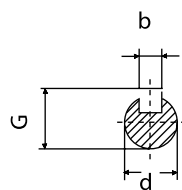

B3

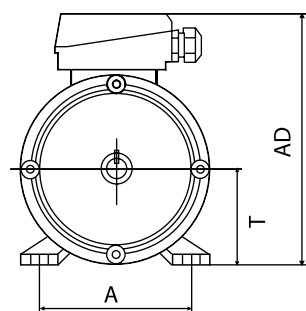
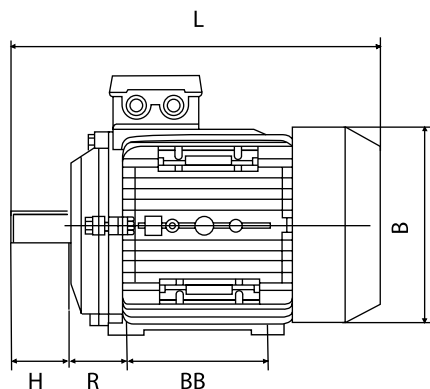
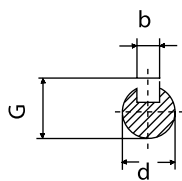

MOUNTING DIMENSIONS (mm)

TYPE	MOUNTING DIMENSIONS (mm)															DIMENSIONS						
	d	H	b	G	B5					B14					B3					B	C	L
					I	M	F	V	S	I	M	F	V	S	R	BB	A	T	AD			
56	9	20	3	10.2	98	80	120	7	3.0	65	50	80	M5	2.5	36	71	90	56	156	110	100	195
63	11	23	4	12.5	115	95	140	10	3.0	75	60	90	M5	2.5	40	80	100	63	173	123	110	215
71	14	30	5	16	130	110	160	10	3.5	85	70	105	M6	2.5	45	90	112	71	188	138	117	255
80	19	40	6	21.5	165	130	200	12	3.5	100	80	120	M6	3.0	50	100	125	80	217	155	137	290
90S	24	50	8	27	165	130	200	12	3.5	115	95	140	M8	3.0	56	100	140	90	235	176	145	310
90L/90LL	24	50	8	27	165	130	200	12	3.5	115	95	140	M8	3.0	56	125	140	90	235	176	145	335
100L	28	60	8	31	215	180	250	15	4.0	130	110	160	M8	3.5	63	140	160	100	252	197	152	386
112M	28	60	8	31	215	180	250	15	4.0	130	110	160	M8	3.5	70	140	190	112	292	220	180	395
132S	38	80	10	41	265	230	300	15	4.0	165	130	200	M10	4.0	89	140	216	132	325	257	195	436



1) ORDERS - Orders for special and standard material must always refer to offers made by CHIARAVALLI GROUP SpA.
The orders are binding for the client. Once work has commenced no cancellations or order reductions will be accepted unless the client reimburses the costs of the material and the work carried out up to the moment in which the order was suspended. The quantity despatched can vary by $\pm 5\%$ compared to the quantity ordered.

2) PRICES - The prices are those in force at the date of order. All prices are for goods delivered ex-works Premezzo, packing excluded. If there should be any increase in production and material costs over the duration of the supply, CHIARAVALLI GROUP SpA reserves the right to adapt the prices accordingly, even for orders in course.

3) TERMS OF DELIVERY - Only the terms of delivery indicated by CHIARAVALLI GROUP SpA are to be considered valid. However, they must only be considered as indicative. In the event of difficulty in the procurement of materials, strikes or in any event in all cases of force majeure, the terms of delivery will be automatically extended without CHIARAVALLI GROUP SpA having to pay any reimbursement for damages. The client is obligated to collect special material ordered when ready.

4) DELIVERIES - Deliveries are the responsibility of the purchaser and are carried out at his own risk and peril. Any claims for shortages must be presented within 8 days of receipt of the goods. If it is agreed that the cost of transport is to be paid, even if only in part, by CHIARAVALLI GROUP SpA, the latter reserves the right to choose the most economical means of transport.

5) PACKING - Packing will be invoiced at cost.

6) RETURNS - No returns for any reason will be accepted unless previously authorised and with packing, any customs clearance and the return paid for by the purchaser. To cover warehouse and administrative expenses a debit note will be issued for approx. 15% of the value of the goods returned.

7) WARRANTY - CHIARAVALLI GROUP SpA promises to repair or substitute free of charge any parts that they recognise as being defective. The questioned goods must be returned to the factory of CHIARAVALLI GROUP SpA, free of all expenses. The warranty will be considered cancelled in the event that the parts returned as defective have been repaired or tampered with. The repair of defective parts carried out by the purchaser will only be accepted after authorisation from CHIARAVALLI GROUP SpA and after their approval of the cost estimate. CHIARAVALLI GROUP SpA does not accept responsibility or pay any reimbursement for damages that occur during the use of their products, even if defective. Warranty is excluded for leakage of lubricant caused by wear of the oil seals.

8) RESPONSIBILITY - CHIARAVALLI GROUP SpA does not accept responsibility or pay any reimbursement for damages that occur during the use of their products, even if defective. CHIARAVALLI GROUP SpA declines all responsibility in the execution of parts to a client's design under any patents.

9) PAYMENTS - Only payments carried out in the manner and terms agreed will be considered valid. Once the due date of payment has passed, CHIARAVALLI GROUP SpA will calculate the interest on delayed payment at a rate that is 3% higher than the legal one, retaining the right to demand payment. In the event of delayed or missing payment by the purchaser, the company CHIARAVALLI GROUP SpA reserves the right to suspend deliveries of the orders in course or to demand advance payment without having to pay any reimbursement or compensation to the purchaser. Any dispute regarding materials in manufacture or already possessed by the purchaser does not free the latter from the commitment of making the payment by the agreed date and for the whole amount of the invoice without making any deductions.

10) OWNERSHIP - All of the goods despatched remain the property of CHIARAVALLI GROUP SpA until the invoice is fully paid.

11) COMPETENT COURT - Any controversy concerning business relations with CHIARAVALLI GROUP SpA will be dealt with under the jurisdiction of the Court of Busto Arsizio. Chiaravalli Group SpA accepts no responsibility for any errors in the production of this catalogue and reserves the right to add to the designs or dimensions of the listed products any modification called for by manufacturing requirements or due to evolution of the product.

The partial or total reproduction of the present catalogue is subject to written authorization of Company Chiaravalli Group S.p.A.



CHIARAVALLI Cz a.s.
Průmyslová 2083
59401 Velké Meziříčí
Česká republika
Tel. +420 566 502 030
www.chiaravalli.cz



CHIARAVALLI POLSKA Sp. z o.o.
ul. Polna 133
87 - 100 Toruń
Polska
Tel. + 48 56 623 30 00
www.chiaravalli.pl



Via per Cedrate, 476
21044 Cavaria con Premezzo (VA) · Italy
Tel. +39 0331 214 511
Fax +39 0331 218 175

www.chiaravalli.com
chiaravalli@chiaravalli.com

