

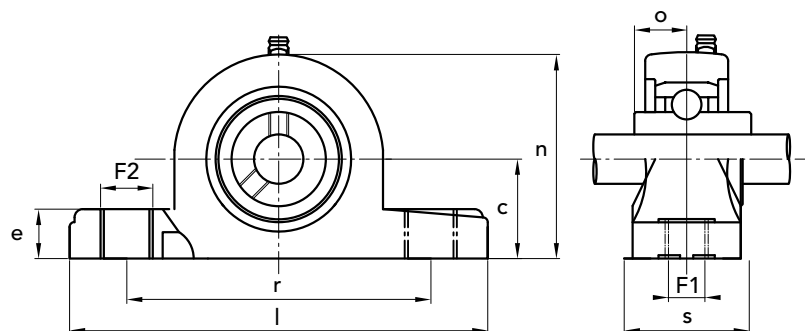

P 200

P	PART NUMBER	shaft hole Ø mm	DIMENSIONS mm									bearing mm	housing No.	weight kg
			c	l	r	s	F1	F2	e	n	o			
203	93191203	17	33,3	127	95	38	11	14	14,2	65,5	12,7	M10	P203	0,13
204	93191204	20	33,3	127	95	38	11	14	14,2	65,5	12,7	M10	P204	0,13
205	93191205	25	36,5	140,5	105	38	11	14	14,5	71	14,3	M10	P205	0,14
206	93191206	30	42,9	163	119	46	14	18	17,8	84	15,9	M12	P206	0,25
207	93191207	35	47,6	168	127	48	14	18	18	94,5	17,5	M12	P207	0,27
208	93191208	40	49,2	184	137	54	14	18	19,5	99	19	M12	P208	0,32
209	93191209	45	54	192	146	54	17	20	23	1,6	19	M16	P209	0,37
210	93191210	50	57,2	206	159	60	17	20	23	114	19	M16	P210	0,44

SUCP	PART NUMBER	shaft hole Ø mm	DIMENSIONS mm									bearing	housing No.	weight kg
			c	l	r	s	F1	F2	e	n	o			
205	93192205	25	36,5	140,5	105	38	11	14	14,5	71	14,3	SUC 205	P205	0,33
206	93192206	30	42,9	163	119	46	14	18	17,8	84	15,9	SUC 206	P206	0,56
207	93192207	35	47,6	168	127	48	14	18	18	94,5	17,5	SUC 207	P207	0,73
208	93192208	40	49,2	184	137	54	14	18	19,5	99	19	SUC 208	P208	0,93

CAD drawings available on our site
www.chiaravalli.com

Quantity, availability and prices
 on B2B Chiaravalli

