



# SERIE CHS 5 TS

# VITE TRASLANTE

SERIE CHS 5 TS - 10000 daN · TPN 55x9

GRANDEZZA MARTINETTO		CHS 5
PORTATA	daN (Kg)	10000
VITE TPN	DIAMETRO mm PASSO mm	55 9
RIDUZIONE	VELOCE NORMALE LENTA	5:1 10:1 30:1
CORSA VITE PER GIRO mm	VELOCE NORMALE LENTA	1,80 0,90 0,30
RENDIMENTO	VELOCE NORMALE LENTA	19,5% 18,2% 16,9%
PESO MARTINETTO (Kg)		27
PESO VITE TPN X 100 mm (Kg)		1,7
MATERIALE CASSA		G25
QUANTITA' LUBRIFICANTE (Kg)		1,0
TIPO LUBRIFICANTE	AGIP GR MU EP2	
TEMPERATURA ESERCIZIO	-5° C +80° C	

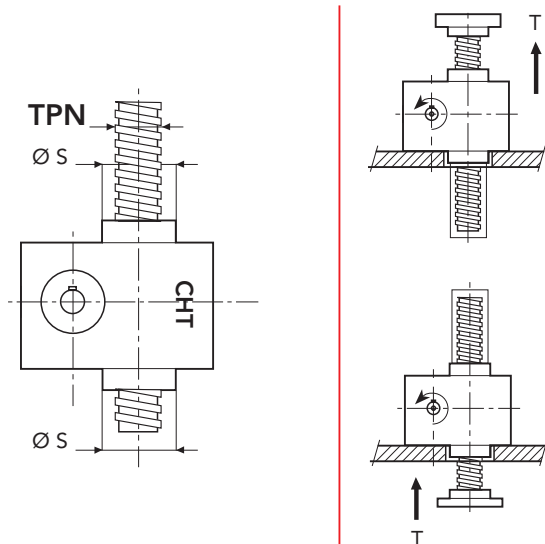
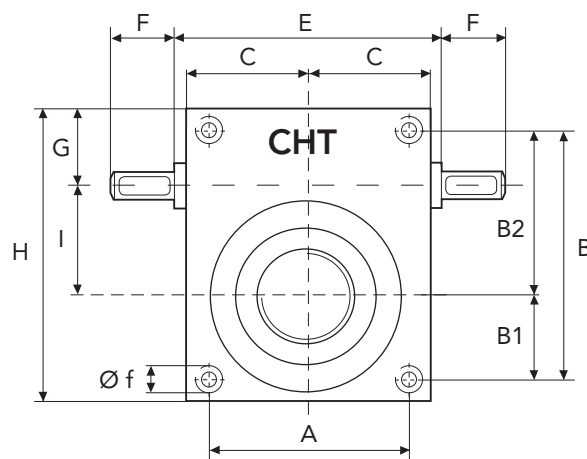
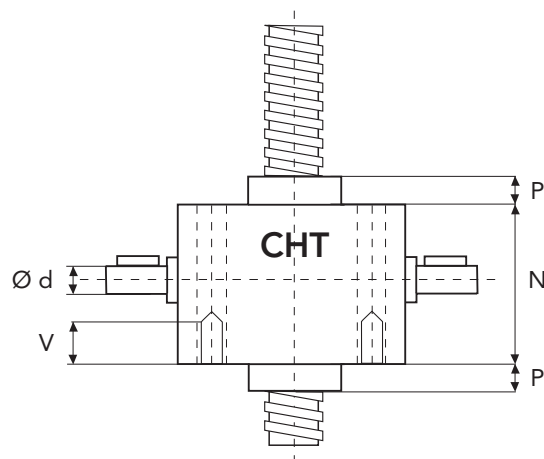

	A	B	B1	B2	C	E	F	G	H
CHS5	134	175	60	115	87,5	-	47,5	68	216
	I	N	P	P1	V	Ø d	Ø f	Ø s	TPN
CHS5	70	150	40	25	40	25	M20	90	55x9

\* fori filettati a richiesta

