

Serie CHQ Series	Diametri prese di forza PTO diameters		Dimensioni forma costruttiva Tipo 9 Type 9 constructive form dimensions																		
	Taglia Size G1	A - D Ø h7	B - C Ø H7	G2 Ø f7	G3	G4	G5	L1	L2	L3	L9	L4	L5	L6	L7	L10	H1	H2	H3	H4	P1
54		11	12	53	8.5	10	52.8	44	23	1.5	72	95	27	190	74	4x4x20	13.8	4	26	M4x10	M4x12
	R	18							35			107		214		6x6x30					
86		16	16	84	15	10	59	70	30	2	84	114	43	228	120	5x5x25	18.3	5	30	M6x12	M8x20
	R	24							50			134		268		8x7x40					
110		20	20	100	15	13	68	90	40	2	110	150	55	300	144	6x6x35	22.8	6	30	M8x20	M10x25
	R	26							55			165		230		8x7x45					
134		24	24	122	18	15	80	114	50	2	132	182	67	364	174	8x7x45	27.3	8	35	M8x20	M10x25
	R	32							65			197		394		10x8x55					
166		32	32	156	21	16	107	144	65	2	152	217	83	434	212	10x8x60	35.3	10	45	M10x25	M12x30
	R	45							90			242		484		14x9x80					
200		42	42	185	23	16	120	174	85	2	182	267	100	534	250	12x8x80	45.3	12	50	M10x25	M14x35
	R	55							110			292		584		16x10x100					
250		55	55	230	22	18	152	216	100	3	218	318	125	636	300	16x10x90	59.3	16	55	M12x25	M16x40
	R	70							140			358		716		20x12x120					
350		65	80	345	30	15	240	320	120	5	330	450	175	900	420	18x11x110	85.4	22	65	M12x25	M20x60
	R	85							170			500		1000		22x14x160					

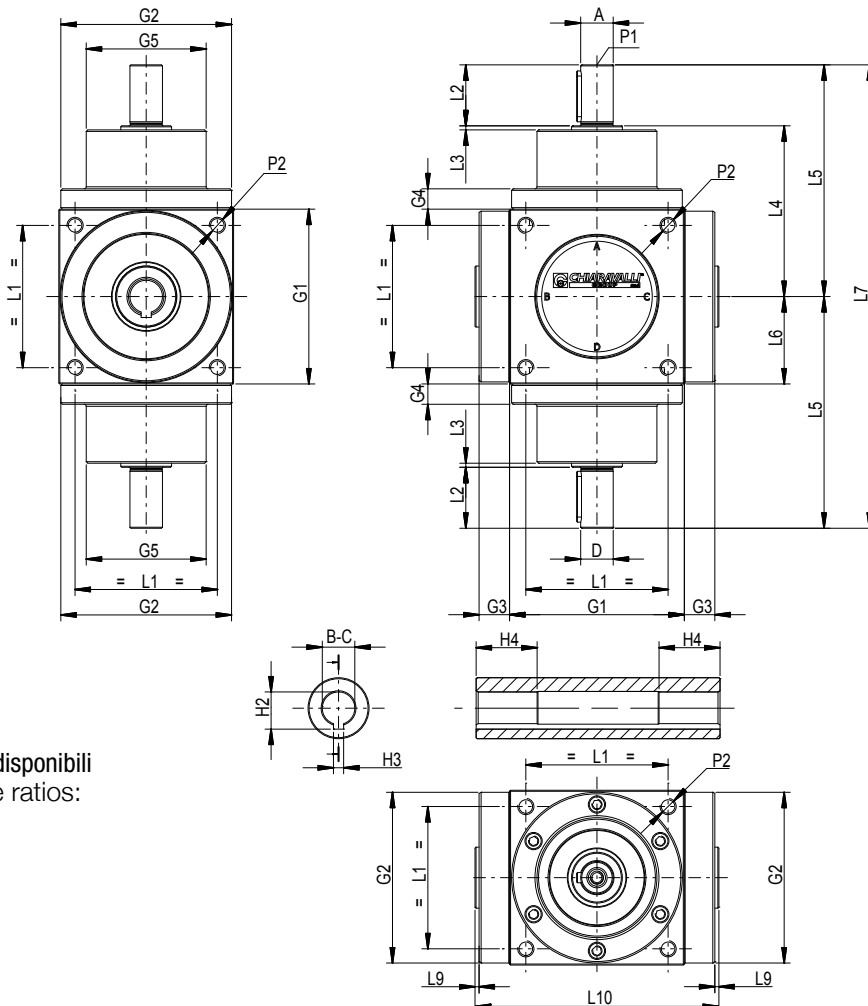

Rapporti disponibili
Available ratios:

- R 1:1
- R 1:1.5
- R 1:2
- R 1:3
- R 1:4

N.B. Il diametro delle prese di forza "A" e "D" è sempre uguale per taglia.
Per esigenze diverse consultare l'Ufficio Tecnico.

NOTE: The diameter of PTO "A" and "D" is the same for size.
For any further information please contact our Technical Dept.



Rotazioni forma costruttiva TIPO 9
TYPE 9 constructive form revolutions