

Serie <b>CHQ</b> Series	Flangia Flange	Diametri prese di forza PTO diameters			Dimensioni Flange PAM PAM Flanges dimensions								
		A Ø h7	G6	G7	G8	L6	L12	H5	H6	H7	H8	H9	P3
<b>86</b>	56 B5	9	120	100	80	43	90	10.4	3	23	4	11	M6
	63 B5	11	140	115	95			12.8	4	23	4	11	M8
	71 B5	14	160	130	110			16.3	5	30	4	11	M8
	71 B14	14	105	85	70			16.3	5	30	4	10	7
	80 B5	19	200	165	130			21.8	6	40	5	11	M10
	80 B14	19	120	100	80			21.8	6	40	5	11	7
<b>110</b>	63 B5	11	140	115	95	55	105	12.8	4	23	4	11	M8
	71 B5	14	160	130	110			16.3	5	30	4	11	M8
	71 B14	14	105	85	70			16.3	5	30	4	11	7
	80 B5	19	200	165	130			21.8	6	40	5	11	M10
	80 B14	19	120	100	80			21.8	6	40	5	11	7
	90 B5	24	200	165	130			27.3	8	50	5	13	M10
<b>134</b>	80 B5	19	200	165	130	67	125	21.8	6	40	5	13	M10
	80 B14	19	120	100	80			21.8	6	40	5	13	7
	90 B5	24	200	165	130			27.3	8	50	5	13	M10
	90 B14	24	140	115	95			27.3	8	50	5	13	9
	100-112 B5	28	250	215	180			31.3	8	60	5	13	M12
	100-112 B14	28	160	130	110			31.3	8	60	5	13	9
<b>166</b>	71 B5	14	160	130	110	83	160	16.3	5	30	4	15	M8
	80 B5	19	200	165	130			21.8	6	40	5	15	M10
	90 B5	24	200	165	130			27.3	8	50	5	15	M10
	100-112 B5	28	250	215	180			31.3	8	60	5	15	M12
	100-112 B14	28	160	130	110			31.3	8	60	5	15	9
	90 B5	24	200	165	130			27.3	8	50	5	23	M10
<b>200</b>	100-112 B5	28	250	215	180	100	220	31.3	8	60	5	23	M12
	132 B5	38	300	265	230			41.3	10	80	6	23	M12
	132 B14	38	200	165	130			41.3	10	80	6	23	11
<b>250</b>	132 B5	38	300	265	230	125	250	41.3	10	80	6	25	M12
	132 B14	38	200	165	130			41.3	10	80	6	25	11
	160 B5	42	350	300	250			45.8	12	110	6	25	M16

Per tutte le dimensioni non quotate fare riferimento alle dimensioni dello schema Tipo 21.  
For all non-quoted dimensions, please refer to those of the Type 21 table.

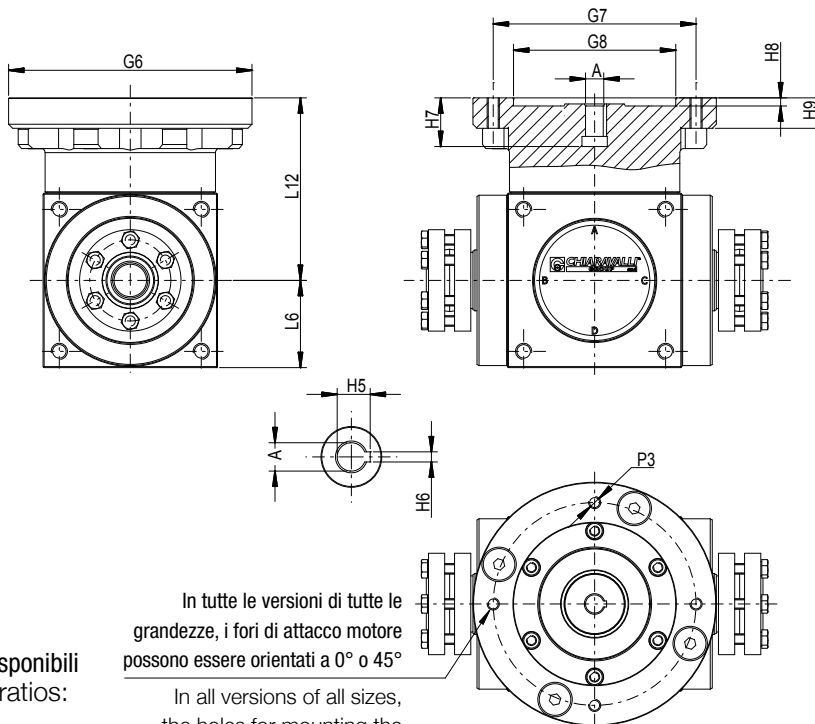

In tutte le versioni di tutte le grandezze, i fori di attacco motore possono essere orientati a 0° o 45°

In all versions of all sizes, the holes for mounting the motors can be oriented at 0° or 45°

Rapporti disponibili  
Available ratios:

- R 1:1
- R 1:1.5
- R 1:2
- R 1:3
- R 1:4

N.B. Il diametro delle prese di forza "B" e "C" è sempre uguale per taglia.  
Per esigenze diverse consultare l'Uff. Tecnico.

NOTE: The diameter of PTO "B" and "C" is the same for size.  
For any further information please contact our Technical Dept.



Rotazioni forma costruttiva TIPO 23  
TYPE 23 constructive form revolutions