



# SERIE CHS 6 TS

# VITE TRASLANTE

SERIE CHS 6 TS - 15000 daN · TPN 60x9

GRANDEZZA MARTINETTO		CHS 6
PORTATA	daN (Kg)	15000
VITE TPN	DIAMETRO mm PASSO mm	60 9
RIDUZIONE	VELOCE NORMALE LENTA	5:1 10:1 30:1
CORSA VITE PER GIRO mm	VELOCE NORMALE LENTA	1,80 0,90 0,30
RENDIMENTO	VELOCE NORMALE LENTA	19,3% 18,0% 16,5%
PESO MARTINETTO (Kg)		29
PESO VITE TPN X 100 mm (Kg)		2
MATERIALE CASSA		G25
QUANTITA' LUBRIFICANTE (Kg)		1
TIPO LUBRIFICANTE	AGIP GR MU EP2	
TEMPERATURA ESERCIZIO	-5° C +80° C	

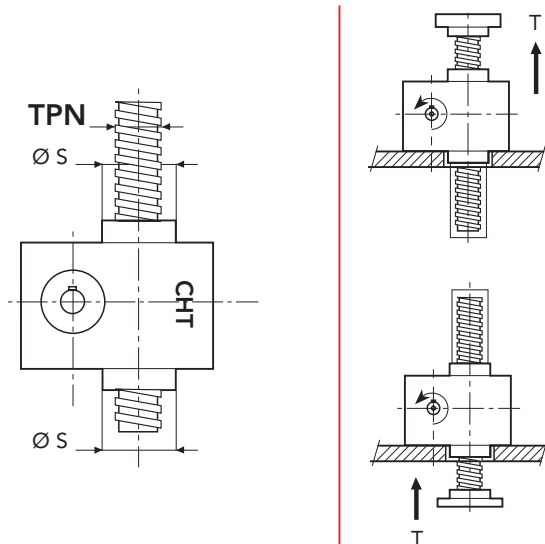
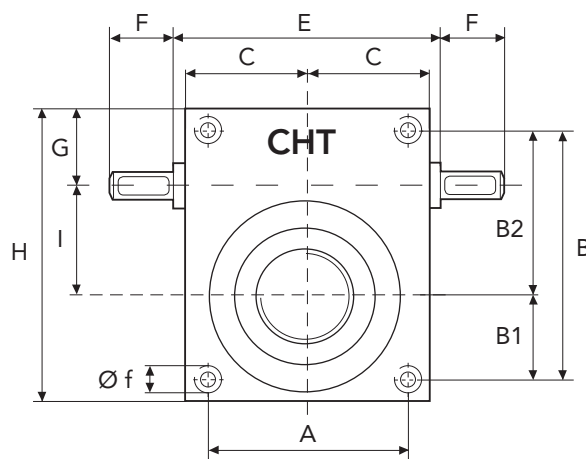
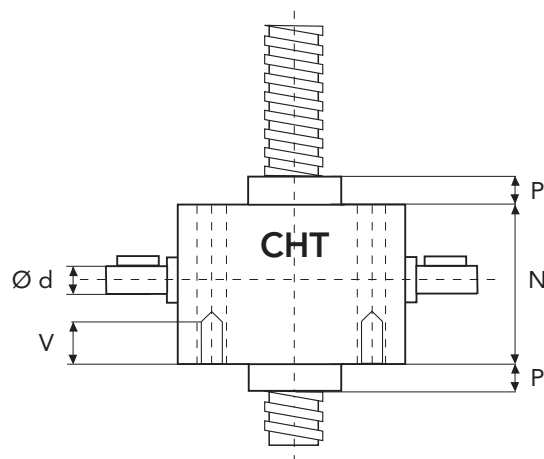

	A	B	B1	B2	C	E	F	G	H
CHS6	134	175	60	115	87,5	-	47,5	68	216
	I	N	P	P1	V	Ø d	Ø f	Ø s	TPN
CHS6	70	150	40	25	40	25	M20	90	60x9

