



SERIE CHS 7 TS

VITE TRASLANTE

SERIE CHS 7 TS - 20000 daN · TPN 70x10

GRANDEZZA MARTINETTO		CHS 7
PORTATA	daN (Kg)	20000
VITE TPN	DIAMETRO mm PASSO mm	70 10
RIDUZIONE	VELOCE NORMALE LENTA	5:1 10:1 30:1
CORSA VITE PER GIRO mm	VELOCE NORMALE LENTA	2 1 0,33
RENDIMENTO	VELOCE NORMALE LENTA	18,5% 17,5% 16%
PESO MARTINETTO (Kg)		54
PESO VITE TPN X 100 mm (Kg)		2,8
MATERIALE CASSA		G25
QUANTITA' LUBRIFICANTE (Kg)		1,5
TIPO LUBRIFICANTE	AGIP GR MU EP2	
TEMPERATURA ESERCIZIO	-5° C +80° C	

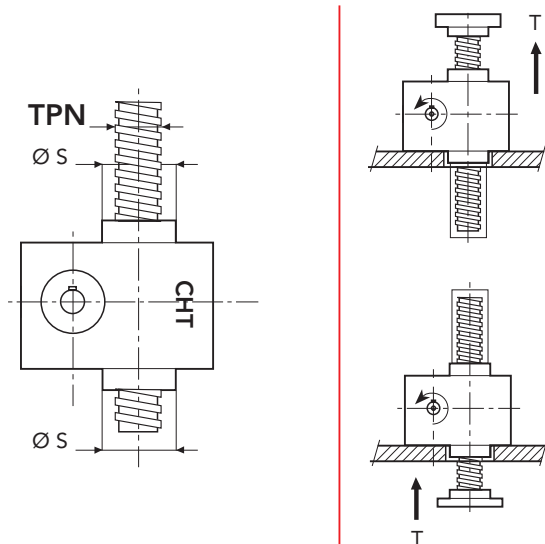
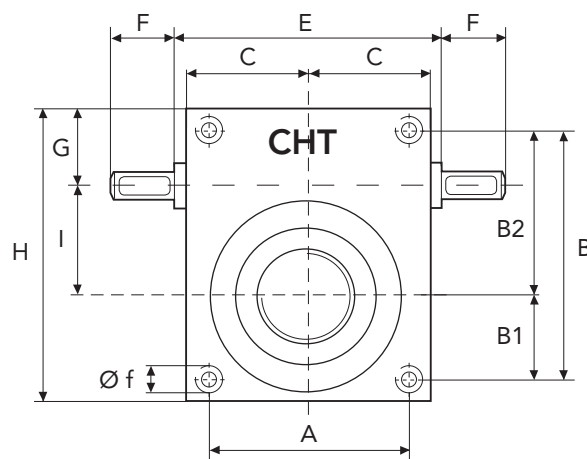
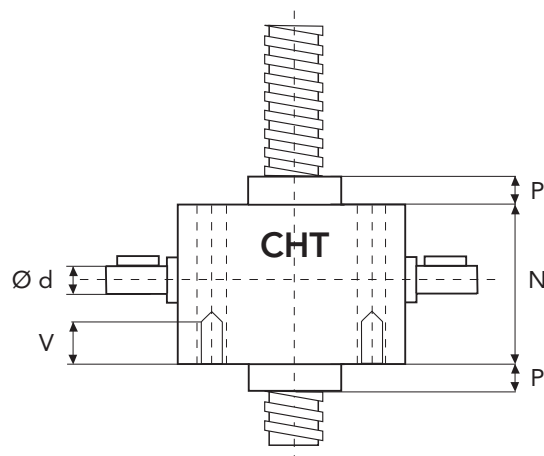

	A	B	B1	B2	C	E	F	G	H
CHS7	180	230	90	140	116	-	60	76	282
	I	N	P	P1	V	Ø d	Ø f	Ø s	TPN
CHS7	90	176	40	30	45	30	M30	120	70x10

