

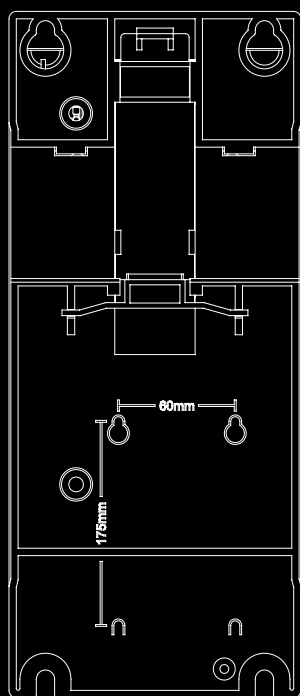

INVERTER CATALOGUE

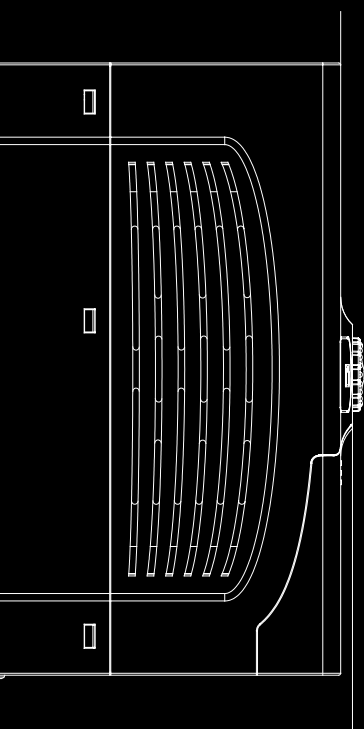



INVERTER GD20

- V/F and Sensorless Vector Control
- External keypad for parameters copy
- Common DC bus solution (400V; $\geq 4\text{kW}$)
- Starting torque up to 0.5Hz/150%
- Built-in DC reactor for inverters $\geq 18.5\text{kW}$
- Built-in braking unit (standard $\leq 37\text{kW}$, optional $\geq 45\text{kW}$)
- Standard C3 filter ($\geq 4\text{kW}$), optional C3 filter ($\leq 2.2\text{kW}$) and C2 Filter



The GD20-EU is a versatile vector control inverter primarily designed for the OEM (Original Equipment Manufacturer) markets.. One of its key features is the certified Safe Torque OFF (STO) function, which enhances safety by ensuring the torque is safely removed from the motor when needed.

This inverter is suitable for a wide range of applications in various industries, including:

- **Water treatment:** The GD20-EU can be used in pumps, mixers, and other equipment involved in water treatment processes.
- **Printing and packaging:** It is applicable to printing presses, packaging machines, and related equipment, offering precise control and high reliability.
- **Winding equipment:** Whether it's for wire winding, coil winding, or other winding processes, this inverter provides smooth operation and precise control.
- **Paper machinery:** It can be utilized in paper cutting, folding, and other processes in the paper industry.
- **Shearing equipment:** The GD20-EU can control motors in shearing machines used in metalworking or other industries.
- **Plastic machinery:** Injection molding machines, extruders, and other plastic processing equipment can benefit from the precise control and safety features of this inverter.
- **Food machinery:** From mixers to conveyors, the inverter can be used in various food processing equipment, ensuring efficiency and safety.
- **Cable machinery:** Whether it's for cable winding, extrusion, or other processes, this inverter provides reliable control for cable manufacturing equipment.
- **Textile machinery:** It can be applied in spinning, weaving, and other textile manufacturing processes, offering precise speed and torque control.
- **HVAC (Heating, Ventilation, and Air Conditioning):** The inverter can control motors in HVAC systems, such as fans and pumps, ensuring energy efficiency and reliable operation.



INSTALLATION

- Side by side installation: In a side-by-side configuration, remove the membranes located at the top of the inverters. This allows for better ventilation and heat dissipation between the inverters.
- Flexible mounting options for inverters ($\leq 2.2\text{kW}$): Inverters with a power rating of 2.2kW or lower support both wall mounting and rail mounting. Choose the mounting option that best suits your installation requirements and space constraints.
- Flexible mounting options for inverters ($\geq 4\text{kW}$): Inverters with a power rating of 4kW or higher support wall mounting and flange mounting. Again, choose the mounting option that fits your installation needs and provides optimal accessibility and stability.

PERFORMANCE

- Vector Control Mode at 50Hz and Full Load: In this scenario, you should see smooth sinusoidal current waveforms with minimal distortion, indicating excellent motor control performance.
- V/F Control Mode at 2Hz and Full Load (Sudden Loading): When suddenly loading in V/F control mode, you may observe a transient spike in current as the motor adjusts to the increased load. The waveform might exhibit some distortion due to the abrupt change in load.
- V/F Control Mode at 2Hz and Full Load (Sudden Unloading): Conversely, when suddenly unloading in V/F control mode, you may see a transient drop in current as the motor reacts to the decreased load. Again, the waveform might exhibit some distortion during this transition.
- Vector Control Mode at 0.5Hz and Full Load (Sudden Loading): Similar to the scenario in V/F control mode, sudden loading in vector control mode might result in a transient spike in current, but the control algorithm should help maintain stability and minimize distortion in the waveform.
- Vector Control Mode at 0.5Hz and Full Load (Sudden Unloading): Similarly, sudden unloading in vector control mode may lead to a transient drop in current, but the control algorithm should help maintain stability and minimize distortion in the waveform. Overall, in vector control mode, you can expect more precise control of the motor, resulting in smoother and more stable current waveforms compared to V/F control mode, especially during sudden changes in load. This demonstrates excellent high-frequency running performance and superior motor drive performance.

MULTI-FUNCTIONALITY AND EASE OF USE

The inverter system offers multiple functions to cater to various industrial needs while ensuring user-friendly operation. This implies that it provides a wide range of capabilities and features to accommodate diverse applications, all while maintaining simplicity in setup and operation.

Built-in DC Reactor for Inverters $\geq 18.5\text{kW}$: A DC reactor helps to smooth the DC voltage and reduce harmonic distortion, enhancing the performance and reliability of the inverter system. Having this reactor built into the inverter for models with a power rating of 18.5kW or higher ensures better power quality and system stability.

Built-in Braking Unit: For inverters with power ratings up to 37kW, a braking unit is included as a standard feature. This braking unit allows for controlled deceleration of the motor and is essential for applications where rapid stopping or braking is required. However, for inverters with higher power ratings (45-110kW), the braking unit is optional, providing flexibility based on specific application requirements.

Common DC Bus Solution for Inverters (400V; $\geq 4\text{kW}$): Inverters with a power rating of 4kW or higher and operating at 400V support the Common DC bus solution. This solution allows multiple inverters to share a common DC bus, enabling energy exchange between them and improving overall system efficiency. It is particularly beneficial in applications where energy regeneration or redistribution is required, such as in regenerative braking systems or multi-drive configurations.



GD20-055G-4-B-EU

Key	No.	Detailed description	Detailed content
Abbreviation	GD20	Product abbreviation	GD20-EU is short for Goodrive20-EU
Rated power	055G	Power range+load type	055-55kW G: constant torque load
Voltage degree	4	Voltage degree	S2: AC 1PH 220V(-15%)~240V(+10%) 2: AC 3PH 220V(-15%)~240V(+10%) 4: AC 3PH 380V(-15%)~440V(+10%)
Additional information 1	B	Braking unit	B: For inverter $\geq 45\text{kW}$ and With "B" assigned, means built-in braking unit.
Additional information 2	EU	Special function	EU: built-in Safe Torque Off function; Without EU, without the function

CHIARAVALLI GROUP

INVERTER GD20 TECHNICAL SPECIFICATION



Function		Specification
Power Input	Input Voltage (V)	1PH 220V (-15%)~240V(+10%) 3PH 220V(-15%)~240V(+10%) 3PH 380V (-15%)~440V(+10%)
	Input Current (A)	Refer to the rated value
	Input Frequency (Hz)	50Hz or 60Hz, allowed range: 47~63Hz
Power Output	Output Motor Capacity (kW)	Refer to the rated value
	Output Current (A)	Refer to the rated value
	Output Voltage (V)	0~input voltage, error<5%
	Output Frequency (Hz)	0~400Hz
Technical Control Feature	Control Mode	SVPWM, SVC
	Adjustable-speed Ratio	1:100
	Speed Control Accuracy	± 0.2% (SVC)
	Speed Fluctuation	± 0.3% (SVC)
	Torque Response	<20ms (SVC)
	Torque Control Accuracy	10%
	Starting Torque	0.5Hz/150% (SVC)
Running Control Feature	Overload Capability	150% of rated current: 1 minute 180% of rated current: 10 seconds 200% of rated current: 1 second
	Frequency Setting Method	Digital setting, analog setting, pulse frequency setting, multi-step speed running setting, simple PLC setting, PID setting, MODBUS communication setting Shift between the set combination and set channel
	Auto-adjustment of the Voltage	Keep a stable voltage automatically when the grid voltage transients
Peripheral Interface	Fault Protection	Provide comprehensive fault protection functions: over-current, over-voltage, under-voltage, over-heating, phase loss and overload, etc.
	Analog Input	1 (AI2) 0~10V/0~20mA and 1 (AI3) -10~10V
	Analog Output	2 (AO1, AO2) 0~10V/0~20mA (Only 1 AO for inverters ≤2.2kW)
	Digital Input	4 common inputs, the Max. frequency: 1kHz; 1 high speed input, the Max. frequency: 50kHz
	Digital Output	1 Y1 terminal output;
Others	Relay Output	2 programmable relay outputs(Only 1 Relay output for inverters ≤2.2kW) RO1A NO, RO1B NC, RO1C common terminal RO2A NO, RO2B NC, RO2C common terminal Contactor capacity: 3A/AC250V
	Mountable Method	Wall and rail mountable
	Braking Unit	≤37kW Standard built-in. 45~110kW Optional built-in (model "-B")
	EMI Filter	Optional filter: meet the degree requirement of IEC61800-3 C2, IEC61800-3 C3
	Temperature of the Running Environment	-10~50°C Above 40°C, derate 1% for every additional 1°C.
	Altitude	<1000m Above 1000m, derate 1% for every additional 100m.
	Protective Degree	IP20
	Safety	Meet the requirement of CE
Cooling	Fan cooling	



CHIARAVALLI GROUP

INVERTER GD20 DATES

Model	Voltage degree	Output power (kW)	Input current (A)	Output current (A)	STO function
GD20-0R4G-S2-EU	1PH 230V	0.4	6.5	2.5	Class SIL2 PLd CAT.3
GD20-0R7G-S2-EU		0.75	9.3	4.2	
GD20-1R5G-S2-EU		1.5	15.7	7.5	
GD20-2R2G-S2-EU		2.2	24	10	
GD20-0R7G-4-EU	3PH 400V	0.75	3.4	2.5	Class SIL2 PLd CAT.3
GD20-1R5G-4-EU		1.5	5.0	4.2	
GD20-2R2G-4-EU		2.2	5.8	5.5	
GD20-004G-4-EU		4	13.5	9.5	Class SIL3 PLe CAT.3
GD20-5R5G-4-EU		5.5	19.5	14	
GD20-7R5G-4-EU		7.5	25	18.5	
GD20-011G-4-EU		11	32	25	
GD20-015G-4-EU		15	40	32	
GD20-018G-4-EU		18.5	47	38	
GD20-022G-4-EU		22	51	45	
GD20-030G-4-EU		30	70	60	
GD20-037G-4-EU		37	80	75	
GD20-045G-4-EU		45	98	92	
GD20-045G-4-B-EU		45	98	92	
GD20-055G-4-EU		55	128	115	
GD20-055G-4-B-EU		55	128	115	
GD20-075G-4-EU		75	139	150	
GD20-075G-4-B-EU		75	139	150	
GD20-090G-4-B-EU		90	168	180	
GD20-090G-4-EU		90	168	180	
GD20-110G-4-EU		110	201	215	
GD20-110G-4-B-EU		110	201	215	

CHIARAVALLI GROUP

INVERTER GD20 DIMENSIONS

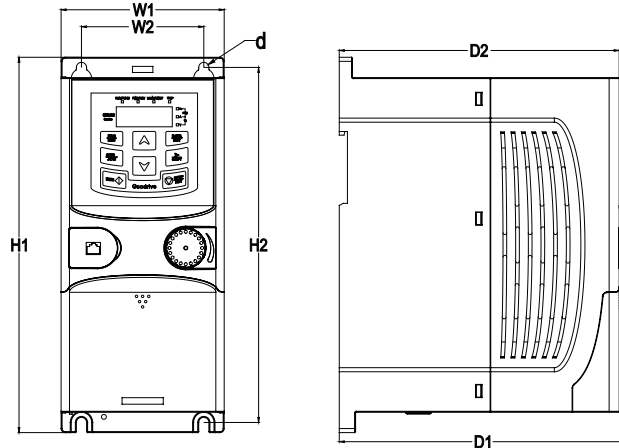

Wall mounting of 0.75~2.2kW inverters

Dimension (unit: mm)

Model	W1	W2	H1	H2	D1	D2	Hole (d)
GD20-0R4G-S2-EU	80.0	60.0	160.0	150.0	123.5	120.3	5
GD20-0R7G-S2-EU	80.0	60.0	160.0	150.0	123.5	120.3	5
GD20-1R5G-S2-EU	80.0	60.0	160.0	175.0	140.5	137.3	5
GD20-2R2G-S2-EU	80.0	60.0	160.0	175.0	140.5	137.3	5
GD20-0R7G-4-EU	80.0	60.0	160.0	175.0	140.5	137.3	5
GD20-1R5G-4-EU	80.0	60.0	160.0	175.0	140.5	137.3	5
GD20-2R2G-4-EU	80.0	60.0	160.0	175.0	140.5	137.3	5

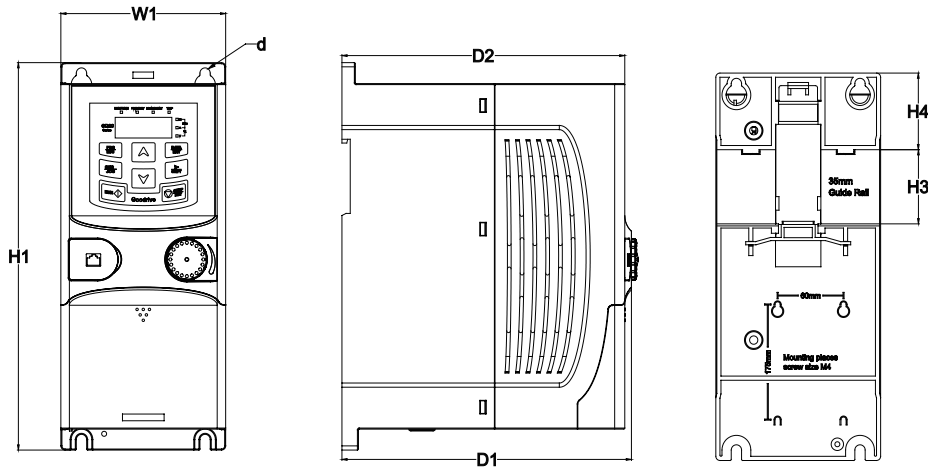

Rail mounting of inverters of 1PH 230V/3PH 380V ($\leq 2.2\text{kW}$) and 3PH 230V ($\leq 0.75\text{kW}$)

Dimension (unit: mm)

Model	W1	W2	H1	H2	D1	D2	Hole (d)
GD20-0R4G-S2-EU	80.0	160.0	35.4	36.6	123.5	120.3	5
GD20-0R7G-S2-EU	80.0	160.0	35.4	36.6	123.5	120.3	5
GD20-1R5G-S2-EU	80.0	185.0	35.4	36.6	140.5	137.3	5
GD20-2R2G-S2-EU	80.0	185.0	35.4	36.6	140.5	137.3	5
GD20-0R7G-4-EU	80.0	185.0	35.4	36.6	140.5	137.3	5
GD20-1R5G-4-EU	80.0	185.0	35.4	36.6	140.5	137.3	5
GD20-2R2G-4-EU	80.0	185.0	35.4	36.6	140.5	137.3	5



CHIARAVALLI GROUP

INVERTER GD20 DIMENSIONS

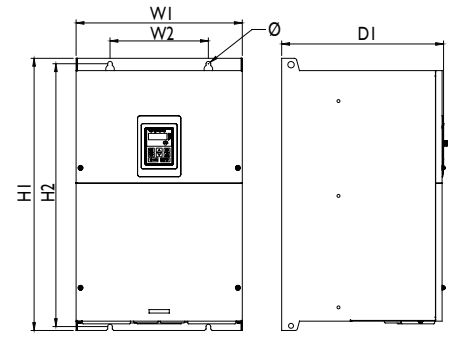
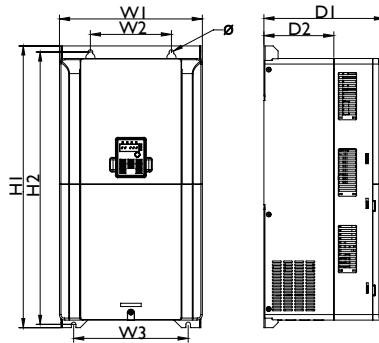
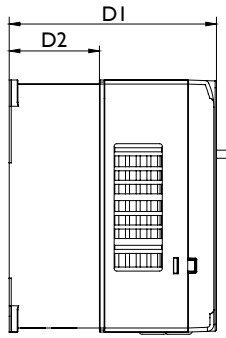
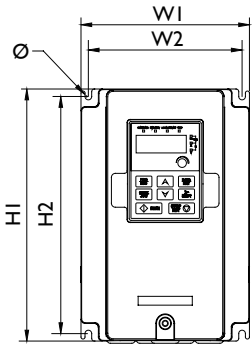

Wall mounting of 3PH 400V 4~37kW
and 7.5 kW inverters

Wall mounting of 3PH 400V
45~75kW inverters

Wall mounting of 3PH 400V
90~110kW inverters

Dimension (unit: mm)

Model	W1	W2	W3	H1	H2	D1	D2	Hole (d)
GD20-004G-4-EU	146.0	131.0	-	256.0	243.5	167.0	84.5	6
GD20-5R5G-4-EU	146.0	131.0	-	256.0	243.5	167.0	84.5	6
GD20-7R5G-4-EU	170.0	151.0	-	320.0	303.5	196.3	113.0	6
GD20-011G-4-EU	170.0	151.0	-	320.0	303.5	196.3	113.0	6
GD20-015G-4-EU	170.0	151.0	-	320.0	303.5	196.3	113.0	6
GD20-018G-4-EU	200.0	185.0	-	340.6	328.6	184.3	104.5	6
GD20-022G-4-EU	200.0	185.0	-	340.6	328.6	184.3	104.5	6
GD20-030G-4-EU	250.0	230.0	-	400.0	380.0	202.0	123.5	6
GD20-037G-4-EU	250.0	230.0	-	400.0	380.0	202.0	123.5	6
GD20-045G-4-EU	282.0	160.0	226.0	560.0	542.0	238.0	138.0	9
GD20-055G-4-EU	282.0	160.0	226.0	560.0	542.0	238.0	138.0	9
GD20-075G-4-EU	282.0	160.0	226.0	560.0	542.0	238.0	138.0	9
GD20-090G-4-EU	338.0	200.0	-	554.0	535.0	329.2	-	9.5
GD20-110G-4-EU	338.0	200.0	-	554.0	535.0	329.2	-	9.5

CHIARAVALLI GROUP

INVERTER GD20 DIMENSIONS

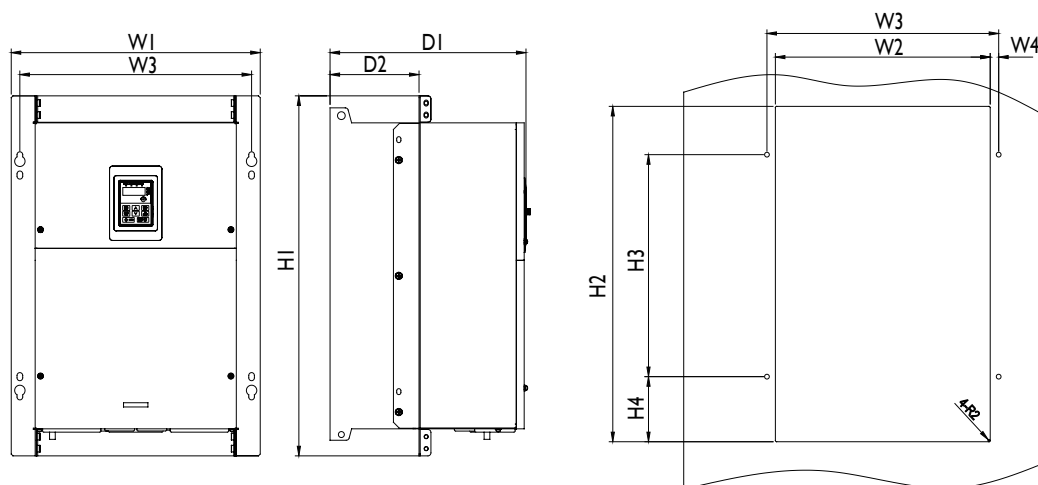

Flange mounting of 3PH 400V 90~110kW inverters

Dimension (unit: mm)

Model	W1	W2	W3	W4	H1	H2	H3	H4	D1	D2	Hole (d)	Nut
GD20-004G-4-EU	170.2	131	150	9.5	292	276	260	6	167	84.5	6	M5
GD20-5R5G-4-EU	170.2	131	150	9.5	292	276	260	6	167	84.5	6	M5
GD20-7R5G-4-EU	191.2	151	174	11.5	370	351	324	12	196.3	113	6	M5
GD20-011G-4-EU	191.2	151	174	11.5	370	351	324	12	196.3	113	6	M5
GD20-015G-4-EU	191.2	151	174	11.5	370	351	324	12	196.3	113	6	M5
GD20-018G-4-EU	266	250	224	13	371	250	350.6	20.3	184.6	104	6	M5
GD20-022G-4-EU	266	250	224	13	371	250	350.6	20.3	184.6	104	6	M5
GD20-030G-4-EU	316	300	274	13	430	300	410	55	202	118.3	6	M5
GD20-037G-4-EU	316	300	274	13	430	300	410	55	202	118.3	6	M5
GD20-045G-4-EU	352	332	306	13	580	400	570	80	238	133.8	9	M8
GD20-055G-4-EU	352	332	306	13	580	400	570	80	238	133.8	9	M8
GD20-075G-4-EU	352	332	306	13	580	400	570	80	238	133.8	9	M8
GD20-090G-4-EU	418.5	361	389.5	14.2	600	559	370	108.5	329.5	149.5	9.5	M8
GD20-110G-4-EU	418.5	361	389.5	14.2	600	559	370	108.5	329.5	149.5	9.5	M8
GD20-022G-4-EU	200.0	185.0	-	340.6	328.6	184.3	184.3	104.5	184.3	104.5	6	184.3
GD20-030G-4-EU	250.0	230.0	-	400.0	380.0	202.0	202.0	123.5	202.0	123.5	6	202.0
GD20-037G-4-EU	250.0	230.0	-	400.0	380.0	202.0	202.0	123.5	202.0	123.5	6	202.0
GD20-045G-4-EU	282.0	160.0	226.0	560.0	542.0	238.0	238.0	138.0	238.0	138.0	9	238.0
GD20-055G-4-EU	282.0	160.0	226.0	560.0	542.0	238.0	238.0	138.0	238.0	138.0	9	238.0
GD20-075G-4-EU	282.0	160.0	226.0	560.0	542.0	238.0	238.0	138.0	238.0	138.0	9	238.0
GD20-090G-4-EU	338.0	200.0	-	554.0	535.0	329.2	329.2	-	329.2	-	9.5	329.2
GD20-110G-4-EU	338.0	200.0	-	554.0	535.0	329.2	329.2	-	329.2	-	9.5	329.2



CHIARAVALLI GROUP

INVERTER GD2 SOFTWARE FUNCTIONS

Function	Used to	Remarks
RS485 communication	Read and modify inverter parameters through connection to the upper computer so as to control inverter running status.	Configured with RS485 communication interface
PID	Carry out PID operation on feedback signals to control inverter output frequency and improve target accuracy and stability. Applicable to pressure, flow and temperature process control.	Supports PID output polarity switching.
Motor parameter autotuning	Carry out rotation or static autotuning, improving control accuracy and response speed.	Classified into rotation autotuning and static autotuning.
Simple PLC function	Change the running frequency and direction automatically according to the running time set by simple PLC to meet process requirements.	Supports multiple running modes.
Multi-step speed control	Meet the speed control requirements in different periods of time.	A maximum of 16 steps can be divided for multi-step speed control.
Multiple V/F curve settings	Meet the requirements of energy-saving operation for fans and water pumps and of various variable frequency power supplies; adapt to different load applications.	Linear, multi-dot, multi-power and V/F separation settings, implementing flexible setting of V/F curves.
Virtual terminals	Take external signals as local virtual I/O to reduce hardware configuration.	Corresponding virtual terminal functions must be enabled in communication mode.
Delay of switching on and off	Provide more programming and control modes	Max. switching on/off delay is 50s
Uninterrupted running in instantaneous power off	Ensure uninterrupted running in instantaneous power off. Especially applicable to the situations with high requirements on continuous operation.	At transient voltage drop, the inverter can keep running by feedback energy without stop in valid time.
Various protection functions	Provide overall fault protection functions.	Various measures provided to protect against faults such as overcurrent, overvoltage, undervoltage, overheating, and overload, whose information can be saved.
Multiple braking modes available	Provide multiple braking modes, satisfying accurate and quick stop under different loads.	DC braking, flux braking, dynamic braking.
Battery capacity display	Display the accumulative power consumption on the inverter without watt-hour meter.	Inverter power consumption can be queried.



C3 AND C2 FILTERS

- Built-in C3 Filters: These filters are incorporated into inverters with certain voltage and power ratings (3-phase; 400V; $\geq 4\text{kW}$ and 3-phase; 230V; $\geq 1.5\text{kW}$). The connection or disconnection of these filters is determined by the J10 configuration.
- External C3 Filters: For inverters with specific voltage and power ratings (single-phase; 230V; $\leq 2.2\text{kW}$, 3-phase; 400V; $\leq 2.2\text{kW}$, and 3-phase; 230V; $\leq 0.75\text{kW}$), external C3 filters can be configured to further enhance EMC performance.
- Optional External C2 Filters: These filters are optional for all GD20-EU series inverters. They are designed to improve EMC performance and meet limited usage requirements in civil environments.

The distinction between C3 and C2 filters lies in their EMC performance standards, with C3 filters catering to industrial environments and C2 filters meeting the requirements for civil environments. The conductive interference test of the power supply terminals ensures compliance with relevant EMC standards and regulations.

EXTERNAL KEYPAD

- Standard Membrane Keypad: Membrane keypads come as standard with inverters operating at 400V with power ratings up to 2.2kW. These keypads provide basic interface functionality for controlling and configuring the inverter. The membrane keypads also support the connection of external LED keypads. This allows users to enhance the functionality and usability of the inverter by adding an external keypad with LED display.
- Use of Higher Power Inverter Keypads: Keypads designed for inverters with a voltage of 400V and power ratings of at least 4kW can serve as external keypads for lower-power inverters. This provides flexibility in keypad options, allowing for compatibility across different models.
- LED Keypad with Data Copy Function: The GD20-EU series inverters can be configured with LED keypads featuring a data copy function. This function enables users to upload or download parameters, simplifying the configuration and setup process of the inverters.

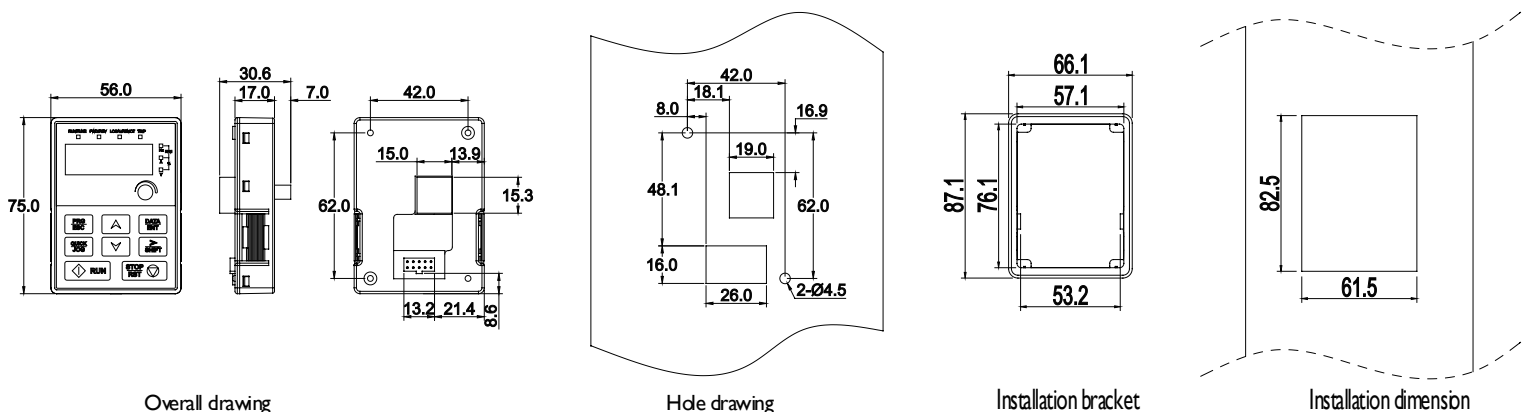

Note: The external keypad can be 20 meters away from the inverter at most.



CHIARAVALLI GROUP

INVERTER GD20 OPTIONAL PARTS



KEYPAD BRACKET

Used for mounting the keypad on the front of the cabinet, providing a secure and convenient location for user interface access.

EXTERNAL LED KEYPAD

This keypad can be added externally to the inverter and may include parameter copying functionality. It provides additional control and configuration options for users.



REACTANCE

Input Reactance: Improves the power factor on the input side of the inverter and helps control higher harmonic currents, enhancing the overall efficiency and stability of the system.

Output Reactance: Extends the effective transmission distance of the inverter and helps control sudden voltage spikes when switching the IGBTs on/off, contributing to smoother operation and protection of the equipment.

FILTER

Input Filter: Controls electromagnetic interference generated from the inverter. It is typically installed close to the input terminals of the inverter to minimize interference in the power supply.

Output Filter: Controls interference from the output side of the inverter and is installed close to the output terminals to reduce electromagnetic interference in connected devices or systems.



BRAKING RESISTOR

This is an auxiliary component for the braking system, used to shorten the deceleration time of the motor and improve control during braking operations.

MEMBRANE OF HEAT RELEASING HOLES AT THE SIDE

Applied in severe environments to improve the protective effect of the inverter. It involves derating the machine by 10% to ensure proper operation and longevity.

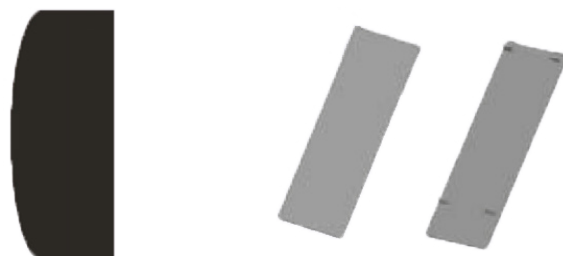

CHIARAVALLI GROUP

INVERTER GD20 STANDARD WIRING

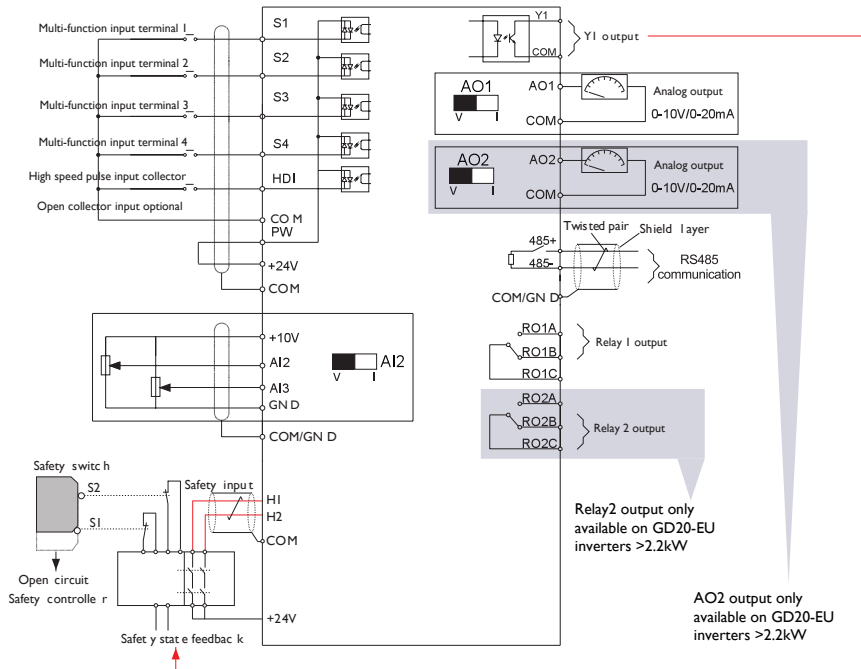

STO input state	Corresponding STO fault
H1, H2 opens simultaneously	Trigger STO function, the drive can't operate normally
H1, H2 closes simultaneously	Don't trigger STO function, the drive can operate normally
Either H1 or H2 opens or closes	Trigger STL1/STL2/STL3 fault, fault code: 38: Safety circuit of channel 1 is abnormal (STL1) 39: Safety circuit of channel 2 is abnormal (STL2) 40: Internal circuit is abnormal (STL3)

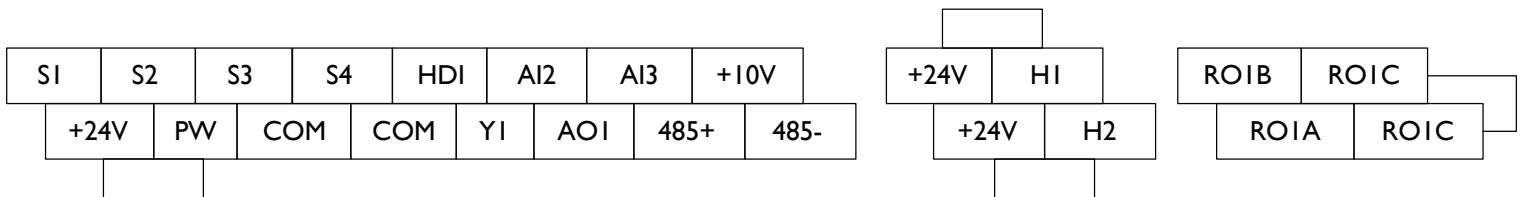

Connection terminal diagram for inverters $\leq 2.2\text{kW}$



Connection terminal diagram for inverters $\geq 4\text{kW}$



INVERTER GD350 MAIN CHARACTERISTICS

- Output frequency 0.0-590Hz
- 400V Versions IP20. On request 200V and 600V and IP55 (400V)
- Vector control with direct I/F sensorless or feedback current control for asynchronous and synchronous motors PM
- Overload max 200% rated current
- Built-in EMC filter C3 on all models
- Integrated braking unit up to and including 37KW
- Safety STO SIL 2
- No. 4 programmable digital inputs
- No. 2 Digital inputs/pulse train 50KHz
- No. 2 Digital outputs, No. 2 relays and No. 1 analog output
- No. 2 analog inputs +/-10Vdc 4/20mA
- Speed, torque and position control
- Dual independent motor parameter sets



The GD350 is a versatile inverter designed to suit a wide range of motors and industrial applications. Using an innovative vector control algorithm, it can handle both asynchronous and synchronous motors, offering advanced torque control features and a built-in positioner.

One of the key features of the GD350 is its flexibility and expansion capability. With built-in expansion slots, fieldbus cards can be added for communication with industrial networks such as Ethernet, CANopen, Profibus, Profinet and EtherCAT.

In addition, various feedback interfaces such as incremental encoders, absolute encoders, and resolvers can be integrated for greater accuracy and control.

The GD350 also offers the ability to add I/O modules to connect external sensors and actuators, an integrated PLC board for additional control logic, and a Bluetooth module for accessing and programming the inverter via a smartphone.

The built-in USB port allows easy and immediate connection to a PC for drive programming and monitoring, giving users a user-friendly interface to manage their industrial applications efficiently.

CHIARAVALLI GROUP

INVERTER GD350 UL VERSION



Characteristic		Specifications UL VERSION								
Line	Model	GD350 - 400V - IP20 - UL VERSION								
3f. 400V	GD350-4-UL	1R5G	2R2G	004G 5R5P	5R5G 7R5P	7R5G 011P	011G 015P	015G 018P	018G 022P	022G 030P
I nom.	load HD (A)	3.7	5.0	9.5	14	18.5	25	32	38	45
Motor	load HD (KW)	1.5	2.2	4.0	5.5	7.5	11	15	18.5	22
I nom.	load ND (A)	-	-	14	18.5	25	32	38	45	60
Motor	load ND (KW)	-	-	5.5	7.5	11	15	18.5	22	30
3f. 400V	GD350-4-UL	030G 037P	037G 045P	045G 055P	055G	075P	075G 090P	090G 110P	110G	132P
I nom.	load HD (A)	60	75	92	115	-	150	180	215	-
Motor	load HD (KW)	30	37	45	55	-	75	90	110	-
I nom.	load ND (A)	75	92	115	-	150	180	215	-	260
Motor	load ND (KW)	37	45	55	-	75	90	110	-	132
3f. 400V	GD350-4-UL	132G 160P	160G 185P	185G 200P	200G 220P	220G 250P	250G 280P	280G 315P	315G 350G	350G 400P
I nom.	load HD (A)	260	305	340	380	425	480	530	600	650
Motor	load HD (KW)	132	160	185	200	220	250	280	315	350
I nom.	load ND (A)	305	340	380	425	480	530	600	650	720
Motor	load ND (KW)	160	185	200	220	250	280	315	350	400
3f. 400V	GD350-4-UL	400G	500P	500G	HEAVY LOAD (HD): 150% for 60s, 180% for 10s, 200% for 1s NORMAL LOAD (ND): 120% for 60s, 150% for 10s, 180% for 1s Check the manual for maximum operating temperatures and PWM frequency values to achieve the indicated current values					
I nom.	load HD (A)	720	-	860						
Motor	load HD (KW)	400	-	500						
I nom.	load ND (A)	-	860	-						
Motor	load ND (KW)	-	500	-						
Power range					400V class: 323-528Vca 50-60Hz.					
Breaking chopper					Integrated up to and including GD350-030G-4. Beyond, optional braking module (standard or regenerative)					
EMC filter					Integrated compatible with EN61800-3 C3					



CHIARAVALLI GROUP

INVERTER GD350 UL VERSION

Voltage class	Motor power HD (KW)	Inverter type	Dimensions (mm)			Mounting
			W width	H height	D depth	
UL VERSION 400V three-phase IP20	1.5	GD350-1R5G-4-UL	126	186	185	Wall mounting
	2.2	GD350-2R2G-4-UL				
	4/5.5	GD350-004G/5R5P-4-UL	146	256	192	
	5.5/7.5	GD350-5R5G/7R5P-4-UL				
	7.5/11	GD350-7R5G/011P-4-UL	170	320	219	
	11/15	GD350-011G/015P-4-UL				
	15/18.5	GD350-015G/018P-4-UL	230	330	217	
	18.5/22	GD350-018G/022P-4-UL				
	22/30	GD350-022G/030P-4-UL	255	400	242	
	30/37	GD350-030G/037P-4-UL				
	37/45	GD350-037G/045P-4-UL	270	55	325	
	45/55	GD350-045G/055P-4-UL				
	55 (HD)	GD350-055G-4-UL	325	680	365	
	75 (ND)	GD350-075P-4-UL				
	75/90	GD350-075G/90P-4-UL	325	680	365	
	90/110	GD350-090G/110P-4-UL				
	110 (HD)	GD350-110G-4-UL	500	870	360	
	132 (ND)	GD350-132P-4-UL				
	132/160	GD350-132G/160P-4-UL	500	870	360	
	160/185	GD350-160G/185P-4-UL				
	185/200	GD350-185G/200P-4-UL	750	1410	380	
	200/220	GD350-200G/220P-4-UL				
	220/250	GD350-220G/250P-4-UL	750	1410	380	
	250/280	GD350-250G/280P-4-UL				
280/315	GD350-280G/315P-4-UL	750	1410	380		
315/350	GD350-315G/350P-4-UL					
350/400	GD350-350G/400P-4-UL	620	1700	560		
400 (HD)	GD350-400G-4-UL					
500 (ND)	GD350-500P-4-UL	620	1700	560		
500 (HD)	GD350-500G-4-UL					



FIRMWARE GD350-19

The GD350-19 is a specialised firmware designed for lifting equipment, which includes a wide range of equipment such as overhead cranes, construction cranes, harbour cranes, conveyor/elevators, gantry cranes and so on.

This firmware has been developed with technical input from leading global companies in the lifting solutions industry, ensuring optimised performance and advanced functionality.

Key features of the GD350-19 firmware include:

Optimised control of motors with conical rotor: This functionality enables precise control even when retrofitting older systems that use motors with conical rotor.

Intelligent brake logic: The firmware includes advanced brake control logic, ensuring effective management of stopping and locking operations.

Automatic speed/load optimisation and electronic load cell: The system can automatically adjust the lifting speed according to the load and integrates an electronic load cell for precise measurement of the weight lifted.

Permanent magnet (PM) synchronous motor control: The firmware supports advanced PM synchronous motor control, offering greater efficiency and energy.

Load-sliding control: This function helps keep the load stable during lifting operations, improving safety and precision.

Master/slave synchronisation control: Allows multiple motors or devices to be coordinated in a synchronised manner for complex lifting operations.

Rotation control for construction cranes: The firmware provides specific control for the rotation of construction cranes, allowing precise and safe movements.

Rope tension control: This feature ensures correct tensioning of the rope during lifting operations, contributing to the safety and durability of the equipment.

FIRMWARE GD350-16

The GD350-16 firmware is designed specifically for pumping systems, adapting to a wide range of applications.

Its features include:

Control of pumps with asynchronous or permanent magnet (PM) synchronous motors: The firmware supports advanced control for both asynchronous and PM synchronous motors, offering flexibility in motor type selection.

Alternation control of up to 4 pumps: This feature enables automatic and sequential control of up to four pumps, ensuring efficient and reliable operation.

Display of setpoint and feedback in the actual unit of measure: The firmware provides a clear and accurate display of setpoint and feedback in the same unit of measure used in the pumping process.

Dual PID controller and differential feedback from dual transducers: This feature enables more accurate pump control through the use of two PID controllers and differential feedback from two transducers, improving system stability and accuracy.

Pump cleaning function: The firmware includes a pump cleaning function, optimising maintenance and ensuring reliable operation over time.

Advanced sleep function: This function reduces the pump's power consumption when not in use, contributing to energy savings and equipment life.









G (Heavy Duty) and P (Normal duty) modes: The firmware offers different operating modes to suit different application needs, ensuring optimal performance in both normal and heavy duty conditions.

Emergency operation mode for fire-fighting systems: The firmware includes a dedicated operation mode for fire-fighting systems, ensuring reliable and fast operation in emergency situations.



CHIARAVALLI GROUP

INVERTER GD350 ACCESSORIES

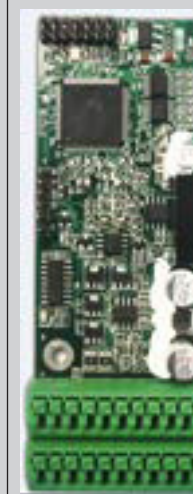
Characteristic	Specifications				
GD350 Integrated Slot Extension Modules					
	Modules I/O		Communication modules		
Code	EC-IO-501-00	EC-TX-508	EC-TX-503	EC-TX-510 EC-TX-515	EC-TX-505
Description	I/O Extension	EtherCAT Module	Profibus Module	Ethernet Modules IP e Modbus TCP	CANOpen Module
GD350 Integrated Slot Expansion Modules					
	Communication modules		feedback tabs		
Code	EC-TX-509	EC-TX-501-1(2)	EC-PG-503-05	EC-PG-505-12	EC-PG504-00
Description	Profinet Module	Bluetooth Module (WIFI module also available)	Encoder Line driver + UVW	incremental Encoder	Resolver



To stay up to date on our current conditions of sale you
can visit our page:

<https://www.chiaravalli.com/en/sales-condition>

Or you can scan the QR Code below:





*Cavaria con Premezzo
21044 - Varese - ITALY
Via per Cedrate, 476 - P.O. 10
Tel. +039 - 0331 214511*

www.chiaravalli.com

