



SERIE CHS 10 TS

VITE TRASLANTE

HEAVY LINE

SERIE CHS 10 TS - 40000 daN · TPN 100x12

GRANDEZZA MARTINETTO		CHS 10
PORTATA	daN (Kg)	40000
VITE TPN	DIAMETRO mm PASSO mm	100 12
RIDUZIONE	NORMALE LENTA	10:1 30:1
CORSA VITE PER GIRO mm	NORMALE LENTA	1,2 0,4
RENDIMENTO	NORMALE LENTA	18,0% 12,5%
PESO MARTINETTO (Kg)		180
PESO VITE TPN X 100 mm (Kg)		5,6
MATERIALE CASSA		Fe 510
QUANTITA' LUBRIFICANTE (Kg)		4
TIPO LUBRIFICANTE	AGIP GR MU EP2	
TEMPERATURA ESERCIZIO	-5° C +80° C	

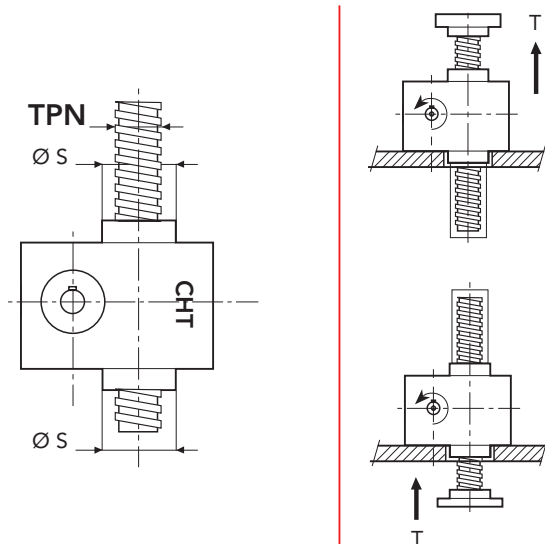
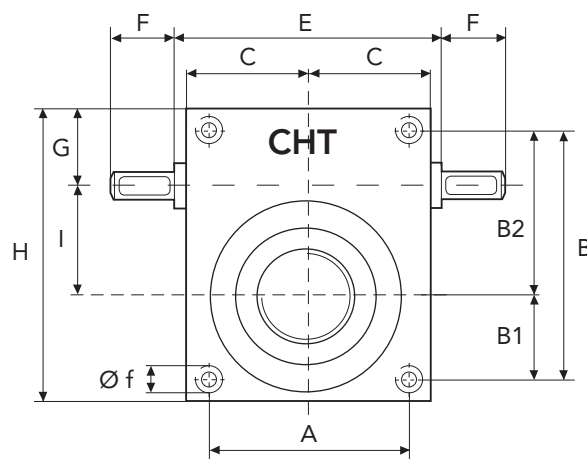
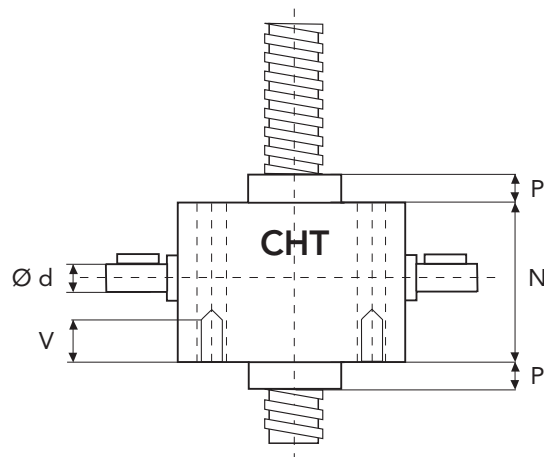

	A	B	B1	B2	C	E	F	G	H
CHS10	230	355	135	220	160	-	85	105	405
	I	N	P	P1	V	Ø d	Ø f	Ø s	TPN
CHS10	140	270	50	40	45	55	M30	210	100x12

