



SERIE CHS 14 TS

VITE TRASLANTE

HEAVY LINE

SERIE CHS 14 TS - 80000 daN · TPN 140x14

GRANDEZZA MARTINETTO		CHS 14
PORTATA	daN (Kg)	80000
VITE TPN	DIAMETRO mm PASSO mm	140 14
RIDUZIONE	NORMALE LENTA	12:1 36:1
CORSA VITE PER GIRO mm	NORMALE LENTA	1,16 0,38
RENDIMENTO	NORMALE LENTA	16,0% 10,0%
PESO MARTINETTO (Kg)		550
PESO VITE TPN X 100 mm (Kg)		11
MATERIALE CASSA		Fe 510
QUANTITA' LUBRIFICANTE (Kg)		14
TIPO LUBRIFICANTE	AGIP GR MU EP2	
TEMPERATURA ESERCIZIO	-5° C +80° C	

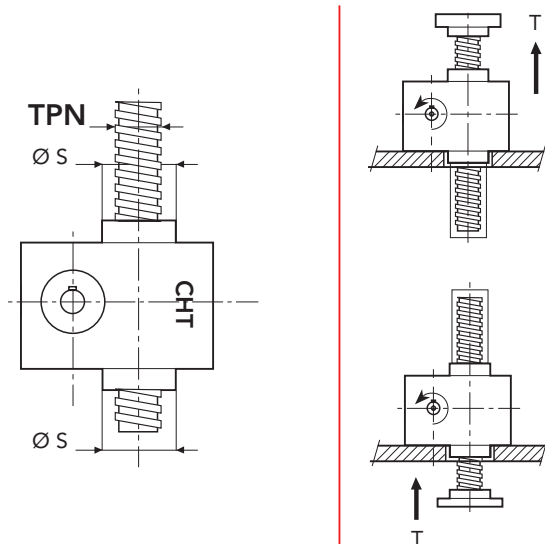
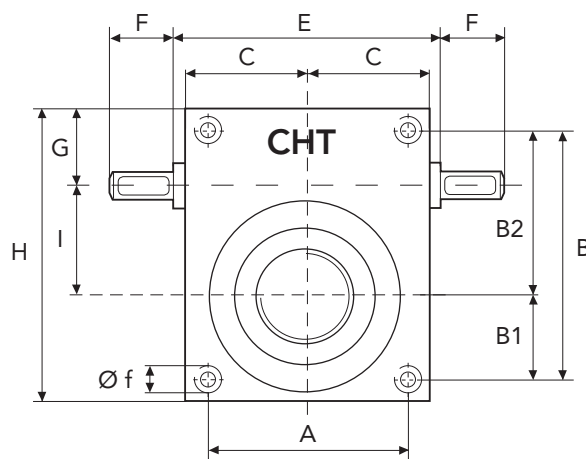
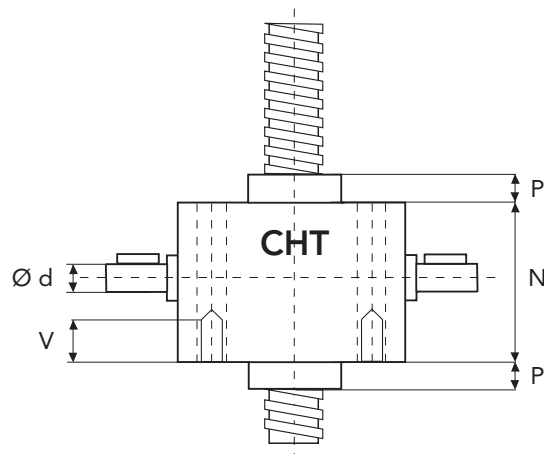

	A	B	B1	B2	C	E	F	G	H
CHS14	360	510	190	320	250	-	140	160	590
	I	N	P	P1	V	Ø d	Ø f	Ø s	TPN
CHS14	200	370	60	50	110	70	M56	300	140x14

