

L = CORSA

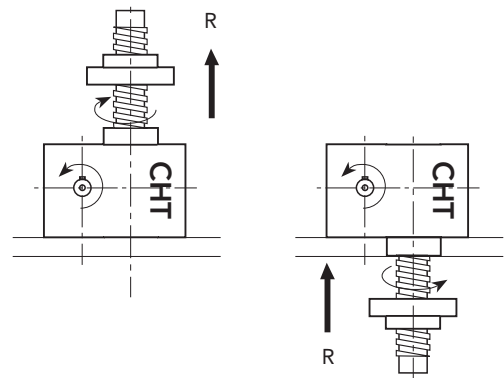

SERIES CHS 8 TS - 25000 daN · TPN 80x10

BRONZE NUT

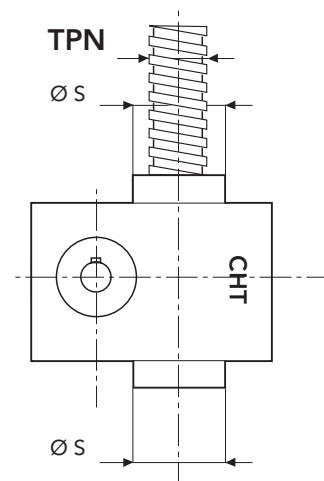
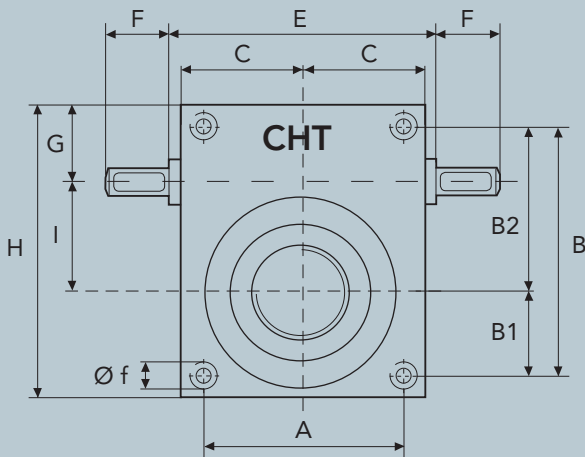
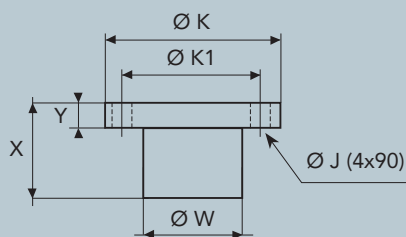

MOTORS ADAPTORS FLANGES

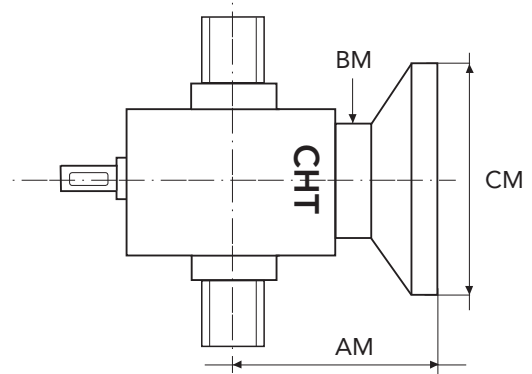

	X	Y	Ø W	Ø K	Ø K1	Ø J
CHS8	110	30	110	190	150	18

MOTOR	FLANGE TYPE	CM	AM	BM
GR. 90	B5	200		
GR. 100/112	B5	250	200	130
	B14	160		
GR. 132	B5	300		
	B14	200		

CONFIGURATION

