

L = CORSA

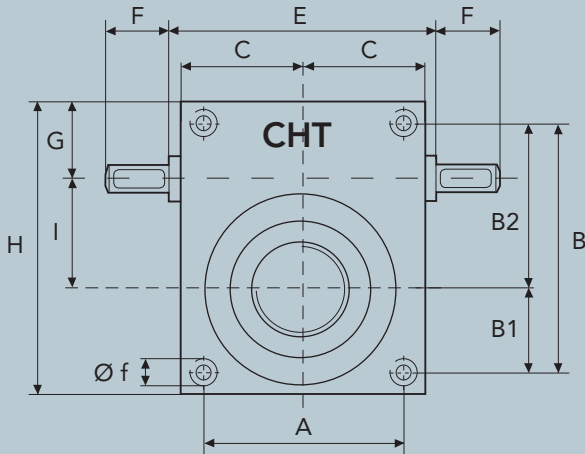

CHIOCCIOLA IN BRONZO

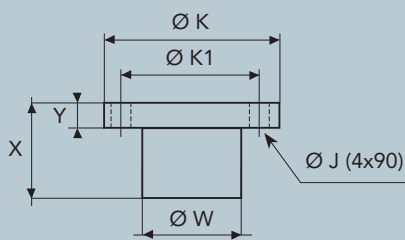

| | X | Y | Ø W | Ø K | Ø K1 | Ø J |
|------|----|----|-----|-----|------|-----|
| CHS1 | 45 | 12 | 26 | 54 | 40 | 7 |

CONFIGURAZIONI

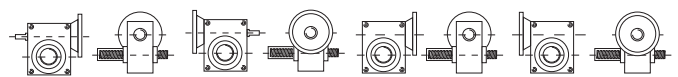

M1

M2

M3

M4

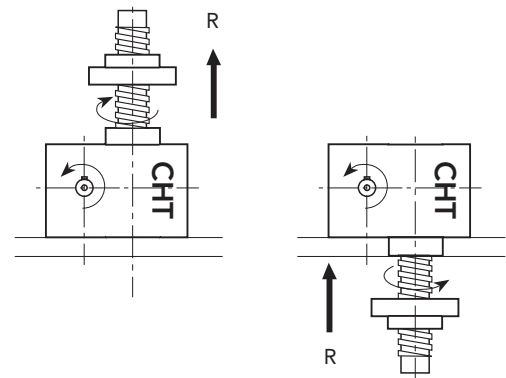
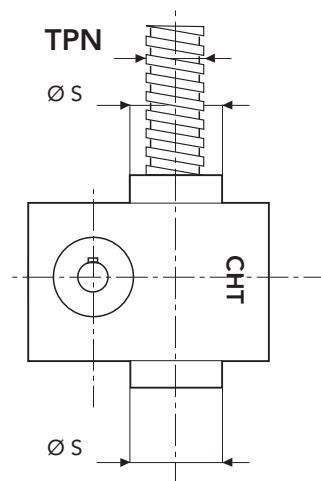

DIMENSIONI PAM CAMPANA E GIUNTO

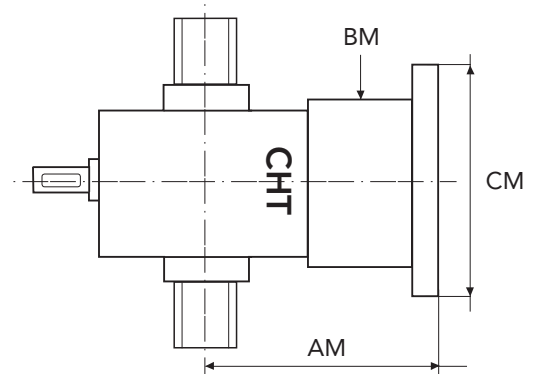

| MOTORE | TIPO FLANGIA | CM | AM | BM |
|--------|--------------|-----|----|----|
| GR. 56 | B5 | 120 | 94 | 49 |
| | B14 | 80 | | |
| GR. 63 | B5 | 140 | 94 | 49 |
| | B14 | 90 | | |

SERIE CHS 1 RS - 500 daN · TPN 18x4