

GEARING DATES	
PITCH	1/2"X5/16"
ROLLER	8.15
Z	17
Ø EXTERNAL	73.61
Ø P	69.12

TAPER-LOCK 1210

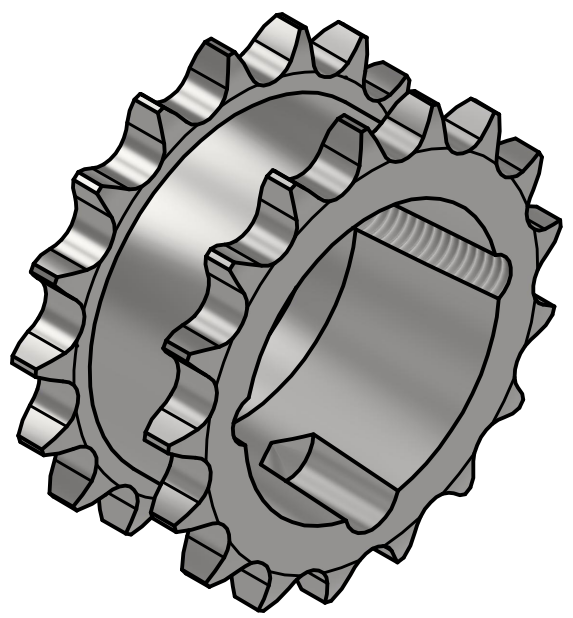

<b>Commenti - Lavorazioni / Comments - Workings</b>		<b>Codice parte / Part code</b> 27212017	<b>Data/Date</b> 30/11/2023
<b>Tolleranze generali di lavorazione / General working tolerance</b> ISO DIN 2768 mK Raggi non quotati R= 0,4 Radius not demensioned R= 0,4 Smussi/Bevel= 0,5 x 45°		<b>Descrizione / Description</b> CORONA T-LOCK 1/2" Z17 X 2 CA	<b>Disegnatore/Drawer</b> P.Silvestro
<b>Materiale/Material:</b> C45		<b>Peso / Weight:</b>	<b>Controllato/Control</b>
<b>Scala:</b>		<b>Dis. Nr./Drw. Nb.</b>	

Tutti i diritti sono riservati. Nessuna parte del disegno può essere riprodotta o comunicata a terzi senza previo consenso scritto dalla CHG S.p.A. All right reserved. No part of this dwg can be reproduced or communicated to third parties without prior written permission by CHG S.p.A.