



# SERIE CHS 1 TS

# VITE TRASLANTE

SERIE CHS 1 TS - 500 daN · TPN 18x4

GRANDEZZA MARTINETTO		CHS 1
PORTATA	daN (Kg)	500
VITE TPN	DIAMETRO mm PASSO mm	18 4
RIDUZIONE	VELOCE NORMALE	5:1 20:1
CORSA VITE PER GIRO mm	VELOCE	0,80
	NORMALE	0,20
RENDIMENTO	VELOCE	25,5%
	NORMALE	23,8%
PESO MARTINETTO (Kg)		2,4
PESO VITE TPN X 100 mm (Kg)		0,16
MATERIALE CASSA		G25
QUANTITA' LUBRIFICANTE (Kg)		0,06
TIPO LUBRIFICANTE	AGIP GR MU EP2	
TEMPERATURA ESERCIZIO	-5° C +80° C	

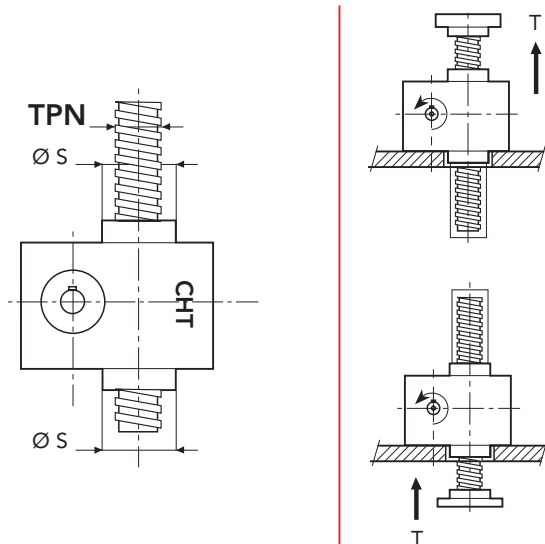
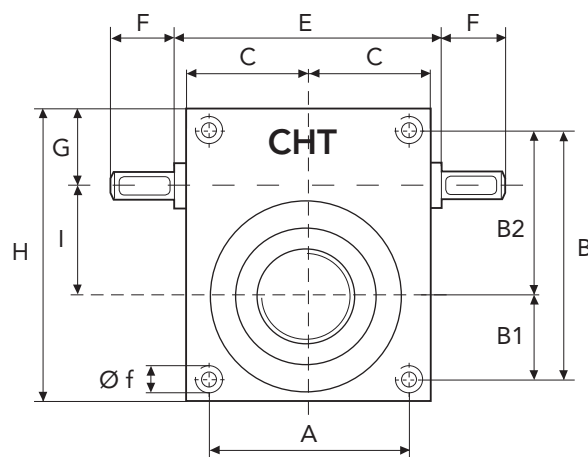
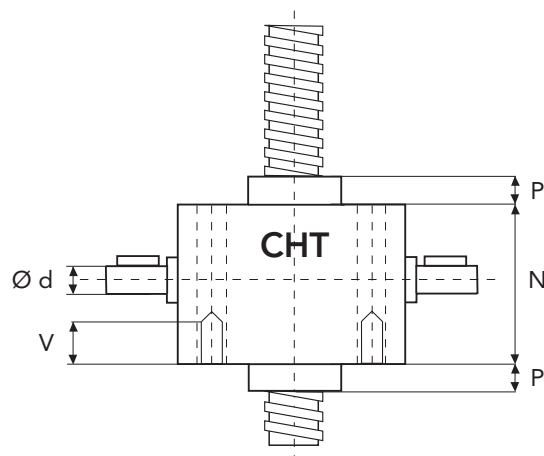

	A	B	B1	B2	C	E	F	G	H
CHS1	56	80	28	52	36	78	20	30	96
	I	N	P	P1	V	Ø d	Ø f	Ø s	TPN
CHS1	30	50	10	15	*	9	8,4	30	18x4

\* fori filettati a richiesta

