

L = CORSA

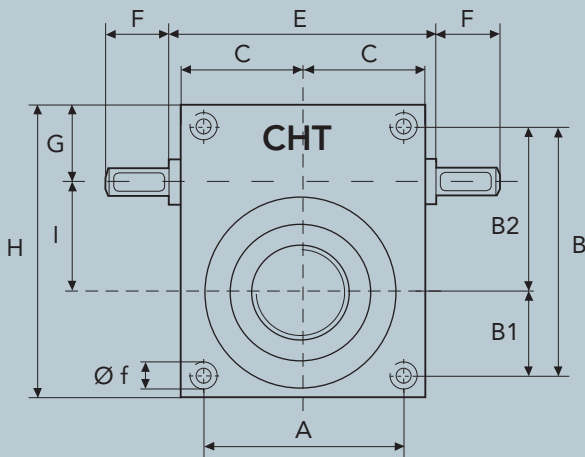

## CHIOCCIOLA IN BRONZO

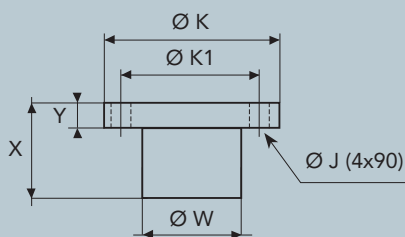

	X	Y	Ø W	Ø K	Ø K1	Ø J
CHS6	120	25	80	110	92	10,5

## CONFIGURAZIONI

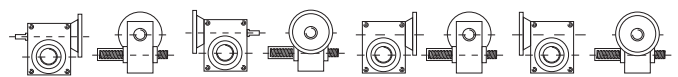

M1

M2

M3

M4

## DIMENSIONI PAM FLANGIA CORTA

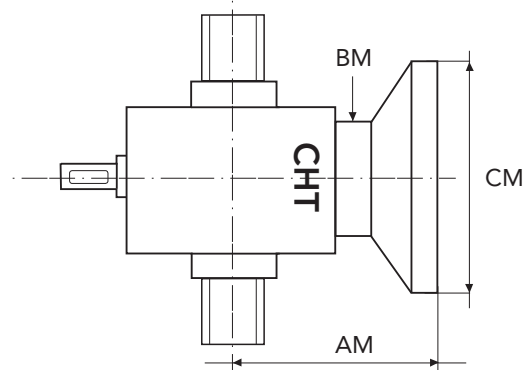

MOTORE	TIPO FLANGIA	CM	AM	BM
GR. 80	B5	200	140	108
	B14	120		
GR. 90	B5	200	140	108
	B14	140		
GR. 100/112	B5	250	140	108
	B14	160		

SERIE CHS 6 TS - 15000 daN · TPN 60x9