



SERIE CHS 16 TS

VITE TRASLANTE

HEAVY LINE

SERIE CHS 16 TS - 100.000 daN · TPN 160x16

GRANDEZZA MARTINETTO		CHS 16
PORTATA	daN (Kg)	100000
VITE TPN	DIAMETRO mm PASSO mm	160 16
RIDUZIONE	NORMALE LENTA	12:1 36:1
CORSA VITE PER GIRO mm	NORMALE LENTA	1,33 0,44
RENDIMENTO	NORMALE LENTA	15,0% 9,0%
PESO MARTINETTO (Kg)		550
PESO VITE TPN X 100 mm (Kg)		14
MATERIALE CASSA		Fe 510
QUANTITA' LUBRIFICANTE (Kg)		14
TIPO LUBRIFICANTE	AGIP GR MU EP2	
TEMPERATURA ESERCIZIO	-5° C +80° C	

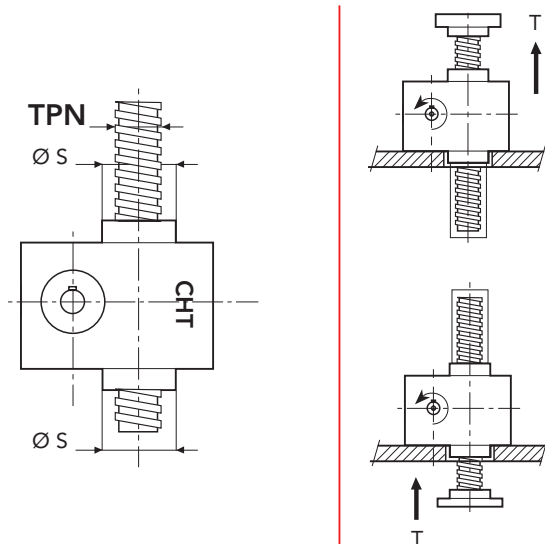
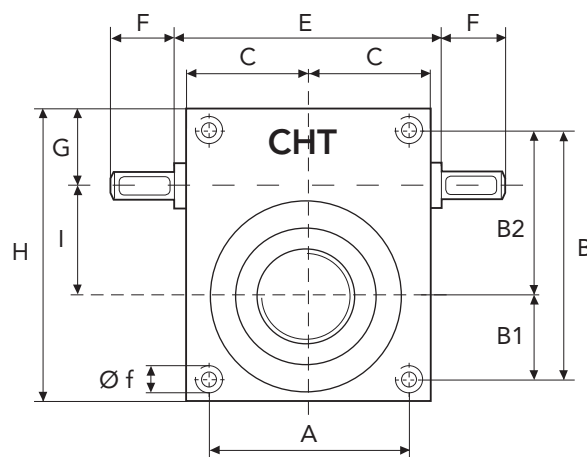
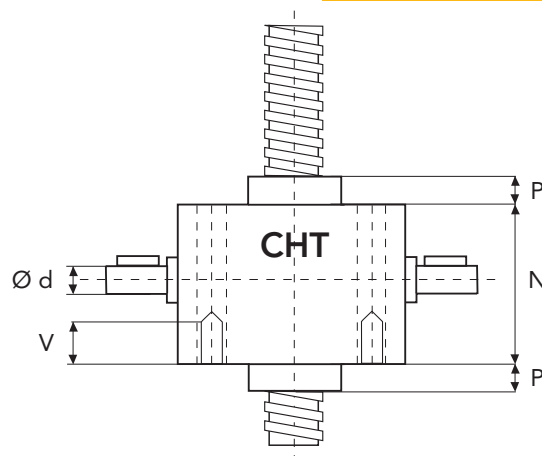

	A	B	B1	B2	C	E	F	G	H
CHS16	360	510	190	320	250	-	140	160	590
	I	N	P	P1	V	Ø d	Ø f	Ø s	TPN
CHS16	200	370	60	50	110	70	M56	300	160x16

