

TEKNİK VERİLER / TECHNICAL DATA / TECHNISCHE DATEN / DATI TECNICI / DONNÉES TECHNIQUES / DATOS TÉCNICAS

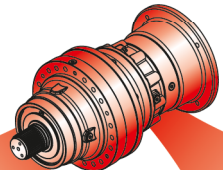

OUTPUT

INPUT

PL

	$i_{ges}$	$M_{max}$ ( $n_2 \times h: 20000$ ) (Nm)
170001	3.83 ... 4.40	346800
170002	15.15 ... 26.40	299800
170003	53.85 ... 178.20	291000
170004	233.72 ... 1291.95	238800
170005	1093.71 ... 8720.66	253600

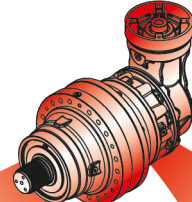
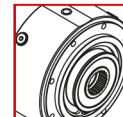
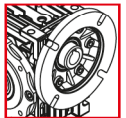
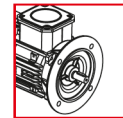
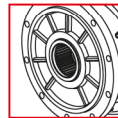
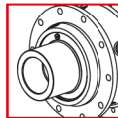
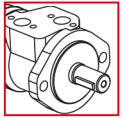
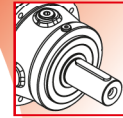
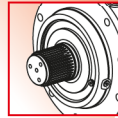
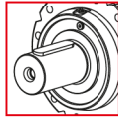

OUTPUT





INPUT

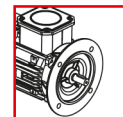
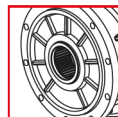
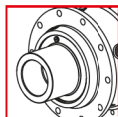
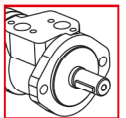
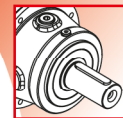
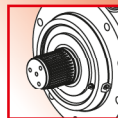
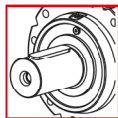

PLB

	$i_{ges}$	$M_{max}$ ( $n_2 \times h: 20000$ ) (Nm)
170003	59.55 ... 123.20	145600
170004	251.31 ... 831.60	238800
170005	1128.60 ... 7033.95	238800

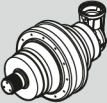

# PL 170000 Nm

	Pt [kW]	n <sub>1max</sub> [min <sup>-1</sup> ]	i <sub>ges</sub>	Mc [kNm]				Giriş- Input - Antrieb - Entrata - Entrée - Entrada				
				n <sub>2</sub> x h	n <sub>2</sub> x h	n <sub>2</sub> x h	n <sub>2</sub> x h					
				10.000	20.000	50.000	100.000	160 180	200 225	250 280		
<b>PL 170001</b>	109	200	3.83 4.40	240.7 208.1	216.8 187.4	188.7 163.1	174.9 153.8	160 180	200 225	250 280	-	-
<b>PL 170002</b>	67	1200	15.15 17.40 19.39 22.28 26.40	205.5 208.1 150.5 168.6 134.5	181.9 187.4 133.1 149.2 119.0	154.8 163.1 113.3 127.0 101.3	137.0 153.6 100.3 112.4 89.7	160 180 200 225 250	-		ET 90	
<b>PL 170003</b>	47	2000	53.85 61.87 74.57 83.10 95.46 108.58 124.74 147.84 178.20	183.3 205.5 179.1 150.5 168.6 149.7 167.9 134.5 134.5	162.3 181.9 158.5 133.1 149.2 132.6 148.6 119.0 119.0	138.0 154.7 134.8 113.3 127.0 112.8 126.5 101.3 101.3	122.2 137.0 119.4 100.3 112.4 99.9 112.0 89.7 89.7	160 180 200 225	110 130 150		EM 65 EM 1"3/8 Z6 EP 65 ET 90	
<b>PL 170004</b>	37	2800	233.72 260.44 326.70 360.64 393.79 429.34 493.23 514.55 572.79 644.49 678.86 748.44 820.29 904.37 1069.20 1291.95	161.0 150.5 168.6 168.6 168.6 150.5 168.6 167.9 150.3 167.9 134.5 167.9 134.5 146.7 134.5 134.5	142.6 133.1 149.2 149.2 149.2 133.1 148.6 148.6 133.2 148.6 119.0 148.6 119.0 129.8 119.0 119.0	121.4 113.3 127.0 127.0 127.0 113.3 126.5 101.3 113.3 126.5 89.7 126.5 101.3 110.4 101.3 101.3	107.4 100.3 112.4 112.4 112.4 100.3 112.4 112.0 100.6 112.0 89.7 112.0 89.7 97.9 89.7 89.7	63 71 80 90 100 112 132 160 180	050 063 075 090 110 130 150		EL C 28 EL C 42 EML 42 EML 1"3/8 Z6 EM 65 EM 1"3/8 Z6 EP 65	
<b>PL 170005</b>	30	2800	1093.71 1207.35 1318.32 1400.14 1545.61 1651.22 1722.60 1829.52 2019.60 2205.23 2404.28 2661.12 2762.10 3329.32 4350.31 5051.97 6104.46 8720.66	171.2 179.1 171.2 168.6 168.6 139.9 138.7 167.9 158.2 168.6 150.5 167.9 168.6 168.6 167.9 167.9 146.7 134.5	151.7 158.5 151.7 149.2 149.2 124.0 122.6 148.6 139.7 149.2 133.1 148.6 149.2 149.2 148.6 148.6 129.8 119.0	129.2 134.8 129.2 127.0 127.0 105.5 104.3 126.5 118.9 127.0 113.3 126.5 127.0 127.0 126.5 126.5 110.4 101.3	114.2 119.4 114.2 112.4 112.4 93.4 92.2 112.0 105.1 112.4 100.3 112.0 112.4 112.1 112.0 97.9 89.7	63 71 80 90 100 112 132 160 180	050 063 075 090		EL C 28 EL C 42 EML 42 EML 1"3/8 Z6	

	Pt [kW]	n <sub>1max</sub> [min <sup>-1</sup> ]	i <sub>ges</sub>	Mc [kNm]				Giriş- Input - Antrieb - Entrada - Entrée - Entrada						
				n <sub>2</sub> x h	n <sub>2</sub> x h	n <sub>2</sub> x h	n <sub>2</sub> x h							
				10.000	20.000	50.000	100.000	IEC (B5)	EL - EML EM - EP - ET					
<b>PLB 170003</b>	42	2500	59.55	90.3	73.3	55.7	45.3	160 180 200 225	EM 65 EM 1"3/8 Z6 EP 65					
			70.58	101.6	82.6	62.7	51.0							
			81.09	112.0	91.0	69.2	56.2							
			90.48	73.8	66.9	50.8	41.2							
			107.24	86.3	75.3	57.2	46.4							
			123.20	97.9	83.0	63.0	51.2							
<b>PLB 170004</b>	35	2500	251.31	163.3	132.6	100.7	81.7	160 180 200	EM 65 EM 1"3/8 Z6 EP 65					
			321.72	150.5	133.1	113.3	97.2							
			383.13	167.9	148.6	126.5	112.0							
			445.50	168.6	149.2	127.0	112.4							
			506.71	149.7	132.6	112.8	99.9							
			582.12	167.9	148.6	126.5	112.0							
			689.92	134.5	119.0	101.3	89.7							
			723.87	120.0	106.2	90.4	80.0							
			831.60	134.5	119.0	101.3	89.7							
			<b>PLB 170005</b>	27	2800	1128.60	168.6			149.2	127.0	112.4	63 71 80 90 100 112 132 160 180	EL C 28 EL C 42 EML 42 EML 1"3/8 Z6 EM 65 EM 1"3/8 Z6 EP 65
						1330.99	139.9			124.0	105.5	93.4		
1417.03	149.7	132.6				112.8	99.9							
1547.27	149.7	132.6				112.8	99.9							
1674.75	143.5	133.9				119.9	97.2							
1777.55	167.9	148.6				126.5	112.0							
1866.23	150.5	133.1				113.3	100.3							
2004.14	137.0	121.3				103.1	91.4							
2226.42	167.9	148.6				126.5	112.0							
2438.54	149.7	132.6				112.8	99.9							
2685.38	168.6	149.2				127.0	112.4							
3054.33	149.7	132.6				112.8	99.9							
4074.84	167.9	148.6				126.5	112.0							
4466.00	134.5	119.0				101.3	89.7							
5821.20	134.5	119.0				101.3	89.7							
7033.95	134.5	119.0	101.3	89.7										



$$M_{\max} = M_C \times 1.6$$

(n<sub>2</sub> x h = 20.000)

# PL/PLB 170000 MS

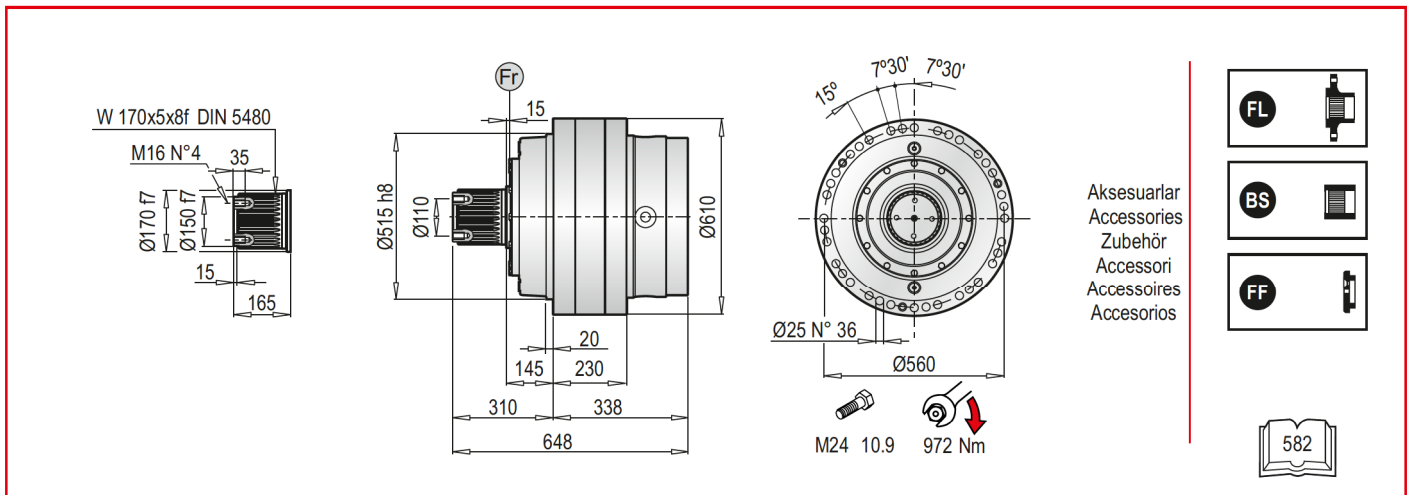

**PL 170000 MS - Elektrik Motor Adaptörleri (IEC) / Electric Motor Couplings (IEC) / Anbauvorrichtung Für Elektromotore (IEC) / Predisposizioni Per Motori Elettrici (IEC) / Adaptations Pour Moteurs Electriques (IEC) / Acoplamientos Para Motores Eléctricos (IEC)**

PL	IEC 63			IEC 71			IEC 80			IEC 90			IEC 100			IEC 112			IEC 132					
	L <sub>T</sub>	Z	ØD	L <sub>T</sub>	Z	ØD	L <sub>T</sub>	Z	ØD	L <sub>T</sub>	Z	ØD	L <sub>T</sub>	Z	ØD	L <sub>T</sub>	Z	ØD	L <sub>T</sub>	Z	ØD			
170001	-	-	-	-	-	-	-	-	-	-	-	-	-	-	-	-	-	-	-	-	-	-	-	-
170002	-	-	-	-	-	-	-	-	-	-	-	-	-	-	-	-	-	-	-	-	-	-	-	-
170003	-	-	-	-	-	-	-	-	-	-	-	-	-	-	-	-	-	-	-	-	-	-	-	-
170004	852	36	140	852	36	160	876	56	200	876	56	200	886	66	250	886	66	250	916	100	300	-	-	-
170005	913	-	-	913	-	-	933	-	-	933	-	-	943	-	-	943	-	-	977	-	-	-	-	-

PL	IEC 160			IEC 180			IEC 200			IEC 225			IEC 250			IEC 280		
	L <sub>T</sub>	Z	ØD	L <sub>T</sub>	Z	ØD	L <sub>T</sub>	Z	ØD	L <sub>T</sub>	Z	ØD	L <sub>T</sub>	Z	ØD	L <sub>T</sub>	Z	ØD
170001	-	150	-	-	150	-	-	150	400	-	139	450	-	139	550	-	139	550
170002	787.5	-	-	787.5	-	-	787.5	-	-	776.5	-	-	776.5	-	-	-	-	-
170003	862.5	118	350	862.5	118	350	892.5	148	-	883.5	-	-	-	-	-	-	-	-
170004	955	139	-	955	139	-	-	-	-	-	-	-	-	-	-	-	-	-
170005	1016	-	-	1016	-	-	-	-	-	-	-	-	-	-	-	-	-	-

PL	IEC ~ Kg												
	63	71	80	90	100	112	132	160	180	200	225	250	280
170001	-	-	-	-	-	-	-	740	740	745	751	763	775
170002	-	-	-	-	-	-	-	967	967	977	983	995	-
170003	-	-	-	-	-	-	-	987	987	997	1007	-	-
170004	990	990	992	992	993	993	997	1007	1007	-	-	-	-
170005	1000	1000	1002	1002	1003	1003	1007	1017	1017	-	-	-	-

**PL 170000 MS - Giriş Milleri / Input Shafts / Antriebswellen / Alberi Entrata / Arbres D'entree / Ejes De Entrada**

PL	EL C 28				EL C 42				EML 42				EML 1"3/8 Z6				EM 65				EM 1"3/8 Z6			
	L <sub>T</sub>	Z	L	Ød	L <sub>T</sub>	Z	L	Ød	L <sub>T</sub>	Z	L	Ød	L <sub>T</sub>	Z	L	Ød	L <sub>T</sub>	Z	L	Ød	L <sub>T</sub>	Z	L	Ød
170002	-	-	-	-	-	-	-	-	-	-	-	-	-	-	-	-	-	-	-	-	-	-	-	-
170003	-	-	-	-	-	-	-	-	-	-	-	-	-	-	-	-	856	121.5	105	65	866	121.5	105	1"3/8
170004	880	64	50	28	880	64	82	42	910	94	82	42	910	94	106	1"3/8	937.5	-	-	-	937.5	-	-	-
170005	941	-	-	-	941	-	-	-	971	-	-	-	971	-	-	-	-	-	-	-	-	-	-	-

PL	EP 65				ET 90				PL	~ Kg							
	L <sub>T</sub>	Z	L	Ød	L <sub>T</sub>	Z	L	Ød		EL C 28	EL C 42	EML 42	EML 1"3/8 Z6	EM 65	EM 1"3/8 Z6	EP 65	ET 90
170002	-	-	-	-	809	171.5	170	90	170002	-	-	-	-	-	-	-	975
170003	897.5	153	105	65	916	-	-	-	170003	-	-	-	-	987	987	996	1018
170004	969	-	-	-	-	-	-	-	170004	990.5	991	994	994	1002	1002	1011	-
170005	-	-	-	-	-	-	-	-	170005	1000.5	1001	1004	1004	-	-	-	-

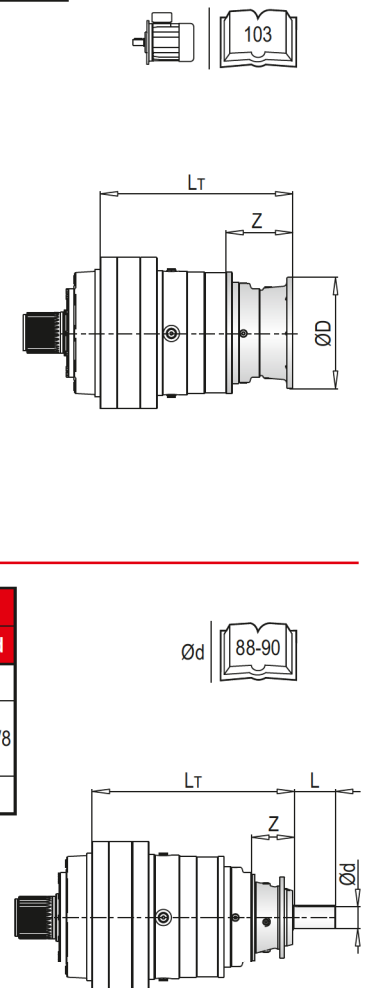

**PL 170000 MS - Sonsuz Dişli Redüktör Adaptörleri (PMRV/PRV) / Worm Gearbox Adaptors (PMRV/PRV) / Anschluss Für Schneckengetriebe (PMRV/PRV) / Predisposizioni Per Riduttori A Vite Senza Fine (PMRV/PRV) / Adaptation Pour Reducteurs A Vis Sans Fin (PMRV/PRV) / Acoplamiento Para Reductores De Tornillo Sin Fin (PMRV/PRV)**

PL	PMRV/PRV 050					PMRV/PRV 063					PMRV/PRV 075				
	Lm	l	h	Ma	G	Lm	l	h	Ma	G	Lm	l	h	Ma	G
170003	-					-					-				
170004	937.5	50	110	60	80	947	63	113	72	95	926	75	161	86	112.5
170005	998.5					1008					987				

PL	PMRV/PRV 090					PMRV/PRV 110					PMRV/PRV 130				
	Lm	l	h	Ma	G	Lm	l	h	Ma	G	Lm	l	h	Ma	G
170003	-					878.5	110	237.5	127.5	160	884	130	277.5	147.5	180
170004	936	90	193	103	129.5	950					955.5				
170005	997					-					-				

PL	PMRV/PRV 150				
	Lm	l	h	Ma	G
170003	900.5	150	320	170	210
170004	972				
170005	-				

PL	PMRV/PRV ~ Kg						
	050	063	075	090	110	130	150
170003	-	-	-	-	1016	1033	1069
170004	993	996.5	999	1004	1031	1048	1084
170005	1003	1006.5	1009	1013	-	-	-

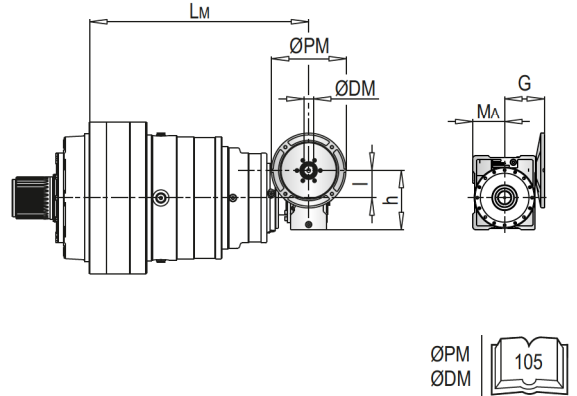

**PLB 170000 MS - Elektrik Motor Adaptörleri (IEC) / Electric Motor Couplings (IEC) / Anbauvorrichtung Für Elektromotore (IEC) / Predisposizioni Per Motori Elettrici (IEC) / Adaptations Pour Moteurs Electriques (IEC) / Acoplamientos Para Motores Eléctricos (IEC)**

PLB	IEC 63				IEC 71				IEC 80				IEC 90				IEC 100				IEC 112			
	A	Lt	Z	ØD	A	Lt	Z	ØD	A	Lt	Z	ØD	A	Lt	Z	ØD	A	Lt	Z	ØD	A	Lt	Z	ØD
170003	-				-				-				-				-							
170004	-				-				-				-				-							
170005	917.5	276	36	140	917.5	276	36	160	917.5	296	56	200	917.5	296	56	200	917.5	306	66	250	917.5	306	66	250

PLB	IEC 132				IEC 160				IEC 180				IEC 200				IEC 225			
	A	Lt	Z	ØD	A	Lt	Z	ØD	A	Lt	Z	ØD	A	Lt	Z	ØD	A	Lt	Z	ØD
170003	-				818.5	433	118	350	818.5	433	118	350	818.5	463	148	400	818.5	454	139	450
170004	-				879.5				879.5				879.5				-			
170005	917.5	340	100	300	917.5	358	139		917.5	358	139		-			-				

PLB	IEC ~ Kg										
	63	71	80	90	100	112	132	160	180	200	225
170003	-	-	-	-	-	-	-	1032	1032	1042	1047
170004	-	-	-	-	-	-	-	1065	1065	1075	-
170005	1033	1033	1035	1035	1036	1036	1040	1050	1050	-	-

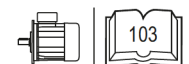
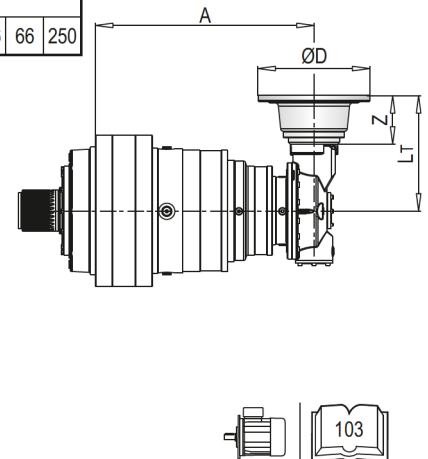

**PLB 170000 MS - Giriş Milleri / Input Shafts / Antriebswellen / Alberi Entrata / Arbres D'entree / Ejes De Entrada**

PLB	EL C 28					EL C 42					EML 42					EML 1"3/8 Z6					EM 65				
	A	Lt	Z	L	Ød	A	Lt	Z	L	Ød	A	Lt	Z	L	Ød	A	Lt	Z	L	Ød	A	Lt	Z	L	Ød
170003	-					-					-					-					818.5	436.5	121.5	105	65
170004	-					-					-					-					879.5				
170005	917.5	304	64	50	28	917.5	304	64	82	42	917.5	334	94	82	42	917.5	334	94	106	1"3/8	917.5	361.5			

PLB	EM 1"3/8 Z6					EP 65				
	A	Lt	Z	L	Ød	A	Lt	Z	L	Ød
170003	818.5	436.5	121.5	105	1"3/8	818.5	468	153	105	65
170004	879.5					879.5				
170005	917.5	361.5				917.5	393			

PLB	~ Kg						
	EL C 28	EL C 42	EML 42	EML 1"3/8 Z6	EM 65	EM 1"3/8 Z6	EP 65
170003	-	-	-	-	1027	1027	1036
170004	-	-	-	-	1060	1060	1069
170005	1033.5	1034	1037	1037	1045	1045	1054

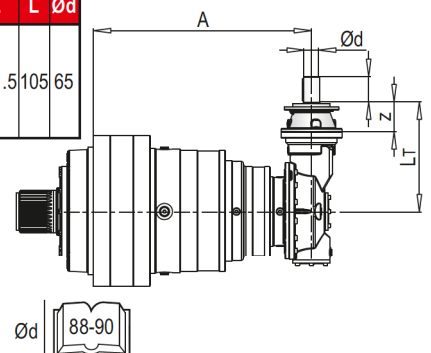

# PL/PLB 170000 MC

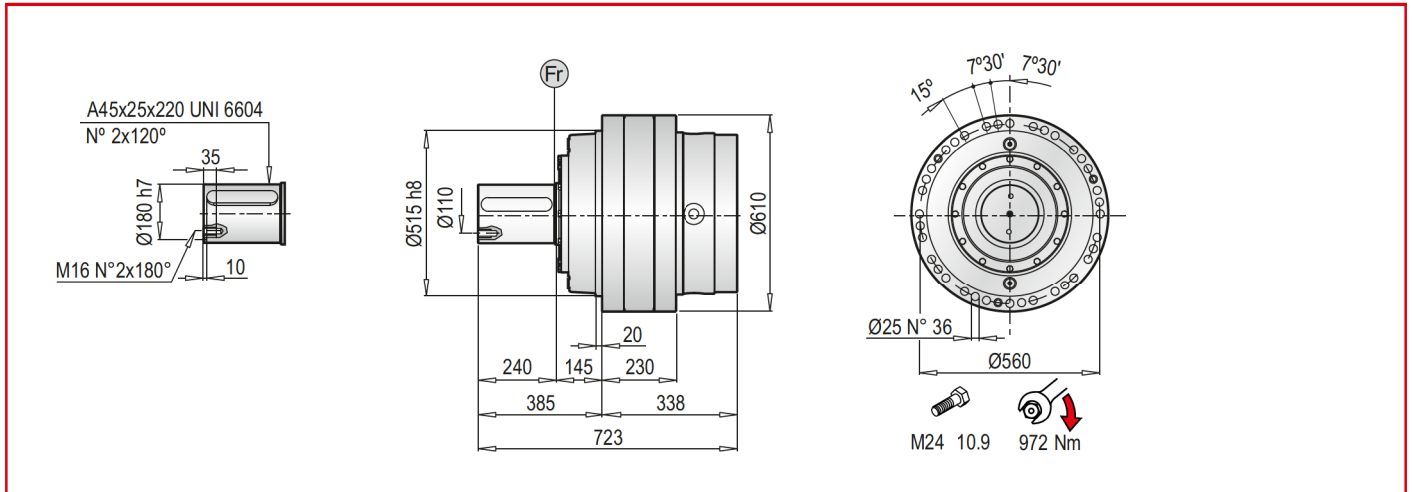

**PL 170000 MC** - Elektrik Motor Adaptörleri (IEC) / Electric Motor Couplings (IEC) / Anbauvorrichtung Für Elektromotore (IEC) / Predisposizioni Per Motori Elettrici (IEC) / Adaptations Pour Moteurs Electriques (IEC) / Acoplamientos Para Motores Eléctricos (IEC)

PL	IEC 63			IEC 71			IEC 80			IEC 90			IEC 100			IEC 112			IEC 132					
	L <sub>T</sub>	Z	ØD	L <sub>T</sub>	Z	ØD	L <sub>T</sub>	Z	ØD	L <sub>T</sub>	Z	ØD	L <sub>T</sub>	Z	ØD	L <sub>T</sub>	Z	ØD	L <sub>T</sub>	Z	ØD			
170001	-	-	-	-	-	-	-	-	-	-	-	-	-	-	-	-	-	-	-	-	-	-	-	-
170002	-	-	-	-	-	-	-	-	-	-	-	-	-	-	-	-	-	-	-	-	-	-	-	-
170003	-	-	-	-	-	-	-	-	-	-	-	-	-	-	-	-	-	-	-	-	-	-	-	-
170004	852	36	140	852	36	160	876	56	200	876	56	200	886	66	250	886	66	250	916	100	300	-	-	-
170005	913	-	-	913	-	-	933	-	-	933	-	-	943	-	-	943	-	-	977	-	-	-	-	-

PL	IEC 160			IEC 180			IEC 200			IEC 225			IEC 250			IEC 280		
	L <sub>T</sub>	Z	ØD	L <sub>T</sub>	Z	ØD	L <sub>T</sub>	Z	ØD	L <sub>T</sub>	Z	ØD	L <sub>T</sub>	Z	ØD	L <sub>T</sub>	Z	ØD
170001	-	150	-	-	150	-	-	150	400	-	139	450	-	139	550	-	139	550
170002	787.5	-	-	787.5	-	-	787.5	-	-	776.5	-	-	776.5	-	-	-	-	-
170003	862.5	118	350	862.5	118	350	892.5	148	-	883.5	-	-	-	-	-	-	-	-
170004	955	-	-	955	-	-	-	-	-	-	-	-	-	-	-	-	-	-
170005	1016	139	-	1016	139	-	-	-	-	-	-	-	-	-	-	-	-	-

PL	IEC ~ Kg												
	63	71	80	90	100	112	132	160	180	200	225	250	280
170001	-	-	-	-	-	-	-	740	740	745	751	763	775
170002	-	-	-	-	-	-	-	967	967	977	983	995	-
170003	-	-	-	-	-	-	-	987	987	997	1007	-	-
170004	990	990	992	992	993	993	997	1007	1007	-	-	-	-
170005	1000	1000	1002	1002	1003	1003	1007	1017	1017	-	-	-	-

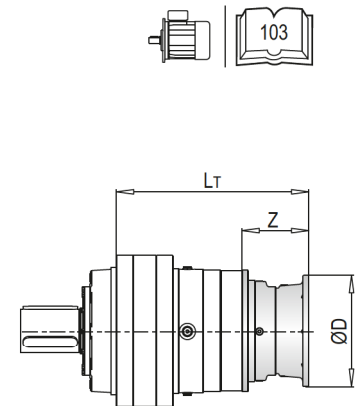

**PL 170000 MC** - Giriş Milleri / Input Shafts / Antriebswellen / Alberi Entrata / Arbres D'entree / Ejes De Entrada

PL	EL C 28				EL C 42				EML 42				EML 1"3/8 Z6				EM 65				EM 1"3/8 Z6			
	L <sub>T</sub>	Z	L	Ød	L <sub>T</sub>	Z	L	Ød	L <sub>T</sub>	Z	L	Ød	L <sub>T</sub>	Z	L	Ød	L <sub>T</sub>	Z	L	Ød	L <sub>T</sub>	Z	L	Ød
170002	-	-	-	-	-	-	-	-	-	-	-	-	-	-	-	-	-	-	-	-	-	-	-	-
170003	-	-	-	-	-	-	-	-	-	-	-	-	-	-	-	-	856	121.5	105	65	866	121.5	105	1"3/8
170004	880	64	50	28	880	64	82	42	910	94	82	42	910	94	106	1"3/8	937.5	-	-	-	937.5	-	-	-
170005	941	-	-	-	941	-	-	-	971	-	-	-	971	-	-	-	-	-	-	-	-	-	-	-

PL	EP 65				ET 90				PL	~ Kg							
	L <sub>T</sub>	Z	L	Ød	L <sub>T</sub>	Z	L	Ød		EL C 28	EL C 42	EML 42	EML 1"3/8 Z6	EM 65	EM 1"3/8 Z6	EP 65	ET 90
170002	-	-	-	-	809	171.5	170	90	170002	-	-	-	-	-	-	-	975
170003	897.5	153	105	65	916	-	-	-	170003	-	-	-	-	987	987	996	1018
170004	969	-	-	-	-	-	-	-	170004	990.5	991	994	994	1002	1002	1011	-
170005	-	-	-	-	-	-	-	-	170005	1000.5	1001	1004	1004	-	-	-	-

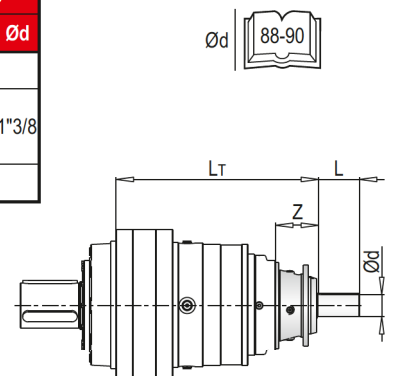

**PL 170000 MC** - Sonsuz Dişlili Redüktör Adaptörleri (PMRV/PRV) / Worm Gearbox Adaptors (PMRV/PRV) / Anschluss Für Schneckengetriebe (PMRV/PRV) / Predisposizioni Per Riduttori A Vite Senza Fine (PMRV/PRV) / Adaptation Pour Reducteurs A Vis Sans Fin (PMRV/PRV) / Acoplamiento Para Reductores De Tornillo Sin Fin (PMRV/PRV)

PL	PMRV/PRV 050					PMRV/PRV 063					PMRV/PRV 075				
	Lm	l	h	MA	G	Lm	l	h	MA	G	Lm	l	h	MA	G
170003	-														
170004	937.5	50	110	60	80	947	63	113	72	95	926	75	161	86	112.5
170005	998.5					1008					987				

PL	PMRV/PRV 090					PMRV/PRV 110					PMRV/PRV 130				
	Lm	l	h	MA	G	Lm	l	h	MA	G	Lm	l	h	MA	G
170003	-														
170004	936	90	193	103	129.5	878.5	110	237.5	127.5	160	884	130	277.5	147.5	180
170005	997					950					955.5				

PL	PMRV/PRV 150				
	Lm	l	h	MA	G
170003	900.5	150	320	170	210
170004	972				
170005	-				

PL	PMRV/PRV ~ Kg						
	050	063	075	090	110	130	150
170003	-	-	-	-	1016	1033	1069
170004	993	996.5	999	1004	1031	1048	1084
170005	1003	1006.5	1009	1013	-	-	-

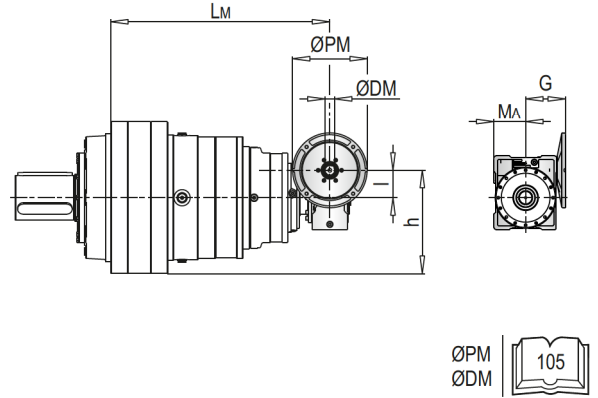

**PLB 170000 MC** - Elektrik Motor Adaptörleri (IEC) / Electric Motor Couplings (IEC) / Anbauvorrichtung Für Elektromotore (IEC) / Predisposizioni Per Motori Elettrici (IEC) / Adaptations Pour Moteurs Electriques (IEC) / Acoplamientos Para Motores Eléctricos (IEC)

PLB	IEC 63				IEC 71				IEC 80				IEC 90				IEC 100				IEC 112			
	A	LT	Z	ØD	A	LT	Z	ØD	A	LT	Z	ØD	A	LT	Z	ØD	A	LT	Z	ØD	A	LT	Z	ØD
170003	-																							
170004	-																							
170005	917.5	276	36	140	917.5	276	36	160	917.5	296	56	200	917.5	296	56	200	917.5	306	66	250	917.5	306	66	250

PLB	IEC 132				IEC 160				IEC 180				IEC 200				IEC 225			
	A	LT	Z	ØD	A	LT	Z	ØD	A	LT	Z	ØD	A	LT	Z	ØD	A	LT	Z	ØD
170003	-				818.5	433	118	350	818.5	433	118	350	818.5	463	148	400	818.5	454	139	450
170004	-				879.5	433	118	350	879.5	433	118	350	879.5	463	148	400	-			
170005	917.5	340	100	300	917.5	358	139	350	917.5	358	139	350	-				-			

PLB	IEC ~ Kg										
	63	71	80	90	100	112	132	160	180	200	225
170003	-	-	-	-	-	-	-	1032	1032	1042	1047
170004	-	-	-	-	-	-	-	1065	1065	1075	-
170005	1033	1033	1035	1035	1036	1036	1040	1050	1050	-	-

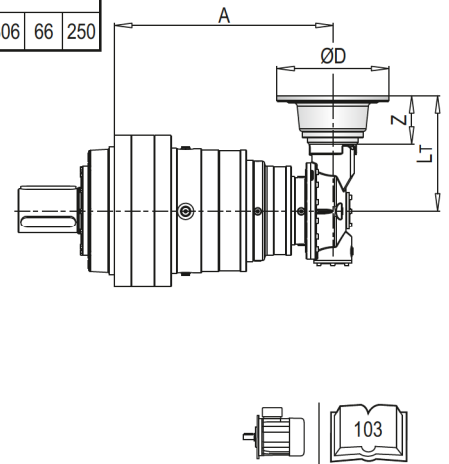

**PLB 170000 MC** - Giriş Milleri / Input Shafts / Antriebswellen / Alberi Entrata / Arbres D'entree / Ejes De Entrada

PLB	EL C 28					EL C 42					EML 42					EML 1"3/8 Z6					EM 65				
	A	LT	Z	L	Ød	A	LT	Z	L	Ød	A	LT	Z	L	Ød	A	LT	Z	L	Ød	A	LT	Z	L	Ød
170003	-																								
170004	-																								
170005	917.5	304	64	50	28	917.5	304	64	82	42	917.5	334	94	82	42	917.5	334	94	106	1"3/8	917.5	361.5	121.5	105	65

PLB	EM 1"3/8 Z6					EP 65				
	A	LT	Z	L	Ød	A	LT	Z	L	Ød
170003	818.5	436.5	121.5	105	1"3/8	818.5	468	153	105	65
170004	879.5					879.5				
170005	917.5	361.5	-							

PLB	~ Kg						
	EL C 28	EL C 42	EML 42	EML 1"3/8 Z6	EM 65	EM 1"3/8 Z6	EP 65
170003	-	-	-	-	1027	1027	1036
170004	-	-	-	-	1060	1060	1069
170005	1033.5	1034	1037	1037	1045	1045	1054

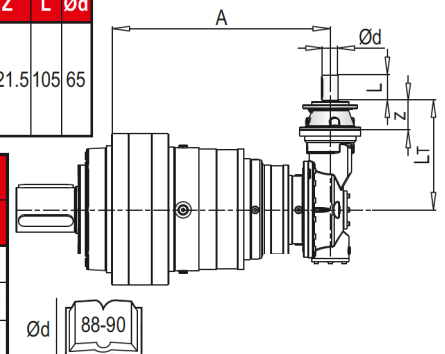

# PL/PLB 170000 F

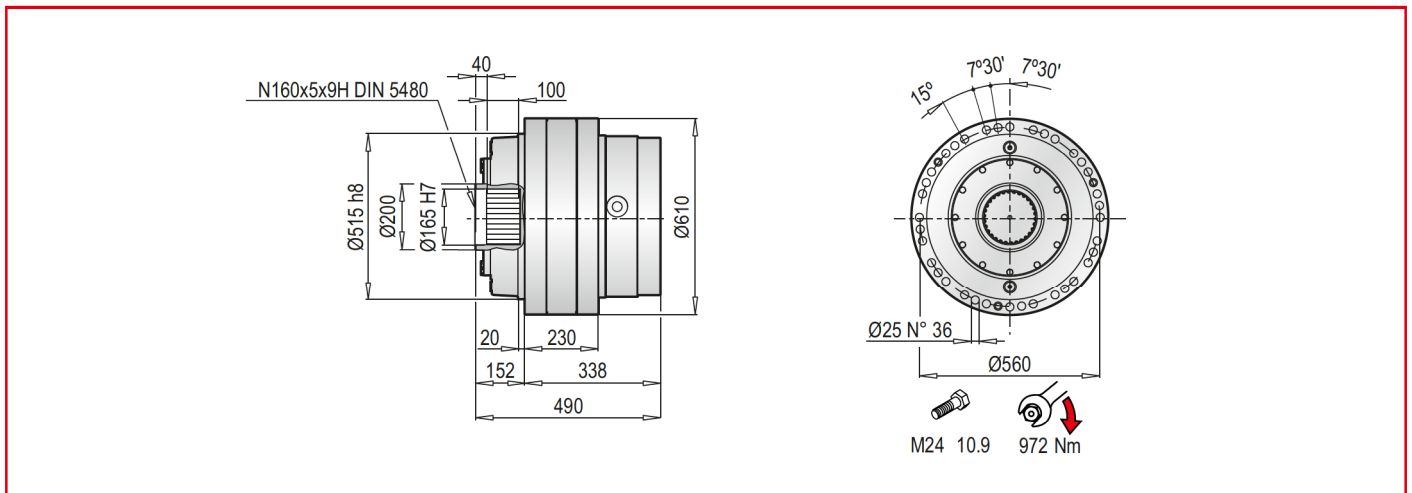

**PL 170000 F** - Elektrik Motor Adaptörleri (IEC) / Electric Motor Couplings (IEC) /Anbauvorrichtung Für Elektromotore (IEC) / Predisposizioni Per Motori Elettrici (IEC) / Adaptations Pour Moteurs Electriques (IEC) /Acoplamientos Para Motores Eléctricos (IEC)

PL	IEC 63			IEC 71			IEC 80			IEC 90			IEC 100			IEC 112			IEC 132		
	L <sub>T</sub>	Z	ØD	L <sub>T</sub>	Z	ØD	L <sub>T</sub>	Z	ØD	L <sub>T</sub>	Z	ØD	L <sub>T</sub>	Z	ØD	L <sub>T</sub>	Z	ØD	L <sub>T</sub>	Z	ØD
170001	-	-	-	-	-	-	-	-	-	-	-	-	-	-	-	-	-	-	-	-	-
170002	-	-	-	-	-	-	-	-	-	-	-	-	-	-	-	-	-	-	-	-	-
170003	-	-	-	-	-	-	-	-	-	-	-	-	-	-	-	-	-	-	-	-	-
170004	852	36	140	852	36	160	876	56	200	876	56	200	886	66	250	886	66	250	916	100	300
170005	913	36	140	913	36	160	933	56	200	933	56	200	943	66	250	943	66	250	977	100	300

PL	IEC 160			IEC 180			IEC 200			IEC 225			IEC 250			IEC 280		
	L <sub>T</sub>	Z	ØD	L <sub>T</sub>	Z	ØD	L <sub>T</sub>	Z	ØD	L <sub>T</sub>	Z	ØD	L <sub>T</sub>	Z	ØD	L <sub>T</sub>	Z	ØD
170001	-	150	-	-	150	-	-	150	400	-	139	450	-	139	550	-	139	550
170002	787.5	118	350	787.5	118	350	787.5	148	400	776.5	139	450	776.5	139	550	-	-	-
170003	862.5	118	350	862.5	118	350	892.5	148	400	883.5	139	450	-	-	-	-	-	-
170004	955	139	350	955	139	350	-	-	-	-	-	-	-	-	-	-	-	-
170005	1016	139	350	1016	139	350	-	-	-	-	-	-	-	-	-	-	-	-

PL	IEC ~ Kg												
	63	71	80	90	100	112	132	160	180	200	225	250	280
170001	-	-	-	-	-	-	-	705	705	710	716	728	740
170002	-	-	-	-	-	-	-	937	937	942	948	960	-
170003	-	-	-	-	-	-	-	957	957	967	972	-	-
170004	955	955	957	957	958	958	962	972	972	-	-	-	-
170005	965	965	967	967	968	968	972	982	982	-	-	-	-

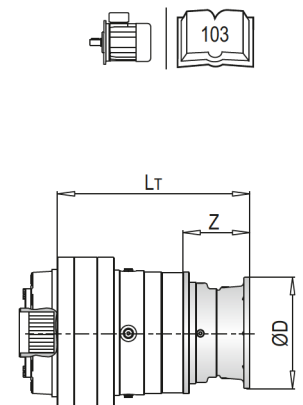

**PL 170000 F** - Giriş Milleri / Input Shafts / Antriebswellen / Alberi Entrata / Arbres D'entree / Ejes De Entrada

PL	EL C 28				EL C 42				EML 42				EML 1"3/8 Z6				EM 65				EM 1"3/8 Z6			
	L <sub>T</sub>	Z	L	Ød	L <sub>T</sub>	Z	L	Ød	L <sub>T</sub>	Z	L	Ød	L <sub>T</sub>	Z	L	Ød	L <sub>T</sub>	Z	L	Ød	L <sub>T</sub>	Z	L	Ød
170002	-	-	-	-	-	-	-	-	-	-	-	-	-	-	-	-	-	-	-	-	-	-	-	-
170003	-	-	-	-	-	-	-	-	-	-	-	-	-	-	-	-	856	121.5	105	65	866	121.5	105	1"3/8
170004	880	64	50	28	880	64	82	42	910	94	82	42	910	94	106	1"3/8	937.5	121.5	105	65	937.5	121.5	105	1"3/8
170005	941	64	50	28	941	64	82	42	971	94	82	42	971	94	106	1"3/8	-	-	-	-	-	-	-	-

PL	EP 65				ET 90				PL	~ Kg							
	L <sub>T</sub>	Z	L	Ød	L <sub>T</sub>	Z	L	Ød		EL C 28	EL C 42	EML 42	EML 1"3/8 Z6	EM 65	EM 1"3/8 Z6	EP 65	ET 90
170002	-	-	-	-	809	171.5	170	90	170002	-	-	-	-	-	-	-	940
170003	897.5	153	105	65	916	171.5	170	90	170003	-	-	-	-	952	952	961	1018
170004	969	153	105	65	-	-	-	-	170004	955.5	956	959	959	967	967	976	-
170005	-	-	-	-	-	-	-	-	170005	965.5	966	969	969	-	-	-	-

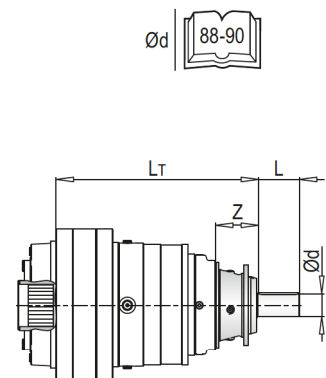



**PL 170000 F - Sonsuz Dişli Redüktör Adaptörleri (PMRV/PRV) / Worm Gearbox Adaptors (PMRV/PRV) / Anschluss Für Schneckengetriebe (PMRV/PRV) / Predisposizioni Per Riduttori A Vite Senza Fine (PMRV/PRV) / Adaptation Pour Reducteurs A Vis Sans Fin (PMRV/PRV) / Acoplamiento Para Reductores De Tornillo Sin Fin (PMRV/PRV)**

PL	PMRV/PRV 050					PMRV/PRV 063					PMRV/PRV 075				
	Lm	l	h	Ma	G	Lm	l	h	Ma	G	Lm	l	h	Ma	G
170003	-					-					-				
170004	937.5	50	110	60	80	947	63	113	72	95	926	75	161	86	112.5
170005	998.5					1008					987				

PL	PMRV/PRV 090					PMRV/PRV 110					PMRV/PRV 130				
	Lm	l	h	Ma	G	Lm	l	h	Ma	G	Lm	l	h	Ma	G
170003	-					878.5	110	237.5	127.5	160	884	130	277.5	147.5	180
170004	936	90	193	103	129.5	950					955.5				
170005	997					-					-				

PL	PMRV/PRV 150				
	Lm	l	h	Ma	G
170003	900.5	150	320	170	210
170004	972				
170005	-				

PL	PMRV/PRV ~ Kg						
	050	063	075	090	110	130	150
170003	-	-	-	-	1016	1033	1061
170004	993	996.5	999	1004	1031	1048	1076
170005	1003	1006.5	1009	1014	-	-	-

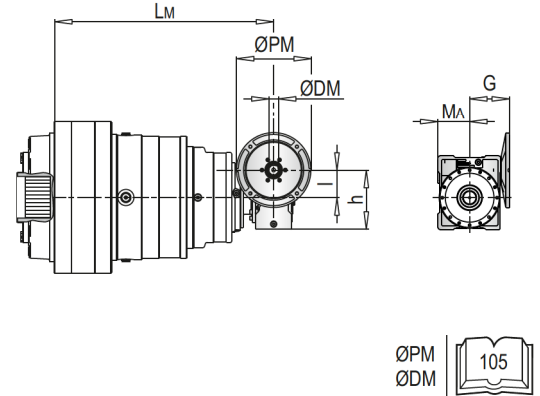

**PLB 170000 F - Elektrik Motor Adaptörleri (IEC) / Electric Motor Couplings (IEC) / Anbauvorrichtung Für Elektromotore (IEC) / Predisposizioni Per Motori Elettrici (IEC) / Adaptations Pour Moteurs Electriques (IEC) / Acoplamientos Para Motores Eléctricos (IEC)**

PLB	IEC 63				IEC 71				IEC 80				IEC 90				IEC 100				IEC 112			
	A	Lt	Z	ØD	A	Lt	Z	ØD	A	Lt	Z	ØD	A	Lt	Z	ØD	A	Lt	Z	ØD	A	Lt	Z	ØD
170003	-				-				-				-				-							
170004	-				-				-				-				-							
170005	917.5	276	36	140	917.5	276	36	160	917.5	296	56	200	917.5	296	56	200	917.5	306	66	250	917.5	306	66	250

PLB	IEC 132				IEC 160				IEC 180				IEC 200				IEC 225			
	A	Lt	Z	ØD	A	Lt	Z	ØD	A	Lt	Z	ØD	A	Lt	Z	ØD	A	Lt	Z	ØD
170003	-				818.5	433	118	350	818.5	433	118	350	818.5	463	148	400	818.5	454	139	450
170004	-				879.5				879.5				879.5				-	-	-	-
170005	917.5	340	100	300	917.5	358	139		917.5	358	139		-	-	-	-	-	-		

PLB	IEC ~ Kg										
	63	71	80	90	100	112	132	160	180	200	225
170003	-	-	-	-	-	-	-	997	997	1007	1064
170004	-	-	-	-	-	-	-	1030	1030	1040	-
170005	998	998	1000	1000	1001	1001	1005	1015	1015	-	-

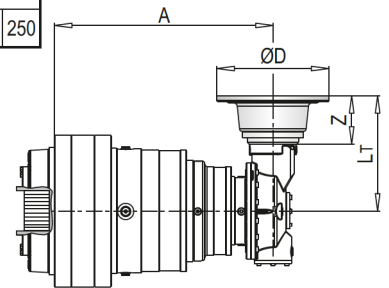

**PLB 170000 F - Giriş Milleri / Input Shafts / Antriebswellen / Alberi Entrata / Arbres D'entree / Ejes De Entrada**

PLB	EL C 28					EL C 42					EML 42					EML 1"3/8 Z6					EM 65								
	A	Lt	Z	L	Ød	A	Lt	Z	L	Ød	A	Lt	Z	L	Ød	A	Lt	Z	L	Ød	A	Lt	Z	L	Ød				
170003	-					-					-					-					818.5	436.5	121.5	105	65				
170004	-					-					-					-					879.5								
170005	917.5	304	64	50	28	917.5	304	64	82	42	917.5	334	94	82	42	917.5	334	94	106	1"3/8	917.5	361.5							

PLB	EM 1"3/8 Z6					EP 65				
	A	Lt	Z	L	Ød	A	Lt	Z	L	Ød
170003	818.5	436.5	121.5	105	65	818.5	468	153	105	65
170004	879.5					879.5				
170005	917.5	361.5				917.5	393			

PLB	~ Kg						
	EL C 28	EL C 42	EML 42	EML 1"3/8 Z6	EM 65	EM 1"3/8 Z6	EP 65
170003	-	-	-	-	992	992	1001
170004	-	-	-	-	1025	1025	1034
170005	980.5	981	984	984	1010	1010	1019

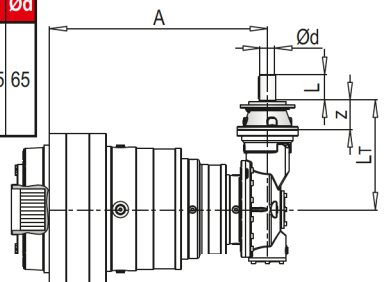

**PL/PLB 170000 FS**

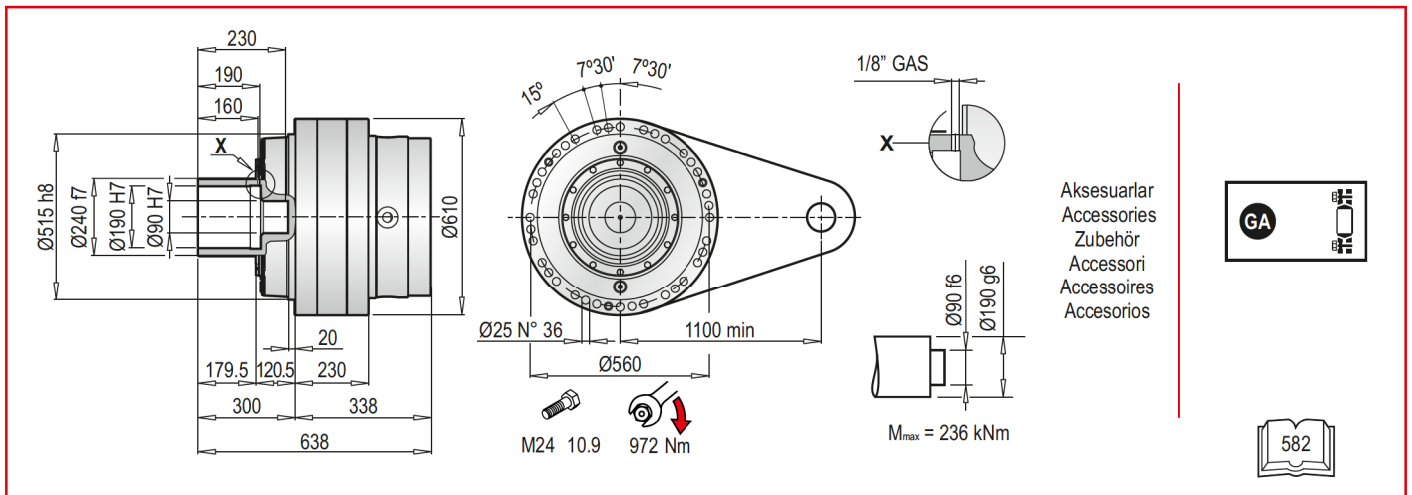

**PL 170000 FS - Elektrik Motor Adaptörleri (IEC) / Electric Motor Couplings (IEC) / Anbauvorrichtung Für Elektromotore (IEC) / Predisposizioni Per Motori Elettrici (IEC) / Adaptations Pour Moteurs Electriques (IEC) / Acoplamientos Para Motores Eléctricos (IEC)**

PL	IEC 63			IEC 71			IEC 80			IEC 90			IEC 100			IEC 112			IEC 132		
	Lt	Z	ØD	Lt	Z	ØD	Lt	Z	ØD	Lt	Z	ØD	Lt	Z	ØD	Lt	Z	ØD	Lt	Z	ØD
170001	-	-	-	-	-	-	-	-	-	-	-	-	-	-	-	-	-	-	-	-	-
170002	-	-	-	-	-	-	-	-	-	-	-	-	-	-	-	-	-	-	-	-	-
170003	-	-	-	-	-	-	-	-	-	-	-	-	-	-	-	-	-	-	-	-	-
170004	852	36	140	852	36	160	876	56	200	876	56	200	886	66	250	886	66	250	916	100	300
170005	913	-	-	913	-	-	933	-	-	933	-	-	943	-	-	943	-	-	977	-	-

PL	IEC 160			IEC 180			IEC 200			IEC 225			IEC 250			IEC 280		
	Lt	Z	ØD	Lt	Z	ØD	Lt	Z	ØD	Lt	Z	ØD	Lt	Z	ØD	Lt	Z	ØD
170001	-	150	-	-	150	-	-	150	400	-	139	450	-	139	550	-	139	550
170002	787.5	-	-	787.5	-	-	787.5	-	-	776.5	-	-	776.5	-	-	-	-	-
170003	862.5	118	350	862.5	118	350	892.5	148	-	883.5	-	-	-	-	-	-	-	-
170004	955	-	-	955	-	-	-	-	-	-	-	-	-	-	-	-	-	-
170005	1016	139	-	1016	139	-	-	-	-	-	-	-	-	-	-	-	-	-

PL	IEC ~ Kg												
	63	71	80	90	100	112	132	160	180	200	225	250	280
170001	-	-	-	-	-	-	-	722	722	727	733	745	757
170002	-	-	-	-	-	-	-	964	964	969	975	987	-
170003	-	-	-	-	-	-	-	984	984	994	999	-	-
170004	982	982	984	984	985	985	989	999	999	1009	1014	-	-
170005	992	992	994	994	995	995	999	1009	1009	1019	-	-	-

**PL 170000 FS - Giriş Milleri / Input Shafts / Antriebswellen / Alberi Entrata / Arbres D'entree / Ejes De Entrada**

PL	EL C 28				EL C 42				EML 42				EML 1"3/8 Z6				EM 65				EM 1"3/8 Z6			
	Lt	Z	L	Ød	Lt	Z	L	Ød	Lt	Z	L	Ød	Lt	Z	L	Ød	Lt	Z	L	Ød	Lt	Z	L	Ød
170002	-	-	-	-	-	-	-	-	-	-	-	-	-	-	-	-	-	-	-	-	-	-	-	-
170003	-	-	-	-	-	-	-	-	-	-	-	-	-	-	-	-	856	121.5	105	65	866	121.5	105	1"3/8
170004	880	64	50	28	880	64	82	42	910	94	82	42	910	94	106	1"3/8	937.5	-	-	-	937.5	-	-	-
170005	941	-	-	-	941	-	-	-	971	-	-	-	971	-	-	-	-	-	-	-	-	-	-	-

PL	EP 65				ET 90				PL	~ Kg							
	Lt	Z	L	Ød	Lt	Z	L	Ød		EL C 28	EL C 42	EML 42	EML 1"3/8 Z6	EM 65	EM 1"3/8 Z6	EP 65	ET 90
170002	-	-	-	-	809	171.5	170	90	170002	-	-	-	-	-	-	-	967
170003	897.5	153	105	65	916	-	-	-	170003	-	-	-	-	979	979	988	1045
170004	969	-	-	-	-	-	-	-	170004	982.5	983	986	986	994	994	1003	-
170005	-	-	-	-	-	-	-	-	170005	992.5	993	996	996	-	-	-	-



Aksesuarlar  
Accessories  
Zubehör  
Accessori  
Accesoires  
Accesorios

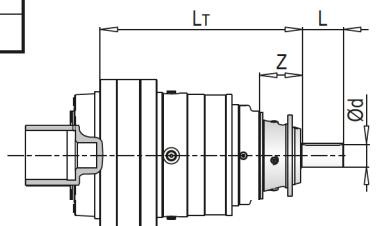
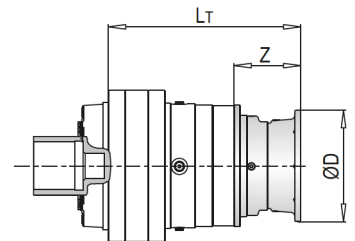

**PL 170000 FS** - Sonsuz Dişli Redüktör Adaptörleri (PMRV/PRV) / Worm Gearbox Adaptors (PMRV/PRV) / Anschluss Für Schneckengetriebe (PMRV/PRV) / Predisposizioni Per Riduttori A Vite Senza Fine (PMRV/PRV) / Adaptation Pour Reducteurs A Vis Sans Fin (PMRV/PRV) / Acoplamiento Para Reductores De Tornillo Sin Fin (PMRV/PRV)

PL	PMRV/PRV 050					PMRV/PRV 063					PMRV/PRV 075				
	Lm	l	h	Ma	G	Lm	l	h	Ma	G	Lm	l	h	Ma	G
170003	-					-					-				
170004	937.5	50	110	60	80	947	63	113	72	95	926	75	161	86	112.5
170005	998.5					1008					987				

PL	PMRV/PRV 090					PMRV/PRV 110					PMRV/PRV 130				
	Lm	l	h	Ma	G	Lm	l	h	Ma	G	Lm	l	h	Ma	G
170003	-					878.5	110	237.5	127.5	160	884	130	277.5	147.5	180
170004	936	90	193	103	129.5	950					955.5				
170005	997					-					-				

PL	PMRV/PRV 150				
	Lm	l	h	Ma	G
170003	900.5	150	320	170	210
170004	972				
170005	-				

PL	PMRV/PRV ~ Kg						
	050	063	075	090	110	130	150
170003	-	-	-	-	968	1025	1061
170004	985	988.5	991	996	1023	1040	1076
170005	995	998.5	1001	1006	-	-	-

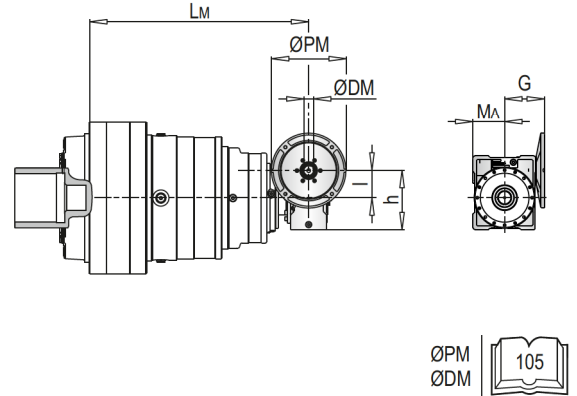

**PLB 170000 FS** - Elektrik Motor Adaptörleri (IEC) / Electric Motor Couplings (IEC) / Anbauvorrichtung Für Elektromotore (IEC) / Predisposizioni Per Motori Elettrici (IEC) / Adaptations Pour Moteurs Electriques (IEC) / Acoplamientos Para Motores Eléctricos (IEC)

PLB	IEC 63				IEC 71				IEC 80				IEC 90				IEC 100				IEC 112			
	A	LT	Z	ØD	A	LT	Z	ØD	A	LT	Z	ØD	A	LT	Z	ØD	A	LT	Z	ØD	A	LT	Z	ØD
170003	-				-				-				-				-							
170004	-				-				-				-				-							
170005	917.5	276	36	140	917.5	276	36	160	917.5	296	56	200	917.5	296	56	200	917.5	306	66	250	917.5	306	66	250

PLB	IEC 132				IEC 160				IEC 180				IEC 200				IEC 225			
	A	LT	Z	ØD	A	LT	Z	ØD	A	LT	Z	ØD	A	LT	Z	ØD	A	LT	Z	ØD
170003	-				818.5	433	118	350	818.5	433	118	350	818.5	463	148	400	818.5	454	139	450
170004	-				879.5				879.5				879.5							
170005	917.5	340	100	300	917.5	358	139		917.5	358	139									

PLB	IEC ~ Kg										
	63	71	80	90	100	112	132	160	180	200	225
170003	-	-	-	-	-	-	-	1024	1024	1034	1039
170004	-	-	-	-	-	-	-	1057	1057	1067	-
170005	1025	1025	1027	1027	1028	1028	1032	1042	1042	-	-

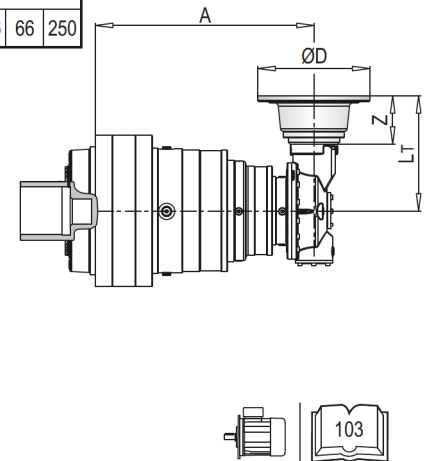

**PLB 170000 FS** - Giriş Milleri / Input Shafts / Antriebswellen / Alberi Entrata / Arbres D'entree / Ejes De Entrada

PLB	EL C 28					EL C 42					EML 42					EML 1"3/8 Z6					EM 65				
	A	LT	Z	L	Ød	A	LT	Z	L	Ød	A	LT	Z	L	Ød	A	LT	Z	L	Ød	A	LT	Z	L	Ød
170003	-					-					-					-					818.5	436.5	121.5	105	65
170004	-					-					-					-					879.5				
170005	917.5	304	64	50	28	917.5	304	64	82	42	917.5	334	94	82	42	917.5	334	94	106	1"3/8	917.5	361.5			

PLB	EM 1"3/8 Z6					EP 65				
	A	LT	Z	L	Ød	A	LT	Z	L	Ød
170003	818.5	436.5	121.5	105	65	818.5	468	153	105	65
170004	879.5					879.5				
170005	917.5	361.5				917.5	393			

PLB	~ Kg						
	EL C 28	EL C 42	EML 42	EML 1"3/8 Z6	EM 65	EM 1"3/8 Z6	EP 65
170003	-	-	-	-	1019	1019	1028
170004	-	-	-	-	1052	1052	1061
170005	1025.5	1026	1029	1029	1037	1037	1046

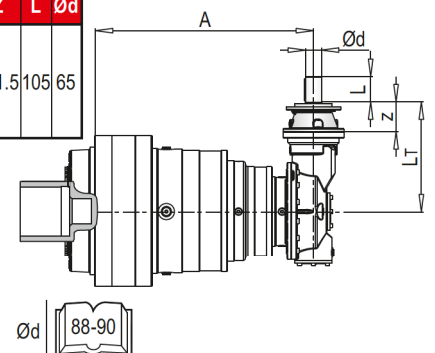

**PL/PLB 170000 Nm**

**AKSESUARLAR / ACCESSORIES / ZUBEHÖR / ACCESSORI / ACCESSOIRES / ACCESORIOS**

**BS** Spline kaplin / Splined bushing / Innenverzahnte Buchse  
Boccola scanalata / Moyeu cannelé / Casquillo ranurado

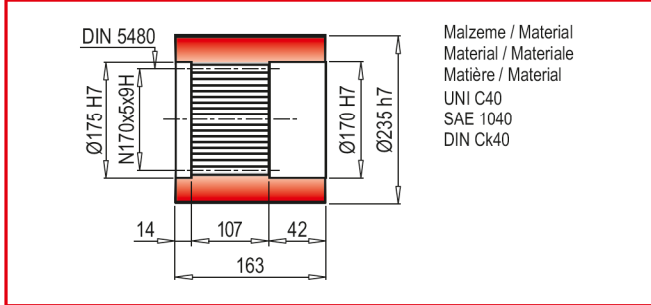

**FF** Sabitleme rondelası / Stop bottom plate / Endscheibe  
Fondello di arresto / Bouchon de fermeture / Tapón de detención

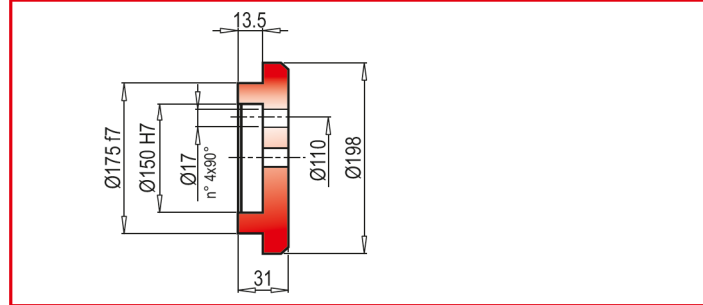

**FL** Flanş / Flange / Flansch  
Flangia / Bride / Brida

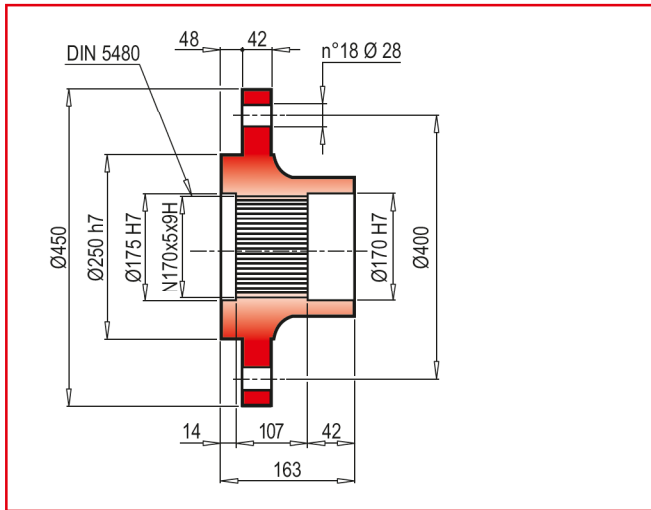

**GA** Konik sıkırma / Shrink disc / Schrumpfscheibe  
Giunto di attrito / Frette de serrage / Disco de contracción

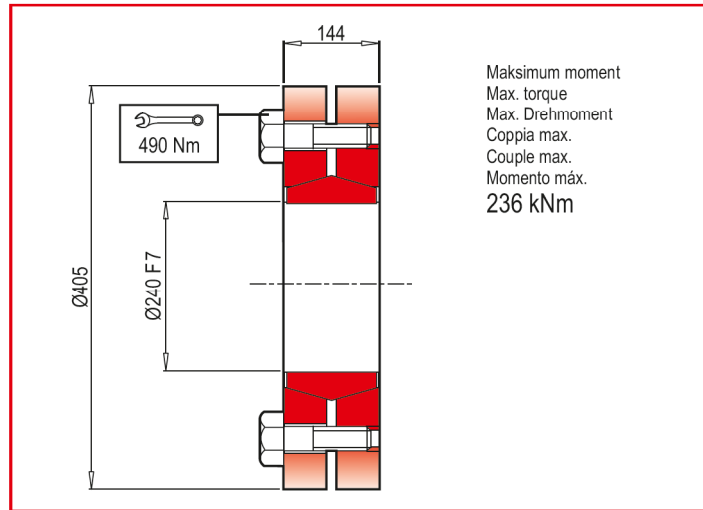

TR

**RADYAL YÜKLER (Fr)**

Aşağıdaki grafikler istenilen  $n_2xh$  değerinin elde edilmesi için gerekli olan radyal yükleri ve K faktörlerini göstermektedir.

EN

**RADIAL LOADS (Fr)**

The following curves show the radial loads and the K factors to obtain the required  $n_2xh$  value.

DE

**RADIALLAST (Fr)**

In den nachstehenden Diagrammen ist die Radiallast und der Koeffizient K dargestellt und kann mit dem gewünschten Wert  $n_2xh$  verglichen werden.

IT

**CARICHI RADIALI (Fr)**

Nei diagrammi seguenti sono riportati i carichi radiali e i coefficienti K per rapportarli al valore  $n_2xh$  desiderato.

FR

**CHARGES RADIALES (Fr)**

Dans les diagrammes suivants sont indiqués les charges radiales et les facteurs K de façon à obtenir la valeur  $n_2xh$  désirée.

ES

**CARGAS RADIALES (Fr)**

En los siguientes diagramas se indican las cargas radiales y los coeficientes K para obtener el valor requerido  $n_2xh$ .

**M**

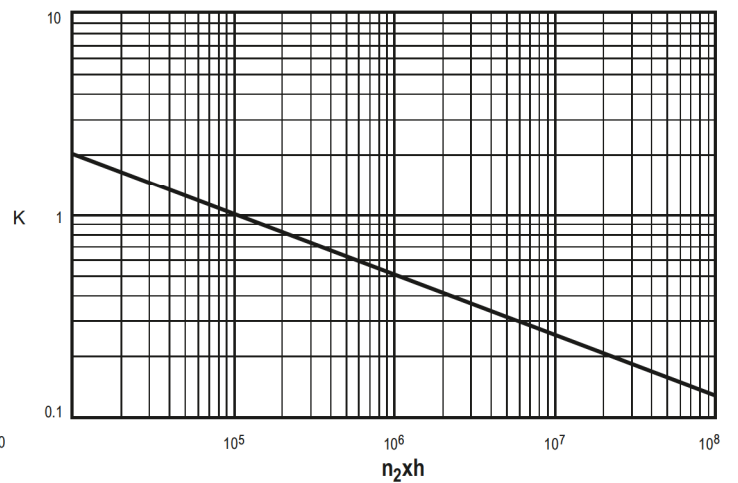
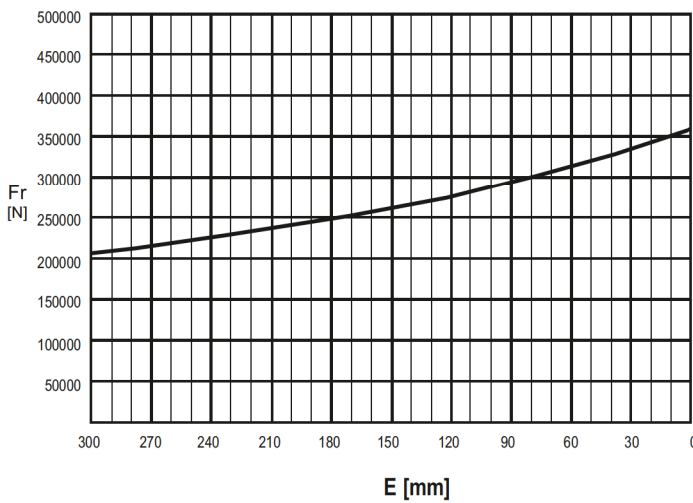

M	$n_2xh$				
	$10^5$	$10^4$	$10^6$	$10^7$	$10^8$
Fr			Fr · K		

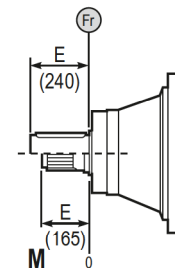

TR

**EKSENEL YÜKLER (Fa)**

Tabloda yer alan eksenel yük değerleri, çıkış tipine ve uygulamanın yük yönüne göre değişir.

EN

**AXIAL LOADS (Fa)**

The values of the axial loads in the table refer to the output versions and load direction of application.

DE

**AXIALLAST (Fa)**

Die dargestellten Werte der Axiallast basieren auf der Version und der applizierten Lastrichtung.

IT

**CARICHI ASSIALI (Fa)**

I valori dei carichi assiali indicati in tabella sono riferiti alle versioni e alla direzione di applicazione del carico.

FR

**CHARGES AXIALES (Fa)**

Les valeurs des charges axiales indiquées dans le tableau se réfèrent aux versions et à la direction d'application de la charge.

ES

**CARGAS AXIALES (Fa)**

Los valores de las cargas axiales indicados en la tabla se refieren a las versiones y a la dirección de aplicación de la carga.

Fa	M	←
	75000	
[N]	65250	→

